

[Break out of a frame](#)

[A Poem in Defense of Lunars](#)

Recent Additions [here](#) - Land
and Sea Collection

Message from the webmistress
concerning email and other notes -
also, please order from Amazon
here to keep this site alive!

[APRIL 2004](#)

Celestial Navigation Net



C chiamavi 'l cielo e 'ntorno vi si gira,
mostrandovi le sue bellezze etterne*

Why Celestial Navigation?

History

Navigational Astronomy

The Theory

The Practice

CelNav in the Classroom

Navigational Instruments

The Vikings

Wayfinding

Quotations

Resources

Dante

Other Links of Interest

Schools

Contact

Webmistress

Welcome to the Celestial Navigation Net! Celestial Navigation is the art and science of finding your way by the sun, moon, stars, and planets, and, in one form or another, is one of the oldest practices in human history. This webpage is an attempt to bring together all of the best Celestial Navigation resources on the internet, with pointers to other resources as well. Find out [why](#) we should study Celestial navigation in the age of GPS; get an introduction to Celestial Navigation's [history](#), then take a look at the [navigational astronomy](#) page as a background for the [theory](#) and [practice](#); teachers, discover how celestial navigation can enliven the [classroom](#), whether your field is earth science, astronomy, math, history, or literature, with special links about [Vikings](#); learn about [navigational instruments](#), including sextants, astrolabes, nocturnals, and planispheres; learn about nonwestern, noninstrument Polynesian starpaths and [Wayfinding](#); read [quotations](#) about navigation; check out some [schools](#); or just go directly to the list of [resources](#) which lists the sources from the other pages. Other links of interest are [here](#).

**The heavens call to you and circle about you, displaying to you their eternal splendors...." Dante, Purgatorio, Canto XIV*

**[Marion-Bermuda Race](#)
[offers Celestial Certificate](#)**

All original material copyright 2000 and 2001. Every effort has been made to use only pictures in the public domain or created by webmistress. ([why "webmistress?"](#)) If you are the copyright owner of a picture or quotation inadvertently used without attribution or permission, [contact me](#). Please write with links and corrections as well.

A Poem in Defense of Lunars

This poem was presented to me by Captain Ted Spurling Sr. of Little Cranberry Island, Maine, the navigator who most inspires me and to whom this site is dedicated.

He wrote, "This nautical poem by Mr. E. Plumstead, an ardent defender of lunar observations, was taken from a popular old English navigation book titled Wrinkles by S.T.S. Lecky, master mariner, it being the 20th edition... This book was given to me nearly fifty years ago by a cousin, Captain Tom Kelley, of West Tremont, on Mount Desert Island, Maine."

There was a time when Parallax and dear old Mrs. Moon
Were understood by seamen, and esteemed a precious boon.
Then Wrinkles came; Edition Nine burst forth mid jubilation,
Waxed fat and kicked, and then ensued the following conversation:

"Pack up! Clear out!" said Wrinkles, "Take notice now, and mind,
Both Parallax and you to Coventry we've consigned."

"Who's We?" retorted Mrs. Moon, "I've never heard such fudge;
Are you the We? Have I no friends? Are you the only judge?"

"You've hit it off," said Wrinkles, "I am the We, far famed:
You've lost your ancient following, of your conduct they're ashamed,
Except a few 'Old Timers,' who from sundry dark recesses
Sing your praises in the papers, have no names, give no addresses."

"That's rather neat," replied the Moon, "But will you have the kindness
Just to state the cause of this revolt, and why this modern blindness
To the virtues that I still possess? Explain the situation.
What has blighted all my virtues? Who has spoiled my reputation?"

"Where have you been? What have you learned?" said Wrinkles, "Don't you know
What happened here - it must be near a century ago?
You've heard of Sextant, Compass, Log, Mercurial Barometer;
Tremble! a goddess has been born. We've christened her Chronometer.

"Behold my love, is she not fair? so strong, so plump, so pliable."

"All Tommy Rot," replied the Moon, "I'll bet she's not reliable."

"Alas!" said Wrinkles, "I know that; for has it not been noted,

To her most eccentric conduct my best chapter's been devoted?

"Had you but read what I have said on her merits and demerits
In Chapter Four, not for one hour would you maintain your spirits;
Could I but show you Wrinkles your appearance would cease,
You'd for ever hide your 'bloomin' cheek,' for ever hold your peace."

"Of Wrinkles, sir," replied the Moon, "we've several copies here;
But the chapter headed Lunars is the one we hold most dear.
With equal care we've read them both; compared our notes and reckoned.
No mortal who believed the first could understand the second.

"T is just about twelve months ago, I said to some inquirers,
'You had no power to banish me, I still had some admirers.'
Adieu! dear boy. I'm off. Good night. To Coventry? No! Never!
Let 'Wrinkles' come, Chronometers go, but I go on for ever."

• [Home](#) • [Why Celestial Navigation?](#) • [History](#) • [Navigational Astronomy](#) • [The Theory](#) • [The Practice](#) • [Celnav in the Classroom](#) • [Vikings](#) • [Navigational Instruments](#) • [Wayfinding](#) • [Schools](#) • [Quotations](#) • [Resources](#) • [Dante](#) • [Other Links](#) • [Webmistress](#) •

Recent Additions

NEW!!! The "Land and Sea Collection" is

the source for fine quality ship and aircraft models, vintage ships clocks, polished brass nautica, shipbuilders plates, marine antiques, and is the largest seller of used and pre-owned marine sextants on the internet.

I checked out this site and it was awesome! See it at <http://www.landandseacollection.com/>

Starpath School of Navigation has a new celestial navigation course that you can do online. This is the same course that taught me everything I know, but with updated materials. I have received the materials and they are even better than the ones I used.



Click on the link for the Starpath home page.



**New book on Viking Navigation by
Leif K. Karlsen: [Secrets of the Viking Navigators](#)**

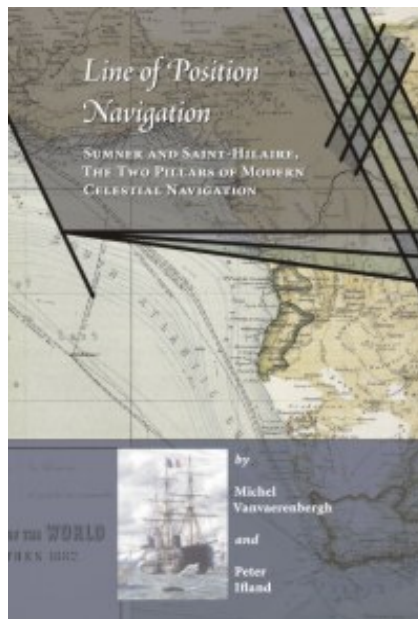

NEW BOOK by Peter Ifland and Michel Vanvaerenbergh: [Line of Position Navigation: Sumner and Saint-Hilaire, The Two Pillars of Modern Celestial Navigation](#)

[New link for Palm Pilot Celnav Program](#)

[Celestaire's Cardboard Sextant Kit](#)

Omar Reis's [Interactive Sextant](#) on the "[Instruments](#)" Page; also his "[Build Your Own Sextant](#)" on the "[Classroom](#)" Page.

Sight Worksheets on [Reader page](#)

[AstroNav PC and Compact Data](#) and other SOFTWARE is at the bottom of the "[Practice](#)" page.

[Sail the Sounds Celestial Navigation Course](#) on "[Schools](#)" page.

[Bowditch's American Practical Navigator - Now with Tables!!](#) On "[Practice](#)" and "[Classroom](#)" pages.

[David Thompson and Land Navigation](#) (19th century America) on "[Classroom](#)" Page.

[Pocket Stars PC Program](#) - Integrated Star Chart, Ephemeris, and Celestial Navigation Software for the Pocket PC

[Bowditch Initiative Website](#) - Nathaniel Bowditch on "[Classroom](#)" page.

[Nova's Shockwave Game on Finding Your Latitude](#) on "[Classroom](#)" Page

[Navigating Around the World By Observing the Sun](#) on "[Classroom](#)" page

[How A Sextant Works](#) and [Navigating by Sextant](#) on the "[Instruments](#)" page

[How Columbus and Apollo Astronauts Navigated](#) on "[Classroom](#)" page

[Celestial Navigation for Dummies](#) on "[Practice](#)"

[ASNAv and Delta Win](#) on "[Practice](#)"

[The Abaco Wild Horse Fund](#) on "[Other Links](#)" page

["The Sun in the Church: Cathedrals as Solar Observatories"](#) on "[Other Links](#)"

Helmer Aslaksen's page on [Cultural Astronomy](#) - See "[Other Links](#)" and also Astronomy page

for comment on the java applets Helmer has available.

[Aboriginal \(Native American\) Astronomy](#) - See "[Classroom](#)" page

[Ed Falk's Sample Page from the Silicon Sea Series](#) (say that three times fast!) - See "[Practice](#)" Page

[African Star Lore](#) - "[Classroom](#)" page

[Longitude at Sea, from the Galileo Project](#) - "[Classroom](#)" page

[Astronomy without a Telescope](#) - "[Astronomy](#)" and "[Classroom](#)"

[David Thompson and Land Navigation](#) - "[Classroom](#)"

[Civil and Nautical Twilight; Sunrise Set, Moonrise and Set](#)

[Scientific Instruments of Medieval and Renaissance Europe](#) - "[Instruments](#)" page - "[Instruments](#)" page

Peter Ifland's lecture, [THE HISTORY OF THE SEXTANT](#) - "[Instruments](#)"

[Celestial Themes in Art and Architecture](#) at Dartmouth - "[Dante](#)" page

-
- [Home](#) • [Why Celestial Navigation?](#) • [History](#) • [Navigational Astronomy](#) • [The Theory](#) • [The Practice](#) • [Celnav in the Classroom](#) • [Vikings](#) • [Navigational Instruments](#) • [Wayfinding](#) • [Schools](#) • [Quotations](#) • [Resources](#) • [Dante](#) • [Other Links](#) • [Webmistress](#) •

A Message from the Webmistress

FIRST: I have changed my email address to webmistress2 at celestialnavigation.net. Put in the "at" symbol for the word "at." obviously! People have been getting emails with viruses attached that APPEAR to be from me, but I am actually the victim of a return address hijack. This kind of virus goes on to someone's system, then sends emails that appear to be FROM someone who is in their address book. So someone out there with the original webmistress address needs to update their virus software ASAP!

SECOND: It is with great sorrow that I report that Captain Ted Spurling Sr., to whom this site is dedicated and without whom it would not have existed, died earlier this year. It is he who gave me the poem in defense of lunars, "Wrinkles." Captain Spurling was the kindest and most interesting man on the Maine island I call my second home, with many, many years of experience in celestial navigation. I spent hours with him in his home and many more sitting on the dock or by the museum, just talking. He will be greatly, greatly missed.

THIRD: The mystery of Marvin Creamer has been solved! A kind reader sent me an Ocean Navigator back issue with a whole story. As soon as I get a chance I will fill you in!

Now, PLEASE READ BELOW!

* * * * *

As you all know, this is an educational, nonprofit, noncommercial site - a labor of love. I intend to keep it that way. However, it has come to this: I have to do SOMETHING to pay for the upkeep! All along, the books and videos on this site have been linked to places you could buy them from. With Amazon, I get a teeny-tiny percentage of the book sales (so far, not enough to keep a dust mite in dust!), but your price isn't increased one penny by clicking through my site.

I have decided to add some general Amazon links, like the one below, because if more books and videos are bought through my site, I will get MORE pennies to help pay for it!

I apologize profusely for the appearance of "advertising" but it beats begging people to send me checks!

So please, if you are going to buy ANYTHING from Amazon this holiday season or any other time, please click through my site! Besides books and videos, they sell all

kinds of things - toys, software, etc., and again, anything you buy helps me and doesn't add a cent to your cost!

TRY THE LINK BELOW! Put in "sailing" or "navigation" or whatever interests you and see what comes up!

Thank you!

Search by keywords:

The logo for Amazon.com, featuring the word "amazon.com" in white lowercase letters on a black rectangular background. A yellow curved arrow is positioned below the "a" and "z", pointing from the "a" to the "z".

• [Home](#) • [Why Celestial Navigation?](#) • [History](#) • [Navigational Astronomy](#) • [The Theory](#) • [The Practice](#) • [Celnav in the Classroom](#) • [Vikings](#) • [Navigational Instruments](#) • [Wayfinding](#) • [Schools](#) • [Quotations](#) • [Resources](#) • [Dante](#) • [Other Links](#) • [Webmistress](#) •

Why Celestial Navigation?

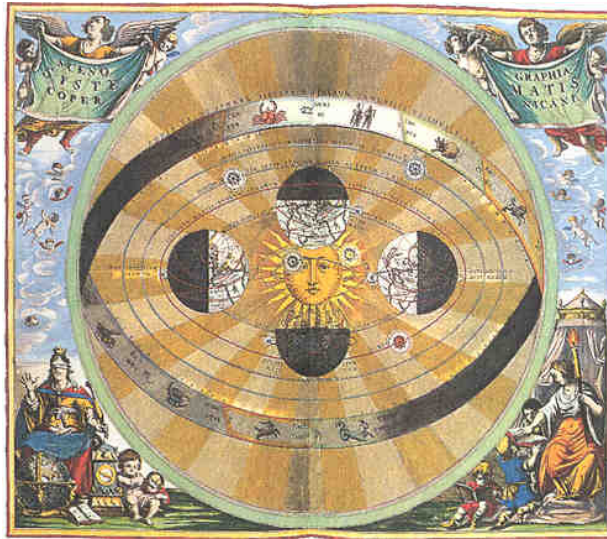

Celestial Navigation is the art and science of navigating by the stars, sun, moon, and planets, and is one of the oldest of human arts. With the rise of radio and electronic means of finding location - especially with the increasingly popular GPS, based on satellite transmissions that can tell us our latitude and longitude within feet - knowledge of celestial navigation has experienced a precipitous decline. So why should anyone study it? Your webmistress believes that if you have to ask, well.... and anyway, as that great sage Bob Weir once said, "You ain't gonna learn what you don't want to know." But if you want reasons, here are a few:

- Understanding navigation; emergency and back-up
- Tradition
- Fun
- Perspective on life
- Beautiful!

Understanding Navigation

I feel the same way about navigation as I feel about computer use. People who came up to computers and the Web through DOS or Unix, and the earlier form of the Internet, or those who through experience or trial and error have learned just about everything that needs to be done on their computers, can trouble-shoot problems a dozen different ways. Those who can only point and click, or follow cookbook instructions exactly one way, are at the mercy of the people on the other end of the computer help lines. I have met people who use only GPS and would be totally lost without it. I have nothing against GPS and would not go offshore without it, but it could be a problem for emergencies - electronics

go out, batteries die, things get wet, etc. - and if you are a big reader of sea and sailing stories, you know people's lives have been saved by their knowledge of celestial navigation. But those kinds of emergencies are rare, and a better argument might be that some knowledge of celestial navigation makes you a better sailor, because you understand what's under the surface and can solve problems more than one way.

Tradition

Your webmistress spends as much of the summer as she can on a little Maine island (don't ask, I'm not telling) where life is really the way it should be. People become their true selves once more, and the reason is community in the fullest, truest sense of the word. Part of being a community is being interdependent and part of that is being self-reliant. This isn't a paradox; people self-reliant in different ways can give their gifts back to the community. Now, I am not saying that anyone there wants or needs celestial navigation, but there is a real respect for traditional arts, crafts, and techniques. There are still men (I'm not being sexist, but they are mostly men) on the island who remember when celestial navigation was all there was, and did it in the Navy and Merchant Marine, and there is still interest and respect for an art that calls upon us to regard the heavens with intimate eyes rather than passing glances.

Many traditional arts – weaving, 19th century photo techniques, pottery, etc. - are still practiced, and there are thousands of resources available for them. But celestial navigation - one of the oldest of the traditional arts - is considered abstruse and outdated, like a manual typewriter. We'll never return to the time when the Captain was considered to be the high priest of a ship, with near-mystical powers and mysterious instruments for ascertaining a ship's location (this high level of closely-guarded skill and education was undoubtedly a factor in keeping mutinies down!), but it would be a tremendous loss to have this art die out.

Fun

OK, we all find our fun in different places, but to my mind solving the navigation problems in the back of [Ocean Navigator](#) magazine is a lot more fun and a lot more satisfying than a lot of other past-times (but then I'm weird. I admit to getting a kick out of certain really elegant chess games, and while taking a grad course in Philosophy of Mathematics, I remember the day I finally understood Godel's Proof to be a rollicking good time. Your webmistress realizes she can't be out sailing ALL the time). Plus it got me reading about all kinds of things, from star-lore to the history of calendars and time-keeping to ancient Greek and Egyptian math, astronomy, and architecture - and paying closer attention to the literature I always loved. It's the kind of passion that opens you up to all kinds of miracles and wonders of the natural world, from which so many of us have become alienated, and our shared past.

Perspective on Life

It's hard to worry about what Russian writer Osip Mandelstam called "the fleas of life" when you look up at the night sky. Few things make me feel, about some petty problem, or even some large ones, "this too shall pass," as much as considering the sky. Some people think God's answer to Job's suffering at the end of the Book of Job in the Hebrew Scriptures isn't much of an answer - considering the Pleiades isn't exactly what we were looking for - but you don't know until you've tried meditating on the stars. (Theologians and others, you don't need to email me on this - I already know there is much more to God's answer).

This is going to seem a stretch to some, but to me celestial navigation is not only an end, a tool, but something that in the Middle Ages they called a sign. It both is what it is, and points beyond itself. The [wayfinders](#) of the Pacific Islands understood this. I don't think it merely provides metaphors for life; navigation IS our life. It's what we have to do, in every area: we have to find ourselves physically, orient ourselves mentally and emotionally, and try to find a star to steer by spiritually, if we aren't going to be tempest-tossed with no moral direction. Celestial navigation and sailing as a whole provide a wealth of wonderful images and language to enliven the way we speak about, and understand, the direction of our lives.

Beauty

There aren't many things as breath-takingly beautiful as the night sky, especially seen from a place where there is little light pollution. In fact, it's breath-giving. (And speaking of pollution, there is some peace in knowing that the far reaches of the stars is one place we humans haven't left our grubby fingerprints, other than a few pieces of clunky hardware that may never get out of the solar system). Also, there is tremendous satisfaction in being able to truly place ourselves in the celestial coordinate system...our own little horizon/zenith moving and changing in the interlocking wheels of the celestial coordinates. You don't have to believe in astrology to feel major awe when you get your eyes out of the dirt and up to the "eternal beauties," as [Dante](#) puts it, *dove gioir s'insempra* ---- where joy makes itself eternal ("in-always-itself forever" - Dante was not above making up new words if he needed to).

• [Home](#) • [Why Celestial Navigation?](#) • [History](#) • [Navigational Astronomy](#) • [The Theory](#) • [The Practice](#) • [Celnav in the Classroom](#) • [Vikings](#) • [Navigational Instruments](#) • [Wayfinding](#) • [Schools](#) • [Quotations](#) • [Resources](#) • [Dante](#) • [Other Links](#) • [Webmistress](#) •

History

*Chaldean shepherds, ranging trackless fields
Beneath the concave of unclouded skies
Spread like a sea, in boundless solitude,
Looked on the pole star, as on a guide
And guardian of their course, that never closed
His steadfast eye.*

William Wordsworth, "Excursion"

The human race has been finding its way from the heavens since the beginning of recorded history, if not before. So many of the stars have Arabic names because the people of the desert used the stars for direction, as did mariners. Direction-finding, wayfinding, and steering by the stars are mentioned in ancient literature; the pilot Palinurus, in Virgil's *Aeneid*, in Book V, "watches all the stars that glide through silent skies: he marks Arcturus, the twin bears and the rainy Hyades, Orion armed with gold; and seeing all together in the tranquil heavens, loudly he signals from the stern" (another quote on [Quotations](#) page). Mathematical celestial navigation (sight reduction) came later; the "intercept" method, in use today, was invented by Commander Marcq de Saint-Hilaire of the French Navy in 1875.

I haven't found a wealth of material on the Internet on celestial navigation history, though there is some ([email](#) me if you have anything good!). There are links suitable for students in the History section of the [Celestial Navigation in the Classroom](#) page (for example, [Longitude at Sea from the Galileo Project](#) and many others. Be sure to check them out!

Out of Print Books

The Haven-Finding Art: A History of Navigation from Odysseus to Captain Cook, by E. G. R. Taylor, published by Hollis & Carter, London, for the Institute of Navigation. There are three out-of-print books I mention in this website, and this is unfortunately one of them. However, I found it through inter-library loan and it may also be available at antiquarian and used book dealers. Here is the [Table of Contents](#) which you should read before going on with this page, as it provides a good outline of the history of navigation.

A History of Nautical Astronomy, by Charles H. Cotter, William Colver and Sons, London. Another excellent history book, from the Babylonians to the publishing date of 1968.

ONLINE

[Nathaniel Bowditch Initiative Website](#)

[Secrets of Ancient Navigation](#) - From the Nova Series on PBS

[Seaman's Secrets](#) online. A fascinating nautical manual written by John Davis in 1595.

"Divided into Two Parts, Wherein is Taught the three kindes of sayling, Horizontal, Paradoxal, and Sayling upon a Great Circle...with a Regiment newly Calculated for the finding of the Declination of the Sun, and many other most necessary Rules and Instruments not hereforte set by any."

[A Short History of Sight Reduction](#) - scroll down on the webpage; it's after the java information. From "The Calculator Afloat - A Mariner's Guide to the Electronic Caluculator" by Captain Henry H. Shufeldt, USNR (Retired) and Kenneth E. Newcomer.

There is an excellent book, [Navigation in the Information Age](#), at [hawaii-nation.org](#). [Chapter Four](#) covers the western view of mapping and space through the renaissance before moving on to Hawaiian navigation. This site is also listed on the [Wayfinding](#) page.

Join [The Foundation for the Promotion of the Art of Navigation](#) and you can buy back issues of their journal for a nominal fee, a great many of which have articles on celestial navigation history.

Peter Ifland's [History of the Sextant](#) has some truly beautiful pictures.

NEW: Peter Ifland and Michel Vanvaerenbergh - [Line of Position Navigation: Sumner and Saint Hilaire the Two Pillars of Modern Celestial Navigation](#) - historical account of the development of line of position techniques from the 1840s to the 20th century.

-
- [Home](#) • [Why Celestial Navigation?](#) • [History](#) • [Navigational Astronomy](#) • [The Theory](#) • [The Practice](#) • [Celnav in the Classroom](#) • [Vikings](#) • [Navigational Instruments](#) • [Wayfinding](#) • [Schools](#) • [Quotations](#) • [Resources](#) • [Dante](#) • [Other Links](#) • [Webmistress](#) •

Navigational Astronomy

FOUR THINGS TO REMEMBER - Grasp These and You Have Heart of the Matter! *(apologies to Evelyn Waugh)*



PTOLEMY WAS RIGHT!

The first thing you have to know about celestial navigation is that its view of the heavens is pre-Copernican. That's right - you look at the earth as the unmoving center around which the sun, moon, stars, and planets turn. In other words, we deal with the heavens as if **wysiwyg** (what you see is what you get).

[Digression: Your webmistress gets to do this because this is MY page! Does the earth revolve around the sun, rather than vice versa? If I remember my high-school physics, the two bodies actually revolve around a common center of gravity, which, because of its massive size, happens to be located inside the sun. And is pre-Copernican astronomy "wrong?" We now have non-Euclidean geometries, but we still use no more than we know under Euclidean geometry to draw the lines on baseball fields, for example. I don't want to start another page on the philosopher Ludwig Wittgenstein, but if the "language game" - in this case, that of Ptolemaic astronomy - has a valid use, then there is nothing "wrong" about it. Read C.S. Lewis's [The Discarded Image](#). Digression over]

EINSTEIN WAS RIGHT!

Space and time are a continuum. In celestial navigation, time=distance. Longitude is measured in degrees, and each 15 degrees is equal to one hour (so 360 degrees equals 24 hours - one hour of the rotation of the earth corresponds to 15 degrees angle of the earth's rotation). One second of time is equal to roughly 1/4 mile at the equator, and this is why an accurate watch - one which you know the exact error of - is so important. An error in time will equal an error in longitude.

THE TRIPLE COORDINATE SYSTEM

Earth's:

Everyone is familiar with the earth's system of coordinates: the **equator**, at 0 degrees, belts the earth, and **latitude lines** running parallel to it circle the earth to the **North Pole** from 0 to 90 degrees for North Latitude and from 0 to 90 degrees to the **South Pole** for South Latitude. Vertical circles - **longitude lines** - run the other way, beginning at 0 degrees at the **Greenwich Meridian** running through Greenwich, England, and circling 180 degrees to east for East Longitude and 180 degrees to the west for West Longitude. Each degree can be further subdivided into 60 minutes, and each minute into 60 seconds (3600 seconds per degree). With this grid system, we can pinpoint the location of anything on earth by giving its latitude and longitude. For a landmark or location on earth, those numbers do not change.

Celestial Body's:

For the second grid system necessary for Celestial Navigation, imagine a great crystal globe encircling the earth. If you imagine the equator extended into space, that line will mark the **Celestial Equator**. What would be latitude lines on earth become lines of "**declination**" in space, and like latitude lines on earth, they measure angular distance north or south of the celestial equator (0 degrees) to a **North Celestial Pole** and a **South Celestial Pole** - extensions into space of the earth's poles. What we would call longitude lines become "**hour circles**" on the celestial sphere. The 0 degree hour circle (or celestial meridian) is the **First Point of Aries**; a difference from earth's longitude lines is that these lines are numbered to the full 360 degrees, rather than 180 degrees east or west.

Observer's

The third coordinate system is completely dependent upon the observer. Imagine (as all children - and some adults - do) that we ourselves are the center of the universe, the point from which all others take their bearings. The point directly over my head (which moves with me, even if I take a single step) is my "pole," or **zenith**. Its opposite, beneath my feet, is the **nadir**, a term which has little place in celestial navigation. My "equator" is my **horizon**, at 0 degrees. The distance above my horizon, rather than being called latitude, is called **altitude** (and altitude - up to 90 degrees - is what we measure with a sextant and other navigational instruments). The imaginary line running from my zenith due north or south to my horizon is my own meridian.

It's much better to visualize these coordinates than describe them. Try Walter Fendt's [Apparent Position of a Star](#) site, the figures in the celestial navigation chapter of [Bowditch's American Practical Navigator](#), or the online slide show from [Purdue's Naval ROTC](#). There is also a comprehensive Powerpoint slide show at [Penn State's Naval ROTC](#). Lessons 15-19 are on celestial navigation. There are some good line drawings at [Astronomy without a Telescope](#).

HOURL ANGLES

Geographical Position (**GP**) - imagine a string stretched from the center of the earth, through its surface, and into the center of the celestial body. The point at which it passes through the earth's surface is its geographical position. This information is in the Almanac for every day, hour and minute of the year.

A body's GP's distance from the Greenwich Meridian is its Greenwich Hour Angle (**GHA**). A body's GP's distance from where WE are is its Local Hour Angle (**LHA**). For sight reduction, we want the last, the **LHA**, to enter the Sight Reduction Tables (see [Practice](#)).

The Almanac gives us the **GHA** of everything but the stars - that would take up too much room - and instead gives us the **SHA** (a star's distance from the First Point of Aries is its Sidereal Hour Angle or **SHA**), which we can then convert, and worksheets help us figure the **LHA** by using our longitude.

SPECIAL [Helmer Aslaksen](#) has some wonderful Java Applets and video clips on his page for teaching astronomy - scroll down to find them. He also has a link to Nick Strobel's [Astronomy without a Telescope article](#), a great resource for understanding the astronomical concepts behind celestial navigation.



The book [The Stars: A New Way to See Them](#), by H.A. Rey, explains just everything you need to know about astronomy in order to understand celestial navigation - why sidereal (star) time is four minutes off solar time, how to understand the relation of Polaris and Latitude, what the Ecliptic is, the Precession of the Equinoxes, etc. Also, it has wonderful redrawings of the constellations so they are easily recognizable. I can't recommend this book enough for anyone who is coming to astronomy for the first time and anyone who thinks they know it all.

Not all the stars in the sky are used in celestial navigation. The almanac lists data for [57 Navigational Stars](#), including the 20 brightest in the sky.

-
- [Home](#) • [Why Celestial Navigation?](#) • [History](#) • [Navigational Astronomy](#) • [The Theory](#) • [The Practice](#) • [Celnav in the Classroom](#) • [Vikings](#) • [Navigational Instruments](#) • [Wayfinding](#) • [Schools](#) • [Quotations](#) • [Resources](#) • [Dante](#) • [Other Links](#) • [Webmistress](#) •

Theory



Teering by the stars, finding routes and locations by them, and orienting oneself from the positions of celestial bodies is the ancient art of [Wayfinding](#), or non-instrument navigation. People have been wayfinding since the beginning of history because the stars are (relatively) fixed markers. This page will concentrate on the theory behind modern celestial navigation, what is called "modern," "mathematical," or "instrument" celestial navigation.

Just about everything on theory and practice is in [Bowditch's American Practical Navigator Online](#), but it's not an easy place to start. I will try to make this page as concise as possible.

The basic theory behind Celestial Navigation is simply that we find our unknown position from a known position. If we have some information, we can deduce the rest.

For example, if we know we are three miles from a flagpole, we could be anywhere on a circle with a three-mile radius and the flagpole as its center. If we knew the bearing of the flagpole (the compass direction, such as 135 degrees or Southeast), we could fix our exact position on the circle. **Or** if we knew bearings from two objects spaced a reasonable distance apart, we could draw straight lines on a map or chart along those bearings from each, and where the lines crossed, there we are.

This is fairly easy to do on land or on the coast, where we can find our position from known landmarks on charts and maps. On the open ocean, it's a different story, as there are no landmarks. We can't take a bearing from an object as distant as the sun or a planet, because the compass is too clumsy an instrument. It measures in degrees, while a sextant measures in degrees, minutes, and seconds (there are 3600 seconds in a degree). [The sextant does not give us a bearing, or azimuth, to a celestial body, but gives us information that helps us find the azimuth].

The stars pretty much stay in the same place - that's why they were known as the "fixed stars" throughout history, except they rise and set; the sun, moon, and planets move, but predictably, and so with the aid of almanacs that tell us precisely where each body is at every second of every minute of every hour of every day of the year, and the practice of "sight reduction" (see [Practice](#)), we can take a position from two or preferably three stars, or planets, or the sun and moon when both are visible, or the sun at different times of the day, and where the lines of position cross is where we are.

Before going on to [Practice](#), this is what you need to know:

"Modern" celestial navigation is based on spherical trigonometry and solving the "**navigational triangle.**" (IMPORTANT: DON'T PANIC IF YOU DON'T KNOW TRIGONOMETRY! TABLES OR SOFTWARE DOES ALL THE WORK FOR YOU AND YOU ONLY NEED TO KNOW ADDITION AND SUBTRACTION TO NAVIGATE!) This is a triangle on the earth's surface with:

- 1) The North (or South) Pole as one corner,
- 2) The "Geographical Position" (GP*) of the celestial body as another, and,
- 3) Our Assumed Position (AP*) as the third.

The sides are:

- 1) the Pole to our assumed position (or 90 degrees minus our assumed latitude);
- 2) the Pole to the GP or 90 degrees minus the body's declination*;
and
- 3) from our assumed position to the GP or 90 degrees minus the calculated height of the body above the horizon (our "zenith distance").

We are able to find the first two sides and the angle included in them, because we know our assumed latitude, can find the body's declination at that moment from the Nautical Almanac, and can figure the angle - the Local Hour Angle - from our data.

With this information, we can find the third side - our distance from the GP - and the angle or direction to the GP. For accuracy's sake, it is best to use at least two or preferably three bodies; where the lines of position cross on our chart will be a point, or more likely a small triangle called a "cocked hat," which is our location.

**GP - imagine a string stretched from the center of the earth, through its surface, and into the center of the celestial body. The point at which it passes through the earth's surface is its geographical position. This information is in the Almanac.*

**AP - The spot chosen as a reference point upon which to base our calculation. It is reasonably close to where we actually are if we base it on "dead reckoning" (having kept track of our position by recording speed and direction). Explained further under Practice.*

**Declination - see [Navigational Astronomy](#). Similar to the earthly coordinate latitude, it is the star's distance in degrees above the celestial equator.*

Finding latitude by Polaris, and taking noon sun sights, do not require solving the navigational triangle. They involve simpler right triangles. For example, the sun at noon - real noon, that is, when the sun is at its highest point, on our meridian - is either due north or south of us, and our line of position is then due east or west. An east-west line is a parallel of latitude. These two are easiest to teach beginners. A [simple explanation of latitude by Polaris](#) is available (however, it does not include reference to the corrections that are necessary because Polaris is not precisely North, but a bit under a degree away).

- [Home](#) • [Why Celestial Navigation?](#) • [History](#) • [Navigational Astronomy](#) • [The Theory](#) • [The Practice](#) • [Celnav in the Classroom](#) • [Vikings](#) • [Navigational Instruments](#) • [Wayfinding](#) • [Schools](#) • [Quotations](#) • [Resources](#) • [Dante](#) • [Other Links](#) • [Webmistress](#) •

The Practice



Yogi Berra said, "In theory, there should be no difference between theory and practice, but in practice, there is." This website cannot teach the actual practice of celestial navigation; however, by reading these pages, you should be able to move on to an on-site or correspondence course with an understanding of what you are doing. If you are new to Celestial Navigation, read at least the [Theory](#) and [Navigational Astronomy](#) pages

first.

[Ed Falk's awesome page](#) working out a sample "leg" from the Silicon Sea series of problems. Crystal clear, complete with plotting sheets and everything you need to see a problem worked out in detail!

Just about everything on theory and practice is in [Bowditch's American Practical Navigator Online](#). *(I have changed the link - this one has all the tables as well)*. The practice of some early techniques of latitude finding and navigation without instruments can be found in the books [Latitude Hooks and Azimuth Rings](#), and in David Burch's magnificent [Emergency Navigation](#), which everyone should own (it's not just for emergencies!). Bowditch has a chapter on emergency navigation as well.

SIGHT REDUCTION: WHAT YOU WILL NEED

You will need a sextant, a watch, a current-year [Nautical Almanac](#) (or see Omar Reis's [Almanac](#)) and the Tables of your choice, probably [HO 249](#) or [HO 229](#). For shooting stars, a Star-Finder would also help; you can buy the 2102-D, a kind of modern planispheric astrolabe, and there are some online, such as - once again, and what would we do



without him? - Omar Reis's [Starfinder](#). (See Products on the [Resources](#) page if you want to purchase almanacs, tables, or Star-Finders. Try Geoffrey Kolbe's [long-term almanac](#) if you don't want to buy a new one every year). You can also do sight reductions with a calculator - I think Starpath's [Starpilot](#) is the best; check out the list of features -it's much

more than a calculator and can be linked to your PC - but learn to do them with just a pencil and paper first. NOTE: You can take sights with an artificial horizon if you aren't near the water. Check out the Product places on the [Resources](#) page. Be sure to read the instructions; you have divide the angle by two when using an artificial horizon. You can also make one by using a flat pie pan filled with water, or preferably oil. **NOTE:** The sextant can only measure up to 60 degrees with an artificial horizon and so cannot be used at all latitudes.

WHAT YOU ARE DOING:

With the modern "intercept" method, you will be comparing the position you *think* you might be in (from dead reckoning on a boat, or other data on land) with what you actually observe. Your **observed altitude (steps 1-3 below)** is compared to a **calculated altitude (steps 4-5)** - calculated to be what altitude you would get if you were actually at the position you chose as your assumed position. Therefore, you must *both* observe an actual altitude with the sextant; and figure, on worksheets and with the Tables, what the altitude would be if seen from the assumed position.

Remember: Noon (meridian) sun sights and Polaris sights do not require the Tables to solve the Navigational Triangle. See [Theory](#).

NOTE: Your sextant must be corrected first. The sextant is a precision instrument, but like a bathroom scale can be off, either up or down. See [John Jacq's Corrections page](#) under "Sextant Error," or any of the books recommended below.

THE STEPS:

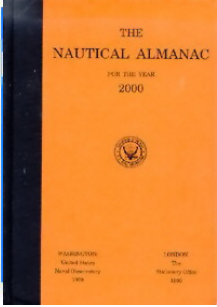
1. Setting up: deciding what celestial body you are going to "shoot" and when. This is especially important in star sights, as you only have the short time between civil and nautical twilight when the horizon is still visible, while some stars are bright enough to be seen. Civil and nautical twilight time are found in the Almanac for various latitudes. Find stars with Reis's online [Star-Finder](#). Or purchase the [2102-D Star Finder](#) from Starpath. To find nautical and civil twilight, use the [Navy's one-year data page](#). Don't forget to check the "type of table" you want (also has sun and moon rise and set).
2. Shooting the body and noting the exact time. (Your watch must be corrected if it is fast or slow on Universal Time - Greenwich Mean time - and corrected for your longitude east or west of the Greenwich meridian. You will be using UT (GMT) when you enter the Almanac. Check your watch against the [Navy's Master Clock](#).
3. Correcting your sextant shot for various corrections such as your height of eye above the horizon, your sextant's index error, altitude corrections etc. Some of these corrections are in the Almanac; the others depend on you and your instrument. These are found in tutorials; see, for example, Chapter 2 of [Henning Umland's](#). THIS WILL GIVE YOU YOUR OBSERVED ALTITUDE.
4. Entering the Nautical [Almanac](#) for the body's data at that precise time. The Almanac gives data for each hour of every day, with extra pages where you can find the minutes and seconds. There are some corrections to be made here. (Print Almanacs are available from the Products places on the [Resources](#) page), notably the "v" and "d" corrections. If you purchase one, make sure the Almanac looks like one of these (I have a commercial edition that is slightly different, but still with a blue cover). In six marine stores out of six, when I asked for the Nautical Almanac this year, I was handed Reed's or worse, Eldridge's (mostly tide tables!). Neither of those has all the information you need. These are the American versions; the orange is the hardcover government edition.
 
5. Entering the **Tables** for sight reduction with the a) Local Hour Angle, (found by correcting the body's Greenwich Hour Angle from the Almanac for your particular assumed longitude), b) your assumed latitude (see [Find your latitude and longitude](#) if doing this on land), and c) body's declination (from the Almanac) to find the calculated height of the body if you were where you assumed yourself to be. (NIMA has the sight reduction tables for [Air Navigation - HO 249](#) and the [Marine Navigation - HO 229 tables online](#)). **Hour angles are defined on the [Astronomy page](#)**. THIS WILL GIVE YOU YOUR CALCULATED ALTITUDE as well as the true bearing of the body.
6. Comparing the altitude you got - the OBSERVED ALTITUDE - with the CALCULATED ALTITUDE from the tables and deciding whether you are closer or farther away than the calculated position. (If the calculated altitude is greater, you are farther away from the assumed position; if it is less than the corrected sextant altitude, you are closer; the difference between the two is the number of nautical miles by which you need to change

your assumed position).

7. Plotting the line of position. Two or more give you your fix - where you are. (see Ed Falk's [plotting sheet](#) page).

Many of these steps are very easy and automatic once you have a worksheet with all the steps and spaces for corrections. It becomes simply a matter of filling in the spaces, and adding and subtracting. Ed Falk also has a sample [worksheet](#) - H_s is the height you get with the sextant; IE is the sextant's index error; H_c is the calculated height from the tables, etc.

NEW! There are also PDF worksheets available on the [Reader Page](#) sent in by reader Harold Arsem.

The resources below will help:

CLASSES AND HOME STUDY

The very best place to get a real grip on the practice, in my opinion, is by taking a good course with an expert, especially one that gets you out on the water or at least to a horizon line. If there isn't a school or teacher near you, the course available from the [Starpath School of Navigation](#) is the best. I took this course and I cannot say enough good things about it, or recommend it more highly. The price is absolutely amazing considering that some places want to charge hundreds of dollars for a single weekend. If you work your way through the text and problems, and take advantage of the fact that the price of the course includes phone calls and emails with one of the world's top instructors, and navigators**, you'll see they're practically giving it away, and you'll learn everything you need to know, and more.

***Don't take my word for it - ask the Royal Institute of Navigation.*

ONLINE TUTORIALS

There is a great online tutorial by [Al Placette](#) that walks you through much of what is needed for reducing a sight by H.O. 229, including digitized parts of the Nautical Almanac to show you how to make v and d corrections. (The "v" is an extra correction for additional longitude movement of the body, and "d" is an extra correction for additional declination movement. The sun has no "v" correction and the stars have no "v" or "d" correction. The sun needs the "d", and the planets and moon need both "v" and "d"). This site isn't always available, but worth waiting for. **One of the best on the Net.**

Another really excellent site is [Umland's Short Guide to Celestial Navigation](#). Parts are really for advanced students, but there is plenty for beginners, including very clear graphics. Scroll through the chapters and look them over, and check out Chapter 2 on how to make all the various sextant corrections. There is also an extensive collection of freeware - a Sun and Moon Almanac, Sight Reduction Calculator, Fix Calculator, and more - on his [Freeware](#) page. **Another of the best on the Net.**

The Naval ROTC at Purdue has some [Navigation Slide Shows](#) (scroll down the syllabus and select), but unfortunately have removed the vast majority of the slides on celestial. A [Powerpoint Slide Show](#) (you need the software) is at Penn State's Naval ROTC (see chapters 16-19).

[The Irreverent Navigator](#) has a tutorial that includes jpegs of worksheets and explicit instructions. The page is primarily very dense type - not often divided into paragraphs - so it may be a bit harder on the eyes than the more graphic page above.

OTHER HELP

Join [The Foundation for the Promotion of the Art of Navigation](#) and you can write to their journal and get expert advice. There are also detailed articles on all aspects of navigation and its history.

[The Navigation List](#) is an email list for traditional and electronic navigation; check the archives for technical questions, or join and ask one. Here is their [archive site](#).

William F. Buckley, Jr., has a great chapter on how to do sun sights in his book on a transatlantic crossing by sail, *Airborne: A Sentimental Journey* (1970). It is unfortunately out of print, but you can usually find it at libraries. It's about 18 pages long, uses the *Air Almanac*, and is concise and clear (I know, I know; but no, he doesn't use his \$1,000-a-word vocabulary here). An added bonus is that his son Christopher went on this trip, and his log entries show that he was already, at that age, a writer in his own right. Whenever a wine bottle was emptied, it was the custom on the boat to write an anti-Communist message and send it to sea in the bottle. One of Christopher's submissions: "Man is born free, and everywhere he is running out of Branc-Cantenac." (all politics aside, this is still very witty!). I haven't seen his [video](#), but I'll bet it covers the same ground as this chapter.



Books:

There are many, many books on the practice of celestial navigation - do a search at

Amazon.com and you'll see. These are my favorites:

[Practical Celestial Navigation](#) by Susan P. Howell. [Mystic Seaport](#) also has this. It is actually a course, and everything you need (copies of necessary almanac pages and sight-reduction tables) is in the book.

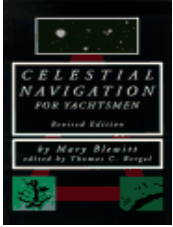

[Celestial Navigation for Yachtsmen](#) by *Mary Blewitt*. This book is short and to the point, and many people swear by it.

Online Almanacs, Starfinders, Latitude-Longitude Finders, and Programs for Sight Reduction

- [H. Umland's Freeware Page](#)
- [Palm Pilot Celnav Program](#)
- [Java Script Programs for Navigators by Jacky Wong](#)
- [Omar Reis's Navigation Star Finder](#)
- [Omar Reis's Online Nautical Almanac](#)
- [Omar Reis's Navigator Light Computer Program](#)
- [W. Fendt's Apparent Position of a Star Astronomy Java Page](#)
- [W. Fendt's Coordinate Graphic \(Celestial Poles\) Java Page](#)
- [Almanac and Sight reduction Information from the Navy](#)
- [ETAK's latitude and longitude site](#)

SOFTWARE

[AstroNav Software](#) by Her Majesty's Nautical Almanac Office. Check out the other pages at the Willmann- Bell site too, such as **[Math and Celestial Mechanics](#)**.

[Pocket Stars](#) Integrated Star Chart, Ephemeris, and Celestial Navigation Software for the Pocket PC.

["Celestial Navigation for Dummies"](#) and two software programs - ASNAv, "designed by a seaman for seamen," and DeltaWin, at [marinesoft.org](#).

Celestial Navigation in the Classroom

[Science and Math Projects](#) [Teachers' Guide](#) [History](#) [Reading](#) [Literature](#)
[Books](#)

I have found that students of all ages quickly become interested in celestial navigation, as it provides a concrete link between the heavens and themselves, one that fills some of them with awe and amazement. It is a subject about which most of them know nothing at all, so it has the added attraction of novelty. At some simple level - basic orienteering and latitude finding - they can very easily learn to do it themselves. Older students can learn to use the sextant. And even most adults have an extremely limited understanding of astronomical or navigational metaphors, so whole new worlds open up to them once the original use behind the metaphor is grasped.

SCIENCE AND MATH CLASSES



Astronomy classes are the most obvious place to start. It always amazes me how little most students know about the sky - usually they can identify the Big Dipper and Orion but little else. I think the all-time best book for explaining the astronomy you need for understanding celestial navigation is H.A. Rey's [The Stars: A New Way to See Them](#).

Yes, that's the same H.A. Rey that gave us the "Curious George" children's books. Not only does the book redraw the constellations so that they look like what they are called, and so are very easy to find, but it has crystal-clear illustrations that explain why sidereal time is off solar time by four minutes; just what declinations and hour angles are; the ecliptic; the precession of the equinoxes and why Polaris hasn't always been the North Star; the celestial coordinate system, and more. Highly, highly recommended for anyone of any age.

See also the [Navigational Instruments](#) page and the [Navigational Astronomy](#) page for further resources.

[ASTRONOMY ONLINE](#)- "The World's Biggest Astronomy Event on the World Wide Web," has a page on finding latitude by Polaris. There are a number of graphics which take time to load - they're worth waiting for. Here is a sample link from the main page: [Is the Altitude of Polaris Equal to Your Latitude?](#)

[EYES ON THE SKY, FEET ON THE GROUND](#) - From the Smithsonian Astrophysical Observatory. [Chapter 4](#) has Coordinate System and Celestial Mapping activities for

children include an astrolabe and star plotter, finding your latitude, etc. Scroll down to topics three and four.

[CULTURAL ASTRONOMY](#) - don't miss this completely unique (yes, I know that's redundant!) site from Helmer Aslaksen. See my ["Other Links"](#) page.

[ASTRONOMY WITHOUT A TELESCOPE](#) by Nick Strobel - terrific notes and diagrams - evrything you need for "naked eye" astronomy, and hence celestial navigation! Don't miss this site!

Lesson Plan for [NAVIGATING AROUND THE WORLD BY OBSERVING THE SUN](#) - from the PBS Nova series.

Also, be sure to check out [Nova's Shockwave Game on Finding Your Latitude](#).

Math: Celestial navigation in its modern form is based on solving spherical triangle problems (the "navigational triangle") and there is a good site for [Navigational Trigonometry](#), but your students don't have to be taking trigonometry to use celestial navigation. Finding latitude by the meridian passage of the sun or by Polaris only requires addition and subtraction, as does sight reduction using pre-calculated tables. (If you do want the trig, try the advanced tutorial that H. Umland has online: [Umland's Short Guide to Celestial Navigation](#)).

PROJECTS

Online Projects

- [How to Make a Quadrant](#)
- [How to Use a Quadrant](#)
- [Other Projects with Quadrant](#)
- [Measuring North Latitude at Night](#)
- [How to Use a Cross-Staff](#)
- [Build Your Own Sextant](#)

Otterbein College Department of Physics and Astronomy has a [Make your own planisphere](#) page. You need a PDF reader to download the templates.

KITS: [Celestaire](#) sells kits for making a working [nocturnal](#), [astrolabe](#), and [mariner's astrolabe](#), made of heavy cardboard stock coated with a metallic gold finish. They also make a sundial and perpetual calendar. I have made all these things, and they work. **NEW** - the new Celestaire catalogue has a kit for a [laminated cardboard sextant](#) with mirrors and adjustable sun shade! I haven't tried this one yet, but I will. There is nothing like building a working model to really show kids how something works!

TEACHERS' GUIDE

The [Celestaire](#) company has a booklet called ***Celestial Positioning: A Teacher's Guide to and Earth Science Project with History, Mathematics and Astronomy Integration*** which is available free to teachers. Write and ask for it; I haven't seen it on their website. This guide is NOT online but it has a clear summary, a basic project, and a catalogue where you can order an inexpensive plastic sextant, all kinds of books, and my favorite project, the working instruments described above.

Note that you can take sights with an artificial horizon --- check the Products places on the [Resources](#) page.

HISTORY

First, be sure to check the [History](#) page!

You can do classes that cover latitude sailing during the Age of Exploration; with no sure-fire way to figure longitude, it was safer to sail up or down the coast until you reached the latitude of your destination (as shown by the taking the altitude of stars), then sailing east or west. Supposedly old sailing directions to the Caribbean were, "Sail south till the butter melts, then west." Then there is the history of the Longitude problem ([*Longitude: The True Story of a Lone Genius Who Solved the Greatest Scientific Problem of His Time*](#)) and the invention of the chronometer, for a unit on time. See [John Harrison and the Longitude Problem](#). To understand the Middle Ages and the Ptolemaic view of the universe, I would strongly suggest C.S. Lewis's underused classic, [***The Discarded Image***](#), for high school or college students.

- [Teacher's Guide to Teaching Longitude](#) - from PBS, with resources. A transcript of PBS's video *Lost at Sea* is [here](#). See also [The Secrets of Ancient Navigation](#).
- [Navigation During the Time of Columbus](#)
- [Secrets of Ancient Navigation](#) - PBS on the Phoenicians, Norsemen, Chinese, etc.
- [Latitude: The Art and Science of 15th and 16th Century Navigation](#) - Excellent site for students with many informative links; see for example the link for [pre-1400 navigation](#).
- [Christopher Columbus Navigation Page](#), with a [Celestial Navigation](#) page.
- [The Age of Exploration](#) from the Mariner's Museum
- [Determination of Latitude by Sir Francis Drake](#) - a page by Bob Graham.
- [Longitude at Sea from the Galileo Project](#)
- [How Columbus and Apollo Astronauts Navigated](#)

American History



Why isn't there more online about **Nathaniel Bowditch**? This Salem resident was entirely self-taught in mathematics and astronomy (and taught himself Latin so he could read Newton's *Principia*), and had such a great effect on celestial navigation that his book, [*The American Practical Navigator*](#) (originally published in 1802), is still called "Bowditch" after many revisions. A children's biography is available (see under Reading, below) and online are:

[Short Biography of Nathaniel Bowditch](#) - I had to go to the United Kingdom for this one!

[Nathaniel Bowditch Initiative Website](#)

Did you know that slaves in the **Underground Railroad** used celestial navigation? The following is from the description of a video I have not seen from NASA and the National Park Service called [The Underground Railroad: Connections to Freedom and Science](#):

"Slaves traveling the Underground Railroad, usually on foot, depended on celestial navigation to find their way northward. They continually looked to the Big Dipper and the North Star for direction. The purpose of this video is to increase student awareness of the Underground Railroad and the role celestial navigation played in the Railroad's success."

American explorers **Lewis and Clark** used celestial navigation. There is a good article in [Spring 2000](#) issue of the Institute of Navigation's online journal. Scroll about halfway down to "Portney's Corner." A short articles on [Formal Navigation by Lewis and Clark](#), [Course, Time and Distance](#), and [Latitude and Longitude](#) are available at the excellent Lewis and Clark site at www.lewis-clark.org.

NEW BOOKMARK AND MUCH MORE INFORMATION A reader has suggested a link on [David Thompson](#), who explored and mapped Western Canada and the Northwest of the US from 1790-1812, using a sextant and compass. [Now online are ten detailed articles](#) from the issue of Northwest Journal devoted to 19th century navigation.

Viking Navigation

The Vikings are enjoying a bit of a Renaissance lately, in print and on the web, and in events such as the new Viking Exhibit now at the Museum of Natural History in New York. Apparently the marauders were only a small subset of a very interesting society. Longships, sun compasses, the sagas of the Norse gods --- the Vikings are always a favorite subject for classrooms. And no, they never wore horns on their helmets. See my [Viking Navigation](#) page, where there are books nad websites available.

Non-instrument Navigation

There is a wealth of material on the Internet on Polynesian star navigation and non-Western navigation in general. Captain Cook was astounded at the advanced navigational skills of the people of the South Seas. See my page on [Wayfinding](#)

AFRICAN AND NATIVE AMERICAN: There is also a VERY interesting website called "[Aboriginal \(Native American\) Astronomy](#)" on star lore and Lakota astronomy. [African Star Lore](#) is another good site.

READING

Once, to tempt a middle-schooler who did not want to read any books during the summer, I mentioned how Steven Callahan was able to navigate using a sextant made of pencils tied together and survived 76 days at sea. This student proceeded to devour Callahan's account, [Adrift](#) (kids love harrowing adventure tales). In [My Old Man and the Sea](#), a father and his teenage son sail around Cape Horn, using no electronic navigation devices - just a sextant and compass. Then there is a Newbury Award-winning, fictionalized account of Nathaniel Bowditch's (see above) life and work called [Carry on, Mr. Bowditch](#) by Jean Lee Latham.

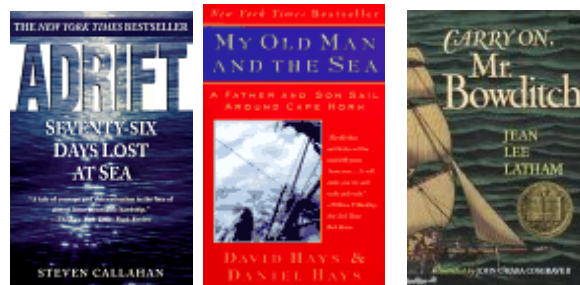

LITERATURE

My graduate thesis was on [Dante](#), so I have a page just for him. Knowledge of celestial navigation and of the stars and constellations will enhance your students' understanding of Melville, (and don't forget the wonderful new novel, *Ahab's Wife, or the Stargazer*) Conrad, Spencer, Ovid, Shakespeare, Pope, Milton, Longfellow, the entire Western canon, Arabic and other eastern literature...well, just about everything. Reading much of the world's literature without a knowledge of these things would be like reading most Western literature of the past two thousand years with no knowledge of the Hebrew Scriptures and New Testament - a huge percentage of the allusions and metaphors would fly over your head. See also my [Quotations](#) page (a work in progress). BTW, [Chaucer's History of the Astrolabe](#) is online as well.

BOOKS

- [*Latitude Hooks and Azimuth Rings*](#), by Dennis Fisher
- [*The Stars: A New Way to See Them*](#) by H.A. Rey
- [*Longitude: The True Story of a Lone Genius Who Solved the Greatest Scientific Problem of His Time*](#) by Dava Sobel
- [*Navigation in the Age of Discovery*](#), By Duane A. Cline
- [*Taking the Stars: Celestial Navigation from Argonauts to Astronauts*](#) by Peter Ifland
- [*Emergency Navigation*](#) by David Burch
- [*The Discarded Image*](#) by C.S. Lewis
- [*Carry On, Mr. Bowditch*](#), by Jean Lee Latham
- [*Adrift*](#), by Steve Callahan
- [*My Old Man and the Sea*](#) by David and Daniel Hayes
- [*Line of Position Navigation: Sumner and Saint Hilaire - the Two Pillars of Modern Celestial Navigation*](#) by Peter Ifland and Michel Vanvaerenbergh

-
- [Home](#) • [Why Celestial Navigation?](#) • [History](#) • [Navigational Astronomy](#) • [The Theory](#) • [The Practice](#) • [Celnav in the Classroom](#) • [Vikings](#) • [Navigational Instruments](#) • [Wayfinding](#) • [Schools](#) • [Quotations](#) • [Resources](#) • [Dante](#) • [Other Links](#) • [Webmistress](#) •

The Vikings



The 1,000 year anniversary of Leif Eiriksson's Voyage to North America has led to an explosion of information on the Vikings. The above is the [Islingur](#), a replica of an 870 AD Viking ship that voyaged from Iceland to New York City between June and October of 2000. The man on the far right is Captain Gunnar Eggertsson, a direct descendent of Leif, who built the Islingur. The other two are crew members. My son's [Sea Scout Ship](#) was an official escort at one of Islingur's stops, and your webmistress sailed through a glorious starry night to rendezvous with the Viking ship.

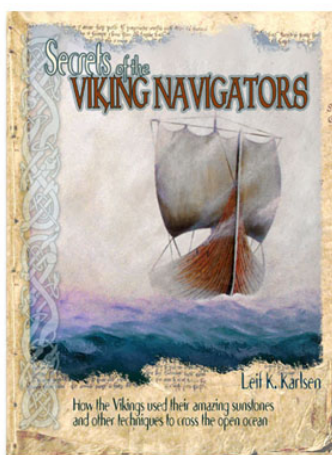

New book: [Secrets of the Viking Navigators](#)

Although this site is on navigation, [here](#) is a good "hub" for general information on the Vikings on the Internet, and here are links specifically about Vikings and navigation:

- [Viking Navigation](#) from the Longship Company
 - [Viking Navigation and Astronomy](#)
 - [Viking Navigation](#) from the Mariner's Museum
 - [The Legend of the Viking Sunstone](#)
 - [Viking Sun Compass](#) from the Northern Lights Planetarium in Norway
-

• [Home](#) • [Why Celestial Navigation?](#) • [History](#) • [Navigational Astronomy](#) • [The Theory](#) • [The Practice](#) • [Celnav in the Classroom](#) • [Vikings](#) • [Navigational Instruments](#) • [Wayfinding](#) • [Schools](#) • [Quotations](#) • [Resources](#) • [Dante](#) • [Other Links](#) • [Webmistress](#) •

Navigational Instruments

The main instruments mariners need for Celestial Navigation are the chronometer and some way of measuring the altitude of bodies above the horizon. There are good pictures and history of the former at [John Harrison and the Longitude Problem](#). The latter can be as simple as your hand span, a ruler, or a couple of pencils lashed together or as sophisticated as a modern double-reflecting sextant, which measures in seconds of arc. The [Classroom](#) page has links to projects for making some of these instruments, and the book [Latitude Hooks and Azimuth Rings](#) by Dennis Fisher has instructions for all of them. [Celestaire](#) sells gold-colored cardboard kits for making a working [nocturnal](#), [astrolabe](#), and [mariner's astrolabe](#).

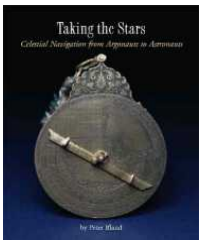

THE book to own is Peter Ifland's beautiful and thorough [Taking the Stars: Celestial Navigation from Argonauts to Astronauts](#). His [lecture](#) (see under Sextants, below) has many beautiful pictures of different instruments.

And THE place to go for historical pictures and information is ["Scientific Instruments of Medieval and Renaissance Europe."](#)



****NEW!** DON'T MISS OMAR REIS'S [INTERACTIVE SEXTANT](#)

ONLINE! He also has a ["Build Your Own Sextant"](#) page. Celestaire sells the [cardboard sextant kit](#).

LATITUDE HOOK, KAMAL



Kamal

These are among the simplest methods of measuring altitude. The latitude hook of the Polynesians was a piece of split bamboo with a loop at the top; its length was aligned with the horizon and star to show when the desired latitude had been reached.

The Arabs used a more refined tool called the kamal, a rectangle of wood cut to fit the distance from

the horizon to the star. It had a piece of knotted string attached, which could be held in the teeth, guaranteeing that an "arm's length" distance would remain uniform. The photo is from Peter Ifland's site - click on it.

CROSS-STAFF AND BACKSTAFF

The cross-staff measures up from the horizon to the body rather than down from the zenith, since the horizon is a clear and definite line (well, on good days!). This was an advance over zenith devices and could be done by one person. A wooden staff is placed on the cheek and a crossbar is slid along its length until it fits between the body and the horizon. The backstaff was invented in 1590 by John Davis (see his [Seaman's Secrets](#)), and allowed the navigator to stand with his back to the sun, working with its shadow.

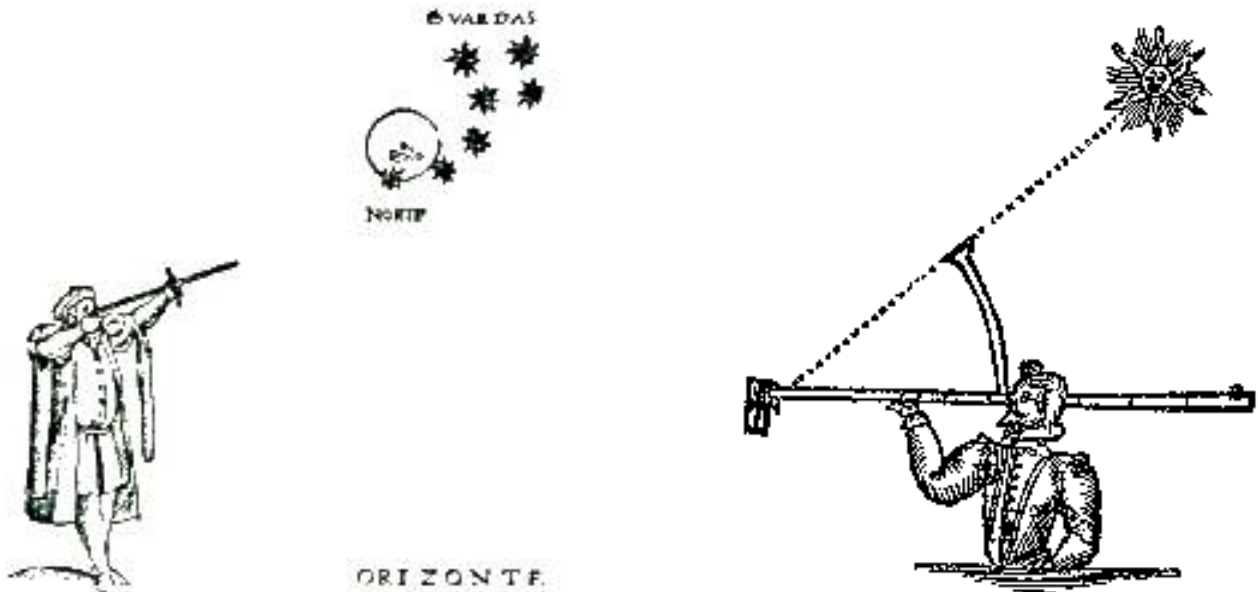

Cross-staff

Back-staff

QUADRANT



This instrument, shaped like a quarter of a circle, measured the angle from the vertical - not horizontal - and the line of sight to the body. It was suspended from a ring and had a weighted line hanging down, which crossed one of the angle numbers marked on the ring. Columbus used one, but after trying it, it's hard to imagine how it was held stable!

ASTROLABE



Mariner's Astrolabe



Astrolabe

The first part of its name comes from the same Greek word that gave us "astronomy" - aster, or star - and the second derives from a Greek word meaning take, grasp, or determine. So the name can be translated as "star-finder" or "star-taker." The astrolabe is an instrument that provides a picture of how the sky looks at the observer's latitude and time. It has moveable parts that allow it to be set for specific dates and times, and interchangeable templates that allow latitude to be set. Besides showing the position of the sun and stars, the astrolabe can measure the altitude of the body, and the Mariner's Astrolabe eliminated all the parts that weren't necessary for this use. Like the quadrant, it had to be held

vertical so that the zenith distance (degrees down from the point over the observer's head to the body) could be measured. Subtracted from 90 degrees, this gives the altitude, and for the Pole Star, this was an approximation of the observer's latitude. A modern version is the 2102-D Star-Finder - See [Practice](#). The photos are by Norman Greene - click on them for his website.

NOCTURNAL



The nocturnal was used to tell time by the celestial clock. One ring was set to the date, Polaris was sighted through the hole in the center, and the arm was swung around to align with pointer stars - those in the Big Dipper, Little Dipper, or Cassiopeia. Where the arm crossed the marked ring, the time was read.

It was also used to measure Polaris's distance in minutes of arc from true north so a correction could be applied.

Here are good sites for the instruments named above:

- Richard A. Paselk has an excellent site on [Medieval Scientific Instruments](#) which shouldn't be missed, especially the pages for the [kamal](#), [cross-staff](#), and [quadrant](#). There are instructions for making and using them. He also has some of the best pictures on the Internet of the [Mariner's Astrolabe](#) and [Planispheric Astrolabe](#).
- [Hands-On Astrolabe Page](#), with history. You can download templates for your latitude to make your own astrolabe.
- [Keith Powell's Awesome Java Astrolabe](#)
- [Chaucer's Treatise on the Astrolabe](#)
- [www.astrolabes.org](#) (note the plural). Everything you ever wanted to know, plus a free download of the author's Electric Astrolabe program. The book you download as part of the program has an excellent history.



The Sextant

The double-reflecting instrument (one that uses two mirrors to bring the celestial body down to the horizon; hence the navigator no longer has to try to look two places at once) was apparently invented by Newton in 1699, though it was London mathematician John Hadley who got the credit for first producing one in 1731. To complicate matters, American inventor Thomas Godfrey built one in 1730, but was not acknowledged by the Royal Society. Hadley's second instrument had an arc of 1/8 of a circle and hence was called an octant; the sextant is 1/6 of a circle. Here is Bruce Bauer's definition: "A sextant is, in essence, a machine for varying the angle between two mirrors by precisely measurable numbers of degrees to utilize the

phenomenon that the angle of the departing light ray will have been changed by double the angle between the mirrors." Bauer's [The Sextant Book](#) (International Marine, Camden, 1992), is the bible for this instrument, and covers adjustment, repair, use, and history.

PBS has a page on [How a Sextant Works](#) as well as [Navigation By Sextant](#).

HIGHLY RECOMMENDED: Peter Ifland's lecture, [THE HISTORY OF THE SEXTANT](#), delivered in Portugal in October 2000. There are some absolutely beautiful pictures on this site.

See Products on the [Resources](#) page for some places to buy sextants. A plastic model is available for about \$30.

-
- [Home](#) • [Why Celestial Navigation?](#) • [History](#) • [Navigational Astronomy](#) • [The Theory](#) • [The Practice](#) • [Celnav in the Classroom](#) • [Vikings](#) • [Navigational Instruments](#) • [Wayfinding](#) • [Schools](#) • [Quotations](#) • [Resources](#) • [Dante](#) • [Other Links](#) • [Webmistress](#) •

Wayfinding

While the development of scientific navigation was proceeding in the West, the people of the South Pacific had been navigating with confidence over thousands of miles of nearly empty ocean using no compasses, charts, or sextants. They looked upon navigation not merely as a technique of getting from one island to another, but as a *way* - a combination of philosophy and religion, a way of life into which one was initiated. Navigators were held in as high esteem - or higher - than the leaders of the societies. They knew the sky the way we know the face of the people we love, even if parts were obscured.

Steering by the stars was more complex than some people have made it out to be. It wasn't just (for example) "following the North Star," but a very intricate system of starpaths that depended on the rising and setting of various stars, the knowledge of a of a 32-point star compass, a method of taking "back bearings" called *fatanomuir* (looking back over the stern to find the star under which an island has moved), a kind of "ranging" called *fu taur* or star channel (lining up a known feature with star point to make a night landfall through a reef channel) and much, much more. To become adept at this required many years of training, and not everyone reached the point of being a *palu*, or fully initiated navigator.

One who did said that the true navigator reaches a point where it is not that you go out in search of the island; instead, you point your boat in the right direction, and the island comes to you.

This is just the combination of knowledge, intuition, and discipline that appeals to your Webmistress.

Websites:

[Traditional Navigation in the Western Pacific](#) - from the University of Pennsylvania

[Pacific Voyaging Society](#) - This is the best site on the web for this topic. You could spend hours at this site, which includes details of the voyages of the *Hokule'a* and *Hawai'i'iloa*, reconstructed outrigger sailing canoes in which sailors recreated the ancient navigation techniques on long voyages. It includes a [bibliography on wayfinding and astronomy](#), how the wayfinders determine [latitude](#), how they determine [position east or west](#), the article [Wayfinding, or Non-Instrument Navigation](#), a [Star Compass](#) page, and much, much more.

[Navigation in the Information Age: History and Context](#) - by C. Cogswell and U. Schiotz - the comparative history of western and Hawaiian mapping and views of space as they related to navigation.

[The Wayfinders: A Pacific Odyssey](#) - PBS's website on their video of the same name, with resources, "Ask the Expert" page, and more. You can also buy the video here.

Books:

- David Lewis's [*We the Navigators: the Ancient Art of Landfinding in the Pacific*](#) - the classic study of Pacific navigation.
- Stephen Thomas's [*The Last Navigator*](#) - very readable account of Stephen Thomas's (of PBS's *This Old House*) studies with great Pacific navigator Mau Piailug. Excellent.
- David Burch's [*Emergency Navigation*](#) - the methods and techniques of navigating by ocean swells, birds, weather, the stars and sun without instruments, and much more, are covered, as well as navigating with different combinations of tools missing.
- Ben R. Finney's [*Voyage of Rediscovery: A Cultural Odyssey through Polynesia*](#).

Videos:

- [*The Wayfinders: A Pacific Odyssey*](#)
- [*The Navigators*](#) - with Mau Piailug, the "Last Navigator."

NEW: a reader sent me this link for a beautiful wayfaring song: [Ke Ali'i o Kona i ka Lewa](#)
(Larry W. Jones 08/07/2003) (song#1859)

-
- [Home](#) • [Why Celestial Navigation?](#) • [History](#) • [Navigational Astronomy](#) • [The Theory](#) • [The Practice](#) • [Celnav in the Classroom](#) • [Vikings](#) • [Navigational Instruments](#) • [Wayfinding](#) • [Schools](#) • [Quotations](#) • [Resources](#) • [Dante](#) • [Other Links](#) • [Webmistress](#) •

Quotations



"Navigation is easy. If it wasn't, they wouldn't be able to teach it to Sailors."

From James Lawrence, fisherman under sail, Sailing Barge skipper and Sailmaker from Brightling Sea ,Essex, England.

**He had bought a large map representing the sea,
Without the least vestige of land:
And the crew were much pleased when they found it to be
A map they could all understand.**

**"What's the good of Mercator's North Poles and Equators,
Tropics, Zones, and Meridian Lines?"
So the Bellman would cry: and the crew would reply**

"They are merely conventional signs!"

Lewis Carroll, The Hunting of the Snark

The boundaries of our country, sir? Why sir, on the north we are bounded by the Aurora Borealis, on the east we are bounded by the rising sun, on the south we are bounded by the procession of the Equinoxes, and on the west by the Day of Judgment.

The American Joe Miller's Jest Book

Our state is shaken by innumerable storms, and there is only one hope for its future safety; just like a ship in the middle of the sea which the winds grasp, it now breaks up in the briny water. But if the brothers of Helen, shining stars, appear, good hope restores those downcast spirits.

Alciato's Book of Emblems, (pub. 1531) Emblem 43, "Spes Proxima" (Hope is Near)

Is this the greatest opening passage in literature or what?

"Call me Ishmael. Some years ago- never mind how long precisely- having little or no money in my purse, and nothing particular to interest me on shore, I thought I would sail about a little and see the watery part of the world. It is a way I have of driving off the spleen and regulating the circulation. Whenever I find myself growing grim about the mouth; whenever it is a damp, drizzly November in my soul; whenever I find myself involuntarily pausing before coffin warehouses, and bringing up the rear of every funeral I meet; and especially whenever my hypos get such an upper hand of me, that it requires a strong moral principle to prevent me from deliberately stepping into the street, and methodically knocking people's hats off- then, I account it high time to get to sea as soon as I can. This is my substitute for pistol and ball. With a philosophical flourish Cato throws himself upon his sword; I quietly take to the ship. There is nothing surprising in this. If they but knew it, almost

all men in their degree, some time or other, cherish very nearly the same feelings towards the ocean with me. "

Herman Melville, Moby Dick

Ahab to his Quadrant

Foolish toy! babies' plaything of haughty Admirals, and Commodores, and Captains; the world brags of thee, of thy cunning and might; but what after all canst thou do, but tell the poor, pitiful point, where thou thyself happenest to be on this wide planet and the hand that holds thee: no! not one jot more! Thou canst not tell where one drop of water or one grain of sand will be tomorrow noon; and yet with thy impotence thou insultest the sun! Science!

Herman Melville, Moby Dick

Sextant: an entertaining, albeit expensive, device, which, together with a good atlas, is of use in introducing the boatman to many interesting areas on the earth's surface which he and his craft are not within 1,000 nautical miles of.

Beard and McKie, Sailing: The Fine Art of Getting Wet and Becoming Ill While Slowly Going Nowhere at Great Expense

With the sextant he made obeisance to the sun-god, he consulted ancient tomes and tables of magic characters, muttered prayers in a strange tongue that sounded like *Indexerrorparallaxrefraction*, made cabalistic signs on paper, added and carried one, and then, on a piece of holy script called the Grail - I mean, the Chart - he placed his finger on a certain space conspicuous for its blankness and said, "Here we are." When we looked at the blank space and asked, "And where is that?" he answered in the cipher-code of the higher priesthood, "31 -15 - 47 north, 133 - 5 - 30 west." And we said, "Oh," and felt mighty small.

Jack London, The Cruise of the Snark

The difference between the sun's position and the position where the sun ought to be if it were a decent, self-respecting sun is called the Equation of Time.

Jack London, The Cruise of the Snark

The Snark sailed from Fiji on Saturday, June 6, and the next day, Sunday, on the wide ocean, out of sight of land, I proceeded to endeavour to find out my position by a chronometer sight for longitude and by a meridian sight for latitude. The chronometer sight was taken in the morning, when the sun was some 21 degrees above the horizon. I looked in the Nautical Almanac and found that on that very day, June 7, the sun was behind time 1 minute and 26 seconds, and that it was catching up at a rate of 14/67 seconds per hour. The chronometer said that at the precise moment of taking the sun's altitude it was 25 minutes after 8:00 in Greenwich. From this date it would seem a schoolboy's task to correct the Equation of Time. Unfortunately I was not a schoolboy.

Jack London, The Cruise of the Snark

Let me not to the marriage of true minds
 Admit impediments. Love is not love
 That alters when it alteration finds,
 Nor bends with the remover to remove.
Oh, no, it is an ever fixed mark
That looks on tempests and is never shaken.
It is the star to every wandering bark
Whose worth's unknown although its height be taken.
 Love's not Time's fool, though rosy lips and cheeks
 Within his bending sickle's compass come.
 Love alters not with his brief hours and weeks,
 But bears it out, even to the edge of doom.
 If this be error, and upon me proved,
 I never writ nor no man ever loved.

Shakespeare, Sonnet 116

Joseph Conrad on death...

...I observed his weary eyes gaze steadily ahead, as if there had been nothing between him and the straight line of the sea and sky, where whatever a seaman is looking for is first bound to appear. But I have also seen his eyes rest fondly upon the faces in the room, upon the pictures on the wall, upon all the familiar objects of that home, whose abiding and clear image must have flashed often on his memory in times of stress and anxiety at sea. Was he looking out for a strange Landfall, or taking with untroubled mind the bearings for his last Departure? It is hard to say; for in that voyage from which no man returns Landfall and Departure are instantaneous, merging together in one moment of supreme and final attention.

Joseph Conrad, The Mirror of the Sea

This one's on flight, but the same idea applies to those who only know electronic navigation....

One day the stars will be as familiar to each man as the landmarks, the curves, and the hills on the road that leads to his door, and one day this will be an airborne life. But by then men will have forgotten how to fly; they will be passengers on machines whose conductors are carefully promoted to a familiarity with labeled buttons, and in whose minds the knowledge the sky and the wind and the way of the weather will be as extraneous as passing fiction.

Beryl Markham, West with the Night

Why electronics will never be enough....

The new ship here is fitted according to the reported increase of knowledge among mankind. Namely, she is cumbered end to end, with bells and

trumpets and clock and wires, it has been told to me, can call voices out of the air of the waters to con the ship while her crew sleep. But sleep thou lightly. It has not yet been told to me that the Sea has ceased to be the Sea.

Rudyard Kipling

Here is John Milton writing on the obliquity of the earth's axis:

Some say, he bid his angels turn askance
The poles of earth twice ten degrees or more
From the sun's axle; they with labour push'd
Oblique the centric globe: some say, the sun
Was bid turn reins from th' equinoctial road
Like distant breadth to Taurus with the seven
Atlantic Sisters, and the Spartan Twins,
Up to the Tropic Crab; thence down amain
By Leo, and the Virgin, and the Scales,
As deep as Capricorn, to bring in change
Of seasons to each clime.

"Paradise Lost"

Charles Kingsley on the constellation Andromeda:

I set thee
High for a star in the heavens, a sign and hope for the seamen.

"Andromeda"

The wind has shifted; now it blows across
our path and rises from the black west, now
the air has thickened into mist. We cannot
hold out against it, cannot keep on course.
Since Fortune has the better of us now,
Let us obey and turn aside where she
has called. I think the faithful shores of Eryx,

your brother, and Sicilian ports are not
far off, if only I remember right
and can retrace the stars I watched before.

Virgil, The Aeneid, trans. by Allen Mandelbaum

St. Paul before his shipwreck:

But soon a tempestuous wind, called the northeaster, struck down from the land; and when the ship was caught and could not face the wind, we gave way to it and were driven....As we were violently storm-tossed, they began the next day to throw the cargo overboard; and the third day they cast out with their own hands the tackle of the ship. And when neither sun nor stars appeared for many a day, and no small tempest lay on us, all hope of our being saved was at last abandoned.

Acts of the Apostle, Ch. 27:14-20, Revised Standard Version

When I heard the learn'd astronomer,
When the proofs, the figures, were ranged in columns before me,
When I was shown the charts and diagrams, to add, divide, and measure them,
When I sitting heard the astronomer where he lectured with much applause in the lecture-room,
How soon unaccountable I became tired and sick,
Till rising and gliding out I wander'd off by myself,
In the mystical moist night-air, and from time to time,
Look'd up in perfect silence at the stars.

Walt Whitman

Kenneth Grahame asks the pertinent question:

" This has been a wonderful day!" said he, as the Rat shoved off and took to

the skulls again. "Do you know, I've never been in a boat before in all my life."

"What?" cried the Rat, open-mouthed. "Never been in a -- you never -- well I -- what have you been doing, then?"

The Wind in the Willows

"Is it so nice as all that?" asked the Mole shyly....

"Nice? It's the only thing," the Water Rat said solemnly, as he leant forward for his stroke. "Believe me, my young friend, there is nothing -- absolutely nothing -- half so much worth doing as simply messing about in boats. Simply messing," he went on dreamily: "messing -- about -- in -- boats."

The Wind in the Willows

Just had to throw these in because I have so many occasions to observe their truth!

"You ain't gonna learn what you don't want to know."

The Grateful Dead

"In the face of stupidity, the gods themselves are helpless."

Unknown, but my mother quoted it often!

New quotes always welcome and actively solicited! E mail the [webmistress!](#)

[Home](#) • [Why Celestial Navigation?](#) • [History](#) • [Navigational Astronomy](#)
[The Theory](#) • [The Practice](#) • [Celnav in the Classroom](#) • [Vikings](#)
[Navigational Instruments](#) • [Wayfinding](#) • [Quotations](#) • [Resources](#) • [Dante](#) •
[Other Links](#) • [Schools](#) • [Webmistress](#) •

SCHOOLS

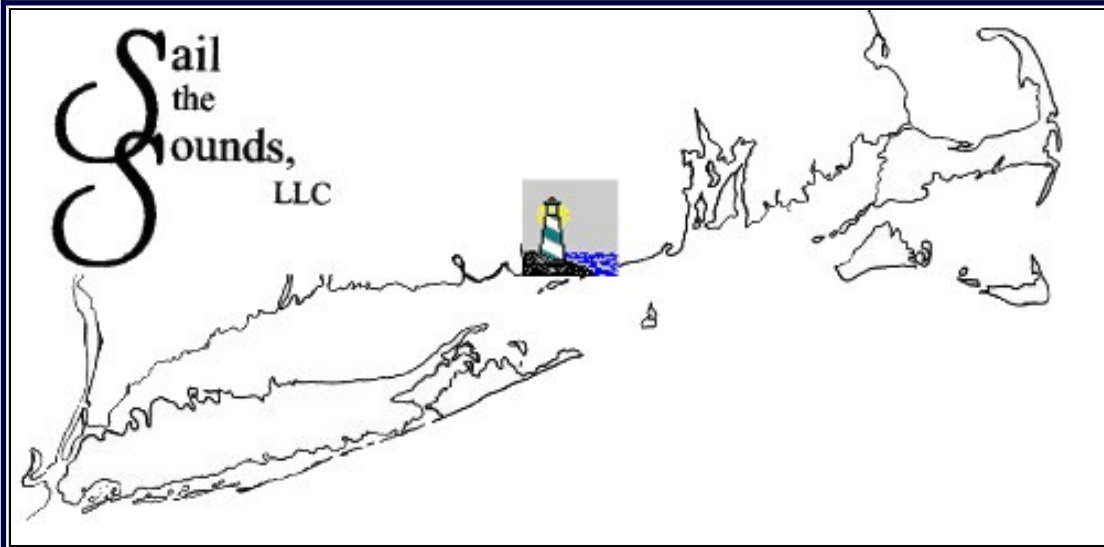

If you are in or near Connecticut, check out Sail the Sounds for a two-day ashore, one-day aboard Celestial Navigation course. My son got certified in Coastal Nav from here, and they're awesome!



Starpath has a terrific home study course, which I highly recommend (I took it myself). You get email and phone help from an extremely helpful staff. **PLUS THEY HAVE A NEW ONLINE COURSE!**

Ocean Navigator
 School of Seamanship

The Ocean Navigator magazine folks bring you seminars given in Maine and other locations around the country.



SCHOOL of OCEAN SAILING

Liveaboard courses on the Saman, a 52-foot ketch, in the Gulf of Maine and the Caribbean. I haven't been on one but they have received rave reviews --- I'd love to go!



Welcome to Mystic Seaport

The Planetarium at Mystic Seaport in Connecticut has ten-week on-site courses as well as one-day sun shooting classes. They also sell a great book---- Susan Howell's (see my [Practice](#) page), which you can work through yourself at home.

Disclaimer: I get no money or anything else from these schools - I list them because I like them, and I'm the boss of my webpage!

• [Home](#) • [Why Celestial Navigation?](#) • [History](#) • [Navigational Astronomy](#) • [The Theory](#) • [The Practice](#) • [Celnav in the Classroom](#) • [Vikings](#) • [Navigational Instruments](#) • [Wayfinding](#) • [Quotations](#) • [Resources](#) • [Dante](#) • [Other Links](#) • [Webmistress](#) •

RESOURCES



This page lists all the resources that are discussed on the other pages of the Celestial Navigation Net website.

SCHOOLS

[The School of Ocean Sailing](#) - onboard in Maine

[Starpath School of Navigation](#) - correspondence and onsite in Seattle. **ALSO NEW ONLINE COURSE**

[Mystic Seaport Planetarium Courses](#) - onsite in Connecticut

[Ocean Navigator School of Seamanship](#) - seminars in various locations

[Windward Sailing School](#) - ASA certification in celestial navigation off Amelia Island, Florida

[Sail the Sounds](#) - onsite in Connecticut

PRODUCTS

[Starpath](#)

[Celestaire](#)

[Landfall Navigation](#)

[Land and Sea Collection](#)

NAVIGATIONAL HISTORY AND INSTRUMENTS *(See also Classroom Links)*

[John Harrison and the Longitude Problem](#)

[Medieval Scientific Instruments](#) ([kamal](#), [cross-staff](#), and [quadrant](#))

[Hands-On Astrolabe Page](#)

[Keith Powell's Awesome Java Astrolabe](#)

[Chaucer's Treatise on the Astrolabe](#)

[www.astrolabes.org](#)

[A Short History of Sight Reduction](#)

[Seaman's Secrets](#) - 1595

[History of the Sextant](#)

[Scientific Instruments of Medieval and Renaissance Europe](#)

[Longitude at Sea, from the Galileo Project](#)

[African Star Lore](#)
[How A Sextant Works](#)
[Navigation by Sextant](#)

WAYFINDING

[Traditional Navigation in the Western Pacific](#)
[Pacific Voyaging Society](#)
[Wayfinding, or Noninstrument Navigation](#) from the PVS
[Navigation in the Information Age: History and Context](#) from Hawaii Nation.
[Aboriginal \(Native American\) Astronomy](#)

Videos

- [The Wayfinders: A Pacific Odyssey](#)
- [The Navigators](#)

CLASSROOM LINKS

Math and Science

[Navigational Trigonometry](#)
[Astronomy Online](#) Polaris project
[Eyes on the Sky, Feet on the Ground](#) - From the Smithsonian Astrophysical Observatory - Children's Astronomy Activities. See their [Chapter](#) on Coordinate Systems and Celestial Mapping
[Heavenly Mathematics: Highlights of Cultural Astronomy](#)
[Astronomy without a Telescope](#)
[Navigating Around the World by Observing the Sun](#)
[Nova's Shockwave Game on Finding Your Latitude](#)

Projects

- [How to Make a Quadrant](#)
- [How to Use a Quadrant](#)
- [Other Projects with Quadrants](#)
- [Measuring North Latitude at Night](#)
- [How to Use a Cross-Staff](#)

- [Make your own planisphere](#)
- [Build Your Own Sextant](#)
- [Cardboard Sextant Kit](#) - also [here](#) and [here](#)

History (See also Navigational Instruments and History, above)

[Pre-1400 navigation](#)

Age of Exploration

[Christopher Columbus Navigation Page](#), with a [Celestial Navigation](#) page.

[Discovers' Web](#)

[The Age of Exploration](#) from the Mariner's Museum

[Determination of Latitude by Sir Francis Drake](#) - a page by Bob Graham.

[Teacher's Guide to Teaching Longitude](#) _

[Navigation During the Time of Columbus](#)

[Secrets of Ancient Navigation](#)

[Latitude: The Art and Science of 15th and 16th Century Navigation](#)

[How Columbus and Apollo Astronauts Navigated](#)

American History

[The Bowditch Initiative Website](#)

[Short Biography of Nathaniel Bowditch](#)

[The Underground Railroad: Connections to Freedom and Science](#) _ slaves used celestial navigation to find their way north.

[Institute of Navigation's Spring 2000 Newsletter](#) -scroll 1/2 down to Portney's Corner for Lewis and Clark celestial navigation article.

[www.lewis-clark.org](#). - Articles on [Formal Navigation by Lewis and Clark](#), [Course, Time and Distance](#), and [Latitude and Longitude](#)

[David Thompson and Land Navigation](#) (also Western Canada)

The Vikings

[Viking Navigation](#)

[Viking Navigation and Astronomy](#)

[Viking Navigation](#)

[The Legend of the Viking Sunstone](#)

[Viking Sun Compass](#)

TUTORIALS AND SUMMARIES

[Umland's Short Guide to Celestial Navigation](#)

[Al Placette's Page](#)

[Omar Reis's Introduction to Celestial Navigation](#)

[Celestial Navigation Simplified, Parts I and II](#)

[Bill Myers One Page intro](#)

[Douglas S. J. De Couto's summary](#)

[Celestial Navigation Basics from John Jacq](#)

[Powerpoint Navigation Slide Shows from Purdue's Naval ROTC](#) (scroll down)

[Penn State's Naval ROTC](#) - Powerpoint slide show (Lessons 15-19)

[Ed Falk's Sample Leg for the Silicon Sea Series](#)

[Celestial Navigation for Dummies](#)

ONLINE DATA: Almanac Information, Lat-Lon Finders, etc.

[Bowditch's American Practical Navigator Online](#)

[Almanac and Sight reduction Information from the US Navy](#)

[Find your latitude and longitude at ETAK](#)

[Publications 229 and 249](#) - Naval Almanac and Air Almanac at NIMA

[Universal Time from the US Navy](#)

[Omar Reis's Online Nautical Almanac](#)

[Civil and Nautical Twilight, Sun and Moon Rise and Set](#)

INSTITUTES AND FOUNDATIONS

[The Foundation for the Promotion of the Art of Navigation](#)

[Royal Institute of Navigation](#)

[Institute of Navigation](#)

[Nautical Almanac Office](#)

MISCELLANEOUS SITES

[US Sailing's Requirements for Celestial Navigation Certification](#)- the governing body for the sport of sailing in the US.

[The U.S. Navy's Celestial Navigation Page](#)

[Ocean Navigator Magazine](#)

[The Navigation List](#) - archives

[The Navigation List](#) - webpage

[Interactive Sextant](#)

SOFTWARE AND JAVA PROGRAMS

[H. Umland's Freeware Page](#)

[Palm Pilot Celnav Program](#)

[Java Script Programs for Navigators by Jacky Wong](#)

[Omar Reis's Navigation Star Finder](#)

[Omar Reis's Navigator Light Computer Program](#)

[Walter Fendt's Apparent Position of a Star](#)

[Walter Fendt's Coordinate Graphic Java Page](#)

[The Electric Astrolabe](#)

[ASNAv and DeltaWin](#)

[Pocket Stars PC](#)

[AstroNav PC and Compact Data](#)

BOOKS

- [Secrets of the Viking Navigators](#)
- [Latitude Hooks and Azimuth Rings](#), by Dennis Fisher
- [The Stars: A New Way to See Them](#) by H.A. Rey
- [Longitude: The True Story of a Lone Genius Who Solved the Greatest Scientific Problem of His Time](#) by Dava Sobel
- [Navigation in the Age of Discovery](#), By Duane A. Cline
- [Taking the Stars: Celestial Navigation from Argonauts to Astronauts](#) by Peter Ifland
- [Emergency Navigation](#) by David Burch
- [The Discarded Image](#) by C.S. Lewis (the Ptolemaic model of the universe)
- [Carry On, Mr. Bowditch](#), by Jean Lee Latham
- [Adrift](#), by Steve Callahan
- [My Old Man and the Sea](#), David and Daniel Hayes.
- [Celestial Navigation for Yachstmen](#) by Mary Blewitt
- [Practical Celestial Navigation](#) by Susan Howell
- [We the Navigators: the Ancient Art of Landfinding in the Pacific](#) by David Lewis
- [The Last Navigator](#) by Stephen Thomas
- [Voyage of Rediscovery: A Cultural Odyssey through Polynesia](#) by Ben. R. Finney
- [The Sextant Handbook](#) by Bruce Bauer
- [The Star-Finder Book: A Complete Guide to the Many Uses of the 2102-D Starfinder](#) by David Burch
- [The Nautical Almanac, Commercial Edition](#)
- [Long-Term Almanac 2000-2050](#) by Geoffrey Kolbe
- [Line of Position Navigation: Sumner and Saint Hilaire - the Two Pillars of Modern Celestial Navigation](#) by Peter Ifland and Michel Vanvaerenbergh

Out of Print - Worth Looking For!

- *Airborne: A Sentimental Journey* by William F. Buckley Jr.
- *The Haven Finding Art: A History of Navigation from Odysseus to Captain Cook*, by E.G.R. Taylor
- *A History of Nautical Astronomy* by Charles H. Cotter

-
- [Home](#) • [Why Celestial Navigation?](#) • [History](#) • [Navigational Astronomy](#) • [The Theory](#) • [The Practice](#) • [Celnav in the Classroom](#) • [Vikings](#) • [Navigational Instruments](#) • [Wayfinding](#) • [Schools](#) • [Quotations](#) • [Resources](#) • [Dante](#) • [Other Links](#) • [Webmistress](#) •

Other Links of Interest

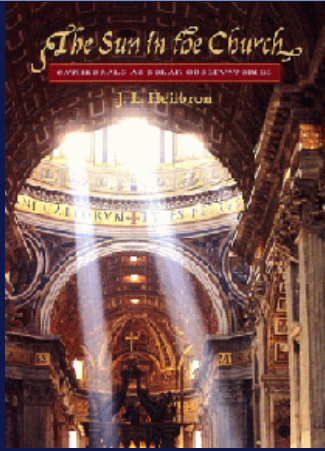

As a college teacher I liked to remind my students of the title of a comedy album by the Firesign Theater: "Everything You Know is Wrong." It does, in fact, turn out that lots of things that "everybody knows" happen to be false, such as that any educated person back 2 1/2 millennia ever believed the world is flat. Another is the anti-science rap the Catholic Church has gotten ever since Andrew White (a former president of Cornell) published his anti-Catholic screed, "A History of the Warfare of Science with Theology in Christendom," still being quoted on some web pages as legitimate scholarly history. J.L. Heilbron, a science historian, has written [The Sun in the Church: Cathedrals as Solar Observatories](#), published by Harvard University Press, which goes a long way toward setting the record straight.. "Centuries of oversimplifications have concealed just how hard Rome worked to amass astronomical tools, measurements, tests and lore. In its scientific zeal, the church adapted cathedrals across Europe, and a tower at the Vatican itself, so their darkened vaults could serve as solar observatories. Beams of sunlight that fell past religious art and marble columns not only inspired the faithful but provided astronomers with information about the Sun, the Earth and their celestial relationship." So says William Broad in the New York Times - read more [here](#). No one interested in the history of astronomy should miss this - thanks to Helmer Askalsen for pointing me to it!



Helmer Askalsen at the University of Singapore has a unique site on one of my beloved passions - cultural astronomy. Calendars, the Equation of Time, Archaeoastronomy, astronomy in culture and nature, sundials, moondials, mathematics, navigation, cartography, Stonehenge, the Egyptians --- there are more links and content here than are dreamt of in your philosophy! A truly wonderful find.

[Heavenly Mathematics: Highlights of Cultural Astronomy](#)

Solar eclipse at the meridian line at S. Maria degli Angeli in Rome

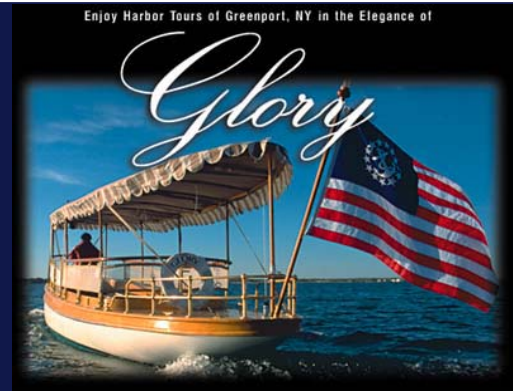
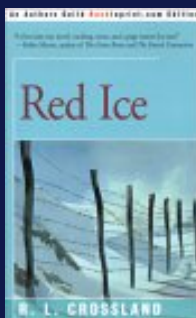

R. L. Crossland's novel is not about celestial navigation (although it *is* mentioned!). It is a thriller about a daring rescue attempt in the Siberia of the Stalinist gulag - a kind of *Saving Private Ryan* for the Cold War era, while ranging in space and time from Viet Nam to Algeria to the Sea of Japan. Most of these kinds of books are written by writers who do tremendous research, but admit that all their knowledge is book-learning. Crossland is a retired Navy Seal officer, diver, parachutist, etc., so the story has an immediacy that comes from experience. It is also singularly intelligent, but even if you don't catch the classical references, the book will still captivate you.

Do you do the celestial navigation problems in the back of *Ocean Navigator* magazine? Ever wish you had that kind of knowledge and expertise? Well, now you can meet the author and go *mano a mano!*

The author of those problems, David Berson, runs an awesome excursion boat for harbor tours and private charters -- the electric power *Glory* -- out of Greenport , New York, on Long Island Sound. No diesel fumes, and imagine the peace and quiet! He has also captained, at various times, such famous ships as the *Harvey Gamage* and the *Ocean Star*.

Check out his website at www.greenportlaunch.com.



A TRULY worthy cause. Go to the website and read for yourself.



Summer English language courses for adults and families from around the world on an island off the coast of Maine. A wonderful place for sailing, and you can see every star in the sky! If any of my international readers have a friend or family member who wants to learn English, I guarantee you cannot do better than the Acadia Center!

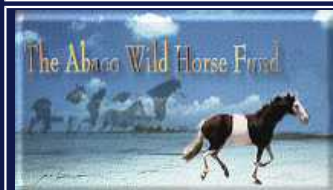

The seventeen remaining wild horses on Abaco Island are all named for navigational stars. They are almost certainly the direct descendents of the first horses introduced into the New World. Click [here](#) for more information and how you can help.

Disclaimer - no one pays your webmistress for these links! They are here because I like them!

- [Home](#) • [Why Celestial Navigation?](#) • [History](#) • [Navigational Astronomy](#) • [The Theory](#) • [The Practice](#) • [Celnav in the Classroom](#) • [Vikings](#) • [Navigational Instruments](#) • [Wayfinding](#) • [Quotations](#) • [Resources](#) • [Dante](#) • [Other Links](#) • [Schools](#) • [Webmistress](#) •

WE B M I S T R E S S



Your webmistress uses that term, rather than webperson or webmaster, with the same ironic stance taken by some of the new generation of young women, who have taken back the sometimes condescending (when used by adults of other adults) "girls," and proudly call themselves "grrrls." She likes the term because it has 21st century connotations and medieval-renaissance connotations.

Your webmistress has graduate degrees in philosophy (all-but-dissertation) as well as literature and theology from Yale. She believes a bad day on the water is better than a great day on land, and doesn't get to sail anywhere near as much as she'd like. Her favorite star is Fomalhaut, but she is also partial to Aldebaran, the eye of the constellation Taurus, and named her classic Bull's-Eye (get it?) sloop (just 15'8", hull designed by Herreshoff) after it. She believes that one of the most beautiful things the eye can behold is the line where the ocean meets the sky.

Your webmistress welcomes submissions, new links, quotations, corrections, notifications of broken links, whatever. [Write to her.](#)

- [Home](#) • [Why Celestial Navigation?](#) • [History](#) • [Navigational Astronomy](#) • [The Theory](#) • [The Practice](#) • [Celnav in the Classroom](#) • [Vikings](#) • [Navigational Instruments](#) • [Wayfinding](#) • [Schools](#) • [Quotations](#) • [Resources](#) • [Dante](#) • [Other Links](#) • [Webmistress](#) •

C O N T A C T

This was formerly a direct mail link - all you had to do was click on "Contact" and a mail window would open. However, various web robots look for "a href:mailto" hyperlinks in web page source codes., and I am now receiving tons of junk email - a truly unbelievable amount - and I can't filter it all out.

Therefore, I have removed the link. If you want to contact me, please email

cantxxxiii at yahoo.com.

You will have to type the address in yourself with the @ sign.

[back](#)

DANTE



Dante, the Italian author of *The Divine Comedy*, lived in the late 13th and early 14th centuries, and is, to my mind, the world's greatest poet. "Shakespeare and Dante divide the modern world between them;" T.S. Eliot said. "There is no third."

I have Dante to thank for my love of celestial navigation. The entire *Comedy*, his greatest poem (so great that we know it as *The Divine Comedy*), is full of images of ships, navigation, sailing, and stars (for example, the quote on the home page). The *Purgatorio* begins,

"To course over better waters the little boat of my genius now raises her sails..."

and the *Paradiso* reminds the reader that not everyone can commit themselves to the open ocean - those of us who are following only in "little barks" would do well to turn back to the shore, as the muses point Dante to Ursa Major and Ursa Minor. All three books end with the word "stars;" one of the most famous last lines in literature is the end of the *Paradiso*:

"My will and desire were revolved, as a wheel that is equally turned, by the Love which moves the sun and other stars."

In a class I once took on Dante, when we came upon the celestial image of the sun rising at a point which joins "four circles with three crosses," the professor suggested that we skip over "all the astronomy stuff." I knew next to nothing about astronomy but wanted to understand this image, which turned out to be the Vernal Equinox - the four circles were the ecliptic, the celestial equator, the celestial horizon, and the equinoctial colure (Great Circle passing through the two celestial poles and the two equinoctial points). After that I was hooked on astronomy, and since I already loved

sailing, it was a marriage made in heaven.

Dante's earliest famous work is the Vita Nuova, the new life, which describes how as a young man he first laid eyes upon a young Florentine girl, Beatrice. After her death, he swore he would write no more of her until he could write something truly worthy, and he kept his promise. Though he wrote poetry and prose all his life, he did not write of Beatrice again until The Divine Comedy. It was written in exile from his beloved Florence, and finished two months before he died. In it Beatrice is referred to as the "Pole Star" of his life. The lesser critics believe there never was a Beatrice, that she is an allegorical representation only. There is no way, they believe, that the mere salutation of the girl could have so radically changed and influenced Dante's life so. They have never experienced such a phenomenon --- more's the pity.

I prefer Dante in the Italian, in John Singleton's version with a prose translation on the facing page. Unlike some Dante scholars, I recommend that people new to Dante read the John Ciardi translation of the Comedy. It includes notes for each chapter that are good when they are on history and not so good when they are on theology, but at least they are right there, and the translation is eminently accessible. The [Digital Dante project](#) has an online version of the Comedy with [parallel translations](#) by Mandelbaum and Longfellow to the Italian.

I would like to thank my virtual friend Helmer Askalsen for pointing me to "[Celestial Themes in Art and Architecture](#)" at Dartmouth. There are some beautiful pictures (Giovanni di Paolo's and Gustave Dore's) at this site, arranged in order of the model of the universe as it was imagined in Dante's time - the nine spheres of the heavens in the Paradiso.



- [Home](#) • [Why Celestial Navigation?](#) • [History](#) • [Navigational Astronomy](#) • [The Theory](#) • [The Practice](#) • [Celnav in the Classroom](#) • [Vikings](#) • [Navigational Instruments](#) • [Wayfinding](#) • [Schools](#) • [Quotations](#) • [Resources](#) • [Dante](#) • [Other Links](#) • [Webmistress](#) •

Marion to Bermuda

C r u i s i n g Y a c h t R a c e



[ENTER SITE](#) ▶

Land and Sea Collection

[Home](#)

[NEW SEXTANTS](#)

[USED - PREOWNED SEXTANTS](#)

[C. PLATH CLASSIC](#)

[C. PLATH ALUMINIUM SEXTANT](#)

[C. PLATH SEXTANT COLLECTOR QUALITY](#)

[SHIPBUILDERS PLATES](#)

[SHIPS CANNON - 18th CENTURY](#)

[SHIPS CLOCKS](#)

[RADIO ROOM CLOCKS - SOLAS](#)

[ABOUT OUR MODELS](#)

[STEAM, MOTORSHIP & WARSHIP MODELS](#)

[USS ARIZONA BB 39](#)

[CLASSIC MOTOR YACHT](#)

[GARWOOD SPEEDSTER](#)

[PT 109 MODEL](#)

[TRAWLERS - WORK BOATS](#)

[T.S.S. NORMANDIE](#)

[U.S. DESIGN MODELS](#)

[SAILBOAT DIMENSIONS](#)

[CATBOAT MODEL](#)



Is the source for fine quality ship and aircraft models, vintage ships clocks, polished brass

nautica, shipbuilders plates, marine antiques, and is the largest seller of used and pre-owned marine sextants on the internet.



You are visiting the home page of the Land and Sea Collection where you will find a collection of the finest marine antiques, shipbuilders plates, nautica, ship and aircraft models, and the largest re-seller of

AUTHENTIC SHIPBUILDER'S PLATES



OF DISTINCTION

SCHOONER BLUENOSE - MEDIUM SIZE

[AMERICA SCHOONER
MODEL](#)

[ATLANTIC SCHOONER](#)

[BLUENOSE SCHOONER
MODELS](#)

[WAWONA SCHOONER
MODEL](#)

[SKIPJACK MODEL](#)

[S&S DORADE MODEL](#)

[S & S YAWL ODYSSEY](#)

[HERRESHOFF 12.5](#)

[FRIENDSHIP SLOOP](#)

[J CLASS RAINBOW](#)

[TALL SHIP MODELS](#)

[VINTAGE AIRPLANE
MODELS](#)

[MARINE and NAUTICAL
ANTIQUES](#)

[SHIPS LIGHTING](#)

[PAY HERE - VIEW CART -](#)

[LINKS](#)

previously owned sextants in the U.S.

We have both a Maritime and Aviation Industry background which enables us to search out hard-to-find items of an unusual nature which we make available at fair and honest prices backed by our reputation for fair dealing. As collectors of fine arts, antiques, ship, boat and plane models we have an eye for beauty and value, and enjoy passing our knowledge on to our customers.

Some of our memberships include the: Association of Naval Aviation, Silver Wings, The Tailhook Association, Naval Academy Sailing Squadron, McCampbell's Aces Squadron, and the Naval Order of the United States.



NEWLY LAUNCHED - SEE DETAILS

INTERNATIONAL BUYERS WELCOME.

We have customers in Australia, Austria, Belgium, Canada, Chile, England, France, Germany, Holland, Ireland, Italy, Kuwait, Mexico, Saudi Arabia, Spain, USVI and the Eastern Caribbean.

The list is growing weekly. Email us for details because there are some extra processing costs in sending interantional shipments.

OUR UNCONDITIONAL GUARANTEE

OUR UNCONDITIONAL GUARANTEE: For products other than sextants*, if not completely satisfied with your purchase it may be returned, if without damage, within five days of receipt in its original condidtion and packaging. Return items must be insured for their full value. A prior email authorization by us for the return is required. Unfortunately, no refund can be made for the cost of shipping, packaging and handling.

* Please see guarantee under new, and previously owned sextants which

varies between the two and our other products.

We sell high quality products, at fair and honest prices, and back them by old fashioned customer service. That's not a catchy slogan, its a fact.

Please email us at info@landandseacollection.com for information, detailed descriptions and prices.

LAND AND SEA COLLECTION
One Avenue A
FORT PIERCE, FLORIDA, USA

Copyright 2004, 2003 by Land and Sea Collection, All Rights Reserved

CLICK HERE NOT TO MISS OUR COMPANION SITE!.....
Oriental Arts Group

3781

Since 18 JAN 2004



CATALOG

SOFTWARE

COURSES

ACCESSORIES

BOOKS



CELESTIAL NAVIGATION COASTAL NAVIGATION EMERGENCY NAVIGATION NAVIGATION RULES
RADAR MARINE WEATHER RESOURCES DOWNLOADS SUPPORT

**NEWSLETTER
 CALENDAR
 SITE MAP
 CONTACT
 ABOUT**

See **NEWSLETTER** for special offers available...



Welcome to Starpath School of Navigation. We offer training and related products in all phases of marine navigation and weather. The [About] link describes the school, the orange Help [?] and Info [i] links explain how to use this website.



Online Courses Now Available!

Starpath now offers a wide variety of online courses and resources. The serial number from your past or present Starpath purchase provides you with a WebCard which in turn grants access to the Online Classroom.



Celestial Navigation Section

For navigation out of sight of land—using timed sextant sights of the sun, moon, stars, and planets—we offer classroom and home study courses, star maps and star finders, books, tips, articles, sextants, and Internet links. We have many years and thousands of miles of experience actually doing this, as well as teaching others how to do it.



Inland and Coastal Navigation Section

For navigation in sight of land—or in the fog, power or sail, in large or small vessels—we offer classroom and home study courses, plus the required tools and books. We've also collected an extensive set of internet links to marine navigation resources on the net.



Radar Section

This is the home website of the Starpath Radar Trainer software and related textbooks on practical application of marine radar. You will also find tips on combining radar with GPS and depth sounder for safe, efficient navigation.



Marine Weather Section

Preview our Starpath Weather Trainer software, home study courses, and classroom courses, designed to teach mariners how to interpret and apply available weather data. Explore our convenient links to marine weather data and new section on how to read weather maps.



Navigation Rules Section

Tips on the best way to learn the Rules plus all the resources you need to do it — books and software, and internet links to admiralty law, CFRs, USCG marine safety office, and other legal matters. Plus *free download* of the International, US Inland, and Canadian Navigation Rules.



Emergency Navigation Section

You can learn all the best ways to navigate with limited instruments, or none at all. Read about David Burch's text on Emergency Navigation. You'll also find information on the novel and useful Emergency Navigation Card and planetarium classes on steering by the stars.

[About Starpath](#) | [Online Catalog](#) | [Study Online](#) | [Site Map](#) | [Tech Support](#)

Copyright © 1996-2003
Starpath Corporation
designed and hosted by



[E-mail Starpath](#)

Requires a onetime-only anti-spam confirmation.



amazon.com



VIEW CART

WISH LIST

YOUR ACCOUNT

HELP

WELCOME

YOUR STORE

BOOKS

APPAREL & ACCESSORIES

ELECTRONICS

TOYS & GAMES

MUSIC

CELL PHONES & SERVICE



SEE MORE STORES

Search

Browse Subjects

Bestsellers

Magazines

Corporate Accounts

e-books & docs

New & Used Textbooks

Used Books

Search:

Browse:

You clicked on this item...

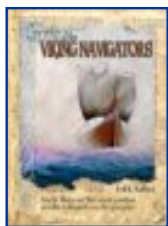

Secrets of the Viking Navigators

by Leif K. Karlsen

Average Customer Review: ★★★★★

Usually ships in 2 to 3 weeks

Price: \$20.00

6 used & new from \$19.00



Eligible for FREE Super Saver Shipping on orders over \$25. See details.

Or buy used: \$19.00

David Burch, Ph.D. Director, Starpath School of Navigation, Seattle, WA

Most navigators have heard of Viking sunstones; few realize they are more than legend. Karlsen has brought them to life.

You may also be interested in these items...

Show items from:

All Products

Books (4)



Line of Position Navigation

by Michel Vanvaerenbergh

More like this



Latitude Hooks and Azimuth Rings

by Dennis Fisher

More like this



The Complete On-Board Celestial Navigator

by George C. Bennett

More like this



Taking the Stars

by Peter Ifland

More like this

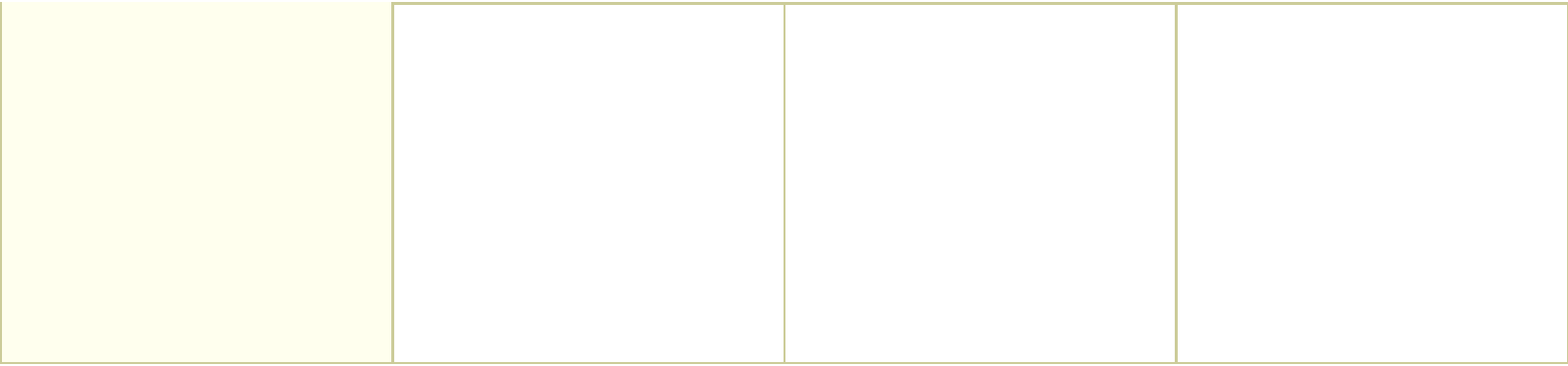

New at Amazon.com

Visit our new [Seasonal Tableware Store](#) and save up to 40% on Lenox, Spode, and more.

\$25 Off Tools & Hardware

\$25 Offer

Take \$25 off when you spend \$199 or more on [Tools & Hardware](#) products offered by Amazon.com. [Here's how](#) (restrictions apply).

New at Amazon.com



REPLACEMENTS, LTD.

Find more than 600,000 china, crystal, and silver products in the [Replacements, Ltd. Store](#).

Where's My Stuff?

- Track your [recent orders](#).
- View or change your orders in [Your Account](#).

Shipping & Returns

- See our [shipping rates & policies](#).
- [Return](#) an item (here's our [Returns Policy](#)).

Need Help?

- Forgot your password? [Click here](#).
- [Redeem](#) or [buy](#) a gift certificate.
- [Visit our Help department](#).

Search

for

Your Recent History

[Learn More](#)

Recently Viewed Products

- [The Sextant Handbook](#) by Bruce Bauer
- [Taking the Stars](#) by Peter Ifland
- [Navigation in the Age of Discovery](#) by Duane A. Cline
- [Carry On, Mr. Bowditch](#) by Jean Lee Latham, John O'Hara Cosgrave
- [My Old Man and the Sea](#) by David Hays

Customers who bought items in your Recent History also bought:

- [Celestial Navigation for Yachtsmen](#) by Mary Blewitt
- [Celestial Navigation in a Nutshell](#) by Hewitt Schlereth

▶ [Visit the Page You Made](#)

Turn your past books purchases into \$\$\$
[Learn more](#) about selling at Amazon.com today!

[Top of Page](#)

[Books Search](#) | [Browse Subjects](#) | [Bestsellers](#) | [Magazines](#) | [Corporate Accounts](#)
[e-Books & Docs](#) | [Bargain Books](#) | [Used Books](#)

[Amazon.com Home](#) | [Directory of All Stores](#)

Our International Sites: [Canada](#) | [United Kingdom](#) | [Germany](#) | [Japan](#) | [France](#)

[Contact Us](#) | [Help](#) | [Shopping Cart](#) | [Your Account](#) | [Sell Items](#) | [1-Click Settings](#)

[Investor Relations](#) | [Press Releases](#) | [Join Our Staff](#)

[Conditions of Use](#) | [Privacy Notice](#) © 1996-2004, Amazon.com, Inc. or its affiliates



amazon.com.



VIEW CART | WISH LIST | YOUR ACCOUNT | HELP

WELCOME

YOUR STORE

BOOKS

APPAREL & ACCESSORIES

ELECTRONICS

TOYS & GAMES

MUSIC

CELL PHONES & SERVICE

SEE MORE STORES

Search

Browse Subjects

Bestsellers

Magazines

Corporate Accounts

e-books & docs

New & Used Textbooks

Used Books

Search:

Browse:

You clicked on this item...



Line of Position Navigation

by Michel Vanvaerenbergh

Usually ships in 24 hours

Price: **\$13.99**



Eligible for **FREE Super Saver Shipping** on orders over \$25. [See details.](#)

You may also be interested in these items...

Show items from:

▶ **All Products**
[Books](#) (6)

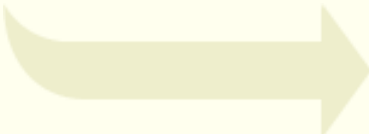

Secrets of the Viking Navigators

by Leif K. Karlsen

More like this



Mercator

by Nicholas Crane

More like this



The Complete On-Board Celestial Navigator

by George C. Bennett

More like this



Emergency Navigation

by David Burch

More like this



Latitude Hooks and Azimuth Rings

by Dennis Fisher

More like this



Taking the Stars

by Peter Ifland

More like this

New at Amazon.com

Visit our new [Seasonal Tableware Store](#) and save up to 40% on Lenox, Spode, and more.

\$25 Off Tools & Hardware

\$25 Offer

Take \$25 off when you spend \$199 or more on [Tools & Hardware](#) products offered by Amazon.com. [Here's how](#) (restrictions apply).

New at Amazon.com



REPLACEMENTS.LTD.

Find more than 600,000 china, crystal, and silver products in the [Replacements, Ltd. Store](#).

Where's My Stuff?

- Track your [recent orders](#).
- View or change your orders in [Your Account](#).

Shipping & Returns

- See our [shipping rates & policies](#).
- [Return](#) an item (here's our [Returns Policy](#)).

Need Help?

- Forgot your password? [Click here](#).
- [Redeem](#) or [buy](#) a gift certificate.
- [Visit our Help department](#).

Search

for

Your Recent History

[Learn More](#)

Recently Viewed Products

- [Secrets of the Viking Navigators](#) by Leif K. Karlsen
- [The Sextant Handbook](#) by Bruce Bauer
- [Taking the Stars](#) by Peter Ifland
- [Navigation in the Age of Discovery](#) by Duane A. Cline
- [Carry On, Mr. Bowditch](#) by Jean Lee Latham, John O'Hara Cosgrave

Customers who bought items in your Recent History also bought:



[Celestial Navigation for Yachtsmen](#) by Mary Blewitt



[Celestial Navigation in a Nutshell](#) by Hewitt Schlereth

[Visit the Page You Made](#)

Turn your past books purchases into \$\$\$
[Learn more](#) about selling at Amazon.com today!

[Top of Page](#)

[Books Search](#) | [Browse Subjects](#) | [Bestsellers](#) | [Magazines](#) | [Corporate Accounts](#)
[e-Books & Docs](#) | [Bargain Books](#) | [Used Books](#)

[Amazon.com Home](#) | [Directory of All Stores](#)

Our International Sites: [Canada](#) | [United Kingdom](#) | [Germany](#) | [Japan](#) | [France](#)

[Contact Us](#) | [Help](#) | [Shopping Cart](#) | [Your Account](#) | [Sell Items](#) | [1-Click Settings](#)

[Investor Relations](#) | [Press Releases](#) | [Join Our Staff](#)

[Conditions of Use](#) | [Privacy Notice](#) © 1996-2004, Amazon.com, Inc. or its affiliates



Mobile
Geographics

[CelestNav](#)
[MapTap](#)
[IQ Booster](#)
[Nautical](#)
[PalmOS](#)
[Links](#)
[Buy](#)

CelestNav™ for PalmOS

- [Buy it now](#)
- [Download the free, fully-functional demo today!](#)
- Look at the [online tutorial and instructions](#)
- [Join the CelestNav™ Users Email List](#)
- [Frequently asked questions about CelestNav](#)
- [Read these customer comments](#)

[Mobile Geographics home](#)



CelestNav™ turns your PalmOS handheld into a full-featured calculator for celestial navigation.

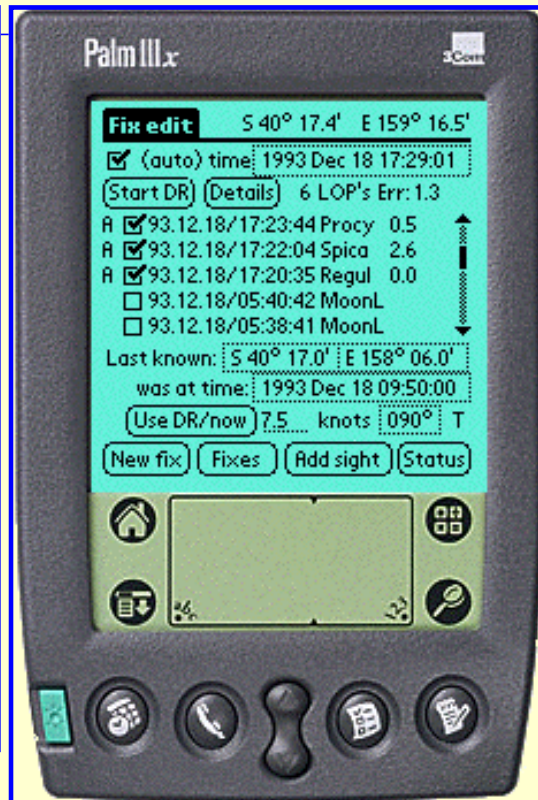

CelestNav™ requires 204k of free memory, and runs on all PalmOS compatible systems version 3.0 and above, including Handspring Visors, Sony Clies, and Handera and TRG units. The free math library [Mathlib](#), written by Rick Huebner, is required; a copy is included for your convenience.

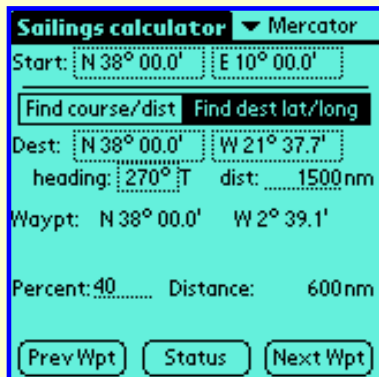

Try it:

Download a free, fully functional, 10-day demo of CelestNav™. Current version is 2.5, released October 12, 2002.

If you are already a CelestNav™ customer, this is also the file to download for your free version update.

- CelestNav™ 2.5 for PalmOS, [MacOS archive \(StuffIt format\)](#) for installation on your handheld (388 k)
- CelestNav™ 2.5 for PalmOS, [Windows archive \(ZIP file\)](#) for installation on your handheld (400 k)
- CelestNav™ for PalmOS, [native PalmOS format \(.PRC\)](#) for direct download to your handheld
- beta version of the next release, CelestNav™ for PalmOS, [native PalmOS format \(.PRC\)](#). Updated 25 Feb 2004. Do not use 3.0beta for navigation.

Tutorial

[Here's an online copy of the CelestNav™ tutorial.](#)

Buy it:

\$49.95. Version 1 customers receive version 2 as a free upgrade.

- [Electronic delivery direct from Mobile Geographics.](#) Get your password in seconds!



- [a CD version from Celestaire, Inc.](#) Or by phone at 1-888-navigate, 1-316-686-9785.



FAQ

Here are answers to some [frequently asked questions](#).

Register your CD purchase

If you have purchased the CD version of CelestNav™, [register here](#) for free upgrades.

CelestNav™ features:

- computation of fix position from celestial observations.
- perpetual nautical almanac for navigational stars, Moon, Sun, planets.
- Mercator and Great Circle sailing computation.
- computes range, height, sextant angle for lighthouses and other terrestrial objects.
- twilight, rise, set, meridian passage computation.
- automatic timing of sextant observations and adjustment to UTC.
- handles backsights, non-standard atmospheric conditions, and more.
- sight reduction screen with the functionality found in publications H.O. 229 and H.O. 249.
- continuously updated dead reckoning position.
- "finger-friendly" data entry screens for celestial observations, angles, dates, and times.

Look at some [screen shots](#) or read the [tutorial](#).

Buy these essential books:

•



• [2003 Nautical Almanac \(Commercial edition\)](#)

•



• [One Hundred Problems in Celestial Navigation](#). A collection of problem sets, with answers. Each chapter follows a segment of a voyage; the voyages are in different parts of the world, and different vessels (including a dirigible!). Gray makes no assumptions about how you're working the problems.

- [More navigation books](#)

Other navigation and astronomy software

These programs are written by others, but are very helpful in navigation.

[Astronomy software guide](#)

These programs are written by others, but are very helpful in navigation.

[Astronomy software guide](#)

Guide to astronomy and stargazing software for PalmOS.

[Tide Tool](#)

First-rate tide and current prediction tool. Covers the entire world except for the British Isles. Free!

[Big Clock](#)

Clock, timer, and stopwatch program. Also the easiest way to set the Palm's clock to the nearest second. Free!

Other handheld platforms

CelestNav™ requires PalmOS. It will not run on PocketPC platforms.

For a celestial navigation program and stargazing program that does run on PocketPC, we recommend [Pocket Stars](#), by Nomad Electronics.

Hardware:

[Buy your PalmOS handheld organizer online.](#)

[Mobile Geographics LLC](#) <webmaster@mobilegeographics.com>



**Select
Alliance Member**



Practice Bubble

[Top](#) : [Marine Sextants](#) : [Cheap Sextant](#) : Cheap Sextant

Cheap Sextant

Item#: 1609 - \$19.95

Search

More Search Options

Customer Service

Product Index

Ordering Information

Contact Us

Celestaire Home

Shipping Rates

United States

International

Shopping Cart

View Cart

Check Out Now

(requires Flash 5 plugin)

©Copr 92-2k **Omar F. Reis** - All rights reserved

The X-tant project

Build your own sextant

Note: Since I published this text, I've done another, much easier sextant using a CD and its box. Click the banner to the right to visit it.

But the octant described in this text is better ;-)



From times to times I get tired of writing abstract computer programs. This time I decided to do a more concrete project: a **sextant** (actually, an octant). I'm not a very experienced craftsman and don't have a equipped shop. The design is simple and can be reproduced with hand tools. I used a small jigsaw and a belt sander. I have made no blue prints.

In tests, when compared to a Davis plastic sextant, this octant did agree within 6' (see test results in the [bottom of this page](#)).



My octant parts ...

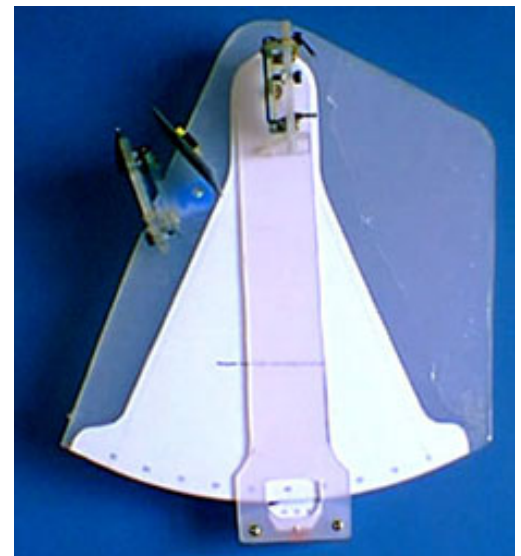

.. assembled

Printing the Scale

The scale is probably the most difficult sextant component to do using traditional techniques. It must be very precise and allow reading degrees and minutes, with accuracy at least within 5' of arc.

Fortunately, most of us have a precise printing equipment right on our desktop: a inkjet or laser printer. These machines can print 300 dots per inch (1200 for laser), with enough precision to print a good sextant scale.

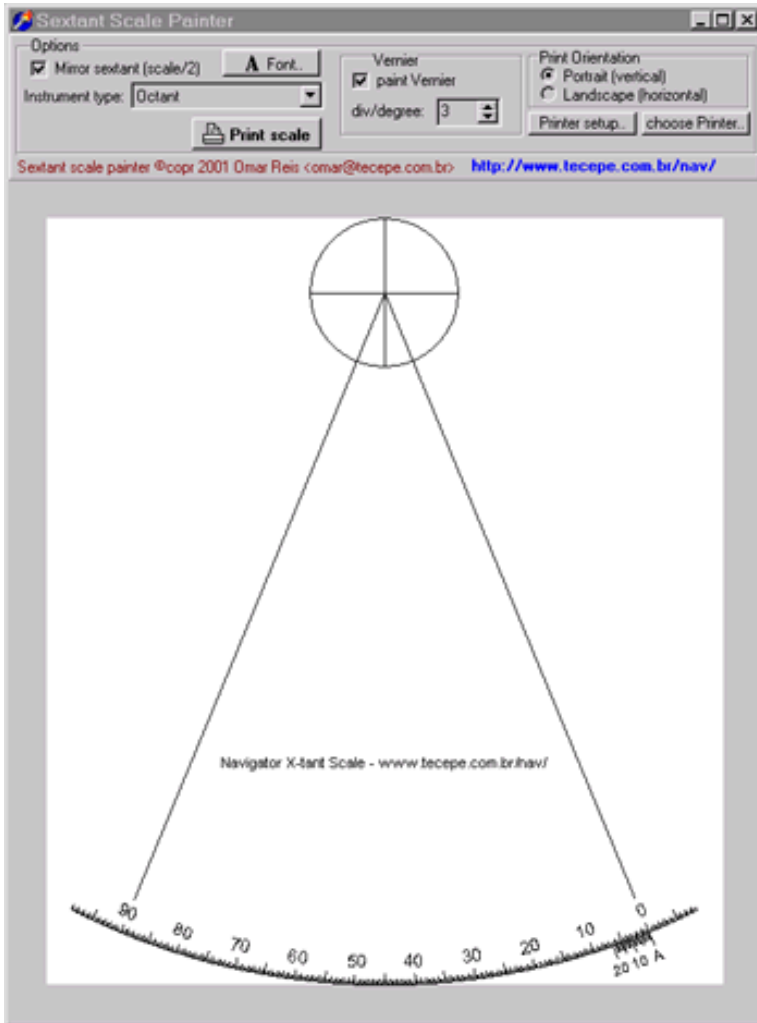

Laser or inkjet ?

Laser printouts are more resistant to water than inkjet ones. And have better resolution. Use a laser printer, if available.

But a inkjet printer will also do the work. If using a inkjet scale, protect it from water spray, either by adding a thin layer of transparent plastic or by taking extreme care with the instrument...

Sextant scale printer program

In order to achieve the best results, I wrote a small scale printing program. This will print the sextant scale using vector rendering, for best resolution. The scale will be the larger possible in the current printer page size.

To the left, you see a screenshot of my **XtantScalePrinter** program. I used the default options in my project, but you may experiment with other designs (sextant types, ticks per degree etc.).

XtantScalePrinter - download here

For Windows, 192.874 bytes - This program can be freely used for personal, noncommercial purposes, provided that the credit (name and URL) is not removed from the printed scales.

The Vernier scale

Since I didn't have the sophisticated machining equipment required, I discarded the idea of a drum sextant and went on to build a vernier scale sextant. Vernier sextants appeared before the modern drum sextants. In the vernier scale sextant, each degree in the scale is divided in 3 ticks (20' wide).

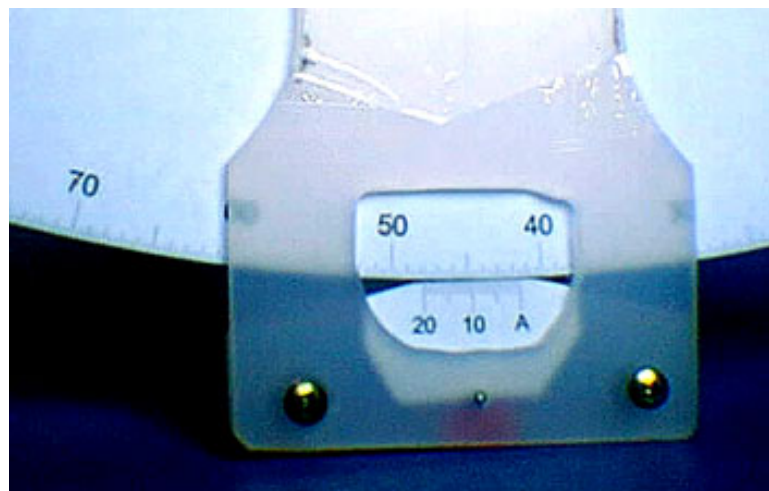

Vernier scale

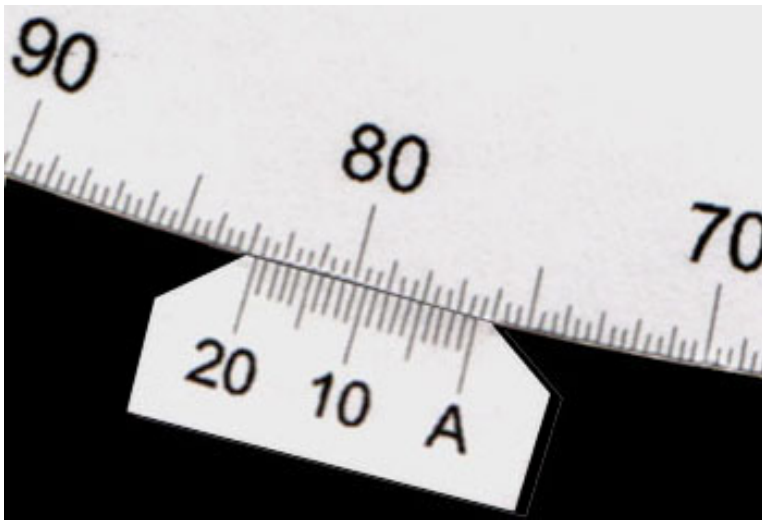

The vernier scale precision can be as good as a drum scale. The only difference is that the vernier scale requires a much more delicate handling of the sextant arm while trimming.

Reading the vernier scale is easy, once you get used to it. In the scale to the left, the index reads 76° with minutes between $20'$ and $40'$ (tick **A**). In the vernier, we can see that the 6th vernier tick coincides with the index tick, so the reading is $76^\circ 26'$.

Below are the three basic X-tant types. The octant can measure up to 90° , the sextant up to 120° and the quadrant up to 180° (see below). I choose to build an *Octant*, since this design fits better in a A4 printer page, giving the largest possible degree size in the scale, for best detail. And the 90° scale is enough for most observations.

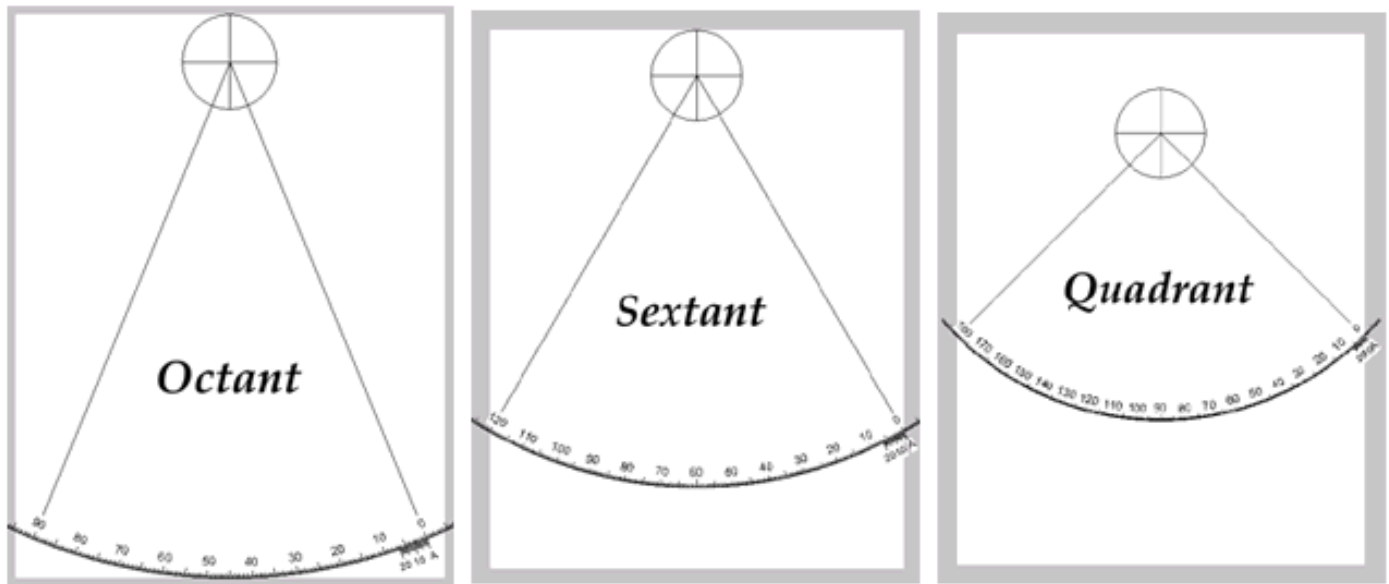

X-tant types

I used A4 ink jet sticker paper to print the scale (the ones used for printing labels). Choose a paper with no cuts. After printing the scale, check how good is your printer, using a compass to see if the index is a perfect circle segment.

Scale Transfer - An alternative way to print the scale was suggested by Mr. Schmit, by email:

"When you print documents with laser printers or photocopiers it is done by fusing the toner on the paper. You can transfer the print on any solid heat resistant material by refusing the toner with a very hot 'cloth iron'. Place the laser printed document on the cleaned material (printed side facing the surface) then apply the iron on the paper back just long enough to melt the toner. I used that to make gratings and reticules on glass or metal sheets and it's working fine if your print is strong enough... but the print must be reversed! "

While this reversed print is not directly supported by the scale printer program, most printer drivers (e.g.: HP) offer this as an option. Open the "Printer Setup" dialog, click "Properties" and check the "reverse horizontally" checkbox.

Another way was suggested by Mr. Kunnar:

" I used inkjet iron transfer paper. It is a kind of plastic that can be transfered to clothes using a hot iron. Since the ink ends up trapped between the sextant frame and the plastic layer, this scale is water proof".

Instrument frame

I used a 3 mm tick acrylic board for the instrument frame. This material is easy to machine and is relatively rigid. Acrylic boards are usually sold in large sizes, so you might want to search for someone who works with this material, in order to get the small piece you need with minimum expense.

The size of the sextant will depend on the printed scale size (that's why there is no blue print). So, you will only "design" the instrument after you have stick the scale on the acrylic board.

The acrylic board comes with plastic layers in both sides, for protection. It's a good idea to keep this protection as long as possible, because the acrylic will be easily scratched. I carefully lifted the plastic protection (see below), stuck the scale and put the plastic back in place, so the sextant scale was also protected while machining the frame.

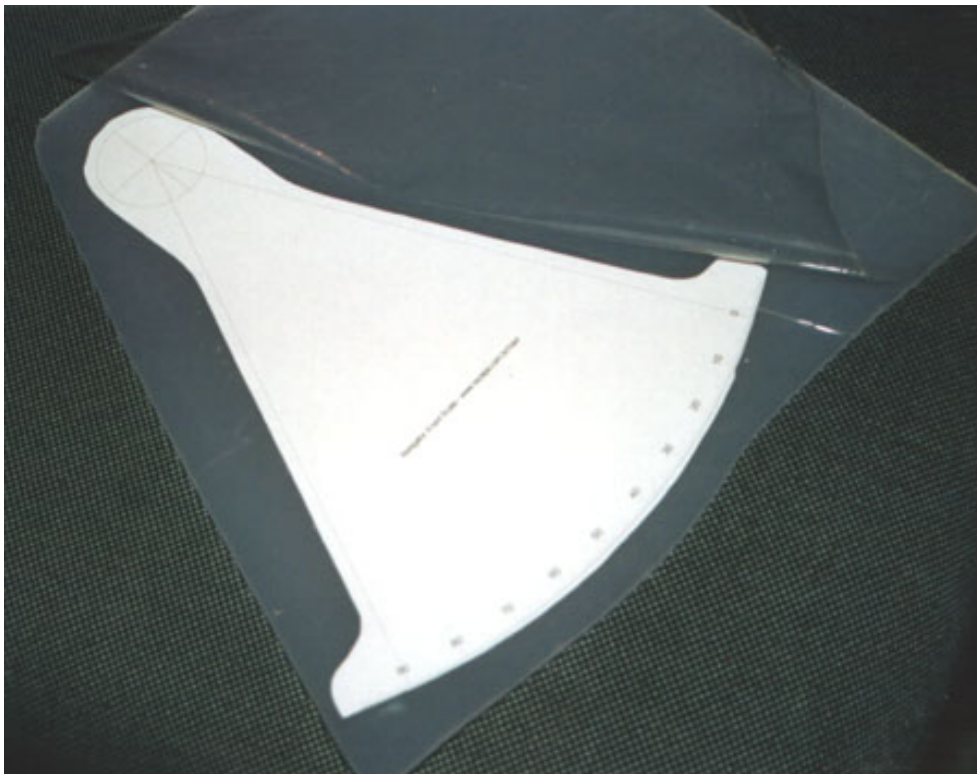

Lift the plastic protection, stick the scale, and put the protection back in place

After printing, cut around the scale, leaving like 3 mm around the outside line.

Sticking the printed scale in the board is a critical operation. It must be perfectly stuck, free of air bubbles or ripples. Otherwise the scale will not be correct.

Remove from the sticker paper backing completely. Hold it with the two hands and gently place in the acrylic board, the arm axis circle first. Then use one hand to spread the scale, while holding the other side. Keep the paper slightly tensioned, but not so much as to distort it. If you make a mistake, you probably will have to print another scale and start again.



Frame, arm and vernier, with cut lines

After this, you can use a marker pen to draw the parts (frame, arm and vernier).

The arm window (where the scale is read) must be sized and positioned so that you can see both the scale and the vernier touch point (that will define the arm radius). My octant arm is about 40 mm wide.

When designing the arm, measure the scale radius and add 10mm on either side (towards and away from the arm axis). My arm window is 30 mm wide.

The image to the left shows the 3 frame parts, marked and ready to be cut.

I cut the parts with an electric jigsaw, with thin teeth blade. Take care when cutting along the scale ticks. Never cut across the scale line. If you are careful, you can cut as close as 0.5 mm from the scale. Then you will have little trouble sanding out the rest, until you precisely reach the fine scale line. Use fine sanding paper for finishing the scale arc.

Also carefully cut and sand the vernier contact point, testing frequently against the scale arc. The vernier and scale contact must be as close as possible.

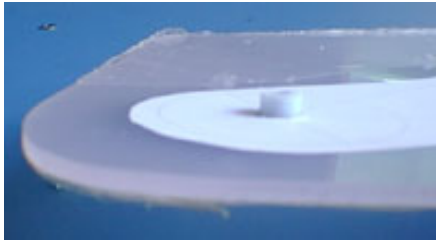
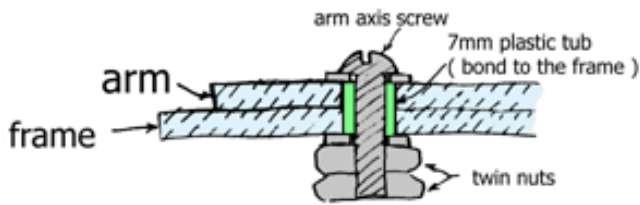

To drill the arm axis hole, first mark it with a hard point. Drill a 2mm lead hole and then a 7 mm hole. Use sharp drills. Do the same in the frame and make sure the hole center is precisely positioned.

I inserted a 7 mm hard plastic tube in the axis, so there is no contact between the arm and screw as the arm is moved (only between the tube and arm). Bond the tube to the frame.

The axis screw goes in the middle, with twin nuts. Make sure there is no slack in the arm axis setup

After cutting, drilling and sanding, you can assemble the arm and frame for the first time. Then you can position and bond the vernier in the arm, using a couple small drops of loctite (Cyanoacrylate glue). Use small self tap screws to secure the vernier.

If you did these steps right, the vernier should be in smooth, close contact with the index, as you slide the arm along the arc.

Add a plastic device in the back of the arm to press it against the frame (the green part on the left image). It is important to have some friction between the arm and frame, so the instrument will hold the reading if left alone (i.e. the arm will not move by itself). This is also important for fine trimming.



Mirrors

I used 2 equally sized glass mirrors (46 mm x 24 mm, 3 mm thick). Any glass shop will cut these for you. As you know, one of the mirrors must be half silvered. So you must remove half of the mirror silver backing. I used a paper cutter blade for this job (Olfa cutter).

First make a sharp longitudinal cut along the middle of the mirror. Then scratch half of the epoxy protective layer from the back of the mirror, with the blade inclined. The epoxy backing is a hard material, but will come out with patience. Don't use any abrasive material or the blade point, to avoid scratching the glass. Once the epoxy is gone, the silver is easy to remove, rubbing hard with a wet cloth. In the end, the glass must be clear and scratch free (fig. below).

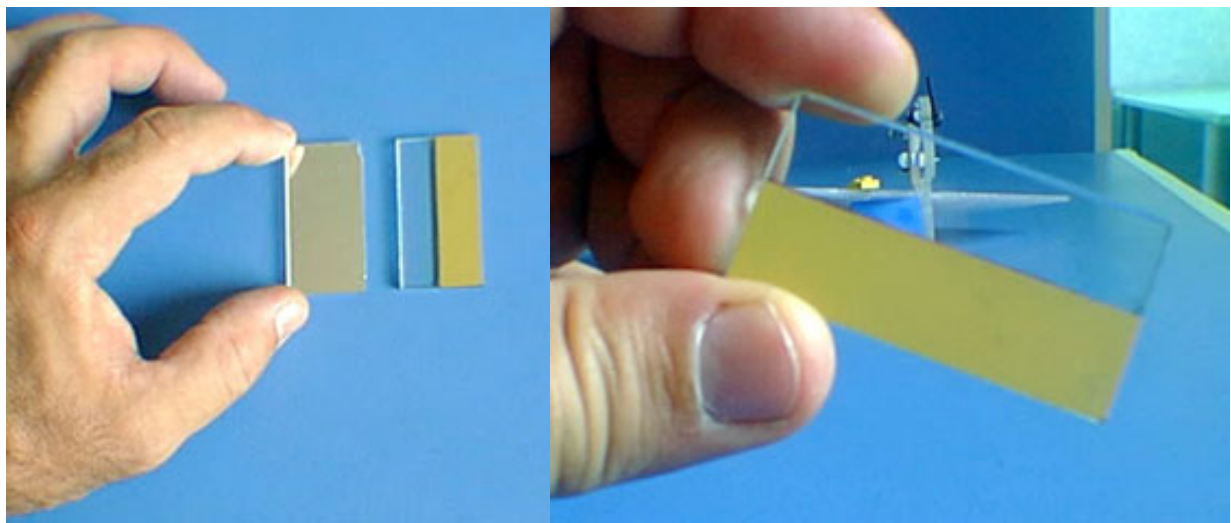

Mirrors

Note: You may be tempted at this point to use a thinner mirror and eliminate the transparent part altogether. Don't do that. This would introduce a refraction error. The direct (horizon) light ray must pass thru the glass, as the light ray from the star does.

This can only be done if you use a front mirrored surface, such as a polished inox plate.

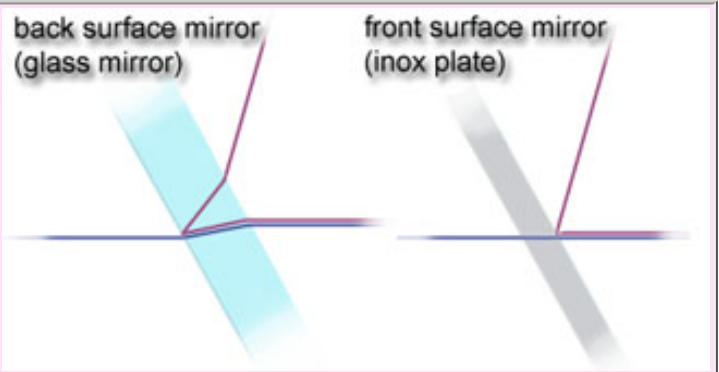

Mirror holders

I used a thicker acrylic for the mirror holders (4mm), as these parts are sometimes subjected to abuse. They will also have to be fixed with self tap screws so a thicker material is better.

Both mirrors must be supported by three contact points (from geometry, we know that 3 points are required to define a plane). I used 3 supporting screws to position each mirror. Some of the screws are adjustable, for mirror trimming, and some are fixed. For the adjustable screws, I used Allen screws, which have a large head, easy to turn by hand. The fixed points are regular inox nut screws.

Make a point in all screw tips, to reduce the contact area between mirror and screw to a point. I also added thin metal plates to prevent the mirrors from moving sideways while trimming.

To ensure a perfect contact between the 3 screws and mirror, I used rubber bands (see right). These press the mirrors against the screws. Commercial sextants use metal springs for this function, but I could not find any suitable part in my junk collection.

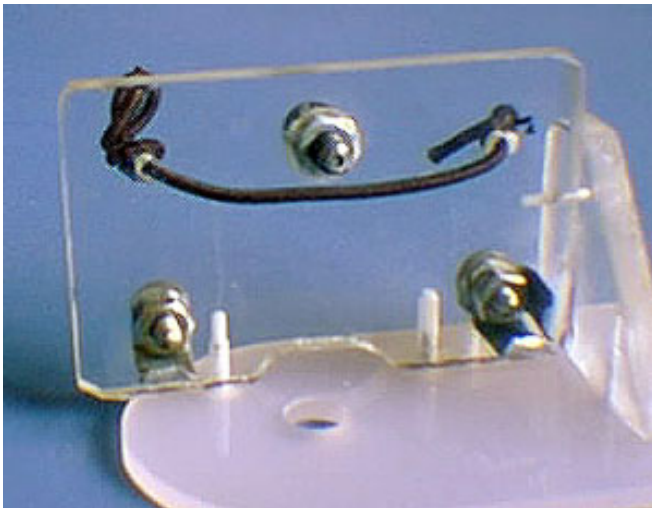
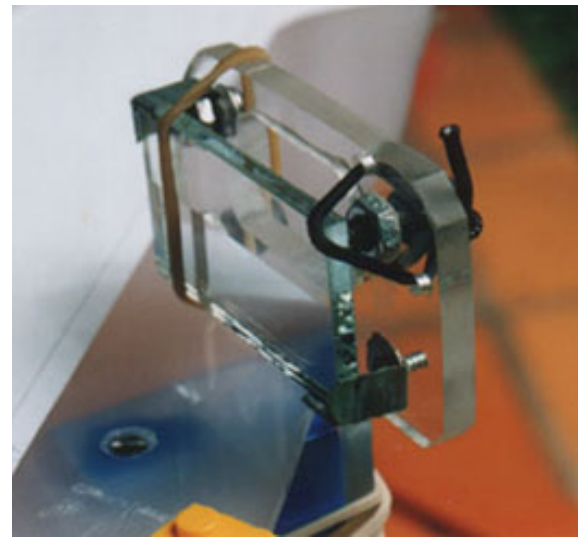

Arm Mirror setup

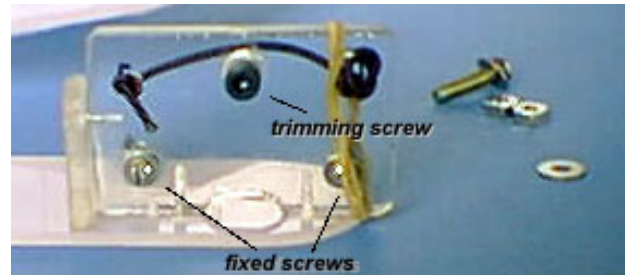

backview

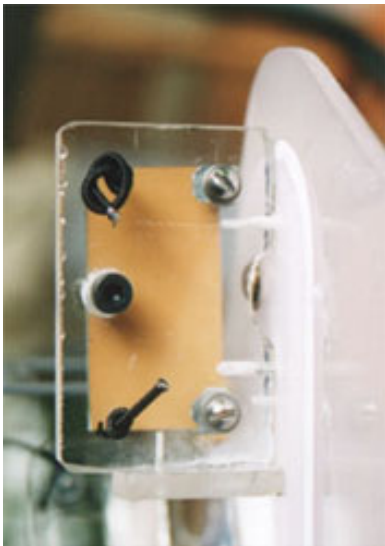

The **arm mirror holder** is basically a rectangle, with a side supporting plate. The arm mirror has one adjustable screw (top screw in the figure above). Make a 1mm deep housing for the adjustable screw nut and bond it to the acrylic, so it won't move when you trim the screw.

The **frame mirror holder** is a T shaped part, with 2 adjustment screws (below). Cut a window, so that the sight through the glass part of the frame mirror is clear.

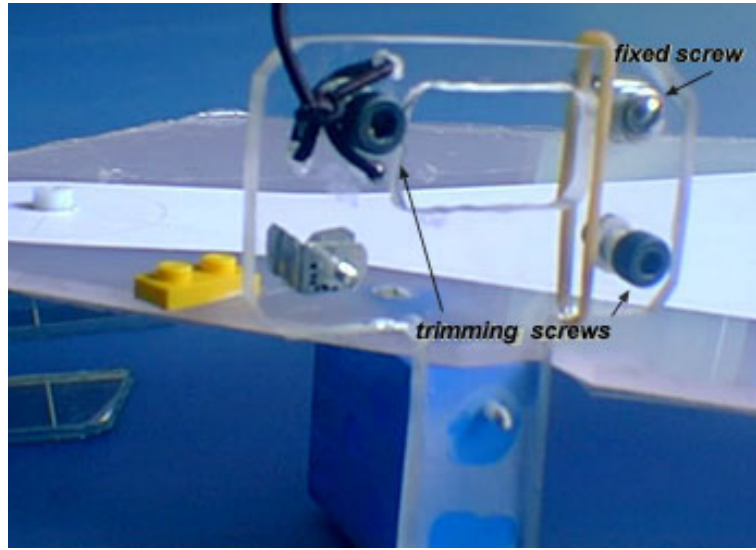
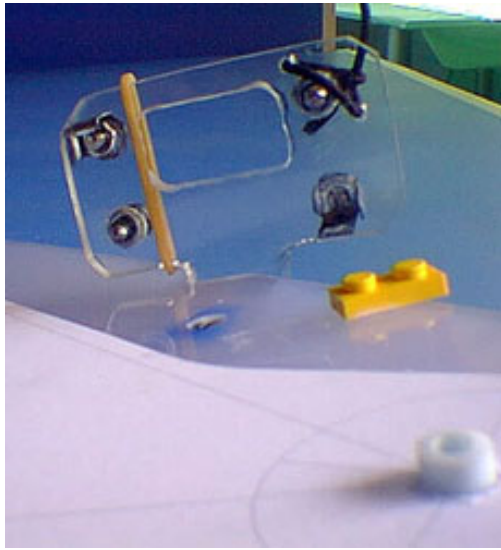

After completing the two mirror holder setups (i.e. after drilling, cutting, sanding and securing the mirror screws), you can bond them to the frame and arm. Start with the arm mirror.

The arm mirror assembly must be positioned so that the center of the mirrored surface (the back surface of the mirror) is over the arm axis center. This way the center of the mirrored surface (i.e. the back of the mirror) remains fixed while the arm is moved.

Make sure you have space to introduce and remove the arm axis screw, or you won't be able to assemble and disassemble the arm. After bonding with Loctite, use small flat head self tap screws to secure the assembly to the arm. Make a housing for the screw head, to avoid interfering in the arm movement.

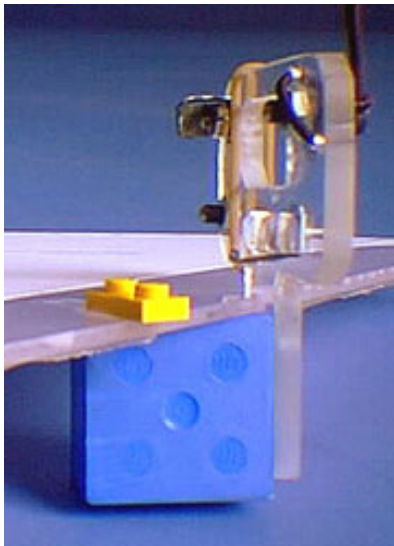

After securing the arm mirror assembly, set the arm to 0°00' reading and place the frame mirror assembly parallel to the arm mirror. I used a Lego Duplo block (the large blue piece) to support the frame mirror assembly. This way the right angle between the frame mirror and instruments plane is guaranteed.

I like to use Lego parts (no, I'm not **Leg**o sponsored) because they are widely available (at least in my house floor), have good dimensional precision and there are all sorts of blocks and devices.

Make sure both mirror holders are firm, by bonding and securing with screws. Having reached this point, you already have a sextant to take twilight sights. But you still need shades to take Sun sights.

Shades

As shades for Sun and Moon sights, I used 35 mm dark negative photography film (there is one in the end of every film roll). The negatives were mounted in slide frames. I used double negatives for the Sun frame and single for the Moon.

Both slide frames are removable and are attached to the instrument frame using Lego blocks (the yellow one in the pictures above). I must say I'm not happy with this fixation solution. A more skilled (less lazy) craftsman would probably do a better job, with some pivoting design.

The thing to watch here is the shade position. The filter surface must be orthogonal to the line connecting both mirror centers. This is to avoid introducing a refraction error. Try to position the slide center in the line connecting the two mirror centers.



Sun shade

Don't make the same mistake I did, letting the shade support interfere with the arm at large angles. The arm must go at least up to 90° (for the octant).

No eyepiece ?

I was looking for a good 2x or 3x small telescope that I could use as an eyepiece for my sextant. I played with small toy telescopes, but results were poor. In the end, I decided to use no eyepiece. This actually gives a lot of freedom handling the sextant.

When taking a sight, remember to hold the instrument so that your eye is on a plane parallel to the instrument's and containing the fixed mirror silver-glass division. This is easy to find: turn the instrument up until you face the fixed mirror. In this position, you should see half of your eye in the silvered part of the mirror. Move it sideways until you see it. Then turn the instrument back down to observation position.

Trimming the mirrors

Trimming this octant is no different then any other sextant.

First trim the arm mirror adjustment screw. The arm mirror must be perpendicular to the arm/frame plane. This may be checked by looking at the index scale reflected in the arm mirror. The reflected index must be perfectly aligned with the index part you see directly (green arrow on the right).



Then trim the frame mirror. This is a little trickier, because two screws have to be trimmed simultaneously. Set the arm to 0°00' and point the instrument to a far object (like a star or boat far away). Then trim the two screws until the object remains a single image while you swing and rock about the instrument axis.



Sun sight

As future improvements, I would change to a better shade positioning system, add a nice handle and a case (I'm currently using a cardboard box). The case is probably the most important of the three, for a sextant - like a violin - is not be left hanging around, if it is to last long.

There are many materials, design ideas and garage junk devices that can used to build a Sextant. If you build such an instrument - using these ideas or not - I would like to hear about it. I would also be happy to publish other design solutions here.

A sextant is a fun thing to build, and getting a precise reading from your own instrument is one thing that will make you feel good.

Sextant Field Test

I did some tests comparing the same vertical angles, measured by 3 different instruments:

1. A Kern theodolite
2. A Davis MK15 plastic sextant
3. My Octant

The theodolite (a survey instrument) is presumably more precise than the sextants and was used as a benchmark. Sextant angles were corrected for index error. I measured 4 vertical objects, obtaining the following results:

Object #	Kern theodolite	Davis sextant		My Octant	
1	7°41'	7°42'	+1'	7°42'	+1'
2	22°24'	22°19.5'	-5'	22°25'	+1'
3	41°37'	41°44.5'	+7'	41°42'	+5'
4	56°42'	57°01'	+19'	56°55'	+13'

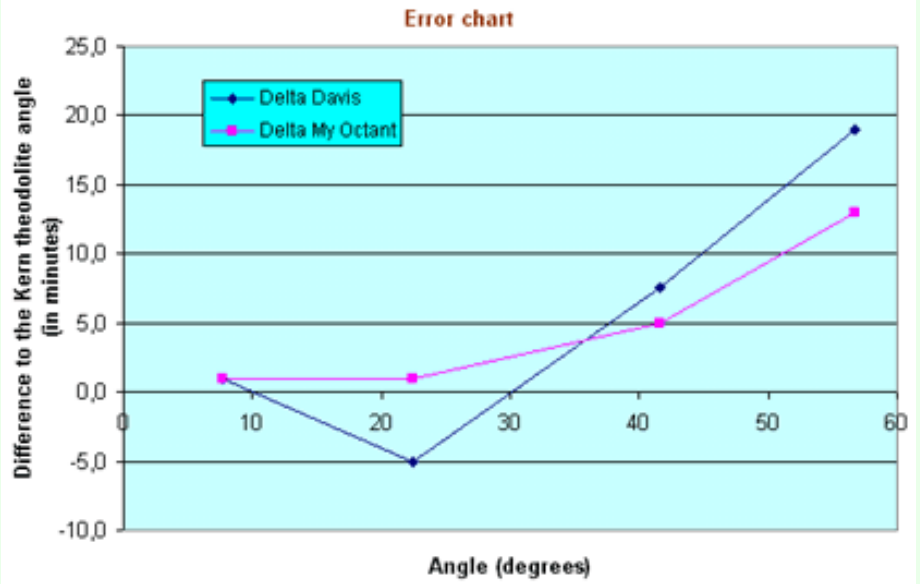

Bibliography

>> "**The American Practical Navigator** " by Nathaniel

Bowditch

ISBN 0781220211 - 1200 pages

buy from **Amazon**

History:

1. (jun/02) - Added text about inkjet printed scale problem with water spray.
2. (oct/02) - Added a arm axis screw diagram
3. (nov/02) - Added sextant test results and note about laser print transfer.
4. (fev/04) - Added note about mirror refraction

©Copr 92-2k **Omar F. Reis** - All rights reserved

Reader Page

Kind reader Harold Arsem sent me two pdf files of worksheets for those using HO 249. You need a free pdf reader to open these, available at www.acrobat.com.

[Worksheet 1](#)

[Worksheet 2](#)

Peter Kempees has sent the following for my European readers:

The German Amazon -- www.amazon.de (in German) -- sells the cardboard sextant online. Might be of interest to European readers, perhaps. So does this French site: <http://www.navastro-boutique.com/index.html> (in French). And here is the German manufacturer: <http://www.sunwatch.de/seiten/produkte/instrumente/sextant.htm> (in German).

The English version of the cardboard sextant kit is available at [Celestaire](#).

• [Home](#) • [Why Celestial Navigation?](#) • [History](#) • [Navigational Astronomy](#) • [The Theory](#) • [The Practice](#) • [Celnav in the Classroom](#) • [Vikings](#) • [Navigational Instruments](#) • [Wayfinding](#) • [Schools](#) • [Quotations](#) • [Resources](#) • [Dante](#) • [Other Links](#) • [Webmistress](#) •

**Book
Categories:**

 Celestial Atlases
& Catalogs

 CCD's &
Astrophotography

Handbooks

 Math & Celestial
Mechanics

 Photoelectric
Photometry

Almanacs

 Telescope Making
& Optics

 History of
Astronomy

Navigation

 ON-LINE
ORDERING

HOME

WHAT'S NEW

SOFTWARE

 SOFTWARE
UPGRADES

AstroNavPC and Compact Data 2001-2005:

Astro-Navigation Methods and Software for the PC

by Her Majesty's Nautical Almanac Office, 6 by 9 inches, 152 pages, includes AstroNavPac on IBM-PC readable CD-ROM. Ship wt. 1 lb. 8 Ozs., \$34.95.



[View the Table of Contents](#)

(requires Adobe Acrobat)

[View Screen Shots and Take a Quick Tour](#)

This book provides ready-to-use software, algorithms and tables developed by Her Majesty's Nautical Almanac Office for calculating the positions of the Sun, Moon, navigational planets and stars to a consistent low precision (about 0'.1).

The software package, AstroNavPC, which meets the requirements of the Royal Navy is supplied on a CD-ROM and enables navigators to compute their position at sea from observations made with a marine sextant using an IBM PC or compatible for the period of 1986 January 1 to 2005 December 31.

The software includes functions for calculating distance and course between

two locations on a rhumb line or great circle track, together with way points, although these algorithms are not described in this book. AstroNavPC also deals with journeys that consist of several discrete changes in speed and/or course, called legs. It also calculates times of rising and setting, including civil, nautical and astronomical twilight, for any location and for all the navigational (heavenly) bodies. It will also calculate the altitude and azimuth of the bodies, and displays their positions on the screen. The Greenwich hour angle and declination of the bodies, including the Greenwich hour angle of Aries may be displayed in the form of an almanac. These features are useful for planning astronomical observations, and for determining the observability of the bodies. The navigational bodies involved are the Sun and Moon, the navigational planets, Venus (centre of light), Mars (centre of light), Jupiter and Saturn, the 57 navigational stars (published in *The Nautical Almanac*), and the pole stars, Polaris and sigma Octantis. The precision of GHA, DEC and where appropriate, horizontal parallax and semi-diameter, is around 0'.1 except for the Moon when it is 0'.2.

For those navigators and astronomers who want simple and efficient methods suitable for a small programmable calculator or a personal computer both algorithms and tables are also provided. The main tables contain monthly polynomial coefficients for calculating the Greenwich hour angle (GHA) and declination (DEC) of the Sun and navigational planets, daily polynomial coefficients and monthly Chebyshev coefficients for calculating GHA, DEC and horizontal parallax of the Moon, and five yearly coefficients for calculating the GHA and DEC of the navigational stars. These ephemerides and methods are also used by AstroNavPC. As a further aid to do-it-yourself programmers the CD-ROM also contains the compact astronomical data (1986-2005) in ASCII format, enabling the data to be read directly into a PC.

In 1767, the first *Nautical Almanac* was published under the auspices of the fifth Astronomer Royal, Nevil Maskelyne. Some sixty years later, the *Nautical Almanac Office* was established at the behest of the Royal Society to ensure that *The Nautical Almanac* and other astronomical data were published to a high standard. These were the requirements of both the astronomical community and the *Nautical Almanac Act of 1828*. In 1911, as one of the top five almanac producers in the world, HM Naval Office (NMNAO) started a collaboration with the U.S. Naval Observatory and others which continues to this day. This collaboration is stronger than ever and is responsible for *The Nautical Almanac* and *The Astronomical Almanac* and several other more specialised publications for the Armed Forces, Seafarers, Surveyors, as well as Astronomers. HMNAO enjoyed a long association with the Royal Greenwich Observatory until its closure in 1998. The Office continues to produce astronomical data for a wide range of users from its new home at the

Rutherford Appleton Laboratory.

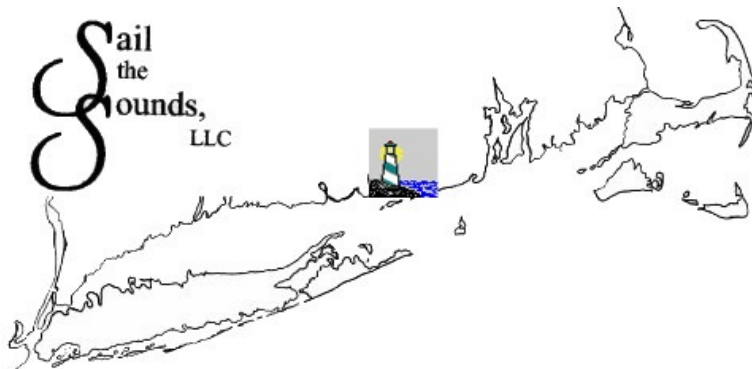

**American
Sailing
Association
Training
Center**

Basic day sailing through ocean cruising

CT Safe Boater License

Docking Clinic

Basic Chart & Compass Navigation

Electronics (GPS">

Sail
the
Sounds,
LLC



 **American Sailing
Association Training Center**

Basic day sailing
through ocean
cruising

CT Safe Boater
License

Docking Clinic

Basic Chart &
Compass
Navigation

Electronics (GPS,
computer chart
plotting)



--Our Sailing Club Training Package is the fastest and most economical way to learn!! The Navigation Package is necessary for your safety and confidence - from basic compass courses through electronic charting and GPS interface!! Complete our three-day Bareboat Charter Certification Course and then take one of our charter vessels on a weekend cruise with family and friends!! We are the only ASA Training Center in New England Offering Cruising Catamaran Bareboat Charter Certification -- three days and two nights liveaboard only \$699 per person!! Or Bareboat (BBC104) & Cruising Catmaran Certification (CC114) Cruise May 12-16, 2004 Aboard "MystiCat" from Maine to Mystic!!-----

Sail along with our Bareboat Certification students for a FUN FLOTILLA Cruise. Just \$195 per day. Contact us for more details. See Course schedule for dates.

Become a Certified Sailor through the US Coast Guard approved American Sailing Association training program at Sail the Sounds in Mystic Connecticut. The premier sail training center in New England. Our courses are taught by American Sailing Association's

"Outstanding Instructor" for five consecutive years!!

(Click on for photo and biography)



Course Descriptions & Goals

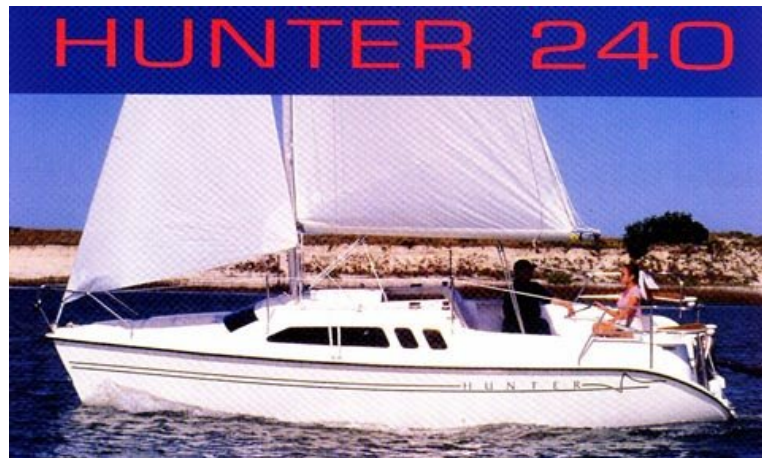

Sailing Club Training Package

\$1399

Two days classroom & seven non-consecutive days on the water

For the beginning sailor who wants to rapidly move to Club Membership and enjoy unlimited sailing of the Hunter 240 Daysailer fleet; includes Basic Day sailing (BKB101; one weekend) and the CT Safe Boater Exam, Coastal Navigator (CON105; one weekend), and Coastal Cruising Certifications (BCC103; two days with overnight stay on vessel); plus three full or six half-days use (at your convenience following completion of BKB101 weekend) of vessels in the Sailing Club fleet (*Regular And Captain's Club Members have weekend priority*).

Basic Day sailing ASA-BKB101 \$375
0830-1800: Minimum two & max. four students.
Two consecutive days; weekends or weekdays

[Sailing Points of Sail Simulator](#) (click to go to linkage)

Learn terminology, theory, safety rules in the classroom. Then board one of our new Hunter 240 training vessels for on the water training in boat rigging, handling, maneuvering under sail and outboard power. Practice man overboard procedures, heaving-to and anchoring.



Graduate can operate a similar vessel in daytime hours in familiar waters, in moderate (under 20 knots) wind, can instruct crew in their responsibilities. Becomes eligible to join our Sailing Club. *Qualifies student for required Connecticut Safe Boater Certificate.*

Prerequisite for BCC103 by course completion or examination.

Coastal Cruising ASA-BCC103 \$399
0900-1800: Minimum four & max six students.
Two days plus overnight stay on vessel

BKB101 required and CON105 recommended as prerequisites.



(click on to enlarge)

Sail aboard a 30+' yacht with diesel inboard. Learn to operate engine and live-aboard systems. Set compass courses to coastal destinations using charts, navigation instruments, buoys and markers. Maintain proper charting procedures, anchoring and docking practice. Man overboard drills.

Prerequisite for BBC104 by course completion or examination.

Bareboat Charter ASA-BCC104 -- \$750.00/person (does not incl. provisions)
0900 first day to 1700 last day Minimum four & maximum six students
3 days live aboard

Learn to sail vessels up to 50' in all conditions: live-aboard techniques for vacation cruising; GPS navigation. Three days aboard 37'-50' vessel. A two-day independent cruise within 90 days may also be required. Eligible for bareboat chartering and 15% fee discount in same season from our charter fleet upon completion of course.

[Wave Simulator](#) (click on to linkage)

BK101, CON105, BCC103 required as prerequisite.

NEW NEW NEW

Cruising Catamaran (CC114 -- \$699 per person)

(Endorsement to Bareboat Charter ASA-BBC104 Certification)

Prerequisites: Basic Keelboat, Basic Coastal Cruising, Bareboat Charterer

General Description: Sailors must safely act as skipper or crew of a 30 -50 foot catamaran sailing by day in coastal waters. The Standard includes knowledge of boat systems and maintenance procedures. This is an endorsement to 104 and 113 (Trailerable Multihulls) is not required.



Go to www.mecat.com to learn more.

Three days liveaboard; day one includes 4 hours classroom and 4 hours aboard; day two is aboard and underway; day three is unrestricted sailing by student and may be bareboat sailed by student with crew day three upon recommendation of instructor.

(click on [MystiCat](#))

OR

Earn your Bareboat (BBC104) & Cruising Catmaran Certification (CC114)

Cruise May 12-16, 2004 Aboard "MystiCat" from Maine to Mystic

\$800/person plus provisions and travel.

Navigation Training

CON105 Basic Navigation

Plus

SS108 Electronic Chart and GPS package

\$400

(\$450 if enrolled separately)

Coastal Navigation - CON105 \$350 (incl. Texts, Workbook and Charts)

0900-1730: Minimum four & max, eight students.
Two days; weekends only.



(Click to enlarge photos)

Learn to use charts and compass for low visibility navigation. Compensate for tides and currents. Correctly interpret chart symbols and notation. Know GPS error factors. Confidently and safely cruise the New England Coast in all visibility conditions. Charts and instruments provided. Certification as American Sailing Association Coastal Navigator.

Click on <http://tbone.biol.sc.edu/tide/index.html> for tide and current predictor.

Prerequisite for SS 108 Electronic Navigation and Bareboat Charter Certification.

Equivalent to all US Power Squadron piloting courses in only two days.



SS108 – Electronic charting and navigation

\$100.00/person.

Instructor – Captain Jim Scoggins

A one-day (0900-1700) course introducing computerized trip planning and electronic GPS & GPS/chart plotter. Increase your accuracy in navigation planning; become a safer boater; avoid accidental groundings, and cruise more efficiently. *CON105 Coastal Navigation is recommended prerequisite.*

We provide the Maptech Digital ChartKit software, notebook PC's, Garmin 2010c color display GPS/plotter, Garmin handheld GPS models 45, 76, & 76 map; or you can bring your own PC, chart plotter and GPS.

New – Digital ChartKit from [Maptech](#) – The Place to Start

NOAA Charts, NavPhotos, Marine Facilities, Software & more...under \$200 per Region

Maptech (Amesbury, MA) – Why navigate with last year's charts and risk an accident or damage to your boat or yourself? Using the latest NOAA charts for marine navigation is vital. But most boaters and fishermen are unaware of how many significant chart changes are made each year by NOAA. Safer navigation on US waters is dependent on using the latest chart information. Over 50% of the NOAA charts in Digital ChartKit are new or revised from last year.

Maptech Digital ChartKit includes all the latest NOAA chart revisions – a Maptech exclusive. Along with the latest NOAA chart editions Maptech includes thousands of weekly Notice to Mariners corrections. The technology to integrate these weekly changes into new chart editions is a Maptech exclusive. Changes include new buoy locations, new or deleted lights, channel shifts, wrecks and more.

Along with the new and revised charts in Digital ChartKit are everything a boater needs to get started in electronic marine navigation. It's the 'Place to Start.' Digital ChartKit combines the latest official NOAA charts, navigation photos, aerial pictures, coastal topographic maps, marine facilities locator, tides and currents, and more for under \$200.

Gavin Johnston, VP Marketing & Sales, says, "Digital ChartKit is clearly 'The Place to Start.' Anyone getting started in marine navigation faces a lot of choices and it can get confusing. Digital ChartKit makes it easy for new and experienced boaters to get started in computer navigation and at a price that is very reasonable."

Digital ChartKit includes: 'The Place to Start' -- Regions follow the BSB standard

- NOAA digital charts – the only *official* charts available for US waters
- Navigation Photos – georeferenced to match your chart position exactly
 - USGS coastal topographic maps– extending 5 miles inland
- Aerial Pictures – approaches to harbors and key coastal locations (overlay on charts)
- Marine Facilities Locator -- from Embassy Cruising Guides – (overlay on charts)
 - Tides & Currents Database – (overlay on charts)
- USCG Coast Pilot and Light List – shows danger spots and obstacles
- Chart Navigator software – makes GPS better – easy upload/download of routes/waypoints.
- Print chart, maps, photos, data overlays, with or without GPS routes and waypoints
- Digital ChartKit Pro is the official raster chart and up-date service for the U.S. Coast Guard

Plan your next cruise anywhere between Cape May, NJ & Nantucket, MA.

Docking Clinic

\$100

Two hours instruction aboard your vessel - includes proper dockline placement and handling; analysis of wind and current effects on your vessel under various conditions; backing into your slip; use of docklines and fender board for slip entry under heavy winds.

Private Lessons

\$50.00 per hour with a \$200.00 minimum

Private Lessons are available on your vessel or ours. Per diem charter fee is additional on our charter vessel for private lessons. Travel expenses to your vessel @ .40 per mile.

2004 Course Schedule

2004 SailSounds Schedule - Training																																
Mar	Mon	Tue	Wed	Thu	Fri	Sat	Sun	Mon	Tue	Wed	Thu	Fri	Sat	Sun	Mon	Tue	Wed	Thu	Fri	Sat	Sun	Mon	Tue	Wed	Thu	Fri	Sat	Sun	Mon	Tue	Wed	Mar
	1	2	3	4	5	6	7	8	9	10	11	12	13	14	15	16	17	18	19	20	21	22	23	24	25	26	27	28	29	30	31	
					CON105															CON105												
Apr	Thu	Fri	Sat	Sun	Mon	Tue	Wed	Thu	Fri	Sat	Sun	Mon	Tue	Wed	Thu	Fri	Sat	Sun	Mon	Tue	Wed	Thu	Fri	Sat	Sun	Mon	Tue	Wed	Thu	Fri	Apr	
	1	2	3	4	5	6	7	8	9	10	11	12	13	14	15	16	17	18	19	20	21	22	23	24	25	26	27	28	29	30		
		CON105													CON105																	
May	Sat	Sun	Mon	Tue	Wed	Thu	Fri	Sat	Sun	Mon	Tue	Wed	Thu	Fri	Sat	Sun	Mon	Tue	Wed	Thu	Fri	Sat	Sun	Mon	Tue	Wed	Thu	Fri	Sat	Sun	May	
	1	2	3	4	5	6	7	8	9	10	11	12	13	14	15	16	17	18	19	20	21	22	23	24	25	26	27	28	29	30	31	
	CON105													MystiCat to Mystic							CON105								Club Orientation & Cookout			
Jun	Tue	Wed	Thu	Fri	Sat	Sun	Mon	Tue	Wed	Thu	Fri	Sat	Sun	Mon	Tue	Wed	Thu	Fri	Sat	Sun	Mon	Tue	Wed	Jun								
	1	2	3	4	5	6	7	8	9	10	11	12	13	14	15	16	17	18	19	20	21	22	23	24	25	26	27	28	29	30		
					CON105														SS108 Electron Nav													
				BKB101							BKB101						BKB101						BKB101									
				BKB101							BKB101						BKB101						BKB101									
											BCC103												BCC103									
																									CC114							
																									BCC104							
Jul	Thu	Fri	Sat	Sun	Mon	Tue	Wed	Thu	Fri	Sat	Sun	Mon	Tue	Wed	Thu	Fri	Sat	Sun	Mon	Tue	Wed	Thu	Fri	Sat	Jul							
	1	2	3	4	5	6	7	8	9	10	11	12	13	14	15	16	17	18	19	20	21	22	23	24	25	26	27	28	29	30	31	
				CON105														SS108 Electron Nav														
				BKB101							BKB101						BKB101							BKB101								
				BKB101							BKB101						BKB101						BKB101									
											BCC103														BCC103							
																										CC114						

Aug														Aug																		
Aug	Sun	Mon	Tue	Wed	Thu	Fri	Sat	Sun	Mon	Tue	Wed	Thu	Fri	Sat	Sun	Mon	Tue	Wed	Thu	Fri	Sat	Sun	Mon	Tue	Wed	Thu	Fri	Sat	Sun	Mon	Tue	Aug
1	2	3	4	5	6	7	8	9	10	11	12	13	14	15	16	17	18	19	20	21	22	23	24	25	26	27	28	29	30	31		
							BCC104														SS108 Electron Nav											
BKB101						CON CON105										BKB101												BKB101				
BKB101						BKB BKB101										BKB101												BKB101				
						BCC BCC103																										
														BBC104																		
																					CC114											
Sept														Sept																		
Sept	Wed	Thu	Fri	Sat	Sun	Mon	Tue	Wed	Thu	Fri	Sat	Sun	Mon	Tue	Wed	Thu	Fri	Sat	Sun	Mon	Tue	Wed	Thu	Fri	Sat	Sun	Mon	Tue	Wed	Thu	Sept	
1	2	3	4	5	6	7	8	9	10	11	12	13	14	15	16	17	18	19	20	21	22	23	24	25	26	27	28	29	30			
					CON105															SS108 Electron Nav												
BKB101																		BKB101										BKB101				
BKB101																		BKB101										BKB101				
								BCC103																								
																										CC114						
																								BBC104								

CON105 – Coastal Navigation Certification - Two consecutive days, classroom only
SS108 - Electronic Navigation - Monthly, alternates Saturday and Sunday



BKB 101 – Basic Keelboat Certification
Two consecutive days aboard the Hunter 240

Every weekend, June through September; weekdays on request.



BCC103 – Basic Coastal Cruising
Two days aboard a 34' or 40' sailing vessel; stay aboard overnight



BBC104 – Bareboat Charter Certification
3 live aboard days on a 40' sailing vessel– also is a FUN FLOTILLA cruise
Friday through Sunday



CC114 - Cruising Catamaran endorsement to BBC104 (above)
3 live aboard days on MystiCat, our 30' cruising catamaran– also is a FUN FLOTILLA cruise
Last Friday through Sunday, June through September (1st class June 25-27, 2004)

Meet Your Instructors!!

(Click on name or photo for brief biography)



[Capt. Jim Scoggins](#)



[Capt. Terry Leahy](#)



[Capt. Alan Nevols](#)



[Ken Caya](#)



[Rob Fornwald](#)



[Mike LaChance](#)

[Home](#)

[About Us](#)

[Sailing Club](#)

[Charter Boats](#)

[FAQS](#)

[Contact Us](#)

[Links](#)



Send us a message



**Current Edition:**

0

Corrected through U.S. Notice to Mariners No.

38/2004 (18 September 2004)

This publication contains the following sections. Click the link to view a section on-line or download the file using your web browser's download mechanism. All documents are in **PDF format**. In order to view them on-line, you must have the Adobe Acrobat Reader© plug-in installed in your browser. For help on viewing/downloading, click [here](#).

Note

You may notice a chapter/filename mismatch for some chapters. This is a result of the elimination of former Chapter 29 and the subsequent renumbering of the remaining chapters. The original file names were retained to preserve the indexing links already built into the documents.

Download Entire Publication

How David Thompson Navigated

[Home](#)

[Article Index](#)

Message to the Reader

I apologize for the considerable space in this volume of *Northwest Journal* which is devoted to early 19th century navigation, as many readers may have only a passing interest in this topic. However, please recognize that the vast majority of the information presented in these articles has never before appeared in print. Such a complete assessment of David Thompson's techniques and skill has *never been done before*. I hope that the information in these articles will spur new interest in assessing the skills and contributions made by *all* North American geographers of that time. —J. Gottfred

Contents

[See also Period Navigation](#)

[Art I. Understanding How Thompson Navigated— Introduction to the Case Study](#)
By J. Gottfred.

[Art II. Assessing David Thompson's Surveying Skill— Guidelines for Historians.](#)
by J. Gottfred.

[Art III. The Location of David Thompson's 'Goods Shed' on the Athabasca River,](#)
by J. Gottfred.

[Art IV. Using David Thompson's Sextant Index Error to Show his Diligence and](#)

High Accuracy. By J. Gottfred.

Art V. Recomputing Thompson's Data— Latitude by Double Meridian Altitude. By J. Gottfred.

Art VI. Recomputing Thompson's Data— Latitude by Double Altitudes. By J. Gottfred.

Art VII. Recomputing Thompson's Data— Greenwich Apparent Time by Lunar Distance. By J. Gottfred.

Art VIII. Recomputing Thompson's Data— Longitude from GT, Local Time, Magnetic Variation. By J. Gottfred.

Art IX. A New Latitude for the Goods Shed Computed from Thompson's Data. By J. Gottfred.

Art X. Glossary and References. By J. Gottfred.

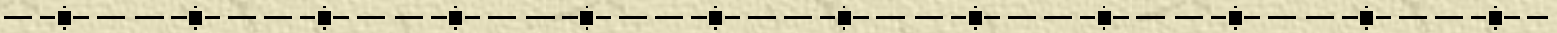



The Author lecturing on Thompson's techniques at Old Fort William. (Photo by A. Gottfred)

Art I. Understanding How Thompson Navigated— Introduction to the Case Study By J. Gottfred.

Introduction

David Thompson is famous for his early exploration and mapping of western Canada and the northwestern United States. From 1790 to 1812, he traveled the Northwest using a sextant and compass to record valuable navigational information. He used this information to make some of the earliest detailed maps of the northwestern U.S. and western Canada. Paradoxically, although his navigational skills gave Thompson his claim to fame, they are poorly understood by both historians and geographers. How did he calculate his latitude and longitude, and how accurate was he? In this issue, I will use examples from Thompson's notes to illustrate and explain the navigational methods that he used.

There are a number of challenges to studying Thompson's navigational methods. The techniques of celestial navigation have changed significantly in the last two hundred years, but there are still a number of common denominators. Marine navigators still rely on sextants today, although there is increasing reliance on other navigational instruments such as GPS receivers. (Sextants are no longer used for land navigation and mapping.) Modern navigators use the Marcq St. Hilaire method, which requires two sextant observations and a highly accurate knowledge of Greenwich Mean Time, to find their latitude and longitude simultaneously. A nautical almanac (ephemeris) provides the positions of the celestial bodies for the current year, in a format designed to be easily used with modern navigational methods. Electronic calculators or tables of pre-calculated solutions are used to simplify the calculations and ensure accuracy. In Thompson's day, finding latitude and longitude were two separate problems, requiring a number of different sextant observations made at different times. A nautical almanac provided the positions of the celestial bodies for the current year, including data on lunar distances for use in determining longitude. A large array of tables such as those in Neville

Maskelyne's *Tables Requisite* (e.g. proportional logarithms, log-trig tables, double altitude tables, etc.) were used to simplify calculations and ensure accuracy.

In this volume of *Northwest Journal*, I present a case study of David Thompson's navigational methods, skill, and accuracy. The case study examines Thompson's journey from Boggy Hall to the Whirlpool River, from October 19, 1810 until January 7, 1811. This is an important period because Thompson was near the end of his fur trade career (he retired in 1812) and had twenty years of navigational experience behind him. He was about to make two of his most important journeys : crossing the Athabasca Pass and descending the Columbia River to its mouth. So it is important to have a baseline appraisal of Thompson's skill, by examining his first few steps along the trail and evaluating his ability to accurately plot his position.

The case study provides an example of each type of sextant observation made by Thompson during this period. I explain the purpose of the observation and show how he used it to help determine his latitude or longitude. In addition, I demonstrate that his 'goods shed' (possibly the first 'Henry House' on the Athabasca) was not located at the south end of Brûlé Lake, contrary to the currently accepted position.

To my knowledge, most of the information presented in these articles has never before been published. Smyth (1981) and Sebert (1981) both discuss methods used by Thompson, but do not seem to be heavily based on Thompson's data ; instead, both authors turn to an examination of methods used by marine navigators of Thompson's time. Stewart (1936) and Smith (1961) compared the accuracy of Thompson's maps to modern maps of the same areas. In his journals, Thompson recorded all the information about his astronomical observations that he would need to re-do his calculations and double-check them at a later date. He also recorded key steps (intermediate solutions) in his calculations. Using Thompson's own data and recomputing his answers step by step, I will show :

—How he periodically recomputed the index error of his sextant, and how

this information can be used to show that the accuracy of his instrument and his observational skill were excellent. ([Article IV](#), p. 15-16).

—How he found his latitude by observing meridian altitudes of the sun, and that the observation made at the 'goods hut' was made using his reflecting artificial horizon and was accurately computed. ([Article V](#), p. 16-17).

—How he found his latitude by double altitudes— observing two altitudes of the sun or other star, separated by a time interval measured on his watch, and how this data can be used to show that Thompson was capable of making highly accurate runs of sight while away from the conveniences of fort life. ([Article VI](#), p. 17-20).

—How he computed Greenwich Apparent Time by observing lunar distances and how lunar distance longitudes can be made by only one person who observes only the lunar distance and the altitude of some other body. I also show that this was the technique actually used by Thompson ([Articles VII](#), p. 21-28, & [Article VIII](#), p. 28-31).

—How, with a knowledge of Greenwich Apparent Time, he computed longitude by observing the sun or another body, how he kept his watch set correctly to local time, and how he computed magnetic declination ('compass variation'). In addition I provide an estimate of the accuracy of his watch and how he used his watch in general. ([Article VIII](#), p. 28-31).

Along with these demonstrations, I also :

— Describe, in general, Thompson's navigational routine and discuss my assessment of his diligence ([Article II](#), p. 4-7).

—Provide guidelines for assessing the accuracy of any position computed by Thompson ([Article II](#)).

—Re-examine the location of the 'goods shed' constructed by Thompson and his men December 5-29, 1810, in the light of the case study ([Article III](#), p. 7-

14).

—Compute a completely new latitude for the goods shed which, in conjunction with Thompson's latitude, demonstrates that the accepted location is incorrect ([Article IX](#), p. 31-34).

—Provide a complete explanation of each kind of notation (including marginal notations) in Thompson's astronomical notes for the period of the case study (*passim*).

—Provide a glossary of navigational terms ([Article X](#), p. 35-37).

It should also be noted that Articles V through IX assume a basic knowledge of modern celestial navigation as used on small boats today. For background information on navigational instruments and the general principles of celestial navigation during Thompson's time, see Gottfred, '[Period Navigation](#)'. More details on Thompson's navigational instruments are in Gottfred, '[Life](#)', p. 3-6, and in Smyth.

Resources

By far the most accessible way for club members to see Thompson's data is through *Columbia Journals*, edited by Barbara Belyea. *Columbia Journals* is an excellent transcription of selections from David Thompson's daily notes from October 1800 to September 1811. Belyea has done an outstanding job of deciphering Thompson's often faint and nearly illegible handwriting, and presenting this information in a clear form true to the original. With this volume, Belyea has made a large portion of Thompson's textual descriptions of where he is and what he is doing available to the reader.

Columbia Journals is not intended to be a complete transcription of all of Thompson's material for this period. Belyea has selected portions of the journals which focus on Thompson's efforts to cross the Rocky Mountains and establish fur posts and trade routes between the Rockies and the Pacific. She omits most of Thompson's navigational information. Consequently, for

the period of the case study, the manuscripts journals contain much additional useful information about all the celestial observations.

For the data presented in this case study, I have used Thompson's course and distance information as it appears in *Columbia Journals*, and his celestial navigation information as it appears in the original manuscripts. A complete list of references and resources is provided at the end of [Article X](#).

Art II. Assessing David Thompson's Surveying Skill— Guidelines for Historians.
by J. Gottfred.

Sloppy...

I have heard comments to the effect that Thompson was a sloppy surveyor. Is this so? In my opinion, for the period of the case study, the answer is yes.

During the period of the case study, Thompson observed eleven lunar distances. He computed nine of these correctly, and in two he either made significant errors in computing the true distance, or he copied down the wrong data.

He incorrectly writes 'N' instead of 'S' for solar declinations four times during this period, but he does not use them incorrectly in his calculations (Nov. 2, 3, 13, 21).

He mis-identifies stars on two occasions and confuses himself to the point that he throws out good data (see Art. III).

At one point he writes down $27^{\circ} 49' 45''$ as $27^{\circ} 29' 45''$, and ruins a day's work before he notices the error. However, he does go back and correct (almost) everything (Art. III).

In his lunar distance calculations he sometimes records right ascensions in hours (which they should be), and sometimes he records the value after he

has converted hours to degrees. Confusingly, he usually fails to note which of these units he is using (p. 23, 24).

Almost every page of computations has values scratched out and changed or written over. In this regard it is not a 'neat' copy.

Thompson does record everything required to go back and recompute his answers at a later date. Every observation has the temperature recorded, as well as each time and altitude pair taken during the run of sights.

It must be remembered that Thompson likely suffered from a shortage of paper, and this is reflected by the fact that many intermediate steps in his calculations are missing from the pages, and the data is crammed into as small a space as possible.

Overall, the notes strike one as being made by an individual for his own use. Certain items which were obvious to the note-keeper have not been recorded for posterity. Anyone viewing this material with an eye to information content for posterity would be justified in calling the work 'sloppy'.

Yet Reliable

Does this mean that Thompson's work is unreliable? In my opinion, no. The information is recorded in a fashion which made sense to the owner. Over the last ten years I have used my own sextant under many different conditions to replicate all of the techniques that Thompson used. I can honestly say that his notes make sense to me, and that his observational skill was probably better than mine. How he records information in his notebooks says nothing about his observational skill and I have found much evidence that his skill was considerable.

Broad-based comparisons made by looking at Thompson's positions compared to modern positions may fail to account for the varying reliability of different observational techniques, and the possibility of errors in calculation. On the other hand, if one takes the time to carefully examine Thompson's observations, to recalculate them to check for errors, to assess

the accuracy of the method used for each observation, and the conditions under which they were made, then error bars may be placed around each observation. In fact, it is even possible to find additional useful data. For example, in the case study I found two additional latitudes which are perfectly sound, and which were helpful in reconstructing his movements ([Article IX](#)). The error-bounded observations should then form the control points through which his course and distance positions must pass.

General assessments of the accuracies of Thompson's observations should be avoided; instead, each observation should be independently assessed. However, if Thompson's calculations are accurate, if a mercury reflecting artificial horizon was used for all observations (except measuring lunar distance), and if the apparent altitudes of the bodies weren't too close to the horizon, then I feel that it should be generally safe to assume that any latitude by meridian transit observation would be correct within 1½ nautical miles, and any latitude from a double altitude observation should be correct to within 2 nm. This is based on my own experience using Thompson's methods in the field.

Synopsis of Thompson's Navigational Routine

Thompson's general routine for determining his position using the sun and the moon (for example) was as follows :

Upon arrival at a new camp, Thompson would try to obtain an accurate latitude. If possible, he would observe a meridian transit of the sun ('noon sight') ([Art. V](#)). If this was not possible, he would make two observations of the sun one hour apart, which he would then use to compute a latitude with the double altitude method ([Art. VI](#)).

If the moon was in a convenient location, Thompson would observe the distance between the moon and the sun ([Art. VII](#)). Then, within half an hour or so, he would observe the altitude of the sun— a 'time shot' ([Art. VIII](#)). When making these lunar distance observations, he checked the index error of his sextant to make sure that it had not changed ([Art. IV](#)).

Using the observed altitude of the sun, the latitude computed earlier, and the declination of the sun as determined from the nautical almanac for the approximate Greenwich time as based on his ded reckoning longitude of the observation, Thompson computed the local apparent time. He then reset his watch to the correct local apparent time. This helped to ensure that he did not miss the next day's noon sight due to the inaccuracy of his watch.

Sometimes, Thompson would note the compass bearing to the sun at the instant of the time shot. From his knowledge of his latitude, the sun's declination, and the observed altitude, he could compute the sun's true bearing (azimuth). The difference between the true bearing and the magnetic compass bearing was the magnetic variation (declination) at his position ([Art. VIII](#)).

From his knowledge of his latitude, the local apparent time, and the declination of the sun, he then computed a close approximation of the sun's altitude at the instant of the lunar distance observation. Then, from his knowledge of the local apparent time, his latitude, the declination of the moon based on his approximation of the time in Greenwich, and the difference in the right ascensions of the sun and the moon at the approximate Greenwich time of his observation, he computed a close approximation of the true altitude of the moon at the instant of the lunar distance observation ([Art. VII](#)).

From the close approximations of the moon's and sun's altitudes, combined with a highly accurate observation of the lunar distance, he then 'cleared the distance' of the effects of refraction and lunar parallax to determine an accurate true lunar distance between the sun and the moon for the local apparent time of the observation. He then used the nautical almanac to determine the apparent time in Greenwich at which the moon would be at the distance that he observed. The difference between his local apparent time and the apparent time in Greenwich, converted to degrees, resulted in his longitude (see [Art. VII](#) & [VIII](#)).

Thompson also used the stars to compute lunar distances and double altitudes. The techniques are generally the same, but with a slight complication for the computation of local apparent time.

Art III. The Location of David Thompson's 'Goods Shed' on the Athabasca River, by J. Gottfred.

The Location of David Thompson's 'Goods Shed'

In December 1810, while preparing for his epic journey over the Athabasca Pass, David Thompson built a 'goods shed' near the Athabasca River in the vicinity of Brûlé Lake (near today's Jasper National Park). Thompson explains why he built the shed in his memoirs :

'...our Guide told me it was of no use at this late season to think of going any further with Horses...but from this place prepare ourselves with Snow Shoes and Sleds to cross the Mountains : Accordingly the next day we began to make Log Huts to secure the Goods, and Provisions, and shelter ourselves from the cold and bad weather...' (Glover, 318)

Thompson and his men built at least two buildings here : a storehouse and a 'meat shed'. They spent December 5-29 at this spot. On December 30, Thompson left the goods shed, leaving behind North West Company clerk William Henry and half of his twenty-four men.

It is generally accepted that this shed was located at the south end of Brûlé Lake (Glover, 318n; Belyea, 253), but the precise location has not been found. Using my knowledge of his navigational methods I have come to the conclusion that the goods shed was actually located approximately three miles up Solomon Creek at the *north* end of Brûlé Lake.

David Thompson's movements from late October to early December, 1810 took him from Boggy Hall to this 'goods shed'. While traveling, he used his compass to note courses and recorded distance measurements. He also made

frequent observations using his sextant. Before trying to follow his trail it is necessary to try to get a feel for the accuracy of these observations.

The course observations can be tricky to interpret. Thompson generally uses a compass to determine his course. His compass readings are magnetic headings, so correcting them for plotting on a modern map requires some knowledge of the magnetic declination of the area as it was in 1810.

(Magnetic declination changes slowly over time as the north magnetic pole wanders.) In this regard I must caution the reader, for *Columbia Journals* contains many declination values which seem to be magnetic declinations. In fact, these values are the declinations of *celestial bodies* (usually the sun) and therefore cannot be used to correct magnetic compass headings. This is a perfectly understandable error for anyone unfamiliar with nautical astronomy.

Thompson confuses matters by occasionally noting solar declinations as north ; these declinations are *south* during the fall and winter months. He does not use them in his calculations as north declinations, and in other places (most notably in the lunar distance calculations) he indicates that they are south declinations. To add to the confusion on this point, the text in *Columbia Journals* has an 'N' after the declination values listed under November 26 and December 6 which do not appear in the manuscript, and an 'N' after the declination for November 28 which is actually an 'S' in the manuscript. (All other declinations in *Columbia Journals* for the period of the case study are correct.)

Incidentally, in Thompson's time, magnetic declination was called 'variation' and that term is used by marine navigators today (Belyea, 183; Bowditch, 85). (For an example of how Thompson differentiates between magnetic and celestial declinations see Belyea, 78.) During the period of the case study, Thompson only records one variation : '22° or 23° East', measured while at the 'Goods Shed'.

Usually what Thompson is recording is a dead reckoning course : an estimated position allowing for deviations around obstructions, minor bends

in the river, &c. What he is really saying is 'we went down this river through a bunch of twists and turns and around a mountain over a distance of maybe ten miles, but I figure that our new position is six miles south west of our last recorded position.' (Modern navigators call this kind of course ded ('deduced') reckoning.) Not only are these bearings his estimate as a navigator, but sometimes he estimates his bearings by the sun rather than using his compass. (Thompson's compass may not be entirely reliable (Bowditch, 9-10)). I generally assume that his courses are correct to within plus or minus twenty degrees.

Thompson estimates his distance traveled, and I usually assume that his distances are accurate to plus or minus ten percent. In the few journeys that I have plotted, I have been impressed by his ability to judge distances. I feel that his distances estimates are more reliable than his course bearings.

The sextant observations are more interesting. The general accuracy of celestial navigation 200 years ago was basically identical to that of today. The tables of astronomical data and physical phenomena required for navigation appear to have been just as accurate as today's. A commander in the Royal Navy in 1899 stated that 'the maximum error of lunar table[s] may now be considered to be 10 seconds' (Sebert, 412). My modern nautical almanac states that the error in the position of *the moon alone* may reach 18 seconds! (United States Naval Observatory (USNO), 261)

The sextants were also just as accurate as modern ones. My modern Astra IIIB sextant reads to 12" of arc and has an accuracy of plus or minus 20". David Thompson's sextant could read to 15" of arc ; I don't know its accuracy. However, my instrument in conjunction with modern tables is *barely accurate enough* to compute longitudes by lunar distance, and my results are generally not as good as Thompson's. Therefore Thompson's instrument and tables must have been at least as good as mine, and probably better. (I have found good evidence to support this by looking at Thompson's index error calculations. See [Art. IV](#)) Thompson's most inaccurate instrument was his timepiece. Accurate chronometers were very expensive, and Thompson did not have one. Instead, he used two or more

'common watches' (pocket watches) with second hands.

Today, navigators can compute both latitude and longitude from a pair of observations. In Thompson's time, due to the lack of accurate watches, latitude and longitude observations were done separately.

The accuracy of any given observation depends upon what type it was. Thompson uses three different techniques for observing latitudes. The first is called a *double meridian altitude* observation, usually of the sun. This means that he is observing the height of the sun when it is at high noon (crossing the meridian), and he is doing it using his *parallel glasses*, a reflecting artificial horizon made by placing a glass cover over a bowl of mercury. ('Double' refers to the fact that the altitude measured with an artificial horizon is twice what would have been measured using a sea horizon.) Using the same techniques today, I generally compute latitudes to an accuracy better than half of a nautical mile. (1 nm = 1852 meters). On good days my accuracy is within 300 meters. Based on my comparisons with David Thompson's data from Rocky Mountain House, as well as the data in the case study, I feel that for any of Thompson's double meridian altitude observations it is reasonable to assume that his observation would place him within 1½ nautical miles of his true latitude.

Thompson sometimes mentions a second type of latitude observation which he calls a *meridian altitude*. This is an ambiguous term. In most cases, it means that he made the observation using his artificial horizon, but in some cases it means that he has used a local body of water as an artificial horizon. This technique involves using the far shore of a lake or long river as a level, and estimating the distance to the far shore. The navigator then applies a correction to the observation based on this estimate. This technique is more properly known as the *dip short* method. It is far less reliable than using an artificial horizon because of the difficulty of accurately estimating the distance to the far shore. Thompson did not make any dip short observations during the case study period.

The third method of observing for latitude is called a *double altitude*

observation. This means that the navigator has made two observations of the same celestial body from the same position, separated by a time interval measured on a common watch. The idea is that the common watch, although not accurate enough to keep time over several days, is accurate enough to keep the time for about an hour. This means that two observations of the same star, separated by a known time interval, allow the navigator to compute his latitude directly using spherical trigonometry. The accuracy of this method depends upon a few variables. First, if both observations were made using an artificial horizon then the results can be very accurate. If one or both observations used the dip short method, then the result will be fairly suspect. For observations made using an artificial horizon and from one to two hours apart, it should be safe to say that the accuracy of the observation would be plus or minus two nautical miles.

Finding longitude involves making highly accurate observations of lunar distances. Thompson makes eleven observations for longitude at three locations during the period of the case study. The method which he used is fully explained in articles VI and VII. Unfortunately, the accuracy of lunar distance longitudes is poor at best. In general, any single observation will be *no better than* $\pm 20'$ of longitude. If more observations from the same spot are averaged together, the result will be more reliable. More than a dozen observations must be averaged together to obtain accuracies within four or five minutes of longitude. During the period of the case study Thompson does not stay in one spot long enough to observe enough longitudes to pin his location down to better than $\pm 20'$ of longitude.

Thompson's Trail

I began by tracing Thompson's route from a position near the Athabasca River on November 26, 1810 (Belyea, 125). On that day, Thompson and his party camp at 12:15 p.m., and Thompson soon makes a double altitude observation. He computes a latitude of $N53^{\circ} 30' 39''$. The next two day's travels take him northwest around a 'long lake' and along a brook to near the Athabasca River. On November 28, he observes a double meridian altitude of the sun and computes a latitude of $N53^{\circ} 37' 54''$. There is no reason to

suspect that either latitude would be farther than 2 nm from his actual position. In his November 27 journal entry, he draws a picture of the 'long lake'. It seems clear that this lake is Summit Lake, and the creek that they followed to the Athabasca River is Obed Creek.



Summit Lake— David Thompson's drawing of the lake they passed on November 27, 1810. It seems clear that this is Summit Lake. Obed Creek is shown emerging from the north west corner of the lake.

Thompson then begins to ascend the Athabasca, and on November 29 they camp near a large island in the river ($\frac{3}{4}$ mile long.) River islands are usually poor landmarks, since they erode rapidly, but this island would probably be big enough to persist. Such an island appears on my topographic map within one statute mile of where Thompson's course and distance information would place him on November 29. This camp would be on the Athabasca River at about N53° 31'.

The next day, Thompson continues up the river. A position for his camp based on his course and distance information on November 30 would be one mile north of the river at the junction of the Athabasca River and Maskuta Creek. This position tallies with his description : 'the river run around a large Point & is dist from our road thro' the Willow Plain & from the camp at abt 1M' (Belyea, 127). The Athabasca runs fairly straight up to this point, where it begins a series of curves into the mountains.

On the evening of November 30 he makes observations for latitude and longitude. He chooses the star Procyon for his longitude calculation. Unfortunately this star was still below the horizon when he made his

observations! I suspect that he confused the star Pollux with Procyon. He notes in his journal that he has observed the 'wrong star.' On the evening of December 1, while at the same camp, he tries once more but again throws out the data noting 'wrong star'. (There is another possible explanation—perhaps he didn't *observe* the wrong star, perhaps he *used* the wrong star. Thompson's nautical almanac may not have included lunar distance tables for another star he observed that night, Algenib, making the observation useless.) Two of the December 1 observations are of Aldebaran. I find it hard to imagine how Thompson could mis-identify this very bright (magnitude one) *red* star. The altitude that Thompson measures for the star is very close to what it should be for Aldebaran on that date and time. For these reasons, I think Thompson correctly identified Aldebaran. I see nothing else wrong with this Aldebaran observation. When I recompute it, I obtain the result N53° 25' 10". (Thompson calculated N53° 23' before throwing out all of his data for that night.) This latitude lies right on the spot that I obtain by plotting Thompson's course and distance information. I see no reason to think that it is not very close to the actual position.

On December 2 they set out again. It is at this point that I feel Thompson's course diverges from the accepted one. Belyea states that he follows Maskuta Creek to the south end of Brulé Lake (253). However, Thompson says that they traveled south 1 mile to the bank, then southwest through plains and over brooks, and at the end of the day they had gone about 6 miles 'going to the right in curves' and the river was about one-third of a mile away. I feel that this indicates that they followed the course of the Athabasca River, not Maskuta Creek.

They then set off towards the southwest, and met up with the banks of the river, which they followed. They continued southwest until they reached 'the entrance to the Flats which appear like a Lake' (Belyea, 129). I believe that this is the north end of Brulé Lake. Here they met some hunters, who took them to a Native hut on the lake. To get to this hut, they traveled *southwest*. I believe that they were traveling along the northwest shore of Brulé Lake. My estimate of their position would place them at modern-day Swan Landing. It may be significant that this spot is a hamlet today, as places where people

meet tend to persist.

Thompson says that the hunters' hut was small and dirty, and there was no grass for the horses, so they moved the next day. He says that they went north-northwest about 5 miles through aspen forest and camped 'near a small Fountain of Water amongst Pines & Aspens' (Belyea, 129). This is where they decided to build the 'goods shed'.

If they were at Swan Landing on the northwest shore of Brûlé Lake the previous day, then Thompson's course and distance information would suggest a position for the hut somewhere up Solomon Creek at about N53° 23', Lo. 117° 53' W. (Solomon Creek flows southeast before emptying into the northwest end of Brûlé Lake.) I should note here that, although Thompson travels along Brûlé Lake, he doesn't say he is on or near a lake. This is likely because Brûlé Lake is very shallow, and would be at low water and frozen in December. Later, he does not mention the larger Jasper Lake. Both of these lakes are really just widenings in the river.

On December 6, Thompson records a double meridian altitude of the sun, giving a latitude of N53° 23' 27", which is less than one nautical mile from the course and distance position. By examining Thompson's observations from the previous evening, I realized that I could use his observations of the stars Capella and Vega to compute a new latitude using the double meridian altitude method (see [Art. IX](#) for details). The position that I obtain is N 53° 21' 22", or two nautical miles from Thompson's December 6 position. Both of these two latitudes are about eight nautical miles from the south end of Brulé Lake, and effectively rule out that position as the location of the goods shed.

This brings us to a possible error. Thompson compiled a table of observations which is reproduced in Belyea (314). Under December 1-6 he made the note 'Athabasca River, at the Shed Depot of Goods (Longitude of 4 observations)' and gives the position N53° 33' 33" Lo. 117° 36' 34". This latitude seems quite wrong. Where did it come from?

On December 6, Thompson incorrectly copies the value 27° 49' 45" as

27° 29' 45". This causes him to compute a latitude for the goods shed of N53° 33' 33". He then seems to catch the error, and changes the copy to reflect the correct latitude. The incorrect value must have been copied to another journal or log and not corrected.

The reader might be tempted to dismiss *all* of these calculations due to the seemingly large number of errors that I have described. To do so would be a mistake. I have recalculated Thompson's observations and, except as noted, they are correct. Also, an error of this sort is relatively easy for the navigator to catch, as Thompson did, because it gives a result that is markedly inconsistent with the other observations. I see nothing in the journals to indicate that the other values are not reliable. With the corroborating evidence of the newly computed latitude, I feel confident Thompson's value of N53° 23' 27" is within 1½ nm of his actual position.

If we assume that the goods shed is on Solomon Creek, then is this consistent with an analysis of his journey to the Whirlpool River? I believe that it is. They departed the goods shed on December 30 and traveled southeast for five miles. Yet the Athabasca flows *southwest* from the south end of Brulé Lake. It would seem that they were actually traveling back to the north end of Brulé Lake. As mentioned earlier, Thompson does not describe this place as a lake, but as 'full of small Flats & Isles', in other words, a braided stream. His courses from here to the Whirlpool are not very accurate. This may be explained by the fact that on December 31 he gives an approximate course as judged by the sun. Again, I think taking his course directions too literally would be a mistake.

However, there is a good way to judge whether or not a hut position on Solomon Creek is plausible, and that is to look at the distance traveled. Between December 30 and January 7 (arrival at the mouth of the Whirlpool), Thompson notes distances traveled, generally over good ground and in straight lines. They total 54½ miles. The distance from the proposed position of the hut on Solomon Creek to the mouth of the Whirlpool River is about 50 miles. This is about a 10% error on Thompson's part, which is consistent with his ability to judge distances over good ground.

If the goods shed was located at the south end of Brulé Lake, then the actual distance from the hut to the mouth of Whirlpool River would be about 39 miles. Thompson's journal says he traveled 54½ miles. This is about a 30% error, which strikes me as being an unreasonably large error given the skill of the navigator and the type of terrain that he is covering. It is also inconsistent with the accuracy of the distances stated by Thompson on the first part of this journey.

In summary, the latitude listed in Thompson's table for the 'goods shed' is erroneous, and should be discarded. In addition, I suggest that a position for the 'goods shed' approximately three miles up Solomon Creek is consistent with the navigational information supplied by Thompson.

Art IV. Using David Thompson's Sextant Index Error to Show his Diligence and High Accuracy. By J. Gottfred.

The index error of a sextant is a correctable instrument error. Index error is caused by the sextant mirrors being not quite parallel, a normal condition for sextants even today. The navigator can easily determine this index error and correct for it in calculations by observing a distant star and noting what the instrument reads when the star images are properly aligned. In a perfectly tuned instrument, the angle should be zero, but most sextants will show a small positive or negative angle which must then be applied to every observation made with that instrument. The index error should also be monitored with every observation and periodically recomputed to ensure that the mirrors have not been bumped in transit &c. Failure to note the correct index error or to notice a change in the value over time is the most likely way for a systematic observational error to result in positions which are many nautical miles in error. On November 3, 21, and 26, David Thompson makes marginal notations in his calculations which clearly show that he is checking his index error on a regular basis, and modifying its value over time as the instrument reacts to the rigors of travel and changing climactic conditions.

David Thompson's journal entry for November 3, 1810 has an excellent example of an index error calculation which also demonstrates just how accurate his eye and his instrument are. In the corner of the page he makes the notes shown in the box at the right.

Thompson is using the sun to compute the instrument's index error. He does not do this by superimposing the two sun images as one does with a star. This is because the sun is not a point source of light, and judging when the two sun images are precisely overlapped is difficult. To obtain the maximum accuracy, Thompson first aligns the bottom of the sun image with the top and records a measurement of 35' 52". He then reverses the sun images and records 28' 45". Note that the second measurement is actually a negative measurement. He sums the two numbers and then takes their difference, which is 7' 7". He divides the difference by two in order to compute the index error for the center of the body, with the result of 3' 34". Noting that this is a positive value (on the arc), and therefore he must subtract this value from any observation that he makes, he records his instrument error correction as -3' 34", the value he actually uses.

By summing the two values he obtains 64' 37". Dividing by two will yield the sun's diameter. Dividing by two once again yields the sun's *semi-diameter*, 16' 9.4" (or 16.16'). Semi-diameters for the sun for each day are listed in the nautical almanac, because they change gradually throughout the year, as the earth revolves around the sun.

The following table lists sun semi-diameters computed from Thompson's index error notes for the period of the case study (rounded to the nearest 0.1') compared to the actual values of the sun's semi-diameter for those dates, as listed in a 1996 nautical almanac.

Date	DT's S.D.	Actual S.D.
Nov. 3, 1810	16.2'	16.2'

Nov. 21, 1810 16.2' 16.2'

Nov. 26, 1810 16.3' 16.2'

Note that the almanac only gives values to the nearest 0.1' as this is the limit of the resolution of the eye. (This limit corresponds to a maximum theoretical accuracy of 185 meters on the ground.)

This demonstrates that Thompson and his instrument can measure the semi-diameter of the sun to an accuracy of 0.1 of a minute. Because this process is visually identical with actually making an altitude observation using a reflecting artificial horizon, this also demonstrates that both Thompson and his instrument were capable of measuring the height of the sun to an accuracy of 0.1'.

Art V. Recomputing Thompson's Data— Latitude by Double Meridian Altitude.
By J. Gottfred.

On December 6, 1810, while at the 'goods shed', Thompson records the following information :

Thompson is saying that he has observed a meridian altitude of the sun's lower limb to determine his latitude, and that the sun's declination was 22° 30' 50" when he made the observation at 7 hours 48 minutes Greenwich Time by his watch. (The astronomical day started at noon in Thompson's time (Belyea, 274)). On December 6, local apparent noon at Brûlé Lake would be about 19:48 Greenwich Time.

A meridian altitude of the sun ('noon shot') is still used by navigators at sea to determine latitude. When an artificial horizon is used, this type of observation may be called a *double* meridian altitude, because the angle measured by the sextant is twice what it would have been if a sea horizon had been used.

We can use the data given by Thompson to recompute a latitude for his position (Thompson's data in italics) :

27° 49' 45" Height of sun times 2 (artificial horizon),
-3' less index correction (see [Art. IV](#)),
27° 46' 45" gives corrected height of the sun.
13° 53' 22" Divide by 2 to get height of the sun,
-3' 48" less refraction of the air correction (ignore *f*),
13° 49' 34" gives height of sun corrected for refraction.
+16' 18" Adding semi-diameter of sun for Dec. 6
14° 5' 52" gives height of the sun as observed.
90° 0' 0" Angle between the zenith and horizon,
14° 5' 52"– less the height of sun,
75° 54' 8" gives zenith distance.
22° 30' 50"– Subtract south declination of sun for
53° 23' 18" final latitude.

(Please note that 'height of the sun' is height of the sun above the horizon.)

This latitude differs from Thompson's by only 9 seconds, or 278 meters on the ground. Since I don't know what Thompson used as a refraction coefficient (*f*) to correct for local density altitude, the answers are essentially the same.

This example clearly shows that Thompson used a reflecting artificial horizon for this observation and that he did not make any mathematical errors in calculating this

latitude.

Art VI. Recomputing Thompson's Data— Latitude by Double Altitudes. By J. Gottfred.

On November 3, 1810, David Thompson records some observations which were used to compute latitudes by double altitude. In this article, I present an example calculation for latitude using Thompson's data. Note that I will show a mathematical technique for computing the latitude which illustrates how it is done. Thompson would have used tables to simplify his calculations.

Thompson's first observation is an upper limb observation of the sun (Thompson's data in italics) :

<i>0h 33m 53s</i>	<i>43° 44' 0"</i>	
<i>0h 34m 41s</i>	<i>43° 42' 0"</i>	
<u><i>0h 35m 27s</i></u>	<u><i>43° 40' 0"</i></u>	
<i>0h 34m 40s</i>	<i>43° 42' 0"</i>	Average of values,
	<u><i>-3' 34"</i></u>	less index correction,
	<i>43° 38' 26"</i>	gives Hs x 2 corrected.
	<i>21° 49' 13"</i>	Divide by 2 to find Hs.
	<u><i>-2' 30"</i></u>	Less refraction correction.
	<i>21° 46' 43"</i>	Corrected for refraction.
	<u><i>-16' 12"</i></u>	Less semi-diameter of sun
	<i>21° 30' 31"</i>	Height observed #1 (Ho1)

The reason for averaging the time and sextant readings is that the average

values will fall on a line which is the best fit through all three observations. Thompson provides a second run of sights roughly an hour later :

<i>1h 30m 54s</i>	<i>39° 25' 45"</i>	
<i>1h 31m 37s</i>	<i>39° 21' 30"</i>	
<u><i>1h 32m 21s</i></u>	<u><i>39° 16' 0"</i></u>	
<i>1h 31m 37s</i>	<i>39° 21' 5"</i>	Average of values,
	<u><i>-3' 34"</i></u>	less index correction,
	<i>39° 17' 31"</i>	gives Hs x 2 corrected.
	<i>19° 38' 46"</i>	Divide by 2 & find Hs.
	<u><i>-2' 48"</i></u>	Less refraction correction
	<i>19° 35' 58"</i>	Corrected for refraction.
	<u><i>-16' 12"</i></u>	Less semi-diameter of sun.
	<i>19° 19' 46"</i>	Height observed #2 (Ho2)

Thompson notes the declination of the sun at the time of the first observation is $15^{\circ} 4' 20''$ south. I computed a declination at the time of the second observation based on the rate of change in the sun's declination for this time of the year as follows :

The difference in time between the first and second observations is 56m 57s. The rate of change in the declination of the sun is $44''$ per hour on this day of the year, so the declination for the second observation would be $15^{\circ} 5' 2''$ S.

We now convert the time difference between the two observations (56m 57s) to arc in order to find the meridian hour angle t (See figure 1). By dividing the time interval by 4 minutes per degree of longitude, we can express angle t in degrees, and so we find that t is $14^{\circ} 14' 15''$.

Find d

Now find *d*. For all of the following computations we will use the law of cosines for spherical triangles. It states that for any spherical triangle XYZ, consisting of sides of length *x*, *y*, *z* :

$$\cos X = \frac{\cos x - \cos y \cdot \cos z}{\sin y \cdot \sin z}$$

Therefore, substituting for the triangle Pn-Sun1-Sun2

$$\cos t = \frac{\cos d - \cos PD1 \cdot \cos PD2}{\sin PD1 \cdot \sin PD2}$$

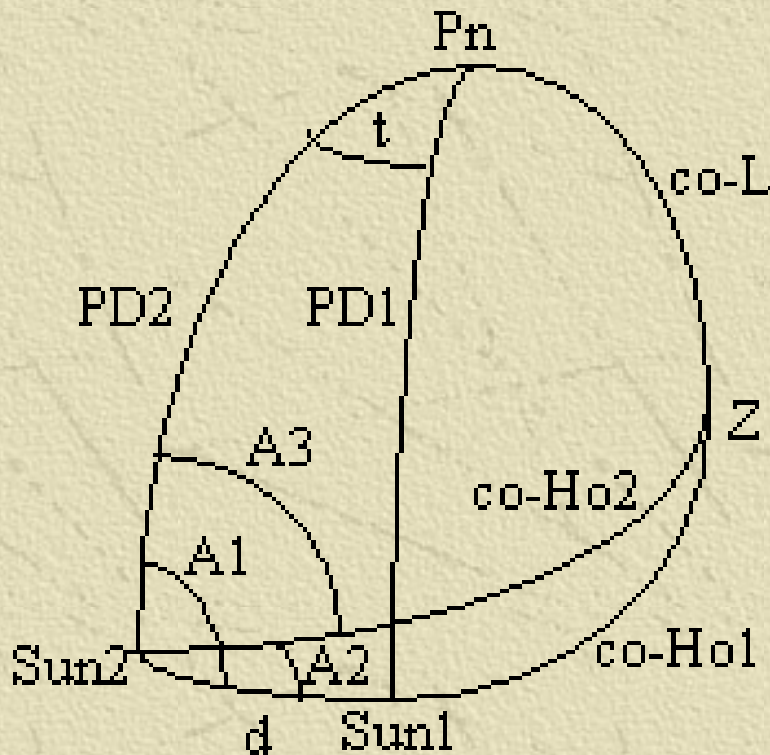

Figure 1 — The line segments connecting the points are all great circles on the surface of the earth. **Pn**— The north pole. **Z**— The observer's zenith, **Sun1**— the geographical position (GP) of the sun at the time of observation #1. **Sun2**— the geographical position of the sun at the time of observation #2. **t**—the meridian hour angle between Sun1 and Sun2. **PD1**— The polar

distance of the sun at the time of observation #1. **PD2**— The polar distance of the sun at the time of observation #2. **d**— The distance between the GP's of Sun1 and Sun2. **co-L**— the observer's co-latitude (90° - latitude). **co-Ho1**— The co-height of the sun measured by observation #1. **co-Ho2**— The co-height of the sun measured by observation #2. **A1**— Angle Pn-Sun2-Sun1. **A2**— Angle Z-Sun2-Sun1 **A3**— Angle Pn-Sun2-Z.

We note that the polar distances PD1 and PD2 are the sum of 90° plus the declinations of sun declinations 1 and 2 respectively. Solving, we find $d = 13^\circ 44' 44.6''$

Find A1

The next step is to find the angle Pn-Sun2-Sun1. Again, from the law of cosines for spherical triangles we can write:

$$\cos A1 = \frac{\cos PD1 - \cos d \cdot \cos PD2}{\sin d \cdot \sin PD2} \quad \text{Solving, we find } A1 = 91^\circ 48' 45.0''$$

Find A2

Next, we find the angle Z-Sun2-Sun1 in spherical triangle Z-Sun2-Sun1. Once again we use the law of cosines for spherical triangles to write:

$$\cos A2 = \frac{\cos(\text{co_Ho1}) - \cos(\text{co_Ho2}) \cdot \cos d}{\sin(\text{co_Ho2}) \cdot \sin d}$$

Because $\sin x = \cos(90^\circ - x)$ and $\cos x = \sin(90^\circ - x)$:

$$\cos A2 = \frac{\sin Ho1 - \sin Ho2 \cdot \cos d}{\cos Ho2 \cdot \sin d} \quad \text{Solving, we find } A2 = 78^\circ 23' 26.2''$$

Find A3

Now we find the angle Pn-Sun2-Z in triangle Pn-Sun2-Sun1 by simply subtracting A2 from A1:

$$91^{\circ} 48' 45.0'' - 78^{\circ} 23' 26.2'' = 13^{\circ} 25' 18.8''$$

Find L

Finally, we find the latitude, L. Once again from the law of cosines for spherical triangles we can write:

$$\cos A_3 = \frac{\cos(\text{co}_L) - \cos(PD_2) \cdot \cos(\text{co}_{Ho_2})}{\sin(PD_2) \cdot \sin(\text{co}_{Ho_2})}$$

Using the same trigonometric rules earlier we can write:

$$\cos A_3 = \frac{\sin L - \cos PD_2 \cdot \sin Ho_2}{\sin PD_2 \cdot \cos Ho_2}$$

Rearranging, we get:

$$\sin L = \cos PD_2 \cdot \sin Ho_2 + \sin PD_2 \cdot \cos Ho_2 \cdot \cos A_3$$

Solving, we find $L = 53^{\circ} 8' 22''$.

This value for L differs from Thompson's computation ($53^{\circ} 7' 57''$) by only 25". This deviation is easily explained by the fact that we did not use exactly the same declination as Thompson, nor did we apply the refraction correction coefficient f , nor did we account for Thompson's watch error rate. Even so, this nearly identical result clearly shows that Thompson was using his reflecting artificial horizon for these observations, and that his calculations are correct.

Upon recalculating three possible latitude pairs for observations on that day which are separated by up to 2h 28m I found the mean value to be $53^{\circ} 8' 36'' \pm 26''$. This is only ± 0.4 nm, which is excellent shooting for double altitude observations, and demonstrates that Thompson was able to accurately measure the sun's changing altitude over the course of three hours while away from the conveniences of fort life.

Art VII. Recomputing Thompson's Data— Greenwich Apparent Time by Lunar Distance. By J. Gottfred.

On November 21, 1810, David Thompson recorded three lunar distance observations in order to determine Greenwich Apparent Time (GAT). He needed to know GAT time, in conjunction with local time, to compute his longitude (see [article VIII](#) for details).

Observing the motion of the moon to compute the time in Greenwich, England is based on the fact that the moon's proper motion relative to the stellar background is about 30' of arc per hour. This means that in about 12 seconds of time the moon will move far enough, relative to another object on the ecliptic, for the distance it moved to be measured. Since the moon's motion is predicted with high accuracy in the nautical almanac, this means that in theory an observer could determine at what GAT time the moon would be seen at the observed distance to an accuracy within 12 seconds of time. This would allow the observer (in conjunction with another observation) to compute a longitude to a theoretical accuracy of about 3'. In practice, accuracies of $\pm 20'$ are all that can be achieved. However, several observations taken from the same place and averaged together can yield significantly higher accuracy.

Although the basic idea is simple, it is complicated by the distorting effects of the refraction of the earth's atmosphere. The refraction and parallax corrections for an observation taken perpendicular to the earth's surface are easily obtained from tables. However, lunar distance observations cut across

the sky at oblique angles, and computing the effects of refraction and lunar parallax are more challenging. Correcting for these effects is called 'clearing the distance', and an example of Thompson's method is given below.

Contemporary books describing lunar distance observations for mariners recommended that four observers and three sextants be used to obtain the maximum accuracy. One observer measured the distance between the moon and another object on the ecliptic, another observed the altitude of the moon above the horizon, a third observed the height of the second body above the horizon, and the fourth called out the time so that all these observations could be made simultaneously.

Thompson worked alone (he only had one sextant), so how he could have made these observations has been a puzzle. In his article on Thompson's method for longitude, Sebert notes that :

'On smaller ships, and in Thompson's case, it was the custom for one observer to read all the angles, assisted only by a locally trained timekeeper. The readings, in the order taken, were the air temperature (for calculating refraction), the moon's elevation and time, the star's elevation and time, the lunar distance and time, the star's elevation and time, and the moon's elevation and time.' (Sebert, 408. cf. Garnett, 31-32.)

Smyth also mentions this method (Smyth, 14-15).

All of these observations should be made as quickly as possible. The idea is to determine the rate of change in the lunar and stellar altitudes, and compute what their altitudes would have been at the instant of the lunar distance observation.

I have used this technique myself and it works admirably. However, David Thompson, although diligently recording all other observations, makes no such 'bracketing observations' of his lunar distances. In fact, for the period of the case study he never observes the moon's elevation at all. In short, Thompson's journals for the period of the case study do not show that he made his longitude observations in the manner Sebert & Smyth both suggest.

The solution to this puzzle is found in Thompson's marginal notes for each lunar distance that he observes. For each distance observation, he notes the right ascension of the sun and moon, as well as their declinations. This information is not required for clearing a distance if the altitudes have been observed. If, however, the altitudes of the moon and second celestial body have *not* been observed, then they can be calculated from knowledge of the observer's known latitude and estimated longitude, using the right ascensions and declinations given in the nautical almanac for the approximate GAT of the observation.

At first glance this may seem like a paradox— if Thompson knows where he is then why is he trying to figure out where he is? It is important to understand that Thompson knows where he is within some ever-widening circle of uncertainty. The object of all of these observations is to refine this estimate of his position and shrink the circle of uncertainty. After all, the art of navigation is the art of staying found.

The mathematics of clearing lunar distances seem to be quite tolerant of errors in the computed altitudes of the moon and second body. What is critical is that the distance between the two be measured with high accuracy. Some preliminary calculations that I have done suggest that as long as his dead reckoning longitude was correct to within 30', it makes little or no difference to the cleared distance. However, more study is required before this figure can be accepted.

Sebert notes that this method was used in Thompson's time :

'...in the more advanced navigational texts there is a method given for the case where the horizon cannot be seen and only the lunar distance is read. The solution involves first calculating the true altitude of the two bodies, and then applying the corrections for refraction and parallax in reverse. It is a very long problem.' (Sebert, 412)

This was exactly what Thompson was doing for every lunar distance I have

examined, yet Sebert does not seem aware of Thompson's use of this method. (Readers of Sebert's paper should know that he makes a couple of minor errors in his calculations. On p. 409, he renders $51^{\circ} 28' 35''$ as 51.4676° . The correct value is 51.4764° . The moon's refraction on p. 410 is $4' 20''$ which is $4.33'$, not $4.2'$. These early errors throw off Sebert's calculations for both examples as well as his conclusion. The answer obtained using Borda's method should give the same result as using Young's formula given at the end of this article.)

On November 21, 1810 Thompson observes a lunar distance between the sun and the moon's near limbs. In the margin he notes the following information :

H ' "

α 's AR [sun's right ascension]— 15 .. 46 .. 16

Dec [sun's declination] — 19 .. $54\frac{1}{2}$ S

β 's AR [moon's right ascension]— 176 .. 15 .. 15

Dec [moon's declination] — 57 $1/6'$ N

S.D.[moon's semi-diameter]— 15' $9\frac{1}{2}''$

HP [moon's horizontal parallax]— 55 .. 37

α 's TA [sun's true altitude]— 11 .. 44 .. 9

α 's AA [sun's apparent altitude]— 11 .. 48 .. 50

β 's TA [moon's true altitude]— 32 .. 20 .. 53

β 's AA [moon's apparent altitude]— 31 .. 35 .. 10

TD [true lunar distance]— 62 .. 32 .. 36

$$+ 2-5 + 2-20 + 9''$$

117° 13' W

Thompson lists these values using little abbreviated symbols, the meaning of which should be clear if you know what the abbreviations are. All of the values are actually in degrees, minutes, and seconds of arc except for the sun's AR which is in hours, minutes and seconds of time. The moon's HP is in minutes and seconds of arc. Of these values, the AR, dec, and HP values come from the nautical almanac. The moon's S.D. may have come from the almanac, or may have been computed using the standard formula $S.D. = 0.2724^\circ * HP$. The values for the true altitudes of the sun and moon would have been computed by Thompson in the following manner :

From his observation of the altitude of the sun taken fifteen minutes after the lunar distance observation, Thompson would have computed the local apparent time as described in Article VIII. The only information he needs to compute the local apparent time is his ded reckoning longitude and his latitude, which he determines using one of the latitude methods discussed previously. From his dead reckoning longitude he determines the approximate time in Greenwich. For example, if he assumed that he was at Lo. 116° 30' W, then at 15° per hour, he would be 7 hours 46 minutes behind Greenwich. Knowing the approximate time at Greenwich allows him to compute the declination of the sun from the information in his nautical almanac. Using the declination of the sun (d) and his latitude ($L = 53^\circ 24' 52''$), as well as the height of the sun above the horizon (H_o) that he observed, he computed a local apparent time of 22h 9m 31s for his 'time shot' (see [Art. VIII](#)). Using the difference in his watch time between the lunar distance observation and the time observation, he now knows the local apparent time of his lunar distance observation, in this case 21h 53m 15s. Remember, Thompson is using astronomical time, so this corresponds to 9h 53m 15s a.m., or 2h 6m 45s before noon, local time. At 15° per hour, this means that the sun's meridian angle (the angular distance from noon at Thompson's position) is 31.6875° . Thompson now knows his latitude (L), the polar

distance of the sun ($PD = 90^\circ + \text{declination}$), and the meridian hour angle (t). This allows him to compute the apparent altitude of the sun at his location at the instant of the lunar distance observation using the formula:

$$\sin Ho = \cos PD \cdot \sin L + \sin PD \cdot \cos L \cdot \cos t$$

In this case, I compute a true altitude for the sun of $11^\circ 44' 17''$. The $8''$ difference from Thompson's value is probably explained by his use of tables to compute the result.

He then computes the true altitude of the moon. Again, he knows his latitude (L), and he can find the declination of the moon from the nautical almanac for his estimate of the time at Greenwich. To find the meridian hour angle (t) of the moon, he needs the right ascensions of both the sun and the moon. Again, he gets these from the nautical almanac for the approximate GAT time of his observation. The difference in the right ascensions of the sun and the moon tell him the meridian hour angle between the sun and the moon, in this case $4\text{h } 1\text{m } 15\text{s}$. At 15° per hour, this is 60.3125° . Incidentally, the moon's AR is really $11\text{h } 45' 1''$, but Thompson writes $176 \dots 15 \dots 15$. This is because he has already converted it to degrees.

The sun was not yet at Thompson's meridian, but the moon has already gone by. This means that the moon's meridian hour angle will be 60.3125° minus the sun's meridian hour angle of 31.6875° . The answer I get is 28.625° .

Plugging these values into the formula above yields a true lunar altitude of $32^\circ 26' 33''$. This differs from Thompson's answer by $5' 39''$. (For some reason, all of my recomputed lunar true altitudes for this day differ from Thompson's by about $5' 40''$.) However, this is sufficiently close to Thompson's answer that it seems clear that this is the method that he was using.

Calculating Apparent Altitudes

Now that Thompson has calculated his true altitudes from his dead reckoning position, he calculates the apparent altitudes from the true altitudes. First he calculates the apparent altitude of the sun.

$11^{\circ} 44' 9''$ S (computed by Thompson),
 $+4' 31''$ plus refraction correction,
 $11^{\circ} 48' 40''$ gives s— apparent altitude of sun.

This differs from Thompson's value by $10''$. Next, we want to find the moon's apparent altitude. However, before we proceed, we must compute the moon's parallax in altitude (PA), which is the cosine of the apparent altitude, times the horizontal parallax (HP). The value I obtain is $46' 59''$.

$32^{\circ} 20' 53''$ M (computed by Thompson),
 $-46' 59''$ less PA,
 $+1' 30''$ plus refraction correction,
 $31^{\circ} 35' 24''$ gives m— apparent altitude of moon.

This differs from Thompson's value by $14''$. The small difference notwithstanding, these examples demonstrate how apparent altitudes can be computed from the true altitudes. For the rest of the example, I will use Thompson's apparent altitudes so that the final answer can be compared to his.

Finding Apparent Distance—d

The first step in clearing the distance is to find the apparent distance, d , between the moon and another celestial body (sun, star, or planet). (See fig. 1). Thompson has measured the distance between the nearest limbs (edges) of the sun and moon to be $62^{\circ} 0' 5''$, so this value must be corrected for the semi-diameters of both bodies to find the distance from center of body to center of body. This is computed as follows (Thompson's data in italics):

$62^{\circ} 0' 5''$	Average observed in sight run,
$-3' 34''$	less index error correction, gives
$61^{\circ} 56' 31''$	actual angle measured to near limbs.
$+15' 9''$	Add moon's semi-diameter (S.D.) and
$+16' 12''$	add sun's S.D. for date, for
$62^{\circ} 27' 52''$	d— the apparent distance.

Thompson does not record this value in his notes. Nor does he note any d values for any of his lunar distances.

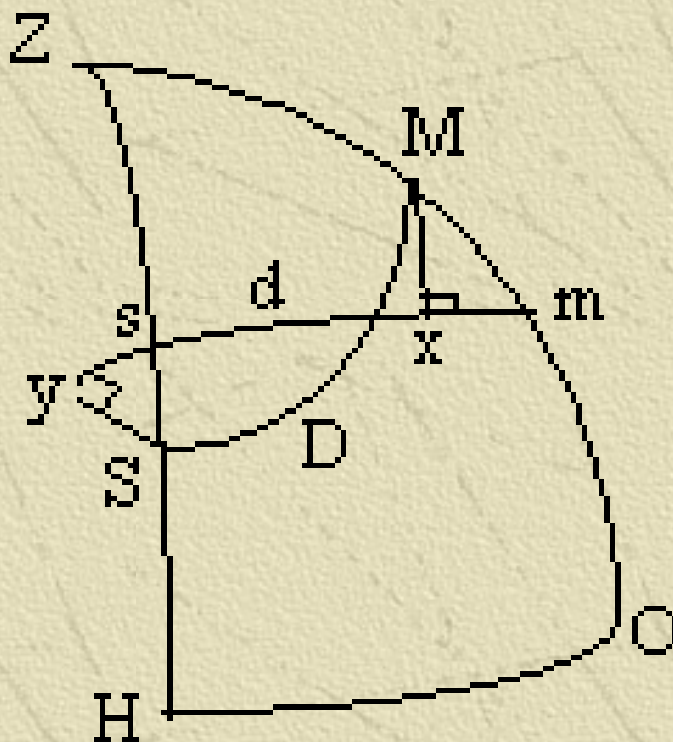

Figure 1 — Clearing the distance. **Z**— observer's zenith. **HO**— The observer's horizon. **M**— the true altitude of the moon's center. **m**— The apparent altitude of the moon's center. **S**— The true altitude of the sun's center. **s**— The apparent altitude of the sun's center. **D**— Line SM, the true distance between the sun and moon's centers. **d**— Line sm, the apparent distance between the sun and moon's centers.

The Approximation Method

Thompson uses an approximation method to determine a solution to the distance d . The answers should not materially differ from computations using a more rigorous method, and in Thompson's day they were much easier to perform.

Referring again to figure 1, perpendiculars (xM and yS) are drawn from the line connecting ms to the true positions M and S . The idea is that the distance xy is a close approximation to the distance MS . Angles y and x are 90° , and their sides are so small that they can be treated as plane triangles for the purposes of finding the lengths of xm and ys . We can now solve the spherical triangle sZm and compute the angles at m and s . (note that Zsm and YsS are congruent).

Thompson provides the following data :

Finding Angles m and s

The first step is to find the value of angle m . For all of the following computations we will use the law of cosines for spherical triangles (see Art. VI). Using this formula for triangle sZm we can write :

$$\cos \angle m = \frac{\cos(90^\circ - s) - \cos(90^\circ - m) \cdot \cos d}{\sin(90^\circ - m) \cdot \sin d}$$

$$\cos \angle m = \frac{\sin s - \sin m \cdot \cos d}{\cos m \cdot \sin d}$$

Solving, we find angle $m = 92.8388^\circ$. Similarly we can write:

$$\cos \angle s = \frac{\sin m - \sin s \cdot \cos d}{\cos s \cdot \sin d}$$

Solving, we find
 $s = 62.4644^\circ$

Finding Segments xm and ys

The line segments xm and ys can be found from plane trigonometry.

$$\cos \angle m = \frac{xm}{M - m}; \cos \angle s = \frac{ys}{S - s} \quad \begin{array}{l} xm = 2' 16'' \\ ys = 2' 10'' \end{array}$$

From figure 1 it can be seen that if angle m is less than 90° (acute), then the length of line segment xm should be *subtracted* from d. If it is greater than 90° (obtuse), then it should be *added* to d. If angle s is less than 90° (acute), then the length of segment ys should be *added* to d, and if s is obtuse then the ys should be *subtracted* from d.

In this case, m is obtuse, so we must add xm to d, and s is acute, so we must also add ys to d. This yields a true distance of $62^\circ 32' 18''$.

Thompson's value for D is $62^\circ 32' 36''$, only an 18" difference. Interestingly enough, we could write our corrections as '+ 2-16 + 2-10' This is clearly what Thompson is writing at the bottom of the page where he notes '+ 2-5 + 2-20 + 9"' Thompson's values differ slightly from our results, but it must be kept in mind that there were several variations of this approximation method. When I clear this distance employing a rigorous mathematical method by Young (Cotter, 214) using the formula :

$$\cos D = \{ \cos d + \cos(m + s) \} \frac{\cos M \cdot \cos S}{\cos m \cdot \cos s} - \cos(M + S)$$

I obtain the value $62^\circ 32' 40''$ which is within 4" of Thompson's value.

Finding GMT

Thompson now has a true distance between the center of the moon at the center of the sun as measured when his watch said 21h 53m 15s (11:53:15

am). He would now turn to his nautical almanac, where he would find true lunar distances for every three hours GAT for various bodies close to the ecliptic. Thompson would then use linear interpolation, assisted by proportional log tables, to compute the GAT time for the distance which he observed. Thompson now knows the time GAT that corresponds to his watch time of 21h 53m 15s. How he uses this time to compute longitude is the subject of the following article.

Art VIII. Recomputing Thompson's Data— Longitude from GT, Local Time, Magnetic Variation. By J. Gottfred.

In addition to the various observations discussed in the previous articles, Thompson also computed longitudes from his knowledge of Greenwich and Local Apparent Times, set his watches to local apparent time by observing the sun or other stars, and computed the magnetic variation at his locale.

To demonstrate how these values were determined, I will use a hypothetical case (since Thompson leaves us no calculations) using the data from November 3, 1810.

On this day he observed two lunar distances, and made four observations of the sun's altitude. From figure 1, and using the law of cosines for spherical triangles, it can be seen that

$$\cos t = \frac{\cos(\cos Ho) - \cos(\cos L) \cdot \cos PD}{\sin(\cos L) \cdot \sin PD}$$

This can be simplified to :

$$\cos t = \frac{\sin Ho - \sin L \cdot \cos PD}{\cos L \cdot \sin PD}$$

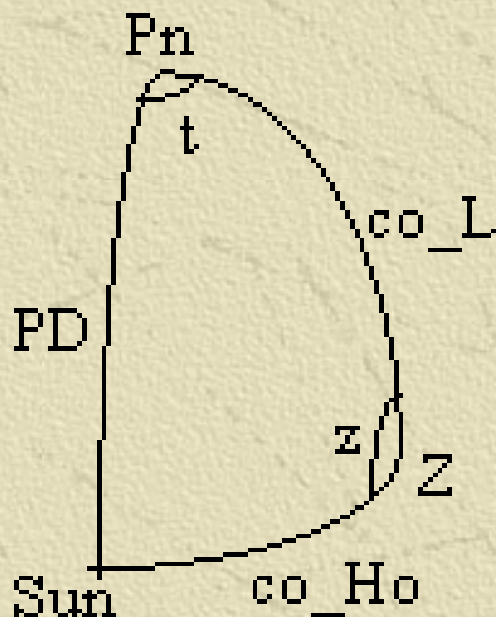

Figure 1 — **Pn**— The north pole. **Z**— The observer's zenith. **Sun**— The geographical position of the sun. **PD**— The polar distance of the sun. **co-L**— Observer's co-latitude ($90^\circ - \text{Latitude}$). **co-Ho**— The co-height of the sun ($90^\circ - \text{Ho}$). **t**— The meridian hour angle. **z**— Azimuth angle.

This observation can be used to compute the observer's local apparent time, even if the observer does not know what time it is in Greenwich. The meridian hour angle t can be converted into hours with the formula:

$$T = t^\circ \times \frac{1 \text{ hr}}{15^\circ}$$

For an afternoon observation of the sun this converts directly into local apparent time p.m. If Thompson has done a lunar distance observation within a hour of this 'time shot' (to reduce the effects of an inaccurate watch), then he now knows the difference between the local apparent time in Greenwich, and the local apparent time at his position. This time difference is simply converted into degrees at 15° per hour to find his longitude west of Greenwich.

Even if Thompson does not have a lunar distance to go along with his time

shot, he will still make such time observations in order to keep his watch set to local apparent time. This allows him to know exactly when noon will occur (subject to watch error and how far he has moved in longitude since he last set his watch). This allows him to plan his day's events so that he does not miss a double meridian altitude observation, the most important daily observation for any navigator to make.

Watch Rate Computed

There is clear evidence that Thompson's watches were next to useless as navigational tools. First, he never computes a watch rate, nor uses one in his calculations. Secondly, he always keeps time-critical observation pairs as close together in time as possible to ensure the maximum accuracy. Thirdly, his notes show that at nearly every opportunity he computed the local apparent time and reset his watch. An excellent example of this is provided in his observational notes for November 26, 1810. In these notes he lists the following values (Thompson's data in italics) :

<i>H ' "</i>	<i>o ' "</i>	Line #
<i>55 .. 9</i>	<i>28 .. 21½</i>	1
<i>55 .. 42</i>	<i>18¼</i>	2
<i>56 .. 13</i>	<i>15¼</i>	3
<i>1[6]7 .. 4</i>	<i>55</i>	4
<i>55 .. 41</i>	<i>28 .. 18 .. 20</i>	5
<i>+18 .. 58</i>	<i>-3</i>	6
<i>1 .. 14 .. 39</i>	<i>28 .. 15 .. 20</i>	7

Lines 1 to 3 are Thompson's observation pairs where he is recording his watch time (i.e. 0 hours (noon), 55 minutes, 9 seconds) and the height of the body as measured by the sextant (i.e. $28^{\circ} 21.5'$). On line 4 he writes down the sum of the values, and in line 5 the average values. This gives him a point on a line which is the best fit through all three values— a standard technique of the day for improving sight accuracy (Garnett, 31).

The following step is not clear from Thompson's notes, for the values on line

six are not filled in at the same time. What Thompson does next is to write down his sextant index error correction under the right-hand column on line six. He then finds the final sextant altitude which he records on line 7. At this point he then computes the local apparent time of the observation as discussed above. He then writes the corresponding local apparent time next to the sextant altitude to which it applies. This is the value in the left hand column on line 7. Thompson then computes the difference between what his watch said and the actual local apparent time at the instant of the observation. In this case, his watch is 18 minutes 58 seconds slow. He notes this value in the space on line 6 in order to conserve paper and to keep things neat. Thompson would no doubt immediately set his watch forwards by 19 minutes so that on the next day, he would know to within a few minutes when local apparent noon is going to occur so that he can get set up to make a meridian altitude observation of the sun—the navigator's most important daily observation. Indeed, in the notes for this day he records that 'Examined watch moved 20' forward'. Normally he does not bother to record the fact that he has reset his watch.

When you first look at these columns of numbers it appears at first glance that the time value on line 6 is some sort of correction which applies to get the time on line 7, but this is not so. This example in his notes is a good one to examine, as it seems that the values in the left-hand column on lines 6 and 7 were written in later, as he is using a pen with a different width. This same pattern can be seen in many other entries where the time correction value is squeezed into too small a space or does not line up correctly with the other numbers in the column.

Using two observations from November 3, I calculate that Thompson's watch was gaining about $3\frac{1}{4}$ seconds per hour on that day. When I look at his watch corrections overall for the period of the case study, correct them for changes in his longitude, and assume that he reset his watch each time he made a time observation, I find that his average watch rate was 4 seconds per hour fast, ± 9 seconds. This is quite poor. In 1806, Garnett remarks that :

'...Dr. Maskelyne observes, that a watch that can be depended upon within a

minutes for 6 hours is absolutely necessary ; but I would recommend to have at least one pocket chronometer or time piece, for connecting the observation for finding the time, with that for the distance. They are made by Mr. Arnold in London as low as 25 guineas ; also by Mr. Earnshaw and Mr. Broeckbank ; and would be extremely useful for a variety of purposes both for the longitude and latitude, and in discovering currents.' (Garnett, 30)

Thompson's watches from Joseph Jolly were worth only 12 guineas each in 1794 (Smyth, 8). These would be better-than-average watches for the time, but apparently not in the 'pocket chronometer' league. It would also appear that his watches were never upgraded, and that 16 years later he still had not acquired a pocket chronometer. Thompson himself noted on August 2, 1811 that :

'All the Obsns made going to the Sea was with a com[mon] Watch that went very badly, losing time— on my return also with a com[mon] Watch that went tolerable well'. (Belyea, 163)

It would seem clear that his watches were only useful for tracking the general time of day, the Greenwich time to the nearest half-hour, and the time separations between double altitude or lunar distance longitude pairs for intervals of less than an hour.

Compass Variation

If the observer records the bearing of the body along with its altitude, then it is possible to compute the magnetic declination (variation). From figure 1, it can be seen that:

$$\cos Z = \frac{\cos(PD) - \cos(co_L) \cdot \cos(co_Ho)}{\sin(co_L) \cdot \sin(co_Ho)}$$

This becomes :

$$\cos Z = \frac{\cos(PD) - \sin L \cdot \sin Ho}{\cos L \cdot \cos Ho}$$

Angle Z is the true bearing of the sun at the time of the observation (called the azimuth), in this case in degrees west of north. In this example this can be converted to a standard compass bearing by subtracting z from 360°. The difference between the calculated bearing and the bearing measured by the compass is the variation.

Art IX. A New Latitude for the Goods Shed Computed from Thompson's Data. By J. Gottfred.

On December 5, 1810, while at the location of his 'goods shed' on the Athabasca, David Thompson observed a series of lunar distances and two time shots to be used for the longitude component of the two lunar distances. On December 6, he observed a meridian altitude of the sun and computed a latitude of N 53° 23' 27" for the location of the goods shed. He then used this latitude to compute the longitudes observed on the previous evening. This latitude is quite different from the latitude of the accepted location of Thompson's goods shed.

In [Article V](#), I examined Thompson's latitude observation from December 6 and showed how it was made with his reflecting artificial horizon, and that Thompson did not make any computational errors in performing the calculation. This suggests that the observation should be a very good one, and it should be close to the truth.

Unfortunately, this single observation says nothing about how accurately he took the measurement. Any number of arguments may be made to suggest that this single value is not to be relied upon— perhaps he was having an 'off day' and was careless with the observation. Perhaps he misread the index vernier. Maybe his parallel glasses were not quite parallel and produced a significant distortion. Perhaps there was a strong temperature inversion

caused by a nearby storm which strongly affected the refraction of the earth's atmosphere. It was partly cloudy on that day, so perhaps the cloud interfered with his ability to accurately see the edge of the sun's limb. All of these arguments can legitimately cast some doubt on the accuracy of any single observation. However, if another latitude for the site can be computed using different celestial objects observed on a different day under different conditions and at different azimuths, then, should the results agree to a reasonable extent, all of the above arguments can be shown to be unfounded.

Thompson's time shots from December 5 allow a new latitude to be computed. This latitude was never computed by Thompson ; either he never realized that it could be done, or he didn't bother. If he did not realize that it could be done, then this suggests that he was well grounded in all of the standard techniques as outlined in the navigational texts, but that he really did not have a firm grasp of how he actually arrived at his answers— he just followed the instructions for 'standard sights'. I favor this interpretation because he computed all the other permutations of his sights on this journey, and since he did not have a latitude to use that evening he was forced to wait until noon the next day before he could do the calculations.

Thompson's observations of the stars Vega ('Lyræ') and Capella allow me to compute a latitude using the double altitude method as described in [article VI](#). Table XXX of Garnett's *Tables Requisite...* from 1806 lists the right ascensions and declinations of the principle navigational stars, as well as how much these values change per year. This information is summarized as follows :

Star	RA	Var./yr	Dec.	Var./yr
Vega	18h30m20s	2.03s	38° 36' 27" N	+2.6"
Capella	5h 2m 18s	4.41s	45° 47' 16" N	+5.0"

From this information, the right ascensions and declinations of these two stars can be estimated for the time of Thompson's observations in 1810 :

Star	RA	Dec.
-------------	-----------	-------------

Vega	18h 30m 28s	38° 36' 37" N
Capella	5h 2m 36s	45° 47' 36" N

We also have Thompson's observations and watch times which I provide as they appear in his journal (corrected for index error).

Star	WT	Hs x2 corr.
Vega	7h 14m 53s	77° 18' 30"
Capella	7h 56m 39s	88° 24' 56"

From the values of right ascension (RA) we can compute the difference in RA between the two stars in 1810. Note that Capella was visible in the east, and Vega was visible in the west, therefore the time separation is 24h - 18h 30m 28s + 5h 2m 36s = 10h 32m 8s. Multiplying by 15° per hour results in an angle between the two stars of 158° 2' 0".

Thompson observed Vega first, which you can visualize as 'pinning' its location to the heavens at the instant of the observation. He observed Capella 41m 46s later. During that time, as the heavens appear to rotate overhead, Capella moves closer to the 'pinned' position of Vega. Again, converting time to arc and subtracting this from the angle separating the two stars we get the meridian hour angle (t) which is 147° 35' 30".

Thompson noted that the air temperature was -2°F, and from a topographic map of his approximate position I feel that his elevation was just under 1100 meters. Assuming average atmospheric conditions this results in a refraction factor f of 0.98. True refraction = mean refraction * f . The altitudes of these two stars above the horizon can therefore be computed using modern refraction tables in the following manner :

	Vega	Capella
Hs x 2 corr.	77° 18' 30"	88° 24' 56"
Divide by 2	38° 39' 15"	44° 12' 28"
R	<u>-1' 10"</u>	<u>- 59"</u>

Height	$H_v = 38^\circ 38'$	$H_c = 44^\circ 11'$
observed	5"	29"

From figure 1, and using the data above as well as the formulae presented in the article on computing latitude from double altitudes, the following values can be computed :
 $d = 90.72550^\circ$, $A_1 = 21.94522^\circ$, $A_2 = 25.50479^\circ$. Note that in this case Z is south of the great circle connecting Vega and Capella, so $A_3 = A_1 + A_2$. The final latitude computed is $N 53^\circ 21' 27''$

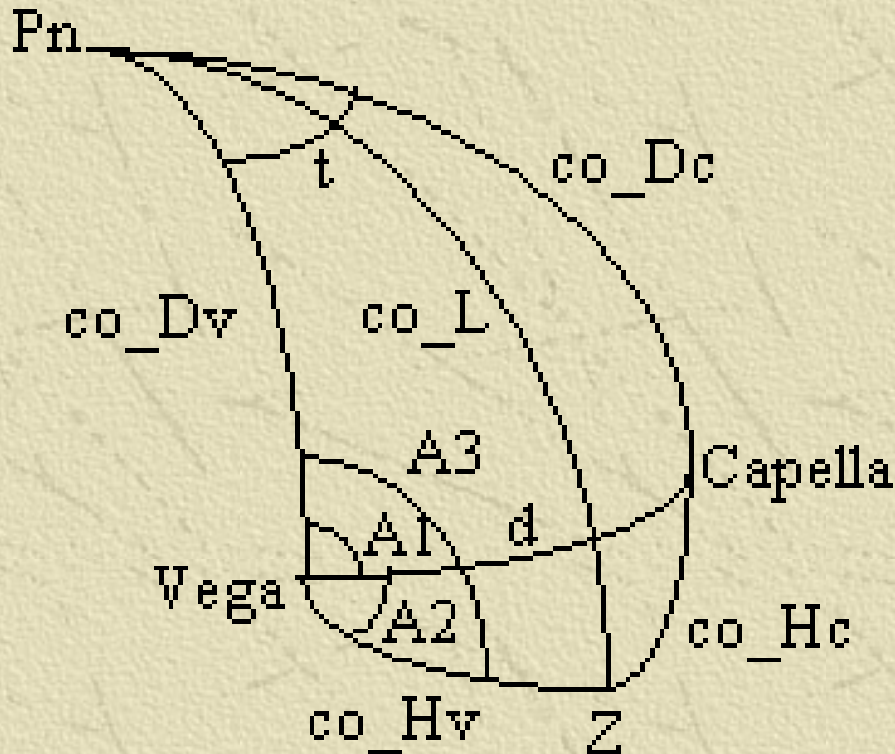

Figure 1 — **Pn**— The north pole. **Z**— Thompson's Zenith. **co-Dv**— 90° -declination of Vega. **co-Dc**— 90° - declination of Capella. **d**— distance between Vega and Capella along a great circle on the celestial sphere. **t**— The meridian hour angle between Vega and Capella. **co-Hv**— 90° - observed altitude of Vega. **co-Hc**— 90° - the observed height of Capella. **co-L**— 90° - the latitude of the observer.

This latitude is 2' (2 nm) south of the latitude that Thompson computes on December 6. This observation is probably not quite as accurate as the double meridian altitude observation of December 6, but if we assume for the sake of argument that they are equally valid, then the position of the 'goods shed'

must lie at latitude $N53^{\circ} 22' 27'' \pm 1'$. The close correlation between the latitudes observed on December 5 and 6 effectively removes the possibility of significant systematic or random error in the execution of the observations. As the south end of Brûlé Lake is roughly 7.8' south of this position, this rules it out as a possible location for Thompson's goods shed.

Postscript

For those readers familiar with celestial navigation who are eager to try Thompson's methods, you may write the author care of *Northwest Journal* for additional information, assistance, etc., as well as to obtain copies of the author's *Tables Useful for Celestial Navigation*. This booklet contains : mean refraction tables circa 1781; refraction factor (f) tables circa 1781; modern mean refraction tables; modern refraction factor tables; conversion between mb, inches Hg and mm Hg; barometer corrections for altitude above sea level; a table of barometric pressure by boiling point of water (insert) which when used with the barometer correction table yields the observer's altitude; conversion of arc to time; temperature conversion; and miscellaneous data and formulae. A full explanation of each table is included along with information on how they were computed and the data source used.

Modern plastic practice sextants are available which are accurate enough for computing latitudes. (The Davis Mk 15, \$107 US, looks like a good bet.) The *Nautical Almanac* sells for \$16.95 US. All the stuff you require (except for the land navigation tables) can be ordered through Celestaire at 1-800-727-9785.

Art X. Glossary and References. By J. Gottfred.

Apparent altitude (H_a) - The height of the body above the horizon as it appears to the observer once mechanical measuring errors have been eliminated. See also *Observed Altitude* (H_o), and *Sextant Altitude* (H_s).

Azimuth angle (Z) - The angle between the sides *co-latitude* and *co-calculated altitude* of the spherical triangle connecting the north pole, the observer's zenith, and the geographical position of the observed body.

Azimuth (Zn) - The angle between true north and the body, measured clockwise from true north. Azimuth is always positive, and between 0° and 360° . Zn is computed from *azimuth angle* (Z).

Cleared lunar distance (D) - The angular distance between the moon's center and another body as measured from the center of the earth. Obtained from the *lunar distance* (*d*).

Co-declination (co-d) - One side of a spherical triangle equal to 90° minus the declination of the body.

Co-latitude (co-L) - One side of spherical triangle equal to 90° minus the latitude of the observer.

Declination (dec) - The position of a celestial body on the celestial sphere measured in degrees north or south of the celestial equator. It is exactly equivalent to latitude and is measured the same way. For example, if at some instant the declination of a body is S $15^\circ 32' 4''$, then at that instant the geographical position of the body is at latitude S $15^\circ 32' 4''$. **Magnetic declination** is the difference between magnetic north (the direction the compass needle points) and true north (roughly Polaris). Also called variation or compass variation.

f - Correction factor applied to *mean refraction* to correct for non-standard atmospheric pressure and temperature.

Geographical position (GP) - The intersection of a line connecting the center of the Earth to the center of a celestial body and the surface of the Earth. For any instant of time this spot is the position on the Earth's surface at which the body is at the zenith. The GP may be expressed in terms of declination and right ascension/hour angle.

Great circle - The shortest distance between two points on the surface of a sphere. A great circle is described by the intersection of a plane cutting through the center of a sphere and the surface of the sphere.

Greenwich Apparent Time (GAT) - This is the local apparent time at the Greenwich meridian, which is defined as being at zero degrees of longitude. GAT differs from Greenwich Mean Time (GMT) by the difference of the equation of time for that day. Thompson did not use GMT.

Ha - See *apparent altitude*

Horizontal parallax (HP) - The parallax of the moon when it is observed at the horizon.

Ho - See *observed altitude*.

Hs - See *sextant altitude*.

Index correction (IC) - The correction to applied to sextant altitude (Hs) to correct for registration error of the instrument. IC is opposite in sign to *index error* (IE).

Index error (IE) - The registration error of the sextant caused by the horizon and index mirrors being non-parallel. IE is positive if the error is on the arc, and negative if the error is off the arc. See also *index correction* (IC).

Latitude (L) - Imaginary parallel lines on the earth's surface at right angles to the earth's axis of rotation. The equator is 0° latitude, the north pole is 90° north latitude, and the south pole is 90° south latitude. See also *declination*.

Longitude (Lo) - Imaginary lines on the earth's surface which are described by *great circles* passing through the north and south poles. The prime *meridian* is 0° longitude and is located in Greenwich, England. Longitude is measured east and west of Greenwich to 180°.

Lunar distance (d) - The angular distance between the moon's limb and another celestial body, usually on or near the ecliptic as measured with a sextant. Also, a longitude calculated using this measurement. See also *cleared distance* (D).

Mean refraction (R_0) - The refraction of the atmosphere at a standard temperature of +7° C and a pressure of 1010 mb.

Meridian - The meridian is the line of *longitude* which passes through the *zenith*. When the sun is on the observer's meridian, it is local apparent noon.

Meridian angle (t) - The smallest angular distance between the meridian at the observer's position (Z) and the meridian of the geographical position (GP) of a celestial body. Also the smallest angle between the meridian of any two positions or bodies. Meridian angle is measured east or west and is always positive.

Nautical mile (nm) 1nm = 1' of latitude = 1852 meters.

Observed altitude (H_o) - The altitude of the body above the horizon as measured by the observer, once all corrections have been applied to the observation.

Parallax in altitude (PA) - The component of the moon's horizontal parallax which applies for altitudes greater than 0° . PA is computed as :

$$PA = HP \times \cos (H_a)$$

Refraction correction (R) - A correction to the apparent altitude of a body which accounts for the bending of light from the body as it travels through the Earth's atmosphere. The refraction correction is computed as:

$$R = R_0 \times f$$

Semi-diameter correction (SD) - A correction to the apparent altitude of a body which adjusts for observations on the limb of a body. For stars and planets, no SD correction is required. For the sun and moon, SD corrections are listed for each day in the nautical almanac. For the moon, SD can also be computed as:

$$SD = 0.2724^{\circ} \cdot HP$$

The value of SD is positive for a lower limb observation, and negative for an upper limb observation.

Sextant - A hand-held instrument for measuring the angle between two distant observed objects.

Sextant altitude (Hs) - The height (altitude) of a body as measured by the sextant and prior to applying any instrument or artificial horizon corrections. See also *apparent altitude*.

Spherical triangle - A triangle drawn on the surface of a sphere consisting of sides which are segments of *great circles*. The length of any side of a spherical triangle is the angle of arc described by that side as measured from the center of the earth. The angle between two sides of a spherical triangle is the angle as measured on the surface of the sphere.

Z - See azimuth angle.

Zenith - The point on the celestial sphere which is directly overhead.

References & Bibliography

Alberta Forestry, Lands & Wildlife. *Edson 83F*. [Topographic Map.] Provincial Mapping Section, Land Information Services Division. 1988.

Bowditch, Nathaniel, LL.D., *The American Practical Navigator : An Epitome of Navigation*, Volumes I, II. Defense Mapping Agency Hydrographic/Topographic Center Pub. No. 9, 1984.

Cotter, Charles H. *A History of Nautical Astronomy* American Elsevier Publishing Company : New York, 1968.

Garnett, John. *Tables Requisite to be Used with the Nautical Almanac for the Finding of Latitude and Longitude at Sea*. John Garnett : New Brunswick, New

Jersey, 1806.

Gottfred, J. 'Period Navigation', in *Northwest Journal*, Vol. III, April to July 1995. pp. 11-18.

Gottfred, J. *Tables Useful for Celestial Navigation over Land*, 2d ed. J. Gottfred : Calgary, 1995.

Gottfred, A. & J. 'The Life of David Thompson', in *Northwest Journal*, Vol. V, November 1995 to January 1996, pp. 1-19.

Her Majesty's Nautical Almanac Office. *The Star Almanac for Land Surveyors*. London, HMSO.

Henry, Alexander (the Younger). *New Light on the Early History of the Northwest : The Manuscript Journals of Alexander Henry...* Elliot Coues (ed.) Reprint-Ross & Haines : Minneapolis, 1965. Originally published 1897.

Marriott, C. A. *Skymap V2.2.4*. Planetarium Software for Windows. 1992, 1994.

Sebert, L. M. 'David Thompson's Determination of Longitude in Western Canada', in *Canadian Surveyor*. Vol. 35, March 1981, no. 4 : 405-414

Smith, Allan H. 'An Ethnohistorical Analysis of David Thompson's 1809-1811 journeys in the Lower Pend Oreille Valley, Northwestern Washington', in *Ethnohistory*, Vol. 8, No. 4, Fall 1961.

Smyth, David. 'David Thompson's Surveying Instruments and Methods in the Northwest 1790-1812.' *Cartographica* 18, no. 4 (1981), pp. 1-17.

Stewart, W. M. 'David Thompson's Surveys in the North-West', in *Canadian Historical Review*, 1936.

Thompson, David. *Columbia Journals*. Barbara Belyea (ed.) McGill-Queen's : Montreal, 1994.

Thompson, David. Original manuscript journals, Archives of Ontario volume 25. Unpublished. Archives of Ontario.

United States Naval Observatory (USNO). *Nautical Almanac 1996*. Paradise Cay Publications : Middletown, California, 1996.

Copyright 1994-2002 *Northwest Journal* ISSN 1206-4203. [May I copy this article for my class?](#)

[Article Index](#)

nomad electronics



[Home](#) • [Pocket Stars PDA](#) • [Pocket Stars PC](#) • [Try / Buy](#) • [Support](#) • [FAQ](#) • [Forum](#)

Pocket Stars PDA

Pocket Stars PDA is a high accuracy star chart, ephemeris, and Celestial Navigation calculator for the Pocket PC. The ultimate portable astronomy tool.



Free Upgrades
for registered users.

Money Back Guarantee
If you're not delighted with Pocket Stars, we offer a no-quibble refund within 30 days of purchase.

New! Version 3.0 supports all WM2003SE resolutions with Time Animation and Orbital Paths!

Click [here](#) to watch a demo movie.

[Features](#)

[Screen Shots](#)

[Try / Buy](#)



Microsoft® Windows®
for Pocket PC
Logo Certified



Pocket Stars SP

New!

Pocket Stars SP runs on Windows Mobile Smartphones.



A star chart near as your pocket!

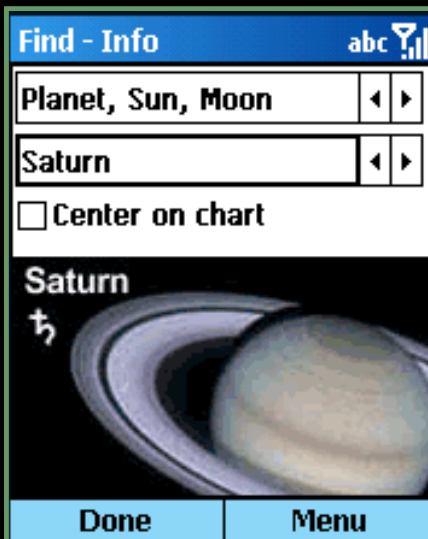

[Features](#)
[Screen Shots](#)
[Try / Buy](#)



Pocket Stars SP maintains full positional accuracy and most of the features of the PocketPC and PC versions.



Pocket Stars PC

Pocket Stars is also available for desktop, tablet, and notebook PCs running Win98, WinME, Win2K, WinXP, and greater.

Buy both PC and PDA versions and **Save!**

[Click here for Details](#)



[Features](#)
[Screen Shots](#)
[Try / Buy](#)



The PC and PDA versions of Pocket Stars work together, sharing configuration files containing

observations and settings.

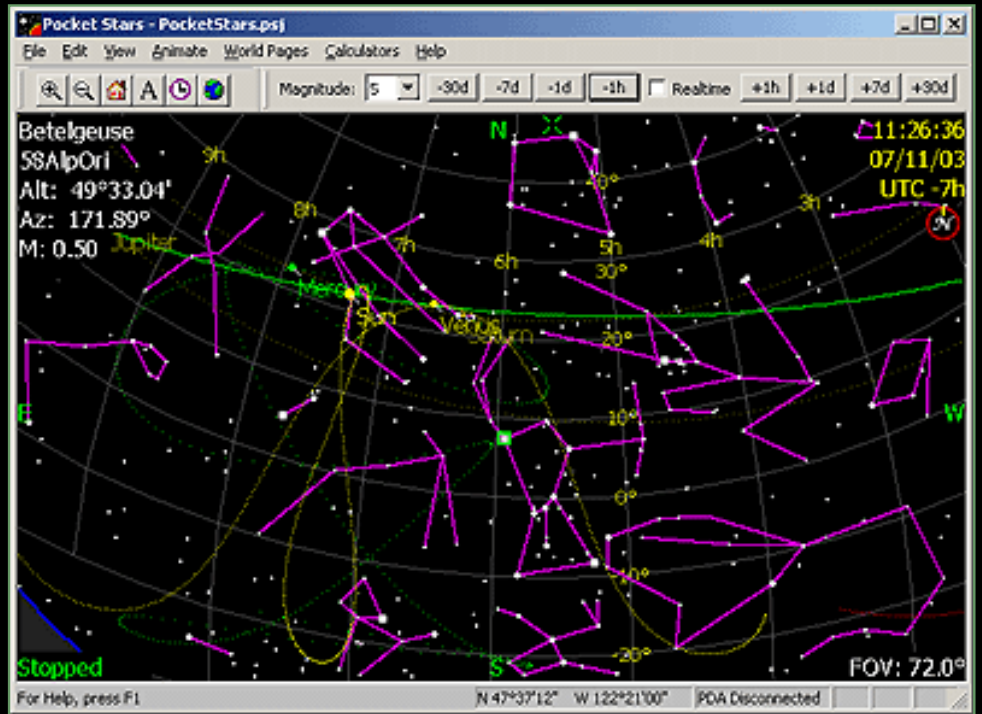

Video Capture

While working at Microsoft, I designed much of the video capture infrastructure in Windows 3.1 / 95 / 98 / 2000.

The links to the right answer some general questions on video capture in Windows, and provide additional tools used for WDM capture driver and DirectShow development.

As time permits, I'll try to answer questions and offer pointers to random developers in need.



Windows Video Capture

[General Info](#)

WDM Video Capture

[Background](#)

VFW Video Capture

[Background](#)

[Drivers and Apps](#)

[Powerpoint presentation](#)

DirectShow

[Background](#)

[VBI Scope](#)

[Stream Scope](#)

[Show Clock](#)

Custom Programming and Consulting

I'm always willing to entertain custom programming projects. My current interests focus upon:

- PocketPC
- Wireless
- Video streaming



Custom Programming

[Resume \(html\)](#)

[Resume \(.doc\)](#)

Sailing

Serenade is our 40' Crealock Pacific Seacraft sailboat.

"Sailboats are like RVs without the stigma."



Trips

[Alaska 2001](#)

Pilot Charts

[North Pacific](#)

Serenade

[Specifications](#)

[Pictures, Interior](#)

[Pictures, Exterior](#)

Jay Alan Borseth
 2419 E Helen Street
 Seattle, Washington USA 98112
 206.200.0625 business
 206.329.6327 home
jaybo@nomadelectronics.com

[Map](#)

 (nearby Meatspace URLs)

Fc **124260**

FastCounter by bCentral

[Home](#) • [Pocket Stars PDA](#) • [Pocket Stars PC](#) • [Try / Buy](#) • [Support](#) • [FAQ](#) • [Forum](#)
[Contact Us](#)

09/01/2004 [NomadElectronics.com](http://www.nomadelectronics.com)

[Home](#)

[Introduction](#)

[Bowditch](#)

[The House](#)

[The Programs](#)



The Bowditch Initiative

a project of Historic Salem, Inc.

P.O. Box 865, Salem, MA 01970

(978) 745-0799

[Contact Us!](#)



Nathaniel Bowditch

1773 - 1838

Navigator, Astronomer, Mathematician

"His fame is of the most durable kind, resting on the union of the highest genius with the most practical talents, and the application of both to the good of his fellow man."

The Boston Athenaeum 1838



A yearlong series of public programs and events in 2002 commemorated the 200th anniversary of the publication of Bowditch's signature work, *The New American Practical Navigator*. Highlights included July visits to Salem by **U.S. Navy and U.S. Coast Guard vessels**, and the August visit by the **U.S. Coast Guard, Bark Eagle**.

[Home](#)

[Introduction](#)

[Bowditch](#)

[The House](#)

[The Programs](#)

[Site Index](#)

September 6, 2004

© [Historic Salem, Inc.](#)

[NOVA Online](#) > [Lost at Sea: The Search for Longitude](#) > Find Your Longitude

[Great Challenge](#) | [GPS](#) | [Find Your Longitude](#)
[Ancient Navigators](#) | [Resources](#) | [Teacher's Guide](#)
[Transcript](#) | [Site Map](#) | [Longitude Home](#)

[Editor's Picks](#) | [Previous Sites](#) | [Join Us/E-mail](#) | [TV/Web Schedule](#) | [About NOVA](#)
[Watch NOVAs online](#) | [Teachers](#) | [Site Map](#) | [Shop](#) | [Search](#) | [To print](#)
[PBS Online](#) | [NOVA Online](#) | [WGBH](#)

© | Updated October 2001



NOVA Teachers

SEARCH NOVA TEACHERS

[Back to Teachers Home](#)

Lost at Sea: The Search for Longitude

Teacher's Ideas

Navigating Around the World by Observing the Sun

James I. Sammons, Jamestown School Rhode Island

[\(back to Teacher's Intro\)](#)

As you saw in the NOVA episode, [Lost at Sea: the Search for Longitude](#), finding your position on the world oceans is very important. We take our location for granted today because we have modern electronics and radio. But what was it like when those inventions were not available? If you've looked out from the beach on a clear day, you know that it seems that you can see forever. Actually, depending on how high your eye is above the water, the horizon is only a few miles away. Even the highest mainmast lookout would lose sight of land at 25 to 35 miles on a good day! And that distance could be covered in hours.

Back when ships were made of wood and powered by wind, one of the most valuable members of the ship's company was the navigator. This was often the Captain, or the First Officer. That tradition continues today; that's why Star Trek's Captain Picard called his First Officer, Commander Riker, "Number One". To give you a feel for navigation at sea when it really counted, we're going to find the Latitude and longitude for your school as though it were a ship at sea back in the old days. Welcome aboard, First Office!

Latitude

To begin, we have to introduce the concept of Horizon and Celestial Sphere. Whoa, don't

panic. These are new terms, but the ideas are simple. We all know that the Earth is round, but when you look off in the distance, the horizon seems flat. That's because we're so tiny compared to the Earth, that we just can't see the curve. But compared to space, the Earth is also very tiny. We can make our navigation problem simpler if we *assume* the Earth *is flat* right where we're standing and draw a straight line to represent our horizon. Figure 1 Shows this idea. Remember, the observer figure is actually so close to the surface of the circle that he can't see around its sides.

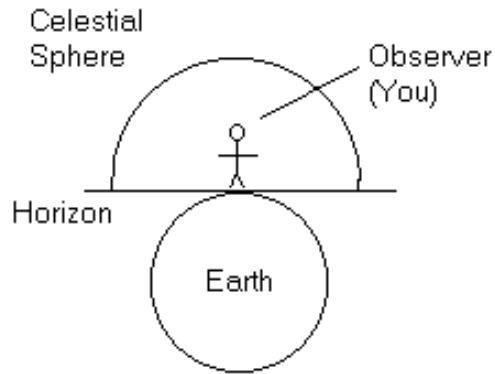

Figure 1.

Now let's combine the Horizon and Celestial Sphere idea with measuring the angle between the Horizon and something in space. Figure 2 shows three observers; A, B, and C, at different Latitudes on the surface of the Earth. The Sun is very far away, but directly over the Equator. That is, an imaginary string stretched between the centers of the Earth and Sun would pass through the Earth's Equator.

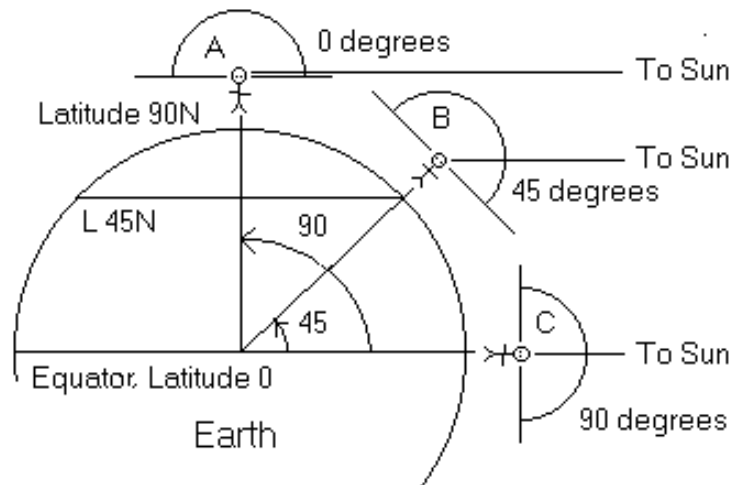

Figure 2.

Remember that each observer is really a tiny point on the surface of the Earth. Above each point, the observers are shown in an enlarged Celestial Sphere so that we can see the detail. Check out observer B at Latitude 45 degrees North. That's written "L 45°N". If observer B measures the angle from the Horizon to the Sun at noon, the result will be 45 degrees as long as the Sun is over the Equator. This measurement is called the Altitude of the Sun.

If you're on your toes, you've probably figured out the whole Latitude thing for noon when the Sun is over the Equator. However, before you put to sea in an inner tube, check out the Altitude of the Sun (Angle between the Horizon and the Sun) for observers A and C. It's not so simple as reading the angle and that's your Latitude. Observer A at the North Pole is at Latitude 90°N, but observes a noon Altitude of the Sun of 0°. The Sun appears to him to be right on the horizon, just like at sunset. At the same time, Observer C at the Equator is at 0°, but observes a noon Altitude of the Sun of 90°, directly overhead. Can you figure the simple trick to convert the Altitude correctly?

Notice that as you move away from observer C on the Equator, towards observer A at the North Pole, the Latitude increases and the Altitude of the Sun decreases. This relationship is familiar to math types as complimentary angles and can be summarized as:

$$L = 90^\circ - \text{Sun's Altitude}$$

Let's assume that you observe the Altitude of the Sun to be 80° at noon and that the Sun is directly over the Equator. What is your Latitude?

$$L = 90^\circ - \text{Sun's Altitude}$$

$$L = 90^\circ - 80^\circ$$

$$\text{Latitude} = 10^\circ\text{N}$$

Better get out your SPF 40 sunscreen, `cause it's going to get hot that close to the Equator!

This simple relationship works great when the noon Sun is directly over the Equator. How often is this true? Not very, I'm afraid. Fact is, only on two days of the year, March 21st and September 21st. Not to panic, I told you this was simple and it is. After all, if those old timers could do it with a compass and a stick in the eye, called a cross staff, you can do it too.

In the practice example we subtracted the Altitude of the Sun from 90 degrees. Why?

Because Latitude doesn't go higher than 90 degrees. If you had a Latitude greater than 90

degrees, you'd go over the Pole and start back toward the Equator. But what if the Sun were not on the Equator and was actually 5 degrees north of it? What would the observed Altitude of the Sun be then? Study figure 3 and see if you can figure out how you could correct the observed Altitude of the Sun for any Sun position.

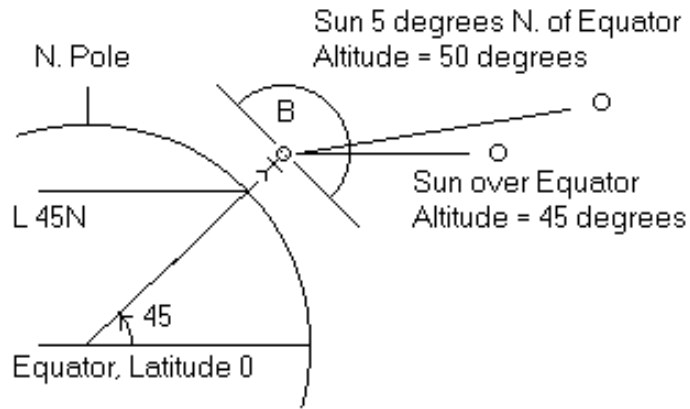

Figure 3.

Our original formula works fine when the Sun is over the Equator. To make it work for any Sun position and therefore any date, we need to make a correction. We need to adjust the result for when the Sun is north (above), or south (below), of the Equator.

In figure 3, the Sun is shown 5 degrees north of the Equator. The observed Altitude of the Sun is 50 degrees and we know from the sketch that the correct Latitude is 45°N. But look what happens when we calculate Latitude:

$$\begin{aligned} L &= 90^\circ - \text{Sun's Altitude} \\ L &= 90^\circ - 50^\circ \\ \text{Latitude} &= 40^\circ\text{N} \end{aligned}$$

Hmmm, the result should have been L 45°N. We can fix this if we *add* the number of degrees when the Sun is *north* of the Equator and *subtract* the number of degrees when the Sun is *south* of the Equator. This concept is called the Declination of the Sun and has to be included in our Latitude formula so that it will work at any date. Here's our final formula:

$$L = 90^\circ - \text{Sun's Altitude} + \text{Declination of the Sun}^*$$

*Northerly Declination is added.
Southerly Declination is subtracted.

You may wonder how this new improved formula can work just like the first version when the Sun is over the Equator. That's easy, if the Sun is over the Equator, its Declination is zero. It's just like the new term at the end of the formula went away.

Try these examples to show your stuff. We'll assume that the observations were made at noon with the Sun to the south using your best cross staff and that the Declination of the Sun came from the Court Astronomer.

Problem	Declination	Altitude	Latitude
1	15° North	48°	
2	17° South	73°	
3	23° North	22°	

$$1 = L \ 63^{\circ}N \quad 2 = L \ 56^{\circ}N \quad 3 = L \ 45^{\circ}N$$

How did you do? Here's a little extra thought for you. Suppose you have the same information as in problem 1, but you had to face toward the *north* to measure the Altitude of the Sun. Your Latitude would be L 33°S. If you must face north to view the noon Sun, you're probably in the Southern Hemisphere. The same formula works for ships in the Southern Hemisphere, the correction for the Declination of the Sun is simply reversed. So in this case, 15° North Declination is *subtracted* from the observed Altitude of 48°.

OK, so now you're ready to find the Latitude of your school. If only you had a Court Astronomer to provide the Declination of the Sun. Hey - you can do that too! Figure 4 shows the Earth at four positions in its orbit around the Sun. The sizes are exaggerated to make it easier for you to see what's going on. The Earths are shown tipped 23.5 degrees relative to a vertical line straight through the Sun. Why the Earth is tipped like that is another story having to do with how planets are formed. Right now we have to figure a way of determining the Declination for any day.

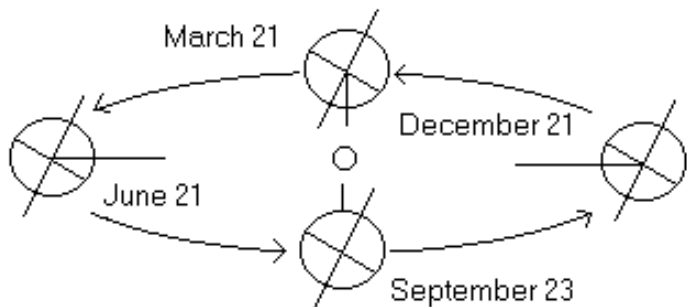

Figure 4.

Note the Equator on the Earth at the June 21st. position. You can see that the direction to the Sun from that Earth shows the sun to be 23.5 degrees north (above) of the equator. A similar observation of the December 21st. Earth shows that the Sun direction is now 23.5 degrees south (below) of the equator. The remaining Earths at March 21st. and September 23rd. show the Sun to appear directly above the Equator. For Earth positions between the four shown, intermediate values are observed.

This concept was well known to ancient civilizations and was the main principle behind "primitive" solar observatories such as Stonehenge and Native American Medicine Wheels. You probably recognize it because it's studied in most middle level science classes as the cause of our seasons.

Chances are, your local Stonehenge is nonexistent. In lifeboat navigation, they teach you how to make a table of the Declination of the Sun by tracing something round like a life ring onto a piece of graph paper. But you can find the Declination of the Sun right in your classroom. Printed on most globes, usually off the Ecuadorian Coast but always on the Equator, is the Analemma. This figure eight is a table of the Declination of the Sun and the Equation of Time. Ignore the time bit for now and simply find the month you're looking for and pick off the number of degrees above or below the Equator where that month is printed. If the Sun is above the Equator, it's called *North Declination*, if below the Equator, *South Declination*. Now I'll bet you're the only kid in Kansas that knows what the Analemma is used for!

Although this explanation is wordy, it's a fairly simple concept. You'd be surprised at how accurately Latitude can be determined with very crude stuff. You've probably noticed that I have referred to Altitudes taken only at noon. The reason is that Latitude from the observed height of the Sun is simple, but only at Local Apparent Noon. Local Apparent Noon, or LAN, simply means noon at your exact location. Finding Latitude at *other* times involves some *veeery heavy* math (solid trigonometry) as referred to in the NOVA program.

This places a premium on knowing when Local Apparent Noon occurs as your ship surges along. How do you know? Remember, this skill was well developed long before Harrison's chronometer. This is one of those swell things that turns out to be easier than it looks. Local Apparent Noon corresponds to two events: when the Sun is exactly south of your ship and when the Sun is at it's highest point in the sky. Your ship's compass will tell you when the Sun is exactly south, and if you measure the Sun's height for a period of time beginning as the Sun is still climbing and ending when it's clearly sinking, you'll have the greatest height among your readings.

Congratulations, you are now a fully qualified First Officer, a Sun Navigator of the Days of Exploration.

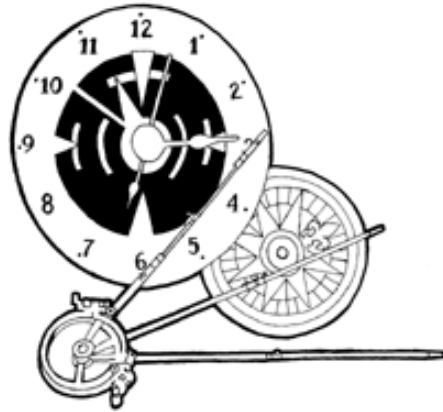

Longitude

And this is where the skill of marine navigation stood for a very long time. Ships could know their north-south line of Latitude, but they had no way of knowing how far east or west they were along that line. It's like two people trying to drive a car, but only one can see. One knows when to turn the wheel right, but the other can't see so doesn't know when to turn the wheel left. Smack up a lot of cars that way, and they smacked up a lot of ships for the same reason.

This is the whole point of the NOVA episode [Lost at Sea: the Search for Longitude](#). If only you could know your longitude. Taken together with Latitude which is easy, these measurements allow plotting of the vessel's *position* on the surface of the Earth. With an accurate sense of time, you can find your east-west line of longitude. This is why Harrison sought the 20,000 pound prize by building an accurate clock.

Time and Rotation of the Earth

Just as we saw in finding Latitude, finding longitude is easy enough when we've learned three basic ideas. The first of these ideas is the relationship between time and the rotation of the Earth. It takes an *average time* of 24 hours for the Earth to rotate 360 degrees so that a spot on its surface will move from under the Sun and then just return to it's under-the-Sun starting position. In 12 hours, the Earth will turn half around. In 6 hours, a quarter. If you divide the number degrees in a circle by the number of hours in a day, we find that the Earth turns 15 degrees each hour.

$$360^{\circ} \div 24 \text{ hours} = 15^{\circ} \text{ per hour}$$

We can take this a step further and state that the Earth turns one degree in four minutes.

$$1 \text{ hour} = 60 \text{ minutes} \div 15^{\circ} = 4 \text{ minutes per degree}$$

The second idea is simple enough, but very confusing. Take some time here and be sure you understand it well. We have to distinguish between *events* and *time*. The events and time idea is what gives adults a headache when they try to figure out what to do to their clocks when Daylight Savings Time changes. That's why we have the no-brainer saying: "Spring forward, fall back."

To see how events and time fit together, imagine that you're standing beside an amusement ride that turns around and around. As you watch, two friends in separate cars pass you by. First one, then the other. Now imagine that the ride is stopped, you give each friend a stop watch, and tell them to start the watch *just as they circle by you*. You signal the operator, the ride makes one complete turn, stops, and you collect the stop watches.

Clearly the first rider went by you *earlier* than the second rider. For him, the *event* of passing you occurred *earlier*. For the second rider, the *event*, passing you, was *later*. But when you examine the stop watches, the *time* on the first rider's watch is *later* than the time on the second rider's watch. Why? Because the first rider's watch was started *before* the second's. Now imagine that you are really the Sun, the ride is really the surface of the Earth, and your two friends are really two different places on the Earth.

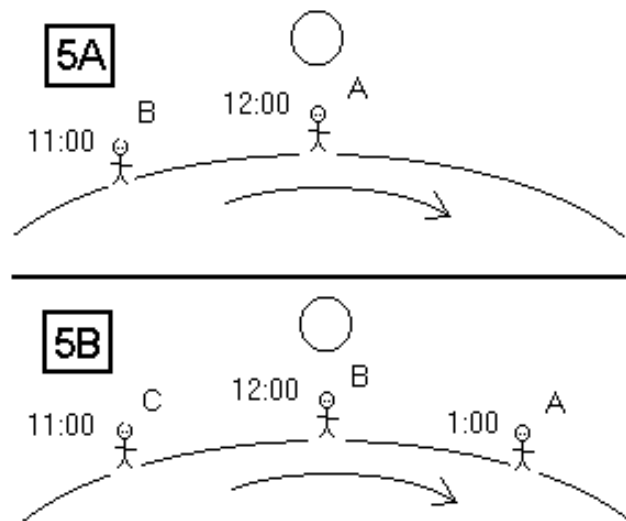

Figure 5.

Observer A in figure 5A observes Local Apparent Noon, which is simply noon for your exact location, and sets his watch to 12:00 based on Sun time. In figure 5B, we see that observer A has been moved eastward by the rotation of the Earth to be replaced by observer B. Observer B now observes Local Apparent Noon and sets his watch to 12:00 based on Sun time. Which observer *experienced* the *event*, Local Apparent Noon, first? Which observer's watch shows the earliest time? Observer C in figure 5B will experience Local Apparent Noon latest of all and yet observer C has the earliest time!

And so it is that we have to be careful about the difference between the *events* and *time*. *Events* like sunrise in the east always happen before the same event in the west. But *time* as shown on eastern clocks is *later* than on western clocks at the same instant. We can summarize this concept with our own no-brainer:

Local time earlier, position is westward.
 Local time later, position is eastward.

To use our no-brainer, we have to be comparing our position to some *other position*. So if you knew, for example, that *your* time was 1 hour later than your pen pal's time, you would know that you were *east* of your friend. Your time earlier, you're west; your time later, you're east. It's that simple!

If we combine the first and second ideas, we can find any longitude. Every point around the Earth has its own unique Sun time. If you live one degree west (later events, earlier time) of me, your Sun time would be four minutes earlier than mine. Let's see how that works. The

first idea, "Time and Rotation of the Earth" tells us that our time difference will be four minutes.

$$1 \text{ hour} = 60 \text{ minutes} \div 15^\circ = 4 \text{ minutes per degree}$$

The second idea, "Events and Time", tells us direction. Note that the example states that *you* are to the west and *your* time is earlier than mine. Turn that around before you use the no-brainer: *I'm* to the *east*, *my* time is *later*.

In the example above, we compared our position to some *other* position. As you learned in [Lost at Sea: The Search for Longitude](#), Harrison was English and the astronomical data that he used to set his chronometer came from the Royal Observatory at Greenwich, England. So it's perfectly reasonable that the *other* position used by British ships should be Greenwich, England. To this day, all longitude is figured from the line of longitude that runs through Greenwich, England. This is the line of zero longitude and is called the Prime Meridian. Lines of longitude are measured in degrees east and west from the Prime Meridian.

If you think about this for a minute, you'll realize that if you sail westward from the Prime Meridian, your west longitude will increase until you reach the 180° line of longitude where east and west longitude meet on the opposite side of the Earth. As you cross this line, called the International Date Line, your longitude, now east longitude, will decrease until you return to the Prime Meridian or zero degrees longitude.

After Harrison developed his chronometer, British ships would find their position by observing the time and the height of the Sun at Local Apparent Noon. The height of the Sun would produce the ship's Latitude. The time of Local Apparent Noon, recorded as 12:00 *local time*, was compared to the time back in Greenwich as shown on Harrison's chronometer and the difference would produce the ship's longitude.

Well, almost. Back at the beginning of the Longitude section, I said that it takes an *average time* of 24 hours for the Earth to rotate 360 degrees. The third and last idea needed for longitude is the Equation of Time.

Whenever I've mentioned clock time, I've called it average time. That's because the time that everyone keeps for their daily affairs is an average value. But if you measure the length of the day by timing the exact amount of time that is required to go from LAN (Local Apparent Noon) on one day, to LAN on the next day, you discover a curious thing: the length of the day changes slowly. Starting with the clock day equal to the actual Sun day, the Sun day gets slightly longer, then slightly shorter until the clock day and the Sun day are of equal length again. The process continues, but this time the Sun day get shorter first, then longer. Don't confuse this changing *day* length with the seasonal change in *daylight*. I'm referring to changes in the *whole* day, light and dark together. Clock time and Sun time are equal in

length only four times during the year, on the other days they are different by as much as 16.5 minutes.

It's not that the Earth rotates at different speeds; that stays the same. It has to do with the speed that the Earth revolves around the Sun which changes according to something called Keplerian Motion. The important thing is that if you're going to compare Sun time to Harrison's chronometer, you have to change the chronometer's clock time to Sun time so that you're comparing like terms. And that's what the Equation of Time does.

By applying the Equation of Time to the chronometer's clock time, we convert Greenwich Mean Time (Clock time.) to Greenwich Apparent Time (Sun time.) Greenwich Apparent Time, or GAT, is simply the Sun time back at Greenwich, England. Now we can observe Local Apparent Noon and do our simple subtraction of GAT to find our longitude.

By the way, I've used the old term, Greenwich Mean Time, so you can see the connection between the history of navigation and the terms used. Some years ago, most people who use time adopted a new name for GMT, Universal Coordinated Time or UTC (From the French Universal Time Coördinaire.) Today, you're more likely to run into the new UTC on the radio or TV.

Equation of Time

OK, last step. Where do you find the Equation of Time? The Analemma. The Analemma is shaped the way it is so that you can read both the Declination of the Sun and the Equation of Time from one cool shape. The Declination of the Sun is shown above and below the Equator, the Equation of Time is shown left and right. Different maps and globes have different systems of displaying the numbers, but if you look at it carefully, you'll be able to figure it out. Just remember that up and down, the Analemma gives you Sun's Declination, left and right gives you the Equation of Time.

Once you've got the Equation of Time, you'll have something like +15.5 minutes, or -3.0 minutes. You simply add, as in the first case, or subtract, as in the second case, the value from the chronometer's Greenwich Mean Time. The result is Greenwich Apparent Time which is then compared to Local Apparent Noon.

It goes like this: At sea, LAN is observed at 0832 hours, Greenwich Mean Time. (The time on the chronometer.) Remember, LAN means Local Apparent Noon, so it's lunch time as far as your stomach is concerned. First you have to convert the chronometer's clock time to Sun time by applying the Equation of Time. The Nautical Almanac tells us that on this date, the Equation of Time is 08 minutes. (Ships use the more accurate Nautical Almanac, you would use the Analemma.)

$$\begin{array}{r}
 8:32 \quad \text{GMT} \\
 - 0:08 \quad \text{Equation of Time} \\
 \hline
 8:24 \quad \text{GAT}
 \end{array}$$

We recorded LAN at 12:00 local time and that's *later* than 0824 hours Greenwich Apparent Time, so we must be to the *east* of the Prime Meridian. Next we convert the time to degrees of east longitude by calculating the time difference. LAN can be written above or below GAT. Place the larger value over the smaller.

$$\begin{array}{r}
 12:00 \quad \text{LAN} \\
 - 8:24 \quad \text{GAT} \\
 \hline
 3:36
 \end{array}$$

$$\begin{array}{l}
 3 \text{ hours} \quad * \quad 15^\circ/\text{hour} \quad = \quad 45^\circ \\
 36 \text{ minutes} \quad \div \quad 4 \text{ minutes}/^\circ \quad = \quad 9^\circ \\
 [\text{lambda}] \quad = \quad 54^\circ\text{E}
 \end{array}$$

Step by Step

We're now ready to find the position of any school on the face of the Earth.

1. You must establish a shadow source of known height with a clear area to the north so that the shadow can be measured. It doesn't have to be a pole. For example, if a billboard has a pointed feature at its top that casts a sharp shadow, it'll do. You must know its height and the point exactly under it however. A six foot pole will do, but the taller the pole, the better the accuracy. Flagpoles work especially well. If you use a small pole, bury the end so that it doesn't wobble and true it up using a level.
2. You must establish a true north line extending from the base of your pole, flagpole, etc. This is done by determining a *magnetic* north line with a compass and correcting that line for variation so that you can draw a *true* north line. West variation is subtracted from the compass reading, east variation is added. For example, Variation in the Boston area is about 15 degrees west, so the north line is plotted at 345 degrees according to the compass.

$$\text{True North} = 360^\circ - 15^\circ\text{W} = 345^\circ$$

Variation for your area can be found in the legend of any USGS maps or CGS charts. These steps represent the only setup for this activity. You may want to enlist the help

of a surveyor if you have trouble setting the true north line.

3. The purpose of the pole and north line is to allow you to determine the angle of the Sun at the moment that the Sun lies due south of your position. Determining the Sun's angle can be done two ways: you can measure the length of the shadow and together with the known height of the pole, and find the angle from the pole base to the tip of the shadow to the top of the pole using the Pythagorean Theorem. This is the best way if your shadow maker is tall. Ask your math teacher for help with this one if you aren't familiar with the Pythagorean Theorem. If you can reach the top of your shadow maker, you can use a string from the top to the tip of the shadow and measure the angle directly with a protractor. A word of caution, do not grovel on the ground and sight the top of the shadow maker with your eye. The extended exposure to the near sun image is an invitation to retinal burns. Makes the inside of your eyes feel like hot onion rings!
4. To make an observation, start by setting a reliable watch with a second hand to a good time source. Cable TV is good and so are radio sources that include a tone. DJ voice announcements are often approximations. Get in position ten to fifteen minutes before LAN. Because this is not something that most people have done before, I recommend a dry run before you need good results. As the shadow moves toward true north line, take practice height readings. You should set up a graph with time on the baseline and observed altitude on the Y axis. If you plot your observations as time passes, you'll be able to see your consistency improve.
5. You will be recording the *time* of LAN as shown on your watch and either the Sun's altitude angle or the shadow length. Whether you record the angle or length will depend on how you intend to calculate the Sun angle. (See three, above.) Begin recording your readings *before* the shadow crosses the north line. You can mark the readings when the shadow is centered on the north line, but continue recording times and shadow angles or lengths for another five minutes. Typically the height readings are a bit jumpy when plotted on the graph paper. With a straight edge, draw a line through the highest points on the graph and take *that line* as the value for the observed time and height of the Sun.
6. If you were in the British Navy and had sailed from Portsmouth, your Chronometer would have been set to GMT before you left. You obviously set sail from your *classroom* and so your watch is set to *your* time zone, not Greenwich. Before you can do any longitude calculations, you must convert your Local Zone Time, as shown on your watch, to GMT. Each US time zone is earlier than GMT, so converting to GMT is simply a matter of *adding* some number of hours as shown in Table 1:

Time Zone	Standard Time	Daylight Time
Eastern	5 hours	4 hours
Central	6 hours	5 hours

Mountain	7 hours	6 hours
Pacific	8 hours	7 hours

Table 1.

OK First Officers, see if you can determine the position of my School. I'll tell you that the name of the School is Jamestown School, named after our East Coast town. There are lots of Jamestowns in the USA, so you'll need to calculate my position before an atlas will help you. Here are the data that you'll need:

On August 29, 1998, Local Apparent Noon was observed by my First Officer at 16 hours, 47 minutes, Greenwich Mean Time. The observed height of the Sun was 57.5 degrees above the horizon.

Local Apparent Noon = 16:47 GMT
Height of the Sun = 57.5°

From the Nautical Almanac, the First Officer extracts the following. (As you might guess, the Nautical Almanac provides the same information found on the Analemma, but in more detail.)

Declination of the Sun = 9° 10' N
Equation of Time = - 00' 49"

Before we get started, let's take a moment to think about accuracy. The values shown in the Nautical Almanac are much more accurate than your ability to measure Sun height and the time of LAN with a stick. Therefore, the work of calculating to the nearest minute of arc is really a waste of time. This is an important principle in mathematics, keeping your precision place values in line with your original information. To do this, we're going to round off numbers often. Good luck, the solution to the problem is shown below. (Unless Blackbeard the Teacher cut it off to make you think.)

Latitude

$L = 90^\circ - \text{Sun's Altitude} + \text{Declination of the Sun}$
 $L = 90^\circ - 57.5^\circ + 9^\circ\text{N}$
 $L = 41.5^\circ\text{N}$

So let's see what we have. A quick check of the map shows us that I'm not in Jamestown,

Virginia. Can we use the clue that I'm in an East Coast town? Dang! The Coastline turns east and west at L 41.5°N. Could be several Jamestowns at that Latitude. Back to the chart table you go!

Longitude

First we have to get that Greenwich *Mean* Time converted to Greenwich *Apparent* Time which is Greenwich time according to the Sun. So we apply the Equation of Time:

$$\begin{array}{r} 16:47 \text{ GMT} \\ - 0:01 \text{ Equation of Time} \\ \hline 16:46 \text{ Greenwich Apparent Time} \end{array}$$

Next we find the time difference between our position and Greenwich, England. We know that Local Apparent Noon occurs at 12:00 local time and that that is earlier than 16:46 GAT. Our no-brainer tells us that our position is westward of the Prime Meridian:

Local time earlier, position is westward.

To find how far westward, we'll subtract. To make the subtraction easier, we'll set it up with LAN on the bottom because it's smaller than GAT:

$$\begin{array}{r} 16^{\text{h}}:46' \text{ GAT} \\ - 12^{\text{h}}:00' \text{ LAN} \\ \hline 4^{\text{h}}:46' \end{array}$$

All that's left is to convert the time difference into degrees of longitude:

$$\begin{array}{l} 4 \text{ hours} * 15^{\circ}/\text{hour} = 60^{\circ} \\ 46 \text{ minutes} \div 4 \text{ minutes}/^{\circ} = 11.5^{\circ} \\ \text{Adding both gives } [\lambda] = 71.5^{\circ}\text{W} \end{array}$$

You have found my position to be:

$$L \quad 41.5^{\circ}\text{N}, \quad [\lambda] \quad 71.5^{\circ}\text{W}$$

which is slightly west of our school in Jamestown, Rhode Island.

[NOVA Home](#) | [Teachers Home](#) | [TV Schedule](#) | [E-Mail Bulletin](#) | [Help](#) | [Shop NOVA](#)

[Teacher's Guide by Title](#) | [by Subject](#) | [Transcripts](#) | [Credits](#) | [Site Map](#)

[PBS TeacherSource](#)

© | Updated December 2003



How a Sextant Works

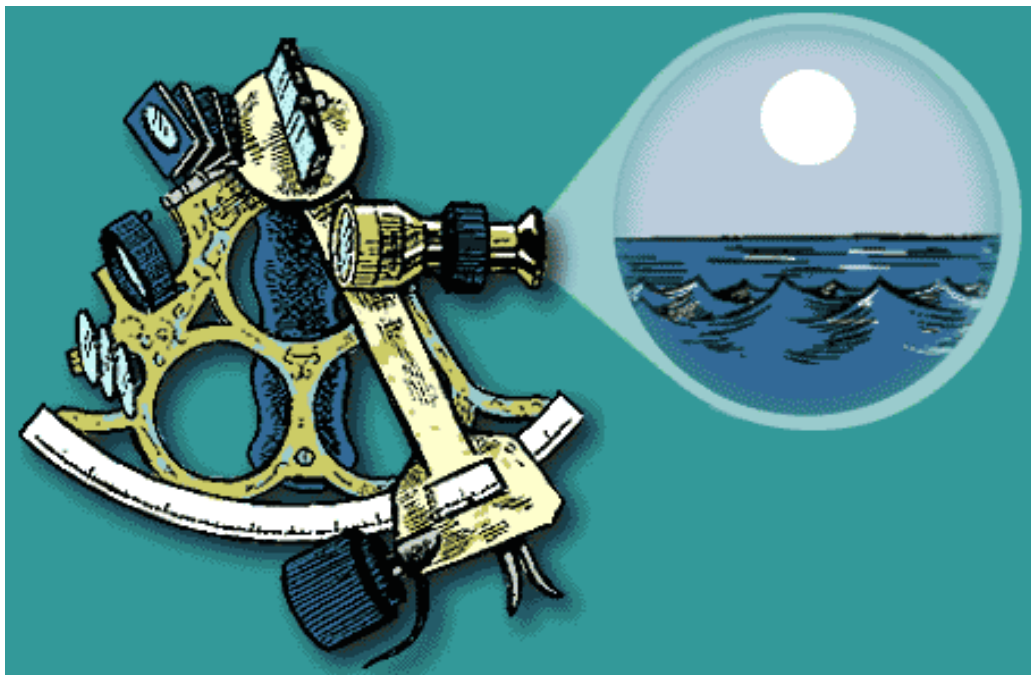

There's nothing mystical or complicated about a sextant. All it is is a device that measures the angle between two objects.

The sextant makes use of two mirrors. With this sextant, one of the mirrors (mirror A in the diagram) is half-silvered, which allows some light to pass through. In navigating, you look at the horizon through this mirror.

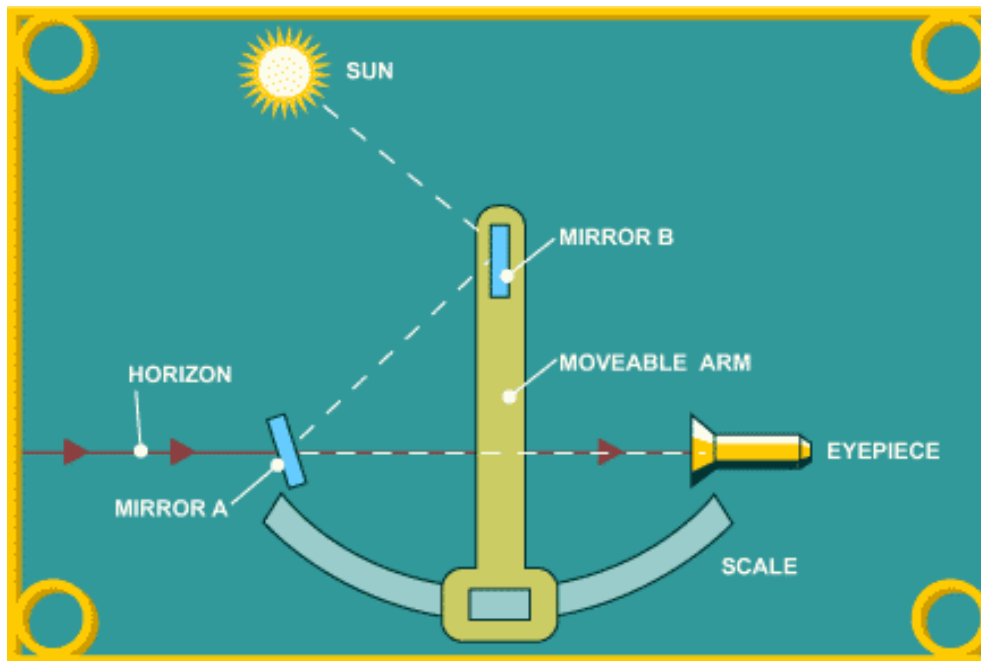

The other mirror (mirror B in the diagram) is attached to a movable arm. Light from an object, let's say the sun, reflects off this mirror. The arm can be moved to a position where the sun's reflection off the mirror also reflects off mirror A and through the eyepiece. What you see when this happens is one object (the sun) superimposed on the other (the horizon). The angle between the two objects is then read off the scale.

What makes a sextant so useful in navigation is its accuracy. It can measure an angle with precision to the nearest ten seconds. (A degree is divided into 60 minutes; a minute is divided into 60 seconds.)

- [Escape from Antarctica](#) (668k)
([Shockwave plugin](#) required)
- [How a Sextant Works](#)
- [Navigation by Sextant](#)

 [Printer-Friendly Format](#)  [Feedback](#)

[Shackleton's Expedition](#) | [Surviving Antarctica](#) | [Explore Antarctic Islands](#)
[Classroom](#) | [Resources](#) | [Transcript](#) | [Teacher's Guide](#)
[Site Map](#) | [Shackleton Home](#)

[Search](#) | [Site Map](#) | [Previously Featured](#) | [Schedule](#) | [Feedback](#) | [Teachers](#) | [Shop](#)
[Join Us/E-Mail](#) | [About NOVA](#) | [Editor's Picks](#) | [Watch NOVAs Online](#) | [To Print](#)
[PBS Online](#) | [NOVA Online](#) | [WGBH](#)

© | Updated February 2002



Navigation by Sextant

There's no way around it: Celestial navigation using a sextant is a complex and involved process that involves a fair amount of calculating, correcting, referring to tables, knowledge of the heavens and the Earth, as well as a lot of common sense. (No wonder it's been so quickly replaced by the satellite-dependent Global Positioning System, or [GPS!](#)) But the basic principles behind celestial navigation are fairly straightforward. Here are a few examples that show how a sextant can be used to find location...



Finding latitude is easy enough. The first thing you need to do is measure the angle between the horizon and the sun when the sun is at its highest point, which is right around noontime on your watch. A quick look at your trusty tables tells you which line of latitude the sun should be above on that particular day. For example, let's say it's noon on December 21, and the sun is directly overhead. Well, on that day the sun is above the Tropic of Capricorn, so your latitude would have to be 23.5 degrees S.

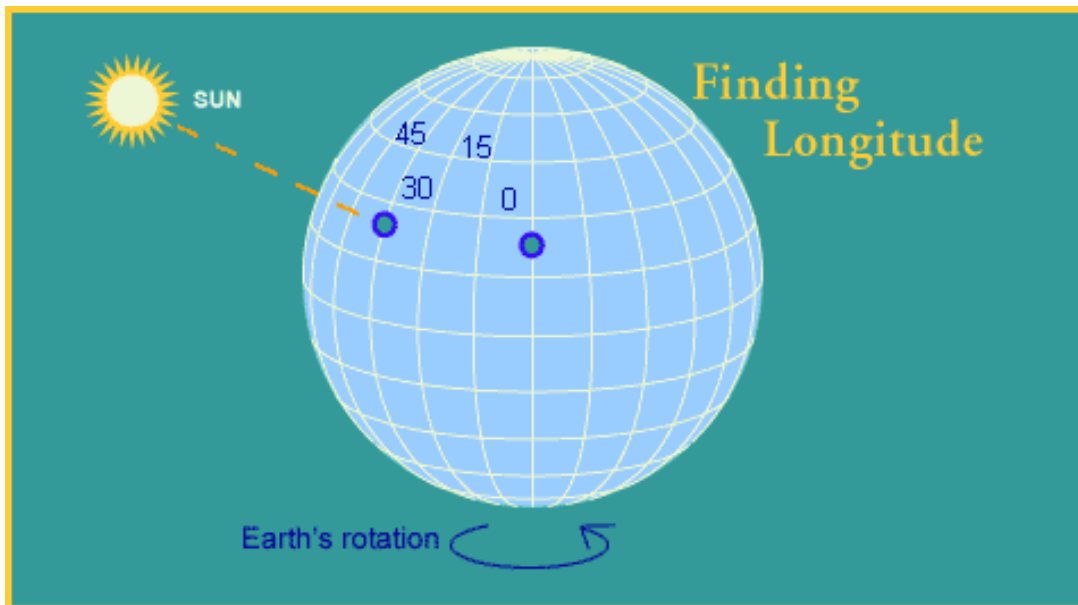

It's a good thing, if you're a navigator, that the Earth spins around at such an even pace. Every hour it moves 15 degrees. This means that if the sun is above the longitude of 0 degrees at noon, one hour later it will be above 15 degrees West. Now if you have a chronometer (this is just a fancy name meaning "extremely accurate clock"), you can find your longitude. Let's say that the sun is directly overhead and your chronometer, which was set to noon when you were at 0 degrees, says it's 3 o'clock. This means that three hours ago the sun was overhead at this latitude at 0 degrees longitude. In those three hours, the sun moved 15 degrees 3 times, or 45 degrees. So you're at 45 degrees West. Of course, the fact that the sun was directly overhead (which very rarely happens) made it especially convenient for finding your longitude, but you could have found your longitude anyway, with the help of your tables.

- [Escape from Antarctica](#) (668k)
([Shockwave plugin](#) required)
- [How a Sextant Works](#)
- [Navigation by Sextant](#)

 [Printer-Friendly Format](#)  [Feedback](#)

[Shackleton's Expedition](#) | [Surviving Antarctica](#) | [Explore Antarctic Islands](#)
[Classroom](#) | [Resources](#) | [Transcript](#) | [Teacher's Guide](#)
[Site Map](#) | [Shackleton Home](#)

[Search](#) | [Site Map](#) | [Previously Featured](#) | [Schedule](#) | [Feedback](#) | [Teachers](#) | [Shop](#)
[Join Us/E-Mail](#) | [About NOVA](#) | [Editor's Picks](#) | [Watch NOVAs Online](#) | [To Print](#)
[PBS Online](#) | [NOVA Online](#) | [WGBH](#)

© | Updated February 2002



[Click Above For Homepage](#)

[Columbus and
Spaceship America :
Their Missions](#)

Each would journey into the unknown.

[Santa Maria and
America](#)

Ships in Route to New Worlds

[The Crews of Santa
Maria and America](#)

Men of Ships and Space : Their Lives and Qualifications

[Naming the Vessels](#)

The Real Story of the Naming of America

[The Voyages](#)

Figure "8s" in Sea and Space

[Dangers on the Oceans
of Earth and Space](#)

Ship Wrecks on Earth and Space

[Solitude in Earth and
Space](#)

Loneliness of the Explorer

What if Columbus had lived in the 20th Century?
How would his account of space exploration differ from
his log of 1492?

COLUMBUS AND AMERICA

Learning Through Comparative Analysis of the Historic Exploration of Earth and Space

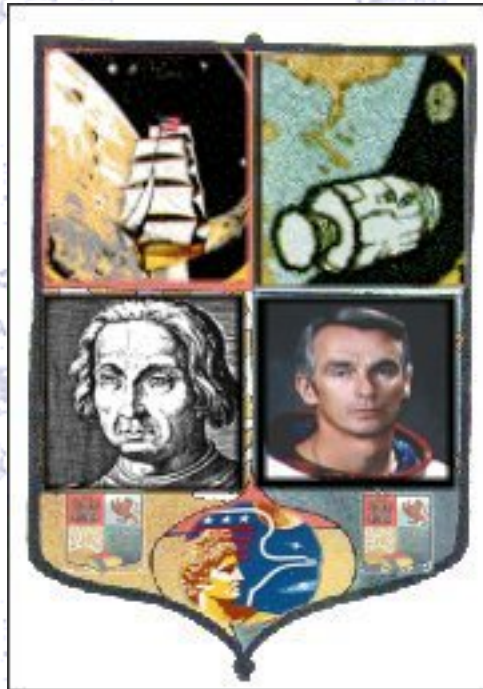

The Space Educators' Handbook

[Space Educators' Handbook](#)

Characteristics of Comparative Analysis

Each page features an aspect of comparison in terrestrial and extra-terrestrial exploration of 1492 and 1972.

[Navigation : Alike and Different](#)

[Columbus and Apollo](#)

[Maps, Logs, and Manuals](#)

[Printing, Essential to Columbus and Apollo 17.](#)

[About Learning Through Comparative Analysis](#)

[What is Comparative Analysis?](#)

[SPACE EDUCATORS' HANDBOOK](#)

This will return you to the SPACE EDUCATORS' HANDBOOK.



[Columbus and America Home Page](#)

Since September 13, 2000, you are visitor number

004498

Last modified: Monday, 13-Sep-00 04:00:00 PM CDT

Author: Jerry Woodfill / NASA, Mail Code ER7, jared.woodfill1@jsc.nasa.gov

[Listing of Characteristics](#)

SPACE EDUCATORS' HANDBOOK RESOURCES

[Space Art...](#) [Space Astronomy...](#) [Space Calendar...](#) [Space Coloring Book](#)

[Space Cool Stuff...](#) [Space Comics...](#) [Space Knowledge...](#) [Space Math Space Movies ...](#) [Space Museum...](#) [Space Sci-Fi](#)

[Space Travelers...](#) [Space Verne Novel](#)

[Space Voluminous Educators Index](#)

Last modified: Monday, 28-Aug-00 04:00:00 PM CDT

Author: Jerry Woodfill / NASA, Mail Code ER7, jared.woodfill1@jsc.nasa.gov

Curator: Cecilia Breigh, NASA JSC ER7

Responsible Official: Charles Gott, NASA JSC ER7

Automation, Robotics and Simulation Division, Walter W. Guy, Chief.

Curator: Cecilia Breigh,
NASA JSC ER7

Responsible Official:
Charles Gott, NASA JSC
ER7

**Automation, Robotics and
Simulation Division, Walter
W. Guy, Chief.**

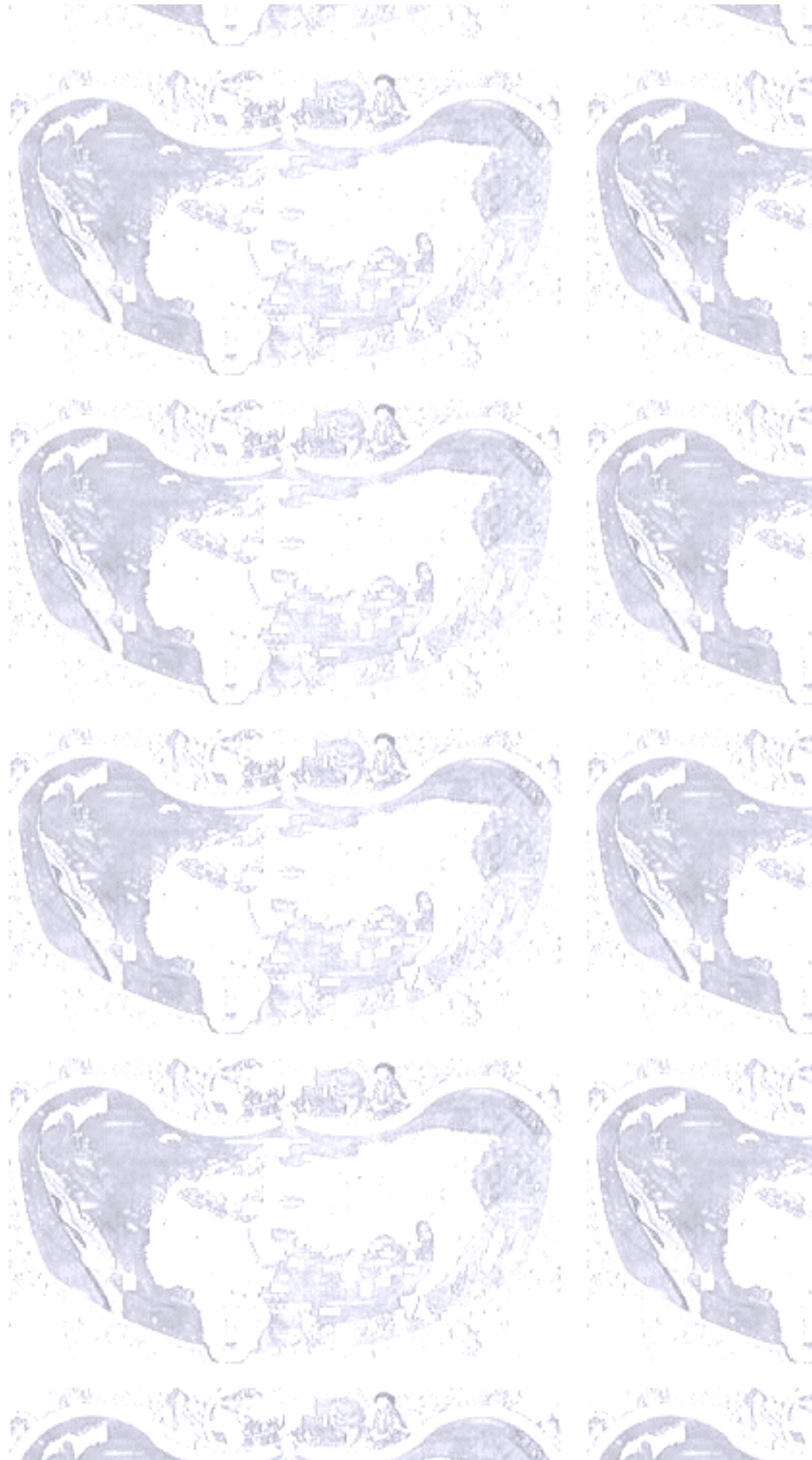

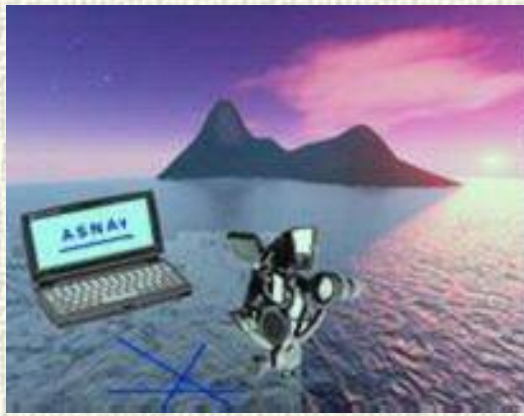

Celestial navigation for dummies

Introduction

The principles of celestial navigation are **simple**. The harder mathematics come in details of calculations, and a computer program like [ASNAv](#) will take care of this for you, so don't be afraid to read this page. It's pleasant to understand how it is possible to find his position on Earth just be looking at a few stars...

The celestial mechanics is precision mechanics. It is possible to calculate the exact position of a heavenly body (star, planet, moon, sun) in the sky at any given time. Knowing the position of the star in the sky, the

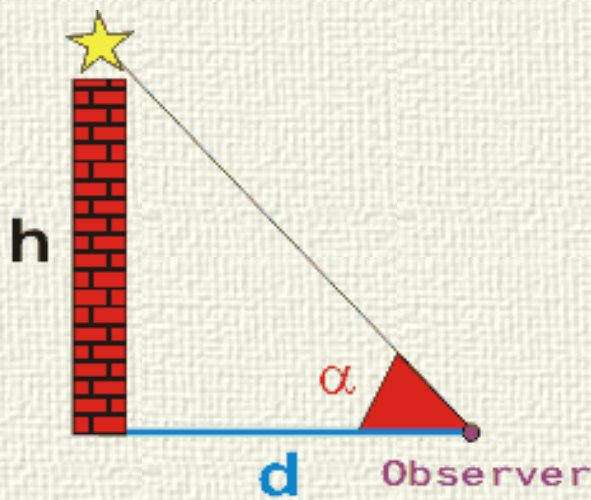

$$\tan \alpha = h / d$$

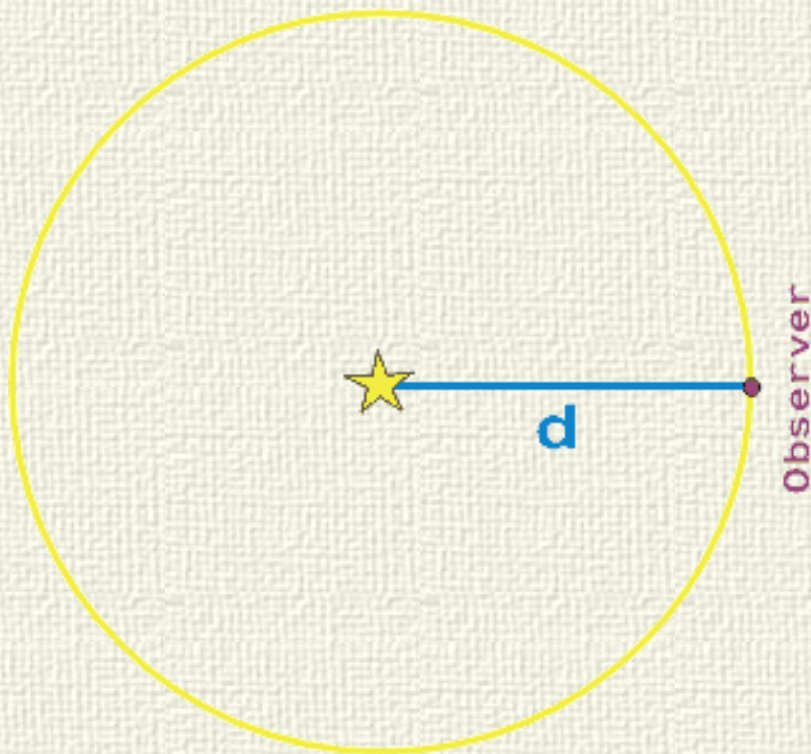

measure of the angle between the horizon of the observer and the star, using a sextant, is enough to determine the observer position in latitude and longitude (in fact, we will see that at least **two** measures are needed).

Let's show this by the example of another situation at sea: imagine you observe a lighthouse from a certain distance. With the sextant, you measure the angle **alpha** corresponding to the height of the lighthouse seen from your position.

If you know the height **h**, you can find your distance **d** from the lighthouse. On a chart, you can draw a circle centred on the lighthouse with a radius **d**. You are somewhere on the circle. This is your *circle of position*.

A second observation gives you a second circle of position. You are at the intersection of the circles of position.

In fact, there is most often 2 intersections but your *estimated position* or a third observation will help you to choose the right one.

If you don't observe a lighthouse but the angle between your horizon and a star, you are doing celestial

navigation. That's it!

Of course, at this stage we need to look a little bit closer at the celestial mechanics to understand how we can calculate the exact position of a heavenly body (star, planet, moon, sun) in your local sky at any given time and which mathematical relation is linking the altitude of a body to a circle of position. Unfortunately, it is not as simple as $\tan(\alpha) = h / d$.

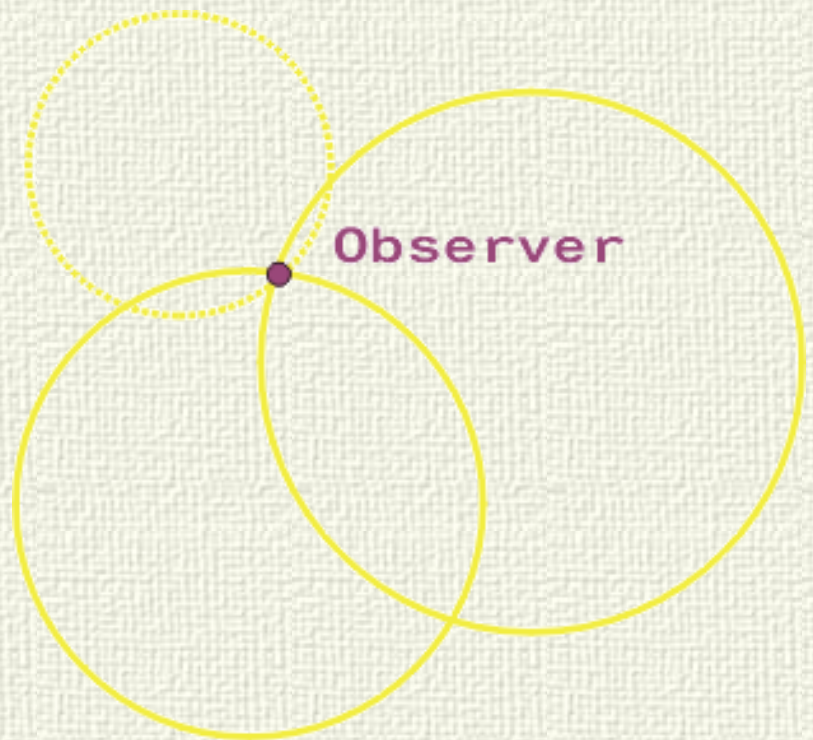

Celestial mechanics - a blueprint

Imagine the Earth in space surrounded by a celestial sphere on which all the heavenly bodies are moving. This is a quite simple representation of the universe, but this is enough for our purposes. We are just poor seamen (correction, I am). The celestial sphere is

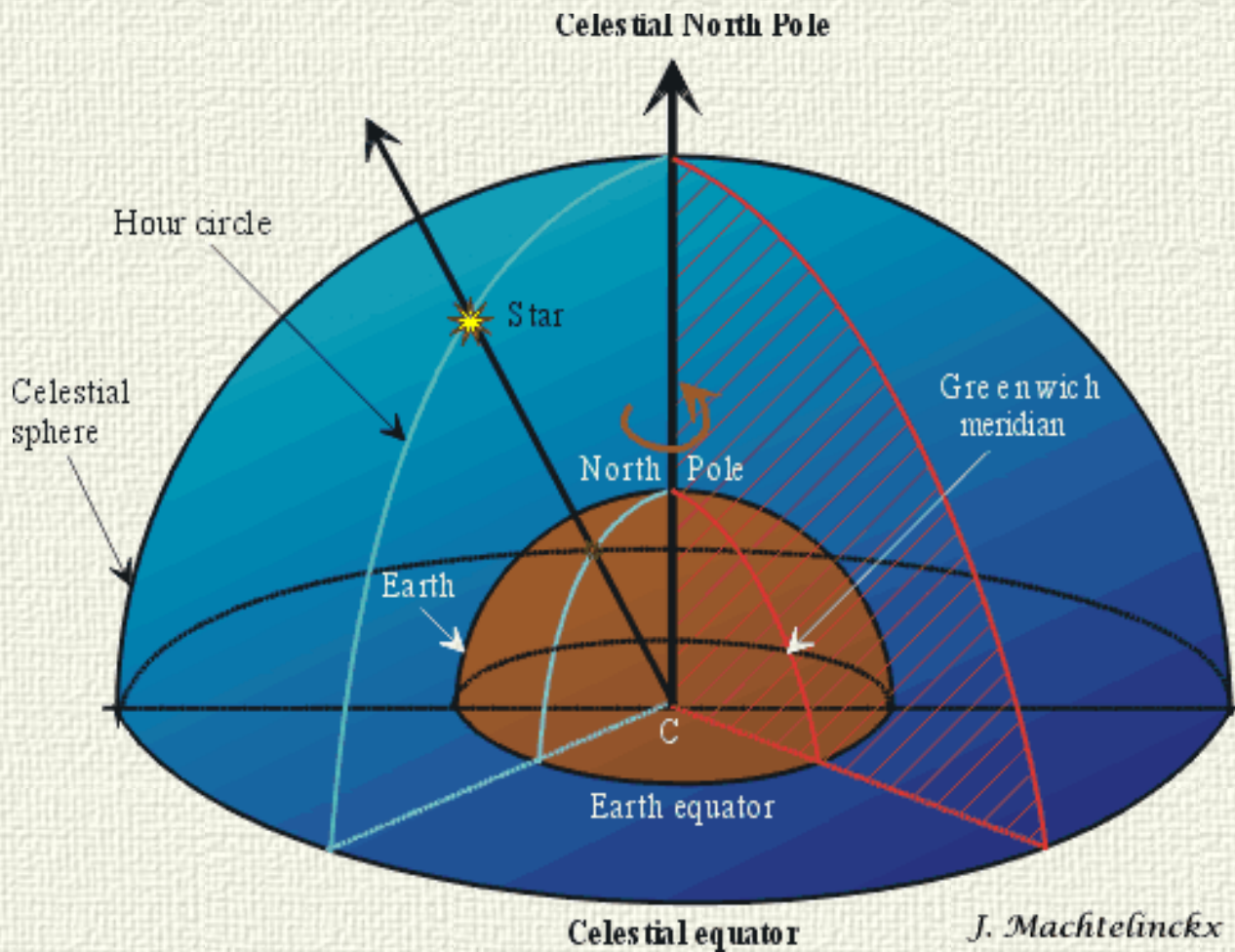

centred on Earth with the celestial equator passing through the Earth equator and the axis Earth centre C to North Pole defining the axis of reference of the celestial sphere. A plan of reference defined on Earth is also used on the celestial sphere: the Greenwich meridian. On the celestial sphere, we show a star S and its hour circle.

The star in the sky is like the lighthouse of your previous example.

[Go back to the ASNAv home page](#)

This Web Site and all contents are copyright © 1999-2004 by Seamanship International. All Rights Reserved.

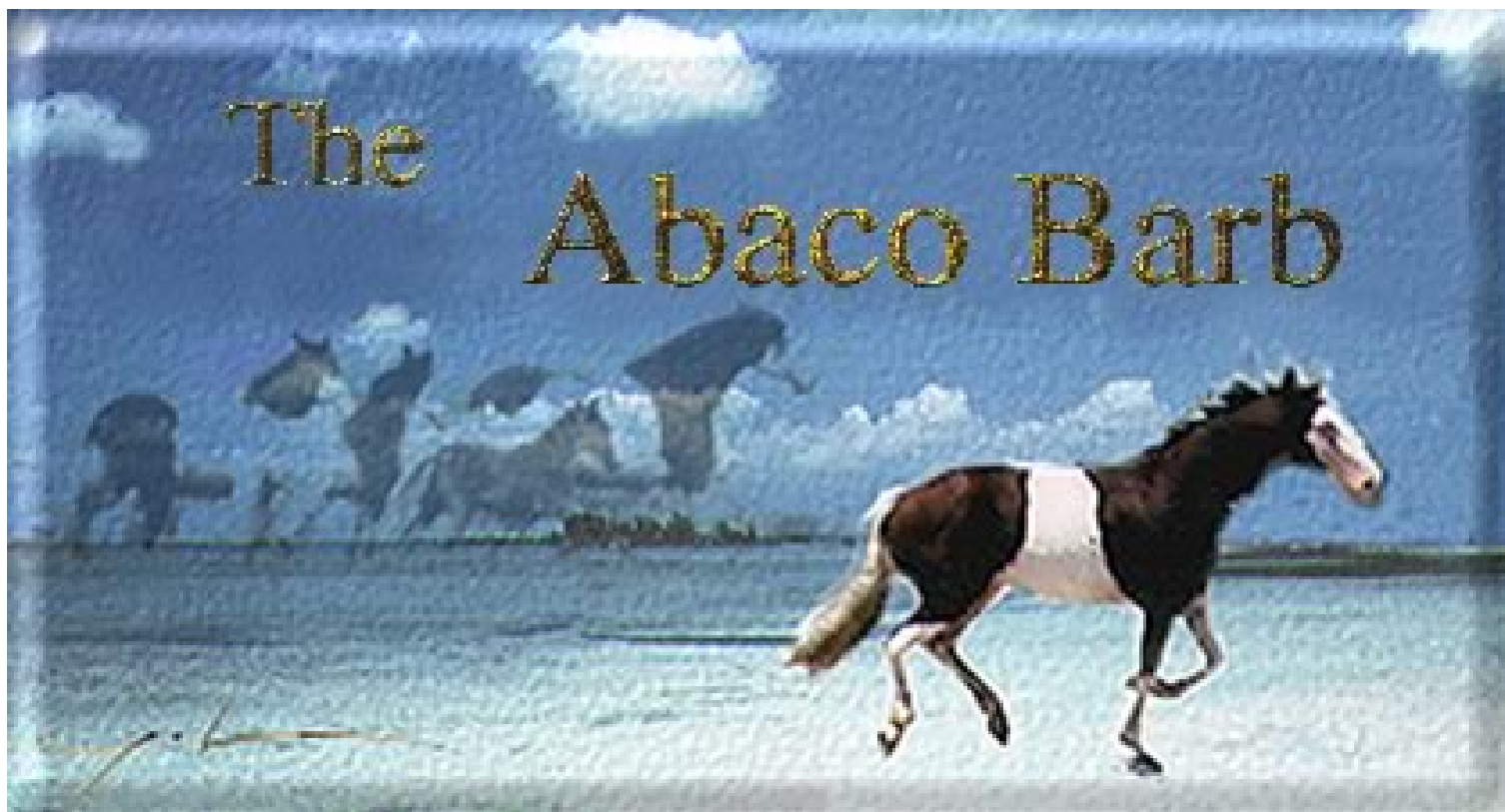

On the sun swept stage of a small island 150 miles off Florida's Gold Coast, a threatened herd of rare and endangered horses have made their official debut to the world. Work begun in 1992 resulted, in August 2002, in having the horses designated a new strain of the critically endangered Spanish Barb breed by the Horse of the America's Registry.

The 12 remaining Abaco Barbs, on the island of Abaco in the Bahamas, are fighting for their lives as inappropriate human intervention and a drastic change in habitat have taken a severe toll. The struggling remnants of a once mighty herd of 200 are facing extinction for the second time in their recently turbulent history. The Government of the Bahamas designated a preserve area for the horses and the mares are now back in their normal habitat. The stallions are waiting for the next expansion of protected area.

This site contains a history of the horses, goals for the future, information on how to help, a newsletter and many other features. For ongoing reports on the horses, see HOOFBELTS, below.

This page is best viewed using Netscape Navigator. [Get the latest version of Netscape now.](#)

[Fund Goals](#)

[Where is Abaco? \(Map\)](#)

[History of the Horses](#)

[Condensed History](#)

[HOOFBEATS - Newsletter](#)

[Video Clips](#)

[About This Site](#)

[Send us E-Mail](#)

How You Can Help

[Visit the Abaco Barbary Horses](#) The horses are now on their Preserve, and you can visit them. If you are coming to Abaco, find out how to make an appointment for a personal tour.

[Gift Shop](#) Choose your items, print an order blank and send a check. Or, [Browse and buy](#) right now, on line, quick and secure transactions with **PayPal**.

[Go Shopping!](#) Visit the **iGive** mall for easy, secure on line shopping at over 240 nationally known stores.

[Wish Lists:](#) What we need, from Equipment to Supplies and Maintenance to Administrative personnel and Volunteers

[Make a Donation](#) right now, while you're on line. Quick and secure with **PayPal**.

[Subscribe](#) You can choose a donation amount and then have easy payments deducted automatically from your account each month. Easy, convenient with **PayPal**.

Sign up with **iGive** and **PayPal** through these links and be set for simple and fast future transactions and many benefits.

Bulletins:

This site updated August 3, 2004

.The HOOFBEATS Newsletter now contains monthly updates on the horses, starting from January, 2003

Arkwild Inc. has 501(c)(3) tax exempt status
Your donations are [tax deductible](#)

Heavenly Mathematics: Cultural Astronomy (GEK1506)



[Adam Schall \(1591-1666\), Imperial Astronomer in Beijing](#)

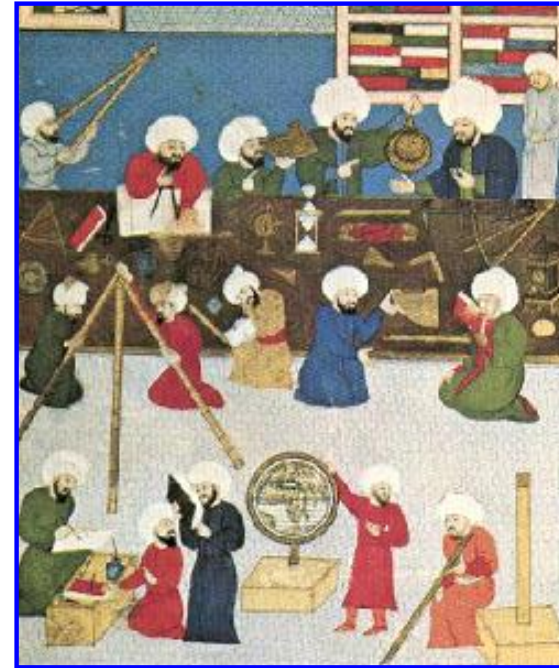

Astronomers at the Istanbul Observatory

Welcome to Heavenly Mathematics: Cultural Astronomy!

Objectives of the Module	Topics to be Covered	Practical Information and Assessment	Course Schedule
IVLE Course Page with Discussion Forum	Recommended Texts	Astronomical Java Applets and Animations	Astronomical Video Clips
Strobel's Astronomy Notes	Stellarium Software		

Course Content

Astronomy and its History	Calendars	The Equation of Time	Ancient Astronomical Instruments
Astrology	Navigation	Cartography	Archaeoastronomy
Cultural Astronomy	Astronomy in Nature		

Additional Information

Lecture Notes	Tutorials and Homework Assignments	Old Exams	Past Homework
Past Projects	Project Topics	References	Good-bye!
Helmer Aslaksen's home page			



Objectives of the Module

The goal of this course is to study astronomy in a cultural context. We will look at questions like: How is the date of Chinese New Year determined? Why do the Muslim and Chinese months start on different days? Will the Moon ever look like it does on the Singapore flag? What date of the year is the earliest sunrise in Singapore? How did ancient sailors navigate?

After taking this course you will become conscious of the motion of the Sun and the Moon and notice and question things you have earlier taken for granted. You will appreciate mankind's struggle through the ages and throughout the world to understand the mathematics of the heavens.

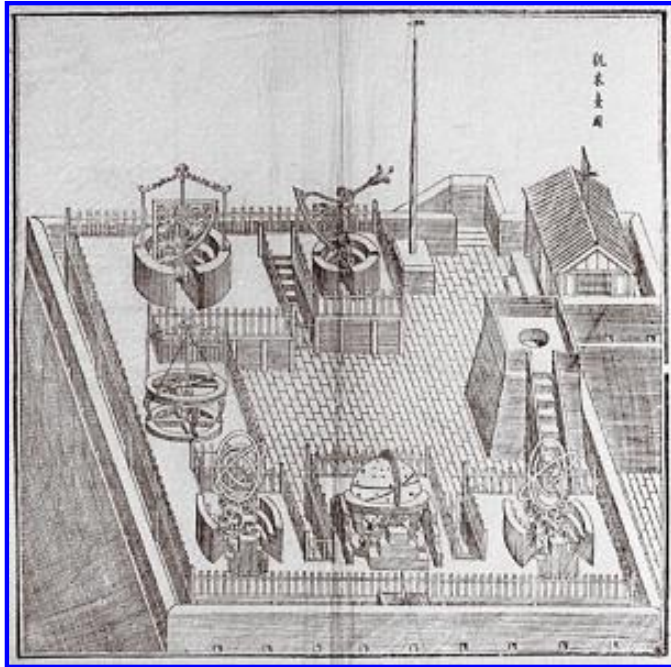

[Astronomical instruments in the Imperial Observatory in Beijing made by the Jesuit missionary Ferdinand Verbiest, 1670](#)

Topics to be Covered

We start by discussing the motion of the Sun, Earth and Moon and other fundamental concepts of [astronomy and its history](#). In Singapore, we use the Gregorian, Chinese, Islamic and Indian [calendars](#) for determining the public holidays. [The equation of time](#) is crucial for understanding the time of sunrise and sunset in the tropics. We also look at [ancient astronomical instruments](#) like the astrolabe and armillary spheres. [Astrology](#) was important in the past, and we explore the ideas behind it. Developments in [navigation](#) and [cartography](#) (map making) have been important in world history. We discuss [archaeoastronomy](#) (the use of astronomy in archaeology), [cultural astronomy](#) and [astronomy in nature](#).



[Brian Greig's astronomical instruments for sale at the Melbourne Arts Centre Sunday Market](#)

Practical Information and Assessment

This course is one of the new [General Education Modules](#) at the NUS.

There will be three hours of lectures and one hour of large group tutorial each week. The time slots in 2003/2004 Semester 1 are Tuesday and Friday 2-4 in LT32. I will go from 2.00 to 2.50, take a 10 min break and go from 3.00 to 3.40. There will be two tutorial groups. The last session on Friday will be a large-group tutorial, and there will be another tutorial group on Tuesday 4-5 in LT 23. You only need to attend one of these.

I use a cordless microphone and walk around in class and ask questions. But don't worry, I only ask easy questions! I also like to create physical demonstrations to illustrate the concepts, and I often need “volunteers” for this. I am not afraid of looking silly, and I hope you are not either!

If you send me e-mail, please use the module code GEK1518 in the subject. Otherwise you may end up in my spam folder. This is especially important if you use a non-NUS e-mail address.

The final exam counts 40% of your grade. You have to do a project that counts 40%. The projects are done in groups of four to six students. There will be also be two homework that count 10% each.

Please do the homework in the same group as you do the project. If you are planning to do a very special topic, and you're having a hard time finding somebody interested in it, I MAY also approve individual projects or groups of two or three. The chances of me approving such requests are best if you approach me early.

The project proposal is due Friday 12/9. The project itself is due on Friday 17/10. The homework about the Sun is due on Friday 3/10 and the homework about the Moon is due on Friday 10/10. The exam will be on Wednesday 19/11.

Many topics will only be touched upon in lectures, and you may explore them further on your own in the projects. I have a list of possible [topics](#), but I also

encourage you to propose your own topics and send them to me for approval. I hope that you will be able to find something that you are enthusiastic about. I prefer projects with a cultural astronomy focus, but if you are passionate about a pure astronomy project, then that's OK, too.

The project can be a normal paper project, a web page, a physical model or a combination of all these. I don't have any set rules about length or scope of the project, but I have some [guidelines](#).

The project proposal should include the title, the names of the members of the group, a brief outline, and a list of the main references. One or two pages is enough.

Please submit the proposal, the project and the homework in both hard copy in class and soft copy in the IVLE workbin. I prefer to read the hard copy, so if you create a web page, please print out a hard copy, too. I realize that the print out may not do full justice to your web page, but it will give me time to read the text before I look at your page. If you have animations or other things that you can't print out, please include a note where you indicate which parts of the web site I should look more closely at.

If the project is a web page and you have a server to put it on, you can just submit a file with the URL. However, I would appreciate it if you could also give me the files on a CD, or zip the files into one file and upload.

If your project includes a physical model, please let me know if you want it back. Some of them I may ask to keep, but some of them are too bulky, and I must either throw them away or return them to you quickly.

I have a page with links to some [past projects](#).

There will be two homework. One homework is about the Sun. You will study the rising (or setting) position of the Sun over the course of the module and try to determine the date of the fall equinox. The second homework is about the Moon. You have to make five observations of the Moon in the course of a lunar month. The observations should focus on what, where and when. What does the Moon look like? Where in the sky did you see it? When did you see it? Don't worry about precision in your observations. All you have to do is to convince me that you actually made the observations and that you understand what you saw. Here are some highlights from [past homework](#).

Together with [CITA](#), I have developed interactive [Java applets](#) and recorded [video clips](#) that I hope will help you understand the geometrical concepts.

Course Schedule

Week 0	Orientation
Week 1	First week of lectures
Week 2	
Week 3	Tutorial 1

Week 4	Tutorial 2
Week 5	Project proposal due, Tutorial 3
Week 6	Tutorial 4
Week 7	Tutorial 5
Week 8	Sun Homework due, Tutorial 6
Week 9	Moon Homework due, Tutorial 7
Week 10	Project due, Tutorial 8
Week 11	Tutorial 9
Week 12	Tutorial 10
Week 13	Last week of lectures, Tutorial 11
Reading Week	



[Royal Observatory Greenwich](#)

[IVLE Course Page](#)

I have a [course page](#) at [IVLE, the Integrated Virtual Learning Environment](#) at the NUS. It has a discussion forum that I encourage you to use. (All the other information at IVLE is just taken from this page.)



Recommended Texts

Unfortunately, there's no single text that is suitable. Maybe I'll try to write one myself? But the closest is [The Ever-Changing Sky, A Guide to the Celestial Sphere](#) by [James B. Kaler](#). However, it goes into a lot more detail about astronomy than we will cover. The level of astronomy I expect you to learn is comparable to the first chapter and the appendix of [The Copernican Revolution, Planetary Astronomy in the Development of Western Thought](#) by Thomas S. Kuhn. For convenience, the main reference for the first part will be [Strobel's Astronomy Notes](#) on the web.

I have compiled a list of additional [references](#). In addition to the books by Kaler and Kuhn, I've also placed [The History and Practice of Ancient Astronomy](#) by James Evans and [Calendrical Calculations: The Millennium Edition](#) by Nachum Dershowitz and Edward M. Reingold on RBR in the Science Library.



[Orrery by Brian Greig](#)

Astronomical Java Applets and Animations

Together with Tey Meng Khoon and Frederick H. Willeboordse of [CITA](#) (Centre for Information Technology and Applications), I have developed interactive Java applets that I hope will help you understand the motion of the Earth, the Sun and the Moon.

You will notice that a lot of the applets are somewhat similar. They show the same thing, but we're trying to emphasize different aspects or points of view in each one.

You can get the Java Runtime Environment (JRE) at java.com. If you prefer to view the applets off-line, you can [download](#) them. Just unzip astro-applets.zip, and open astro-applets.html in your browser.

- [The Motion of the Earth Around the Sun](#). This is a pretty basic applet showing the Earth moving around the Sun. But pay attention to how you can determine the equinoxes and solstices by looking at the position of the Earth's axis, and how the declination changes. **RealVideo**.
- [The Apparent Motion of the Sun](#). This shows the “spiral of circles”. **RealVideo**.
- [The Apparent Motion of the Sun at Different Latitudes](#). Now you can see how the “spiral of circles” changes depending on your latitude. **RealVideo**.
- [The Apparent Motion of the Sun at Different Times of the Year](#). This is one of my favorite applets, that I use over and over again in my class. If you really understand this applet, you will get a good grade in my class! **RealVideo**.
- [The Motion of the Sun Along the Ecliptic](#). Another of my favorites. If you really understand this applet, you have arrived! **RealVideo**.
- [A Vertical Sundial](#). One of the points of this applets, is to make you understand why you shouldn't make a vertical sundial. (Unless you are a polar bear or a penguin!) **RealVideo**.
- [The Astrological Houses at Different Latitudes](#). Astrologers like to talk about your ascendant and other “houses”. Unfortunately, the house system depends very much on your latitude. Very few astrologers understand how this works. If you want to understand this, get the book [Making Sense of Astrology](#) by Ronny Martens, Tim Trachet and study this applet.
- What does the waxing or waning Moon look like in different parts of the world in the course of the year? This is something that confuses a lot of people! [A simplified model of the tilt of the waxing or waning Moon in different parts of the world](#) ignores the tilt of the ecliptic, and assumes that the Sun and the Moon both move along the celestial equator. You may want to start out with this applet.
- If you studied the previous applet, you are now hopefully ready for the real thing. [What does the waxing or waning Moon look like in different parts of the world in the course of the year?](#)

The last two applets are related to the page [What Does the Waxing or Waning Moon Look Like in Different Parts of the World?](#)



[Equatorial \(left\) and ecliptic \(right\) armillary spheres in the Imperial Observatory in Beijing made by the Jesuit missionary Ferdinand Verbiest, 1670](#)

Video Clips

Together with Keith Phua Kuan Wee of [CITA](#) (Centre for Information Technology and Applications), I have recorded video clips to help you understand the material. The clips are available in three formats:

- [RealVideo](#) SureStream, click the link to stream. The quality and file size of the clip is determined by the preference settings in your RealPlayer.
- [RealVideo](#) LAN/150Kbps, right-click to download.
- [QuickTime](#), click to stream, right-click to download.

I have recorded video clips to explain the [Java applets](#) and [Strobel's Astronomy Notes](#).

Strobel's Astronomy Notes

[Nick Strobel](#) of [Bakersfield College](#) has written a wonderful set of [Astronomy Notes](#) for his introductory astronomy course. His chapter on [Astronomy Without a Telescope](#) is very relevant background for this module. I have recorded video clips with annotations to some of the sections of the first chapter of Strobel's

notes.

Here is the table of content for the first chapter of Strobel's [Astronomy Notes](#) with links to my video clips.

- [Astronomy Without a Telescope](#).
- [Celestial Sphere Defined](#): **RealVideo**, [RealVideo SureStream](#), [RealVideo LAN/150Kbps](#), [QuickTime](#).
- [Angles](#)
- [Reference Markers](#): **RealVideo**, [RealVideo SureStream](#), [RealVideo LAN/150Kbps](#), [QuickTime](#).
- [Motion of Our Star the Sun](#): **RealVideo**, [RealVideo SureStream](#), [RealVideo LAN/150Kbps](#), [QuickTime](#) .
- [Coordinates](#): **RealVideo**, [RealVideo SureStream](#), [RealVideo LAN/150Kbps](#), [QuickTime](#).
- [Time and Seasons](#): **RealVideo**, [RealVideo SureStream](#), [RealVideo LAN/150Kbps](#), [QuickTime](#).
- [Time Zones Equation of Time](#): **RealVideo**, [RealVideo SureStream](#), [RealVideo LAN/150Kbps](#), [QuickTime](#).
- [Seasons](#)
- [Sections Review](#)
- [Motions of the Moon](#): **RealVideo**, [RealVideo SureStream](#), [RealVideo LAN/150Kbps](#), [QuickTime](#).
- [Phases and Eclipses](#)
- [Eclipse Details: Lunar Eclipse](#)
- [Planetary Motions](#)



Stellarium Software

I recently discovered the wonderful, freeware [Stellarium Astronomy Software](#) available for Windows, Linux/Unix and MacOSX.

Astronomy and its History

How can we use the celestial sphere to understand the movement of the Sun, Moon and stars across the sky? Observing the sky has always been an important part of human civilization. We give a summary of some basic facts from spherical astronomy. One of my students, Viduranga Yashasui Waisundara, has written a beautiful poem about this, called [If I were God](#).

There are a lot of [Myths about the Copernican Revolution](#). Many people whose main interest is philosophy of science, but with little knowledge of astronomy or history of science, have written extensively about it. Unfortunately, much of what they say is incorrect.



[Tycho Brahe](#) (1546-1601)

Multimedia

- Please check out my [Astronomical Java Applets and Animations](#) and [Astronomical Video Clips](#).
- [Demonstrations and Animations for Teaching Astronomy - D A T A](#) at Department of Astronomy - University of Illinois at Urbana-Champaign.

Course pages

- [Nick Strobel](#) of [Bakersfield College](#) has written a wonderful set of [Astronomy Notes](#) for his introductory astronomy course. His chapter on [Astronomy Without a Telescope](#) is very relevant background for this module. I have recorded [RealVideo](#) [video clips](#) with annotations to some of the sections of the first chapter of Strobel's notes.
- The course [Introduction to Astronomy](#) by Scott R. Anderson has great animations.
- The course [Math & Culture, Late Renaissance Thought and the New Universe](#) by Dorothy Wallace & Scott Sciortino of Dartmouth College is very interesting.



[The Meridian Line at Greenwich](#)

Astronomical Institutions

- For general astronomy info, my favorite is the web site of the [Astronomical Applications Department of the U.S. Naval Observatory](#).
- [The Royal Observatory Greenwich](#). Their information leaflets on [Timekeeping](#) are very good.
- [Museum of the History of Science, University of Oxford](#) has many interesting exhibitions.

General Astronomy Sites

- Wolfgang R. Dick's [History of astronomy](#) page.
- [Starry Messenger](#) by [David Chart](#) of the [Department of History and Philosophy of Science](#) of the University of Cambridge.
- [Physics and astronomy applets](#) by Juergen Giesen.
- [Phil Plait's Bad Astronomy: The Home Page](#).

- [Basic Celestial Phenomena](#) by Kerry Magruder.
- [Astronomy & Culture](#) is part of [Astronomy Homework Help](#) by [Gary Agranat](#).
- J.P. van de Giessen's [Astronomical Books Online](#) contains a link to my page on [The Mathematics of the Chinese calendar](#).
- [Tons O' Astronomy Links](#) by [Joe Heafner](#).

Singaporean Astronomy Related Sites

- [The Astronomical Society of Singapore](#).
- [The Singapore Science Centre](#).
- [NUS Astronomical Society](#).

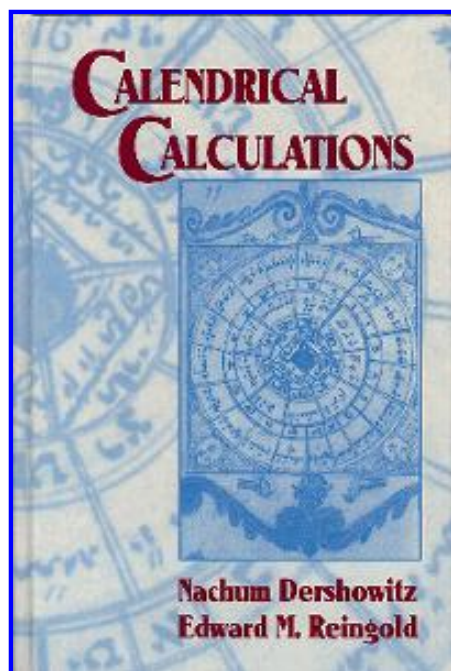

Calendars

How is the date for Chinese New Year, Hari Raya Puasa and Deepavali determined? Singapore is unique in that we use four different calendars for determining the date of the public holidays. Seven of our eleven public holidays move, and we study the rules for Chinese New Year, the two Hari Rayas, Deepavali, Vesak Day and Good Friday. The exact rules are very complex, but the basic ideas are simple. We give two simple rules of thumb that determine the date for Chinese New Year with a margin of error of one day. I have written a set of lecture notes on [The Mathematics of the Public Holidays of Singapore](#).

You will also see why both [Hari Raya Puasas](#) in 2000 are celebrated one day earlier than they would have been if MUIS had relied on sightings or scientific criteria.

Why is it difficult to determine the Islamic prayer times in Northern Europe? This is an interesting astronomical problem, which very few people understand.

What are leap seconds? This requires understanding some delicate points in the definition of atomic time.



Chinese astronomers determining the summer solstice

[General Calendar Info](#)

- I have a page on [Calendars in Singapore](#). It contains a paper I have written about [The Mathematics of the Chinese Calendar](#). I have also written a shorter introduction called [When is Chinese New Year?](#). This paper won a fourth prize in the [Fifth Annual Boeing Writing Contest](#), which is organized by the [Griffith Observatory](#). The article will appear in the [Griffith Observer](#). I have also written a set of lecture notes on [The Mathematics of the Public Holidays of Singapore](#).
- Honours project on [Calendars in Singapore](#) by my student Rachel Lee Tang Hwee.
- The most authoritative reference on calendars is the book [Calendrical Calculations](#) by Nachum Dershowitz and Edward M. Reingold of the Department of Computer Science at the University of Illinois at Urbana-Champaign. If you need a calendar conversion program, the place to go is their [Calendar Applet](#).
- Before the book by Dershowitz and Reingold, the chapter about [Calendars](#) by L. E. Doggett in the “Explanatory Supplement to the Astronomical Almanac” was the standard reference.
- [The Calendar FAQ](#) by Claus Tøndering.
- [Calendars Through the Ages](#) is part of [WebExhibits](#).
- The Worldwide Holiday & Festival Site (<http://www.holidayfestival.com/>) was very comprehensive. (Broken link. Can anybody please help?)
- [The Calendar Zone](#).
- [CalendarHome.com](#).
- [Time-reckoning in Iceland before literacy](#) by Þorsteinn Vilhjálmsson.



[Chinese sundials from the Adler Planetarium](#)

[The Chinese and other East Asian Calendars](#)

- I have a page on [The Chinese Calendar](#). It contains a paper I have written about [The Mathematics of the Chinese Calendar](#).
- Undergraduate research project on [The Chinese Calendar of the Later Han Period](#) by my students Kuan Shau Hong and Teng Keat Huat.
- Undergraduate research project on [Calendars, Interpolation, Gnomons and Armillary Spheres in the Work of Guo Shoujing \(1231-1314\)](#) by my student Ng Say Tiong.
- Undergraduate research project on [Strings of Long Months and Short Months in the Chinese Calendar](#) by my student Zhang Jieping.
- Zhuo Meng's [Make Your Own Chinese Calendar](#) is a wonderful tool!
- The [Western-Chinese Calendar Converter](#) at www.mandarintools.com.
- Harold C. Hill, Department of East Asian Languages and Literatures, Washington and Lee University, has a very interesting page on <http://www.wlu.edu/~hhill/calendar.html> about The cyclical calendar. (Broken link. Can anybody please help?)
- [The Lunar Calendar in Japan](#) by Steve Renshaw and Saori Ihara is the best source for information about the Japanese calendar.
- [Vietnamese lunar calendar conversion](#) by [Ho Ngoc Duc](#) of Institute of Informatics, University of Leipzig.

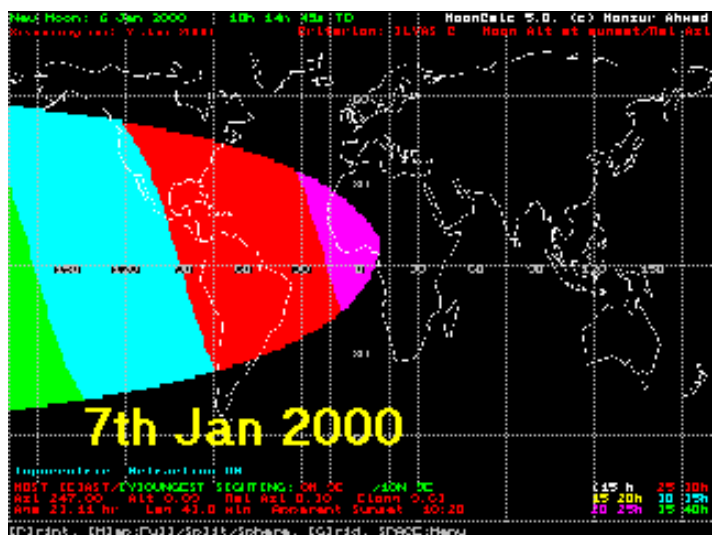

[MoonCalc](#) image

[The Islamic Calendar](#)

- I have a page on [The Islamic Calendar](#), which contains additional links. You will see why both Hari Raya Puasas in 2000 are celebrated one day earlier than they would have been if MUIS had relied on sightings or scientific criteria.
- Undergraduate research project on [Lunar Visibility and the Islamic Calendar](#) by my student Leong Wen Xin.
- [Astronomy for Islam](#) by Khalid Shaukat is a great site for information about the Islamic calendar.
- [Dr. Manzur Ahmed](#) is the author of [MoonCalc](#), the leading lunar visibility and Islamic calendar software. I have a local copy of [MoonCalc 6.0](#).
- [Crescent Moon Visibility and the Islamic Calendar](#) from the [Astronomical Applications Department of the U.S. Naval Observatory](#).

- [Ramadan](#) from [The Royal Observatory Greenwich](#).
- [Crescent Section](#) from the [Jordanian Astronomical Society](#). Their section on [The Actual Saudi Dating System](#) is essential reading!
- [Islamic Crescents' Observation Project](#).
- [Moon Research Centre \(U.K\)](#). The section on [Policies Adopted in Britain by Muslims in Celebrating Islamic Festivals](#) is essential reading!
- [Crescent Sighting](#) from the World Federation.

[The Indian Calendar](#)

- I have a page on [The Indian Calendar](#).
- Honours project on [Indian Calendars](#) by my student Leow Choon Lian.
- Undergraduate research project on [Indian Calendars: Comparing the Surya Siddhanta and the Astronomical Ephemeris](#) by my student Daphne Chia.

Easter

- [The Date of Easter](#) from the [Astronomical Applications Department of the U.S. Naval Observatory](#).

Time

- [Leap Seconds](#), from the [Time Service Department, U.S. Naval Observatory](#).



[Analemma picture by Dennis di Cicco](#)

[The Equation of Time](#)

I have a separate web page on [Which Day Does the Sun Rise Earliest in Singapore?](#) Singapore lies almost on the equator, so most people would expect the Sun to rise at more or less the same time each day of the year. In fact, the sunrise time varies between 6.46am and 7.17am, with the earliest sunrise on November 1 and the latest on February 9. In the same way, the sunset time varies between 6.50pm and 7.21pm, with the earliest sunset on November 5 and the latest on February 13. The difference between the earliest and latest sunrise is 30 minutes, but the difference between the longest and shortest day is only 8 minutes. The key to understanding this is the [analemma](#), which is a graphical representation of the equation of time. The famous picture by Sky & Telescope's Dennis di Cicco records the Sun's position in the sky at the same time of day on 45 different dates throughout the year.



This is also related to the concept of time zones. As you can see from the [map](#), Singapore and West Malaysia are in the “wrong” time zone! For more details, please see my page [Why is Singapore in the “wrong” time zone?](#)

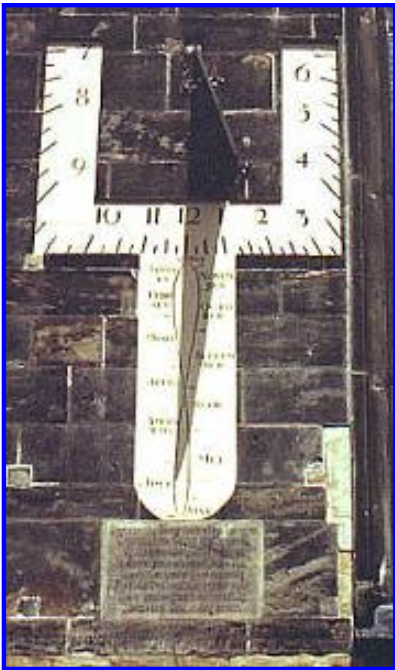

[Sundial in Enschede, Netherlands, 1836, photo by Fer J. de Vries.](#)

The Equation of Time

- I have recorded a video clip that explains this picture: [RealVideo](#), [RealVideo SureStream](#), [RealVideo LAN/150Kbps](#), [QuickTime](#).
- I have a page on [Sunrise and Sunset Times in the Tropics](#). Most books on astronomy are written from a “high-latitude” point of view; instead I take a tropical point of view. You will learn how to prepare a table of sunrise and sunset times for your location.
- I strongly recommend the [analemma.com](#) site.
- You can order a copy of Dennis di Cicco's famous analemma [picture](#) from [Sky & Telescope](#).
- [Sky & Telescope](#) used to have a great comic strip called SkyWise. One month SkyWise discussed [Latest Sunrise, Earliest Sunset](#). [Sky & Telescope](#) no longer has a free archive, but you can [buy](#) the article or look it up in a library.
- For great graphics, see the site by Andrew Marsh at The School of Architecture and Fine Arts at The University of Western Australia (<http://fridge.arch.uwa.edu.au/topics/thermal/sun/sunpos.html>). (Broken link. Can anybody please help?)
- If you need to do computations, there is a handy table of the equation of time and the Sun's declination on the [Daily Sun Data](#) at [Tony Helyar's Home Page](#)
- [The Analemma](#) by Jon Kahl of University of Wisconsin-Milwaukee.
- [Analemma, my Analemma](#) by Douglas Dodds.
- [Sundials on the Internet - the Equation of Time](#).

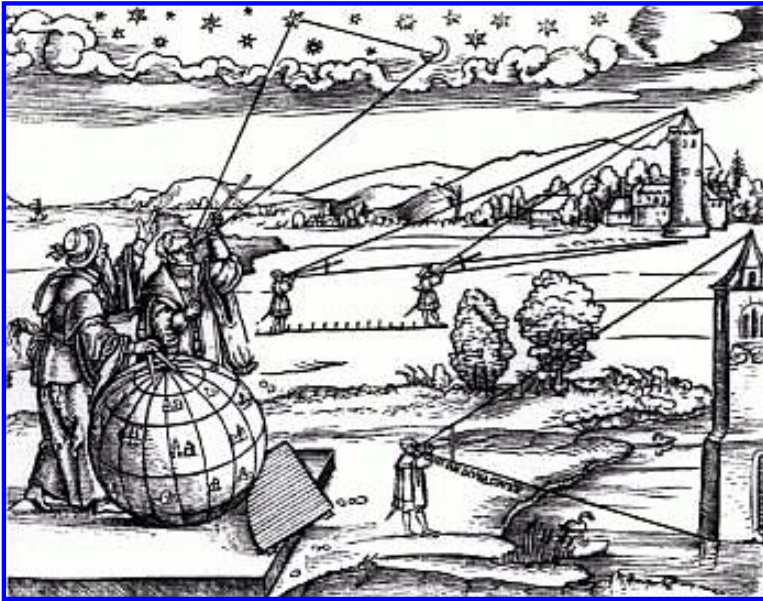

[Cross-staff used for computing lunar distance and height of buildings](#)

Ancient Astronomical Instruments

Why do sundials look different in Singapore and Beijing? We study the theory behind sundials and show how to construct an accurate sundial for any latitude. There are two nice sundials in Singapore. One is in the Botanical Gardens and one in [Marina City Park](#).

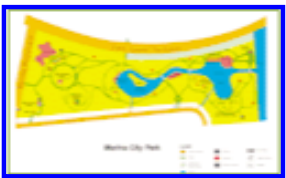

[Map of Marina City Park](#)

Four common types of sundials are the equatorial, armillary, horizontal and vertical sundials.



[Equatorial sundial](#)



[Armillary Sundial at City Hall, Ruurlo, photo by Frans W. Maes.](#)



[Horizontal sundial by Harriet James](#)



[Vertical sundial by Harriet James](#)

For telling the time at night, you can use a nocturnal.



Nocturnal

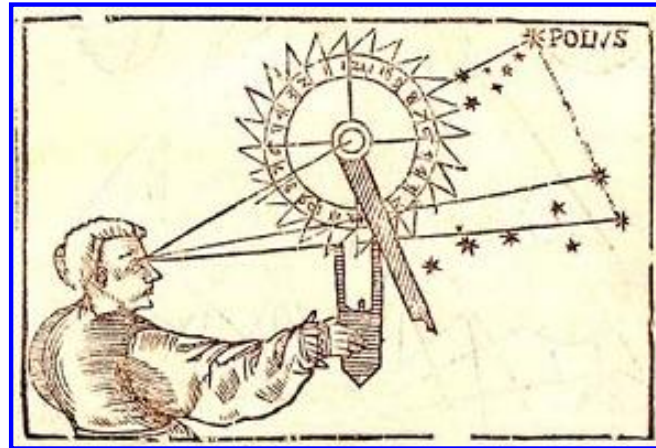

Nocturnal

The quadrant is a simple tool for determining latitude.



Quadrant

The astrolabe was made famous by Arab astronomers, and can be thought of as an analog astronomical computer. We discuss the difference between an astrolabe and a mariner's astrolabe.



[Astrolabe by Norman Greene](#)



[Mariner's astrolabe by Norman Greene](#)

There's a lovely Persian astrolabe from 17th century at the [Asian Civilisations Museum in Singapore](#).



[Brass astrolabe, 17th century, Persia, Asian Civilisations Museum's collection, Singapore](#)

Geoffrey Chaucer, the author of Canterbury Tales wrote a [Treatise on the Astrolabe](#) in 1391.



We then look at the cross-staff and the back staff.



[Cross-staff](#)

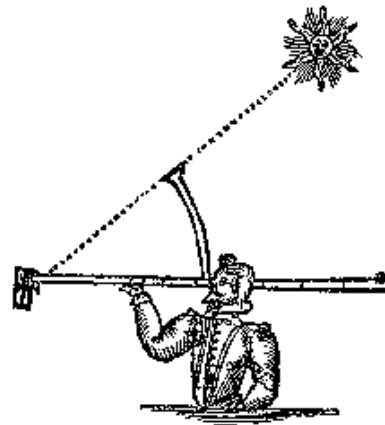

Backstaff

We will compare the relative advantages of the quadrant, mariner's astrolabe and cross-staff.

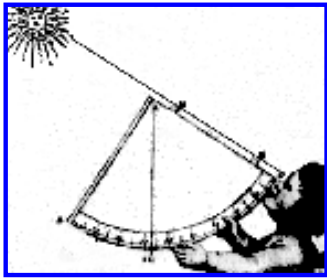

[Quadrant](#)

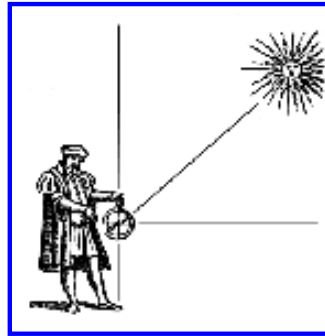

[Mariner's astrolabe](#)

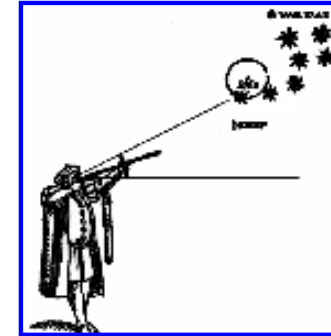

[Cross-staff](#)

The Chinese astronomer Guo Shoujing (1231-1314) designed many outstanding instruments. We will look at some of the famous observatories in China and India.



[Dengfeng Observatory, designed by Guo Shoujing in 1276](#)



[Armillary spheres at the Purple Mountain Observatory in Nanjing designed by Guo Shoujing \(1231-1314\)](#)



We study the armillary spheres made by the Danish astronomer Tycho Brahe (1546-1601). (My second cousin lives in a castle built by a nephew of Tycho Brahe!) You will learn the difference between an ecliptic armillary sphere and an equatorial armillary sphere. I also have a separate page about ["Fake" Armillary Spheres.](#)

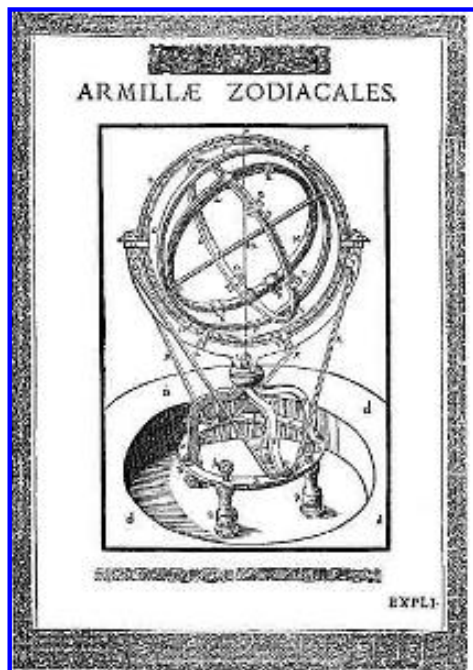

[Ecliptic armillary sphere](#)

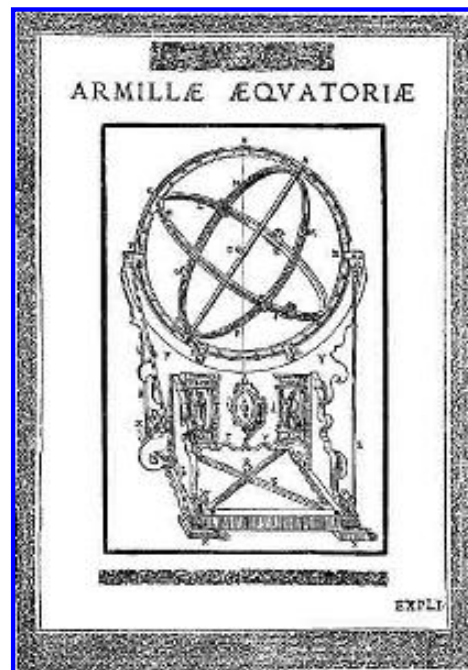

[Equatorial armillary sphere](#)

How were cathedrals used as solar observatories? We study meridian lines in European churches. I have created a separate page on meridian lines, [A Guide to "The Sun in the Church" by J.L. Heilbron](#).



[Meridian Line. S. Petronio, Bologna, Calter Photo](#)



[Solar eclipse at the Meridian line at S.Maria degli Angeli in Rome by Mario Catamo](#)

[The Ambassadors by Holbein](#) is a famous example of [Anamorphosis](#). Do you see the strange object on the floor? Close your left eye, put your face close to the computer screen near the right side of the picture. You will then see a skull! If you can't get it to work, you can cheat and look at a [picture](#) of it.

The reason why I include this painting on this page, is because it contains an incredible collection of astronomical and mathematical instruments! Please check out my page about [The Ambassadors by Holbein](#).



[The Ambassadors \(1533\), by Hans Holbein the Younger \(1497/8 - 1543\)](#)

Ancient Astronomical Instruments

- Undergraduate research project on [Calendars, Interpolation, Gnomons and Armillary Spheres in the Work of Guo Shoujing \(1231-1314\)](#) by my student Ng Say Tiong.
- [Medieval science & scientific instruments](#) by Richard A. Paselk, Department of Chemistry, Humboldt State University.
- [Astronomical Instruments](#).

Tycho Brahe (1546-1601)

- [Tycho Brahe - official website](#).
- [The astronomical instruments of Tycho Brahe](#).
- [Dansk Astronomi gennem 400 år](#), 400 years of Danish Astronomy (in Danish).
- [Brian Greig](#) is going to make models of Tycho's armillary spheres for me.



Sundials

- Undergraduate research project on [The Mathematics of Sundials](#) by my students Liew Huay Ling and Lim Siew Yee.
- [Sundials on the Internet](#).
- [North American Sundial Society](#).
- [The British Sundial Society](#).
- [Sundials on the Internet - Four simple sundial projects for you to make](#).
- [Sundials](#) by Jack Aubert.
- [Sundials](#) by Francois Blateyron.
- [Frans Maes' Homepage - Sundials \(English\)](#).
- [A Horizontal Sundial](#) by Robert C. Berrington.
- [Universal Pocket Sundial - Authentic reproduction of an antique portable sundial](#).
- [Queens' College Cambridge - Sundial](#).
- [sundial links](#) by Daniel Roth.
- [Polyhedral sundial](#).

Analemmatic Sundials

- [Of Analemmas, Mean Time, and the Analemmatic Sundial](#) by Frederick W. Sawyer III.
- [Make your own Sundial](#) from the Hartebeesthoek Radio Astronomy Observatory.
- [Equator projection sundials](#) by J.A.F. de Rijk. From the web pages of [fer j. de vries](#).
- [Analemmatic Sundials: How to build one and why they work](#) by C.J. Budd and C.J. Sangwin of the University of Bath.

Moondials

- [Make your own Moondial](#).

- [Moondials](#) from Gothic Gardening.

Nocturnals

- [Pocket Sundial, Star Clock, star time](#) by Keith Powell.
- [Shepherd's Watch](#) makes a nice nocturnal. They also make nice sundials, but notice that their Explorer model does not adjust for the season, only for the latitude.



Celestial globe made for the Beijing Observatory by Ferdinand Verbiest (1673)



[Celestial Star Globe](#)

Celestial Globes

- [Celestial Star Globe](#) from Hubbard Scott NTA.

Astrolabes

- astrolabes.org.

- [Keith's astrolabes: a Java program.](#)
- [Geoffrey Chaucer on the Astrolabe, in modern English](#) at [Anthony's Renaissance Faire Pages.](#)
- [A Treatise on the Astrolabe Geoffrey Chaucer, 1391.](#)
- [Clockworks: Astrolabe](#) from Britannica.com.
- [Astrolabes by Norman Greene.](#)
- [Martin Brunold - Astrolabienmacher](#)



[The large Samyat Yantra, equatorial sundial, at Jaipur](#)

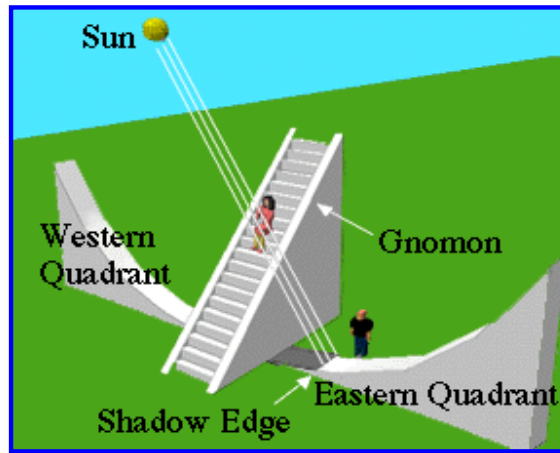

[Drawing of the small equatorial sundial showing the shadow, quadrants, gnomon, and Sun rays](#)

Jaipur Observatory

- [Jantar Mantar: The Astronomical Observatories of Jai Singh II](#) by Barry Perlus, Department of Art at Cornell University, is an absolutely stunning spherical VR imaging project.
- [Jaipur - Jantar Mantar.](#)
- [Jaipur Observatory.](#)
- [18th Century Observatories of Maharaja Sawai Jai Singh II](#) by C. Hartley, Director of the Ernest B. Wright Observatory at Hartwick College.

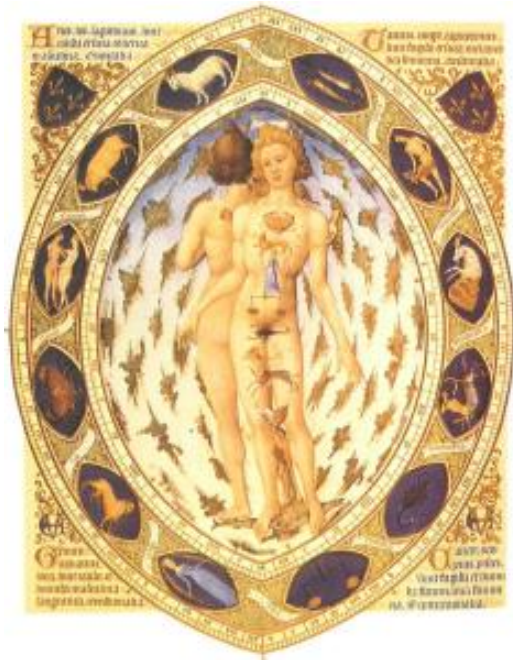

15th century French woodcut

Astrology

Does astrology make sense? I'm personally skeptical. In the past, however, there was a close relationship between astronomy and astrology, and astronomy has great historical interest. We look at the mathematical foundation of some of the key concepts in both Western and Chinese astrology.

What do astrologers mean when they say that somebody has an Aries ascendant? In order to understand this, we study the division of the ecliptic into houses. This is a very difficult issue, especially in high latitudes.



Astrology

- Undergraduate research project on [The Mathematics of Astrology: Does House Division Make Sense?](#) by my student Kevin Heng Ser Guan.
- [Skeptic's Dictionary astrology](#).
- [Astrology Overview](#) by Australian Skeptics.
- [SC/BC 1800C.03 - Analysis of Astrology FAQ Page](#) collected and edited by M.M. De Robertis (Instructor) at York University.
- [Studies on Astrology](#) from Skepsis, published by Norwegian Skeptics.
- [The Astrotest, A tough match for astrologers](#) by Rob Nanninga.
- [Skeptical Information Links: Astrology](#) by Jim Lippard.
- [Astrology & Science](#).



15th century Italian woodcut

Navigation

Why is it harder to find your position at sea than at land? We study how ancient sailors in different parts of the world navigated in different ways, and how technological advances opened up new possibilities for discoveries and trade.

Why is it harder to determine the longitude than the latitude? In 1714 the British Parliament offered 20,000 pound to anybody who could come up with a practical method to determine the longitude at sea. That was the equivalent of US\$12 million in modern money! The Astronomer Royal was only paid 100 pounds a year, and had to pay for his own instruments.



We will watch the movie [Longitude](#), starring Jeremy Irons, which is based on the best-selling book [Longitude: The True Story of a Lone Genius Who Solved the Greatest Scientific Problem of His Time](#) by Dava Sobel.

Why is it harder to find your position in an air plane than at sea? We look at some modern methods, including GPS. We will also have a mystery guest- lecturer.

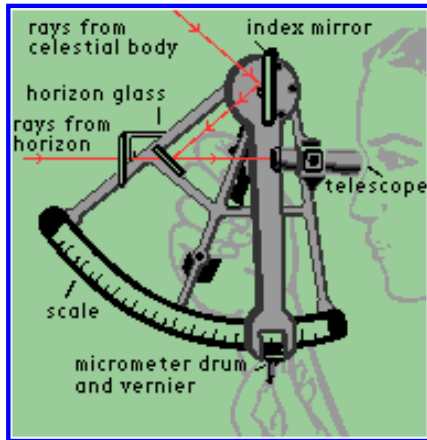

General Navigation

- An honours project on [The Mathematics of the Longitude](#) by my student Wong Lee Nah.
- Henning Umland has a wonderful [Short guide to celestial navigation](#).
- [Celestial Navigation Net](#) is one of my favorite sites. Very comprehensive!
- Celestial Navigation by Al Placette (<http://peck.ipph.purdue.edu/al/space.html>). (Broken link. Can anybody please help?)
- James R. Frysinger's course page on [Celestial Navigation](#) at the College of Charleston.



[Harrison's 4th Timekeeper and Longitude prize-winner](#)

Finding the Longitude

- [NOVA Online Lost at Sea The Search for Longitude](#).
- [John Harrison and the Longitude Problem](#) from The Royal Observatory Greenwich.

General History of Navigation

- [The Columbus Navigation Homepage](#) by Keith A. Pickering.
- [Determination of Latitude by Francis Drake on the Coast of California in 1579](#) by Bob Graham.
- [The Viking Sun Compass](#) by Franck Pettersen, Northern Lights Planetarium, Tromsø, Norway. From the [Planetarian](#).
- [The Mariners' Museum Age of Exploration](#).
- [Wayfinders: A Pacific Odyssey](#) on PBS.
- [StudyWorks! Online Navigation and Mapping](#).
- [Medieval and Twentieth Century Navigation](#) from the Columbus and America site at NASA.
- [John Charles Fremont](#) by Bob Graham.



Danish [high school](#) students working on a [navigation project](#)

On-line Navigation Tools

- [Bowditch -The American Practical Navigator](#).
- [JavaScript Navigator HomePage](#).
- [On Line Nautical Almanac](#) from [Navigator Light Software](#).



Mercator's 1569 world map

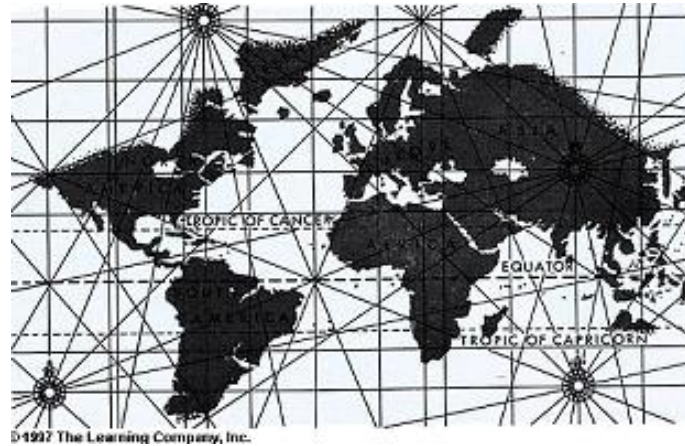

Mercator map of the world attributed to Edward Wright (1599)



Modern Mercator map

Cartography

Most capital cities have a geographical origin of coordinates, which is used when making maps for the country. All cities also have a zero point for road distances from the city center to other points. Why do capital cities need an origin of coordinates? In the past, finding coordinates, especially the longitude, was so hard that the best way was to pick a local origin, do astronomical observations at that point, and then do triangulation for the rest of the country. That's why the origin of coordinates is often at observatories.

In London the origin of coordinates is at Greenwich, while the zero point for road distances is at Trafalgar Square. In Oslo the origin of coordinates is at the Observatory, while the zero point for road distances is at Stortorvet. But what about Singapore? After a bit of detective work, and a lot of help from various people, I found that the origin of coordinates is at Empress Place and the zero point for road distances is at the old General Post Office, now the Fullerton Hotel. For more details, see my page on [Where is the Geographical Origin of Coordinates of Singapore?](#)

SECOND SCHEDULE
THE LAND SURVEYORS ACT
THE LAND SURVEYORS (CONDUCT OF TITLE SURVEYS) RULES 1991
(RULE 14)

ORIGIN OF CO-ORDINATES	ORIGIN OF MERIDIAN OF REFERENCE			CO-ORDINATES		TRIANGULATION SYSTEM	MAXIMUM ERROR
	NAME OF STATION	LATITUDE	LONGITUDE	MERIDIAN	PERPENDICULAR		
				METRES	METRES		
FLAG STAFF, HERBERT PLACE BUILDING SINGAPORE	FLAG STAFF, HERBERT PLACE BUILDING	1°17'15".08 N	103°51'10".78 E	30,000	30,000	ASA	+1"

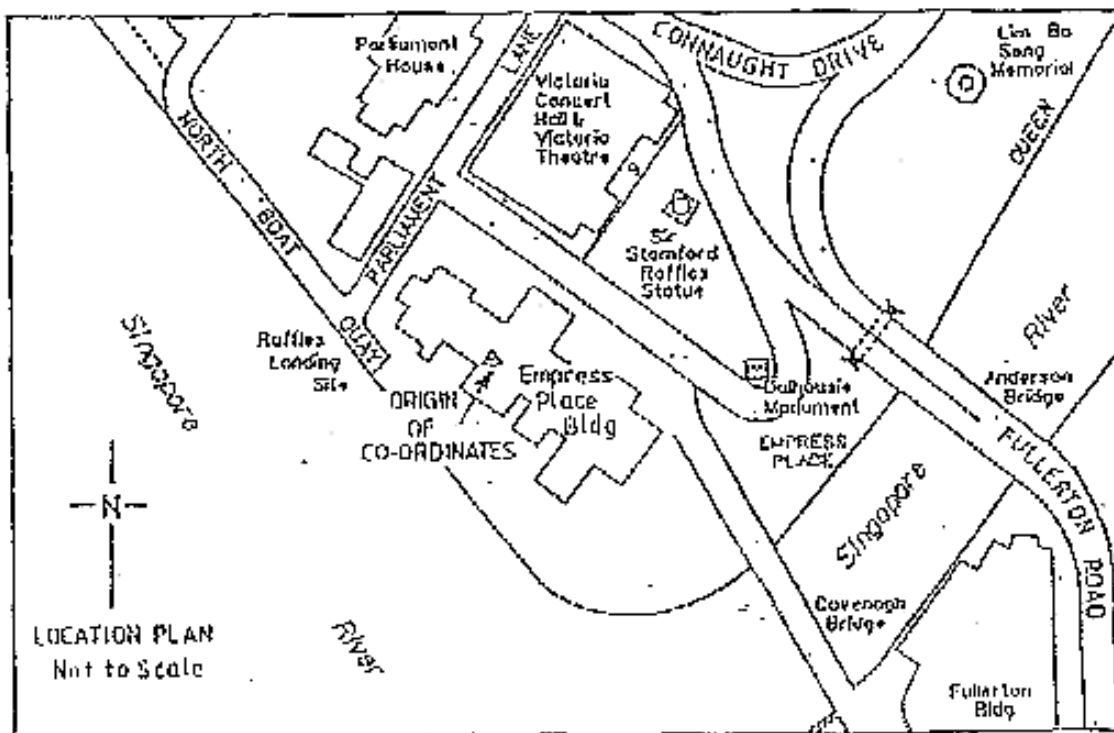

How big is the Earth? We look at Eratosthenes's solution to this problem.

Did people in the Middle Ages believe that the Earth was flat?

Why is there no perfect map? We define the curvature of a surface and show that the curvature of the Earth is positive while the curvature of the plane is zero.

What makes the Mercator projection so important in navigation? We study the geometry of rhumb lines. We also show how it is related to the invention of logarithms.

Cartography

- [Cynthia Lanisus' Lessons: The Mathematics of Cartography](#) from Rice University.
- [Map Projection Home Page](#) from the Geography Department, Hunter College, City University of New York.
- [The Mercator Projection](#) by Bernard S. Greenberg.
- [Introductory Mapping Courses](#) and [Instructional Modules](#) at the [Virtual Geography Department](#).
- [Map Projection Overview](#) by Peter H. Dana, Department of Geography, University of Colorado, Boulder.
- [Mathematical Cartography](#) by Hans Havlicek, Abteilung für Lineare Geometrie, Technische Universität Wien.

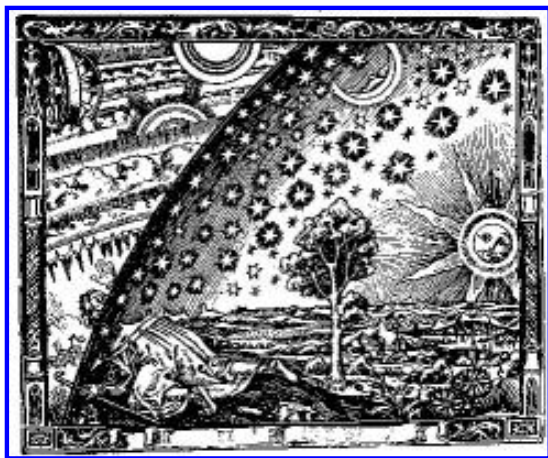

[This is NOT a medieval woodcut!](#)

The Flat Earth Myth

- [This is NOT a medieval woodcut!](#) by Kerry Magruder.
- [The Myth of the Flat Earth](#) by Jeffrey Burton Russell.



[Newgrange](#)

Archaeoastronomy

Was Stonehenge an observatory? When were the pyramids of Egypt built? Archaeoastronomy is a very active area these days. Many ancient monuments reveal an astronomical background.



Stonehenge

- [Stonehenge and Astronomy.](#)
- [EARTH MYSTERIES Stonehenge.](#)
- [Build Your Own Stonehenge!](#) from familyeducation.com

- [Stonehenge](#) on the Discovery Channel.
- [Stonehenge](#) by Emily Mace.
- [Science and Stonehenge](#) from English Heritage.



[Winter Solstice Sunrise at Newgrange](#)



[Winter Solstice Sunrise at Maeshowe](#)

Newgrange and Maeshowe

- [Newgrange Megalithic Passage Tomb - Ireland](#) has a great animation showing how the passageway is illuminated by the sunrise at the Winter solstice.
- Winter Solstice at Newgrange (<http://members.theglobe.com/newgrange2/solstice.html>). (Broken link. Can anybody please help?)
- [Geniet Heaven and earth](#) contains both [Geniet: Newgrange](#) and [Geniet Research on Maes Howe, Orkney, UK](#).
- [Maeshowe and the Winter Solstice](#).



Pyramids

General Archaeoastronomy

- [The Center for Archaeoastronomy](#) at the University of Maryland.



[Astronomical instruments in the Imperial Observatory in Beijing made by the Jesuit missionary Ferdinand Verbiest, 1670](#)

Cultural Astronomy



[The Singapore Flag](#)



[The Singapore Coat of Arms](#)

What is “wrong” with the Singapore flag? Why is the coat of arms more correct? I have a page on [The Mathematics and Astronomy of the Singapore Flag](#).

What is a Harvest Moon? What is a Blue Moon? What is Groundhog Day? There are a lot astronomical terms that people use but don't really understand.

What was the Star of Bethlehem? How can eclipses be used to date historical events?

Chaucer wrote a book on the astrolabe, and the Canterbury Tales are filled with astronomical references.

[Celestial Navigation Net](#) has a very interesting section on Dante and Celestial Navigation!



What is a Blue Moon?

- [What's a Blue Moon?](#) by Donald W. Olson, Richard Tresch Fienberg, and Roger W. Sinnott. The definite article from [Sky & Telescope](#) magazine. [Sky & Telescope](#) no longer has a free archive, but you can [buy](#) the article or look it up in a library.
- You can also search for the earlier articles “Once in a Blue Moon” by Philip Hiscock and “Blue-Moon Mystery Solved?” by Donald W. Olson and Roger W. Sinnott from [Sky & Telescope](#).

What is a Harvest Moon?

- [Watch Out for the Harvest Moon](#) from SpaceScience.com.
- [The Harvest Moon](#) by Larry Gedney. From Alaska Science Forum.

The Star of Bethlehem

- [The Star of Bethlehem](#) from the [Astronomical Applications Department of the U.S. Naval Observatory](#).
- [The “Stars” of Bethlehem](#) by Jeff Kanipe from the radio show [Earth & Sky](#).
- [Star of Bethlehem](#), provided as a service by the Griffith Observatory.
- [Common Errors in “Star of Bethlehem” Planetarium Shows](#) by John Mosley, Program Supervisor, Griffith Observatory. From the [Planetarian](#).
- [Yet Another Eclipse for Herod](#) by John P. Pratt. From the [Planetarian](#).
- [The Bimillenary of Christ's Birth: The Astronomical Evidence](#) by William P. Bidelman, Warner and Swasey Observatory, Case Western Reserve University. From the [Planetarian](#).

Dating the Crucifixion

- [Problems in Dating the Crucifixion](#) from the [Astronomical Applications Department of the U.S. Naval Observatory](#).



[Phil the groundhog](#)

Groundhog Day

- [Groundhog Day and Chinese Astronomy](#) by Kelley L. Ross.
- [Groundhog Day History](#) from Stormfax.
- [More Information on Groundhog Day](#) from the radio show [Earth & Sky](#).
- [Groundhog.org - the Official Site of the Punxsutawney Groundhog Club](#).



Astronomy in Nature

I have a separate page on [What Does the Waxing or Waning Moon Look Like in Different Parts of the World?](#) This is a complex question that confuses many people.

What does the orbit of the Moon around the Sun look like? Most people, even almost all mathematicians I've asked this question, tend to believe that it will have loops and look something like the picture below.

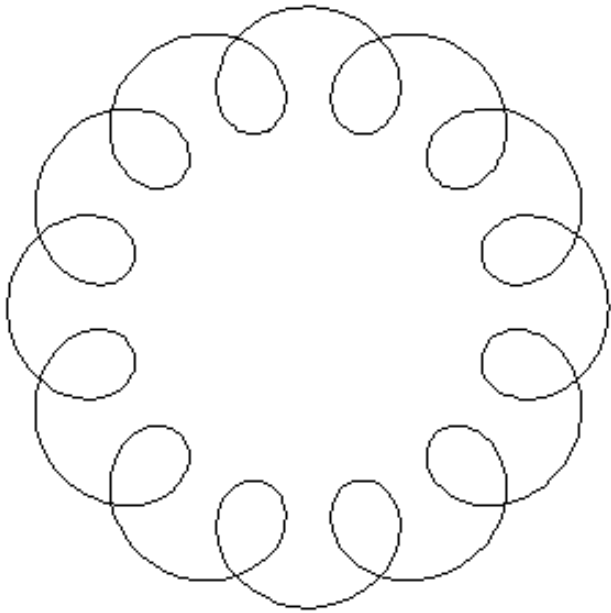

In fact it looks like this picture!

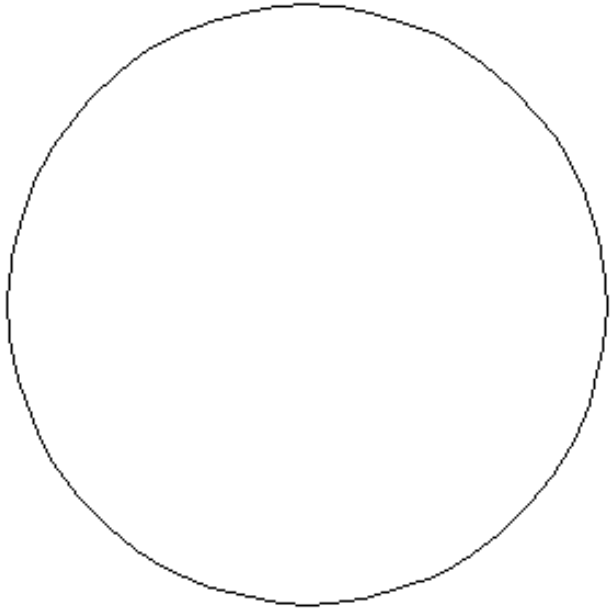

It is not a circle, but is close to a 13-gon with rounded corners. It is locally convex in the sense that it has no loops and the curvature never changes sign. The reason why we get a 13-gon is because there are about 13.4 sidereal months in a tropical year. I have a page that explains why [The Orbit of the Moon around](#)

[the Sun is Convex!](#)

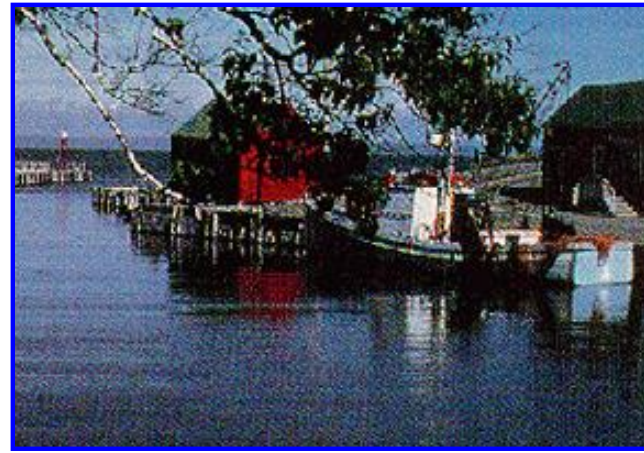

[Halls Harbour, Nova Scotia, six hours apart](#)

[Why are there two high tides each day?](#) This is very frequently asked question! I used to think that the answer was simple, but after looking around in the library and on the web, I discovered several different attempts at explaining it. Newton's equilibrium theory from 1687 used the differential of the gravitational force, but some people (especially oceanographers) also consider a centrifugal force caused by the rotation of the Earth around the Earth-Moon barycenter. Unfortunately, it seems to me that the methods using a centrifugal force are unnecessarily complicated, if not outright wrong! I will describe some of the attempted [explanations](#) I found.

How often can we see lunar and solar eclipses in Singapore? It turns out that it is fairly easy to make reasonably accurate eclipse predictions. There are several solar eclipses each year, but at a given place, they occur on average only every 360 years. [Solar eclipses, Singapore](#) lists all solar eclipses visible from Singapore between 1700 and 2100. The last total eclipse was in 1821, and there will be annular eclipses in 2019 and 2053, but I'm afraid there will not be any total eclipses in Singapore before 2100.

How is astronomy related to the ice ages? It turns out that changes in the Earth's movement is related to the ice ages.

Why does the Moon look bigger when it is near the horizon?

Can you balance an egg on the Spring equinox? This turns out to be related to the [Chinese calendar](#)!



Eclipses

- [Professor Parkinson's Eclipse Website](#). I went with him to Sabah in October 1995 to watch a total solar eclipse.
- [References on Eclipses](#) from the [Astronomical Applications Department of the U.S. Naval Observatory](#).
- [Solar eclipses, Singapore](#) lists all solar eclipses visible from Singapore between 1700 and 2100.
- [There Goes the Sun](#) from [Thursday's Classroom](#) at [SpaceScience.com](#) at NASA.

Astronomy and Climate

- [The Seasons and the Earth's Orbit - Milankovitch Cycles](#) from the [Astronomical Applications Department of the U.S. Naval Observatory](#).



[What's Wrong With This Moon?](#)

The Moon

- [What's Wrong With This Moon?](#) by Jim Loy.
- [The Moon](#) by Jim Loy.
- [Southern Hemisphere Moon Phases](#) by Deborah Byrd from the radio show [Earth & Sky](#).

Phases of the Moon

- [Virtual Reality Moon Phase Pictures.](#)
- [Phases of the Moon.](#)
- [Lunar Outreach Services.](#)

The Moon Illusion

- [Solstice Moon](#) from [Thursday's Classroom](#) at [SpaceScience.com](#) at NASA.
- [Explaining the moon illusion](#) by Lloyd Kaufman, and James H. Kaufman.
- [New Thoughts on Understanding the Moon Illusion](#) by Carl J. Wenning, Physics Department, Illinois State University. From the [Planetarian](#).
- [The Moon Illusion, Part 2](#) by Lee Dye from ABCNEWS.com.

Balancing Eggs on the Spring Equinox

- [Standing an egg on end on the Spring Equinox](#) from Phil Plait's Bad Astronomy site. This is related to the [Chinese calendar](#)!

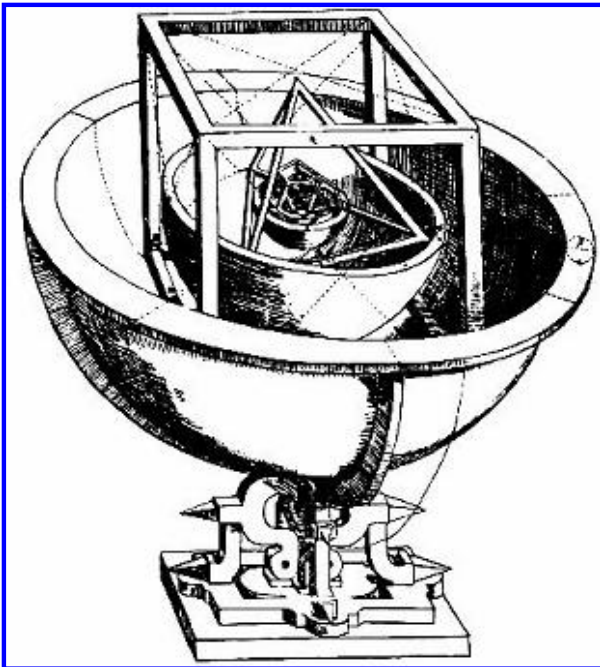

Kepler's Mysterium Cosmographicum, 1596

Lecture Notes

I have left a slightly edited version of the first chapter of Strobel's note at the LT 27 Co-op together with my lecture notes on [The Mathematics of the Public Holidays of Singapore](#). I will try to write some brief notes continuously, which I will post here.

- Positional astronomy [12pt/20 pt](#).
- Celestial navigation [12pt/20 pt](#).

Tutorials and Homework Assignments

Homework

- [Homework 1](#)
- [Homework 2](#)

Tutorials

- [Tutorial 1](#)
- [Tutorial 2](#)
- [Tutorial 3](#)
- [Tutorial 4](#)
- [Tutorial 5](#)
- [Tutorial 6](#)
- [Tutorial 7](#)
- [Tutorial 8](#)
- [Tutorial 9](#)
- [Tutorial 10](#)
- [Tutorial 11](#)

Old Exams

- [Exam 2001/02 Semester 1 Solutions](#)
- [Exam 2002/03 Semester 1 Solutions](#)
- [Exam 2003/04 Semester 1 Solutions](#)

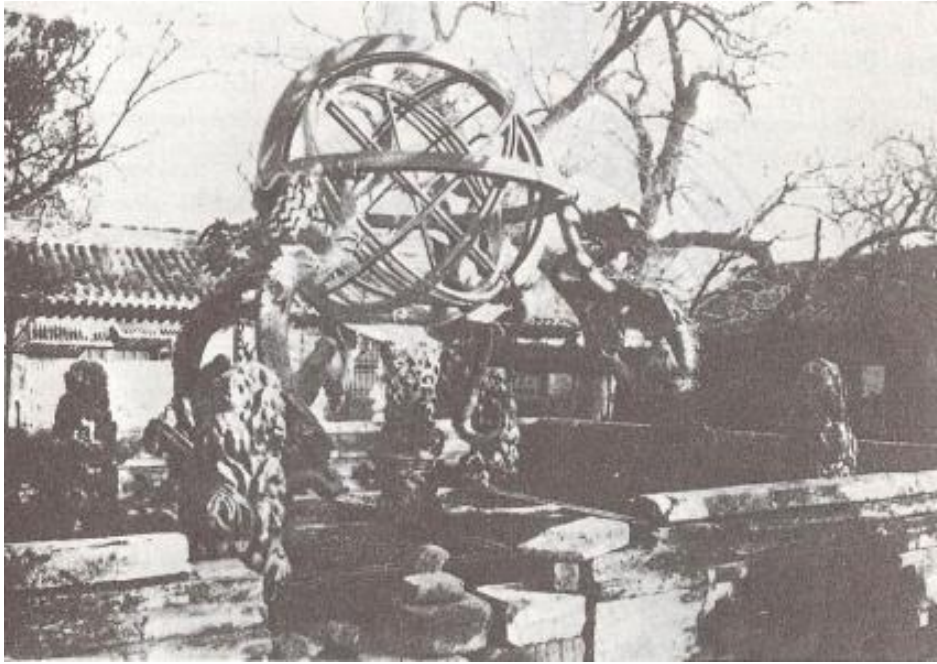

Armillary sphere at the Purple Mountain Observatory in Nanjing designed by Guo Shoujing (1231-1314)

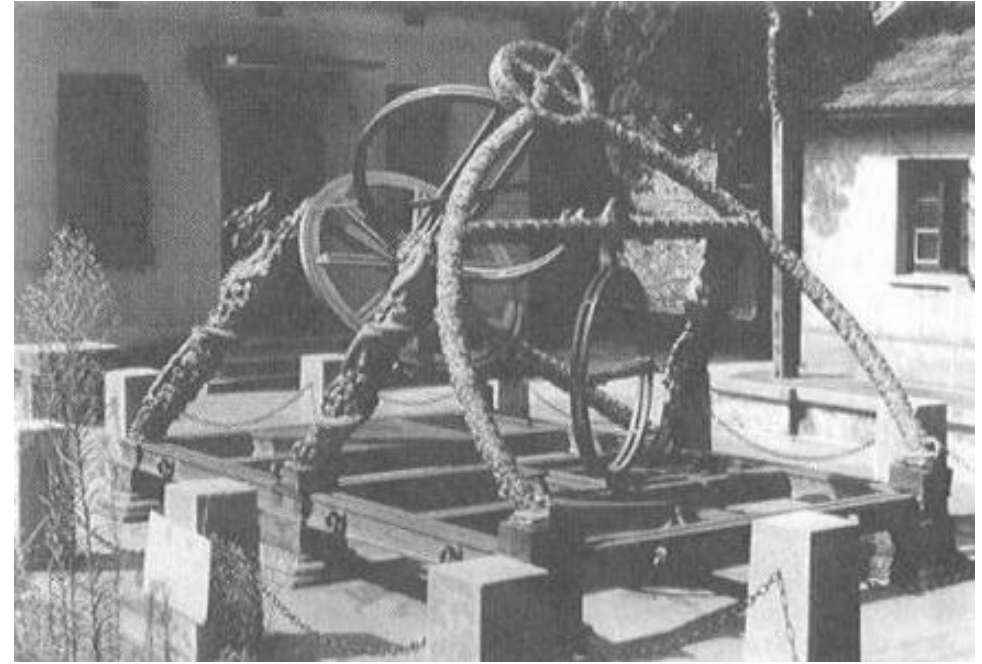

Armillary sphere at the Purple Mountain Observatory in Nanjing designed by Guo Shoujing (1231-1314)

Past Homework

I have a separate page for [past homework](#).

Past Projects

I have a separate page for [past projects](#).

Project Topics

All the topics we talk about in lecture can be extended to projects. Here are some suggestions. I also encourage you to propose your own topics and send them to me for approval.

- [Astronomy and its History](#)
 - The appearance of the Moon at different latitudes.
 - The heliocentric system versus the geocentric system.

- The works of Galileo.
- The works of Ptolemy.
- The works of Copernicus.
- The works of Brahe.
- The works of Kepler.
- Spherical trigonometry in astronomy.
- Muslim prayer times at high latitudes.
- Qibla, the direction to Mecca.
- The journeys of Columbus
- Lectures notes to describe the physical demonstrations in the class.
- [Calendars](#)
 - Chinese Festivals.
 - The meaning of the names of the 24 jie qi in the Chinese calendar.
 - Prediction and observation in the Islamic calendar.
 - Muslim prayer times at high latitudes.
 - Indian calendars.
 - History of the computation of Easter.
 - The Gregorian calendar reform.
 - The Jewish calendar.
 - The Mayan calendar.
 - Leap seconds.
- [The Equation of Time](#)
 - Sunrise and Sunset times in the tropics.
- [Ancient Astronomical Instruments](#)
 - History of the astrolabe.
 - Sundials.
 - Armillary spheres.
 - Cathedrals as solar observatories.
- [Astrology](#)
 - House division in Astrology.
 - Astronomy and astrology in the works of Chaucer.
 - Astronomy and astrology in the works of Dante.
 - The star of Bethlehem.
 - The eight characters in Chinese astrology.

I have received some excellent astrology related projects, but many of the astrology projects I get are not very interesting. I'm not particularly interested in reading about the character traits that astrologers claim that Aries people have. I'm more interested in things like why astrologers claim that Aries people have these traits.

- [Navigation](#)
 - Development of navigational instruments.
 - Celestial navigation.
 - History of navigation.

- Finding the longitude.
- Columbus as a navigator.
- The Viking sun compass.
- Navigation in the Singapore Navy and Air Force.
- GPS.
- The impact of developments in navigational technology on history, economics and geography.
- A mathematical supplement to the movie [Longitude](#).
- [Cartography](#)
 - Map projections.
 - The Mercator projection and the invention of logarithms.
 - Why is Empress Place the zero point of Singapore?
- [Archaeoastronomy](#)
 - Was Stonehenge an observatory?
 - Astronomical alignments in the Egyptian pyramids.
- [Cultural Astronomy](#)
 - Astronomy and astrology in the works of Chaucer.
 - Astronomy and astrology in the works of Dante.
 - The star of Bethlehem.
 - Cathedrals as solar observatories.
 - Muslim prayer times at high latitudes.
 - Qibla, the direction to Mecca.
 - What is a Harvest Moon?
 - What is a Blue Moon?
 - Ancient Chinese eclipse predictions.
 - Using eclipses to date historical events.
- [Astronomy in Nature](#)
 - The appearance of the Moon at different latitudes.
 - How is astronomy related to the ice ages?
 - Predicting tides.
 - Predicting eclipses.

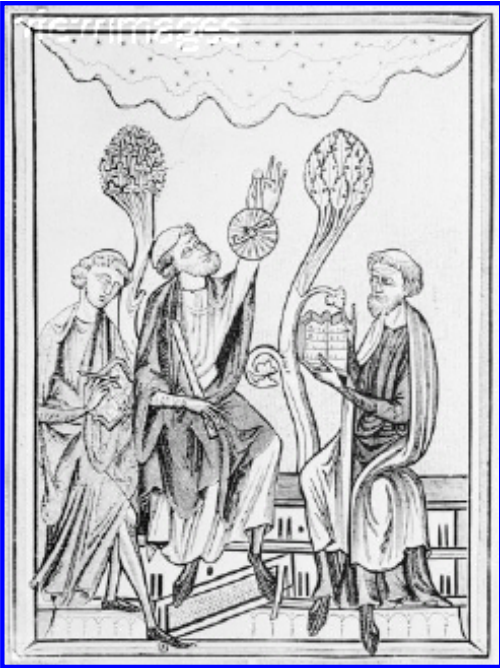

References

I have a separate web page with [references](#).



[Adam Schall \(1591-1666\), Imperial Astronomer in Beijing](#)



Armillary sphere

Good-bye!

Congratulations! You've made it to the end of my page! Thanks for your patience! But before you go, it's time for a little quiz. In the picture of Adam Schall above, can you name the five astronomical and three geometrical instruments in the picture? Can you tell what is wrong with one of them? Hint: Look at the picture on the right. I have included [answers](#).

I hope you have found something of interest. That makes my efforts worthwhile. Feel free to send me a [message](#).

And remember, if life is hard, do like the sundial: Count only the bright hours!

[Helmer Aslaksen](#)

[Department of Mathematics](#)

[National University of Singapore](#)

aslaksen@math.nus.edu.sg

[Web Server Statistics for Helmer Aslaksen](#), produced by [Analog](#).



I use the [W3C Markup Validation Service](#) and the [W3C Link Checker](#).

ABORIGINAL STAR KNOWLEDGE

Native American Astronomy



[Jump to Page Buttons](#)



[San Francisco Exploratorium 10 Coolest Sites for July, 1996.](#)
Astronomy got special mention. The whole [Exploratorium](#) is cool for neat interactive science exhibits anytime



[MIT Astronomy Education resources Native Astronomy, Site of the Day 9/1/96](#)

Hi
Support this important site today!

[Click to Give](#)
fully refundable

amazon honor system
[Learn more.](#)

[Shop at our online poster store!](#) We have selected a great group of posters with images from the Hubble Space telescope, Deep Sky images, the Earth from Space, the Solar System, and Men in Space. Take a look and decorate your room, or find a great gift here.



ABORIGINAL STAR KNOWLEDGE MENU



*If you get lost -- or return in other sessions --
at the bottom of each page is a button to return to this menu.*



Astronomy Magazine Almanac: Current month night sky-- constellations at early evening. Good moon phases diagram if you click on Sky Events at the bottom of the almanac page.



Lakota Stellar Theology: "As above, so below" spiritual philosophy that unifies Lakota star knowledge -- a book that puts together star knowledge gathered from elders over many years. You can get from Sinte Gleshka Rosebud Reservation Lakota University



Lakota sacred star map, and Earth mirror sacred map in Black Hills of star-timed ceremonial round



Arvol Looking Horse Announces Worldwide June 21 Prayer Ceremony, date based on Star Knowledge



Equinoxes, solstices , ecliptic plane for sunpath among the stars during the solar year. Constellations. The 26,000 year precessional cycle of the stars



Sun's seasonal path among the stars what it means for Lakota elders to say sun is "in" a constellation; what is special about constellations of the Zodiac. Starmaps



Lakota winter solstice: all the sacred constellations are at the zenith of the sky. Large starmap suitable to print for class handout.



Bighorn Medicine Wheel: stone, sun, stars on a mountaintop, early Sun Dance instructions, best-known Wheel, on Medicine Mountain



Up on Medicine Mountain with Dr. John Eddy, June 21, 1972: Sunrise lineup with Bighorn Wheel stone observatory cairns



How Medicine Wheel works. Lots of other wheels. Stone Medicine Wheels began 2,200 years ago on the northern plains of Alberta and Saskatchewan

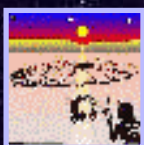

Ancient Geology of Medicine Mountain: Roots of the Continent, rock folds of all eras from the first to now, climbing to the peak: backward in time.



1st Magnitude Stars Table in order of brightness, with conventional and Lakota names, constellation locations, and northern visibilities.



Star knowledge study with naked eye; simple skywatch party, learning the sky, using hands as measuring instruments



Books on-line (and reviews) on Native Star Knowledge. On-line Bookstore selects for credit-card cording from Anazon.com.



Teaching and learning resources on internet, in catalogs, books for the beginning hobbyist or teacher.

-
- **Stone Medicine Wheels Bibliography**
 - **AMERICAN INDIAN ASTRONOMY TEACHER GUIDE, TEACHER INFORMATION, STUDENT ACTIVITIES**, (Middle School, grade 5, see book review); By Priscilla Buffalohead illustrated by Robert DesJarlait -- covers lightly for elementary level ideas treated in more depth here for older students and teacher science background
 - **Crab Nebula Supernova, 1054** was visible in the daytime for 20 days. It was recorded by Natives in Chaco Canyon and elsewhere. Check out the rest of this Anasazi site.
 - **Von Del Chamberlain** one of the early discoverers of many Crab Nebula supernova petroglyphs, says too many people are now saying every petroglyph is astronomical -- thus discrediting the ones that really are

BRIEF PERCEPTIONS of Astronomical Phenomena, Menominee, recorded by Colleen Waukachon:

- [The Moon](#) --
- [Aurora Borealis](#) -- In Anishnaabemowin, this is *jibayag niimi'idiwag*, Ghosts Are Dancing, *jibay* is ghost of a dead person
- [Meteors](#) -- finding little star-marked stones.
- [Meteors and Native Americans](#) -- as an astronomy guy researched and presents this.
- [Center for Archaeoastronomy](#) explains what it is, has some very short editorials and articles from back issues of its bulletin. Perhaps there will be more content to the website later
 - [Ethno-archaeoastronomy](#) brief article by Claire Ferrer about difficulties of collecting star knowledge from Mescalero Apache -- only a couple of old men knew it, and they were religiously forbidden to speak of it to women.
- [History of Astronomy](#) including ethnic and archaeoastronomy, web site mostly for astronomers, Max Planck Institute, Germany.



CREDITS: I drew the Lakota-style quilt sun-star in FreeHand and converted it to raster for these pages -- but to get it right, I had to look at the star on my actual quilt (by Elaine Brave Bull, Hunkpapa Lakota from Standing rock rez). The 3 natives marvelling at the moon -- some kind of eclipse -- was drawn by John Fadden (Mohawk artist) in 1970 or so, to illustrate a book of traditional stories by his father, elder Ray Fadden (Tehanatorens), several of which are star legends. It was then published in Akwesasne Notes. I scanned and traced it in FreeHand, to use with Heart of the Earth AIM Survival School Indian-centered science material prepared in 1993.

Navigation Buttons



Awards given to this Aboriginal Astronomy section

Page prepared by Paula Giese , text and graphics c. 1995, 1996, 1997

Last updated: 16/4/97

African Starlore

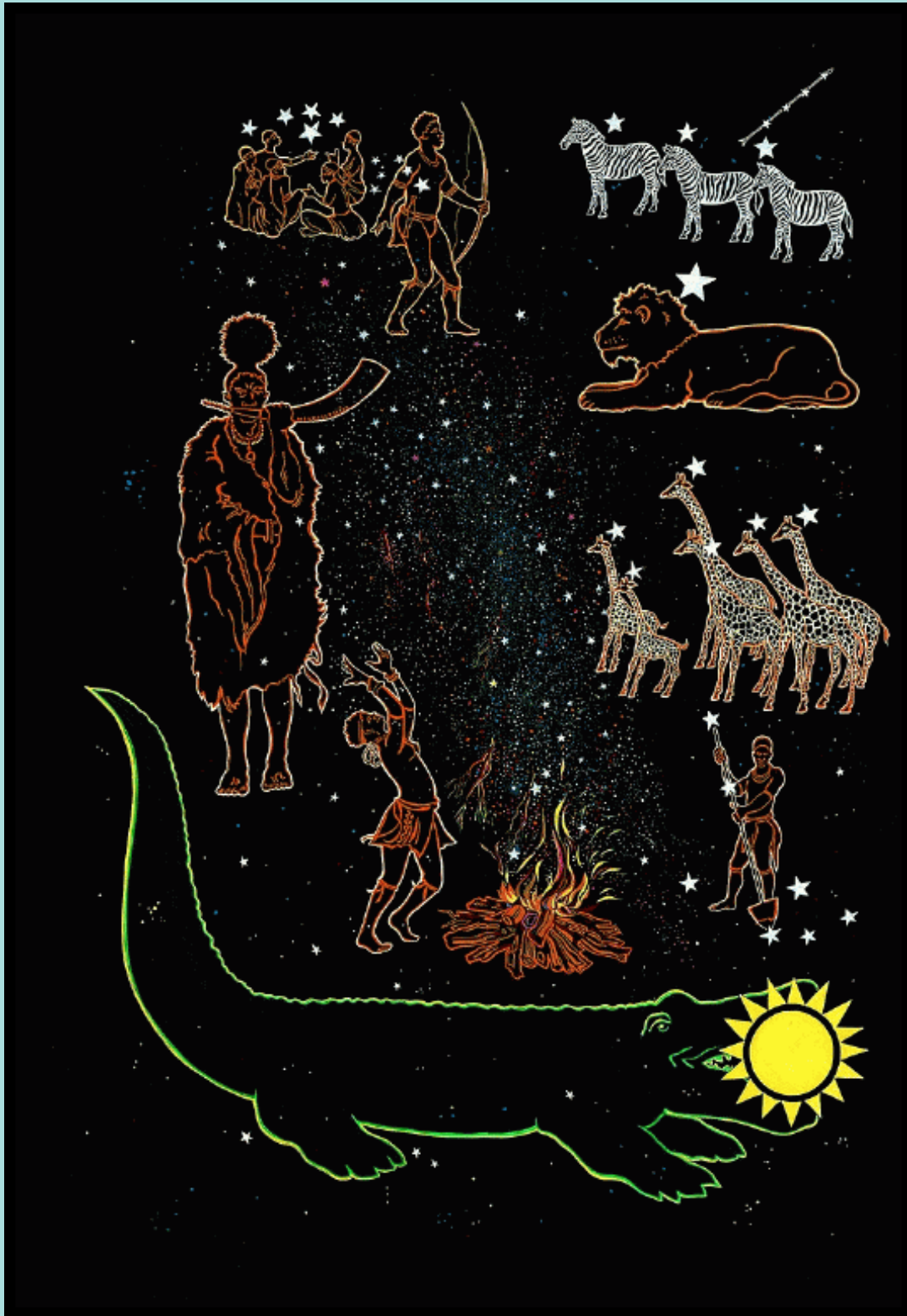

A poster was produced as part of the "Friends with the Universe" project which formed part of South Africa's first year of Science and Technology, YEAST, in 1998. The Starlore poster was the first in a series of ten which were distributed nationally. The aim of Friends was to use astronomy as a vehicle to promote science amongst the diverse communities in South Africa.

The [motif of the poster](#) (280kB) which is reproduced above comprises various scenes depicting legends of southern Africa that relate to the heavens. It was created by Braam Botha, and the copyright rests with SAAO. A small collection of legends assembled from many sources by [Dr Dave Laney](#) of SAAO is included below. Scenes from the poster image are juxtaposed with the relevant legend. Click on a part of the image to go straight to the legend.

Legends of the Khoikhoi and the San

- A girl child of the old people had magical powers so strong that when she looked at a group of fierce lions, they were immediately turned to stars. The largest are now in Orion's belt.



A strong-willed girl became so angry when her mother would not give her any of a delicious roasted root that she grabbed the roasting roots from the fire and threw the roots and ashes into the sky, where the red and white roots now glow as red and white stars, and the ashes are the Milky Way. *Dornan. The Bushmen (1925).*

And there the road is to this day. Some people call it the Milky Way; some call it the Stars' Road, but no matter what you call it, it is the path made by a young girl many, many years ago, who threw the bright sparks of her fire high up into the sky to make a road in the darkness. *Leslau, Charlotte and Wolf. African Folk Tales (1963).*

- When the Pleiades appear in the east, little ones are lifted by their mothers and presented to the stars . . . The Pleiades are considered friendly and the children are taught to stretch their hands toward them.
- The Pleiades, named *Khuseti* or *Khunuseh* by the Khoikhoi, are called the rainstars. Their appearance indicates the rainy season is near and thus the beginning of a new year. *Hahn. The Khoikhoi, or Bushmen (1881).*
- . . . when rain is accompanied by lightning, girls who are out in the open become killed by the lightning and are converted into stars. Therefore young unmarried women and girls must hide themselves from the rain. *Schapera (1930).*

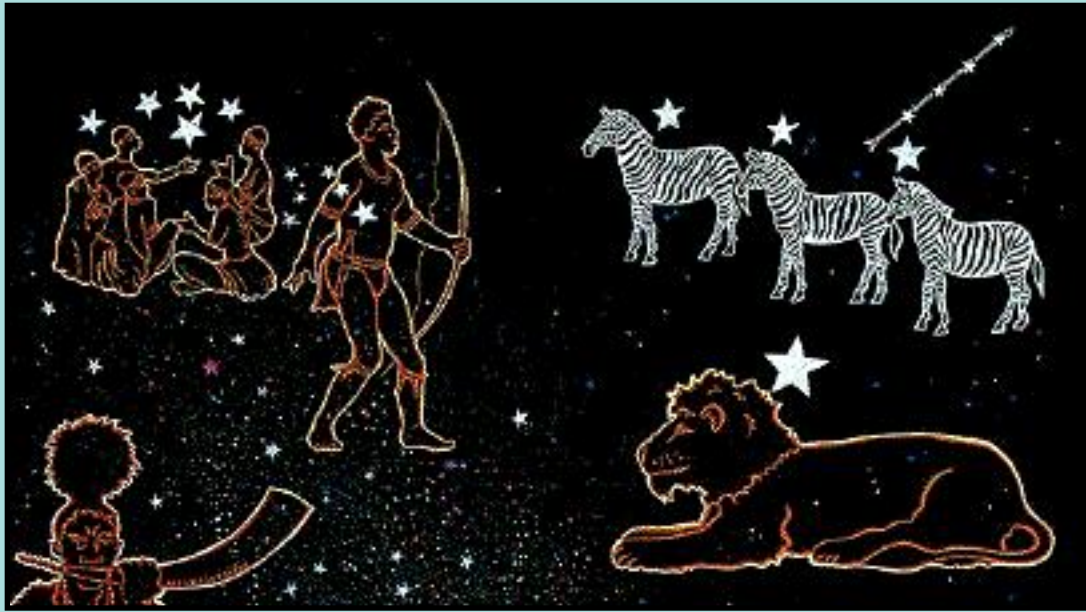

According to the Namaquas, the Pleiades were the daughters of the sky god. When their husband (Aldebaran) shot his arrow (Orion's sword) at three zebras (Orion's belt), it fell short. He dared not return home because he had killed no game, and he dared not retrieve his arrow because of the fierce lion (Betelgeuse) which sat watching the zebras. There he sits still, shivering in the cold night and suffering thirst and hunger.

- Initiated men among the Namaqua could not partake of hare's flesh. Long ago the moon sent a message to men that as it died and was renewed, so should men be. The hare told men instead they would die and perish like the hare, but said nothing of renewal. *Tooke. The Hottentots (1888)*.
- The Sun was once a man who made it day when he raised his arms, for a powerful light shone from his armpits. But as he grew old and slept too long, the people grew cold. Children crept up on him, and threw him into the sky, where he became round and has stayed warm and bright ever since.

The Sotho calendar

Canopus was called *Naka*(the horn), or *E a dishwa* (it is carefully watched). Sotho men would camp in the mountains, where they made fires and watched the early morning skies in the South. It was believed that the first person to see the star would be very prosperous that year, with a rich



harvest and good luck to the end of his life. In olden times the chief would give the lucky man a heifer. The day after Naka was sighted was the time for the men with divining bones to examine their bones in still water, to predict the tribe's luck for the coming year. Among the Venda, the first person to see *Nanga* (Canopus) in the morning sky announced his discovery by climbing a hill and blowing a sable antelope horn (*phalaphala*). Among the Mapeli, the first person to see the star would begin ululating loudly enough to be heard in the next village, which would then join the noisemaking to warn other villages, each in turn until all knew Canopus had been seen.

- When *selomela* (the Pleiades) rose in the east, frost was at hand and the leaves fell from the trees in the river beds.
- If the *senakane* (the little horn) (Achernar) when rising in the East is very bright and giving off little lightnings, and the bullrushes are still in flower, men fear an early frost. If Canopus is seen in May with a very intense light, the frost would be very hard.
- The shield of the little horn is the Small Magellanic Cloud, known as *mo'hora le tlala*, 'plenty and famine'. If dry dusty air made it appear dim, famine was to be expected.



The bright stars of the pointers and the southern cross were often seen as giraffes, though different tribes had different ideas about which were male and which were female. Among the Venda the giraffes were known as *Thutlwa*, 'rising above the trees', and in October the giraffes would indeed skim above the trees on the evening horizon, reminding people to finish planting.

Tswana

- The sky is stone, and the earth is flat. Water is beneath the earth and above the sky.
- The waning moon spills diseases.
- Its markings are a woman carrying a child, who was caught gathering wood when she should have been at a sacred festival.
- For the Tswana, the stars of Orion's sword were *`dintsa le Dikolobe'*, three dogs chasing the three pigs of Orion's belt. Warthogs have their litters while Orion is prominent in the sky --- frequently litters of three.



Some believed that after sunset the sun traveled back to the east over the top of the sky, and that the stars are small holes which let the light through. Others said that the sun is eaten each night by a crocodile, and that it emerges from the crocodile each morning.

- *Ntshune* was a star (possibly Fomalhaut) visible on winter mornings. This *`kiss me'* star showed the time for lovers to part before parents found them.
- The small constellation of Delphinus may have been seen by the Tswana as a mopane worm.

Sotho, Swazi, Nguni

- The sun's *`summer house'* and *`winter house'* (the solstices) were important to the traditional calendar as in many other parts of the world. To the Xhosa these were *`injikolanga'*, *`the turning back of the sun'*. As late as 1921, governors of royal Swazi villages trusted traditional observations more than printed calendars.
- Venus: *iCelankobe* (Zulu) = *`asking for mealies'*. As with the Sotho *Se-falabogogo* (*`crust scrapings'*), the idea is that someone who arrives for supper by the light of the evening star will do

rather badly. The Tswana believed that if Venus were in the evening sky at hoeing season, there would be a good harvest.

- According to Credo Mutwa, the Southern Cross is the Tree of Life, 'our holiest constellation'.



isiLimela or the Pleiades were the 'digging stars', whose appearance in southern Africa warned of the coming need to begin hoeing the ground. All over Africa, these stars were used as a marker of the growing season. 'And we say *isiLimela* is renewed, and the year is renewed, and so we begin to dig'. (Callaway 1970). Xhosa men counted their years of manhood from the time in June when *isiLimela* first became visible.

- To Xhosas, the Milky Way seemed like the raised bristles on the back of an angry dog. Sotho and Tswana saw it as *Molalatladi*, the place where lightning rests. It also kept the sky from collapsing, and showed the movement of time. Some said it turned the Sun to the east.
- For Swazi and Zulu skywatchers, *iNqonqoli* or *Ingongoni* was a star associated with wildebeest, whose calves were born in the season when Spica rose before the sun and the morning star.
- Canopus was known to some tribes as the 'ants' egg star' because of its prominence during the season when the eggs were abundant.

Assorted

- Among the Baronga each moon is regarded as a new birth after the death of the old one. At the appearance of the new moon, recently born children (third month) are 'shown their moon'. The mother flings a burning stick toward the moon as the grandmother tosses the child in the air, crying 'This is your moon'. The baby is then made to roll over in the ashes. Children lacking this rite would grow up stupid, and dull children are told, 'You have not been shown your moon'.

More Moon Legends

- See Hare and the Moon above under Khoisan stories, and the Moon and stupidity in the above paragraph.
- *Nwedzana*=waxing crescent. If the horns point up when the new crescent is sighted in the evening sky, it 'was said to be holding up all kinds of disease, and when the horns were tipped down, the moon was a basin pouring illness over the world.' (Sotho, Tswana, Venda)
- 'No doubt Shaka's harem guards were called the *Qwayi-Nyanga*, or moon-gazers, because they were to watch over the royal women as intently as the Zulu people watched the moon.'
Ng'olumhlope namhla (Zulu) was the black or dark day after the waning crescent's disappearance

from the sky. Many considered this a solemn day of rest, when no work or business should take place, and no weddings should be celebrated.

- `In Malawi the morning star is *Chechichani*, a poor housekeeper who allows her husband the moon to go hungry and starve; *Puikani*, the evening star, is a fine wife who feeds the moon thus bringing him back to life.'
- On March 30, 1885 an Ndebele impi which had just set out on campaign saw the moon turn red in a total eclipse, decided the army had been bewitched, and returned to Bulawayo.
- Many Africans saw the markings on the moon as a man or woman carrying a bundle of sticks.
- For the Khoikhoi the Moon was the `Lord of Light and Life'.
- Among the Xhosa it was believed that `the world ended with the sea, which concealed a vast pit filled with new moons ready for use', i.e. that each new lunation begins with a truly new moon.
- In Bushman legend the moon is a man who has angered the sun. Every month the moon reaches round prosperity, but the sun's knife then cuts away pieces until finally only a tiny piece is left, which the moon pleads should be left for his children. It is from this piece that the moon gradually grows again to become full.

Copyright SAAO 1998

South African Astronomical Observatory

PO Box 9, Observatory, 7935, South Africa

Tel +27 21 447-0025 / Fax +27 21 447-3639

www.saaao.ac.za

22 November 2000



Longitude at Sea

Until the end of the fifteenth century, sailors navigated with almost daily reference to land. In the Mediterranean it was difficult to go very far astray, and in western and northwest Europe navigation was coastal. Ships hugged the shore from Gibraltar to the Norway and the Baltic. The only exception to this rule was the trade between Scandinavia, Iceland, and occasionally Greenland. These routes were discovered (probably by accident) by the Vikings around 1000 CE. With the Portuguese voyages of discovery, in the fifteenth century, navigation became more difficult. For some time Portuguese sailors hugged the coast of Africa, as they carefully explored the contours of this continent. Both the winds and the currents there made sailing south difficult, however, and beginning with the voyages of Diaz (who rounded the Cape of Good Hope) in 1486, Columbus in 1492, and da Gama in 1498, Spanish and Portuguese sailors sailed the high seas for weeks on end without seeing land. How did they know where they were and whether they were on the right course?

The only reference points on the high seas were the stars and Sun. Locations and courses now had to be spatial: a navigator needed to locate himself on a grid of imaginary lines of latitude and longitude.

The Portuguese pioneered the method of navigating by latitude. Ships had to be equipped with instruments (astrolabes, cross staffs) to measure the altitudes of stars or the Sun. It was not difficult to determine one's latitude to within about a degree by this method. Longitude was, however, a different matter. Observations of the Sun and stars were of no immediate help: in order to determine one's longitude with respect to, e.g., Lisbon, one had to find out the difference in local times between one's location and Lisbon. No easy method that was sufficiently accurate suggested itself. The magnitude of the problem is illustrated by the voyage of the Portuguese navigator Cabral who, on his way to the East Indies, swung west in the south Atlantic in order to pick up favorable winds and ran into the coast of Brazil. Further, the world maps prepared in the sixteenth century erred widely in the longitudes of places. The east-west length of the Mediterranean was in error by 19° --about 1100 miles! The longitudes of China and Japan were off by much larger margins. For nations engaged in trade with the East and West

Indies, finding longitude at sea was a matter of national interest. Late in the sixteenth century the Spanish Crown instituted a large prize in the hope of a solution. This initiative was followed by the French, Dutch, and English governments in the seventeenth century.

Soon after the discovery of the [satellites of Jupiter](#), scientists realized that the formation of the satellites provided a clock whose face could be seen from every vantage point. In 1612 Nicholas Claude Fabri de Peiresc in Aix en Provence sent out an observer to the eastern part of the Mediterranean to observe Jupiter's satellites while he did the same at home. The idea was to compare the satellite positions and formations observed on the same day at Aix and, e.g., Tripoli and from these to deduce the difference in local (solar) times between the two locations. Peiresc was, however, disappointed by the results: the positions of the satellites changed too slowly for this purpose. Had the method been more accurate, he had hoped to provide sailors with tables of the motions of the satellites, so that they could carry the standard time reference with them and determine their longitude on the spot. Peiresc now abandoned this effort.

In 1612 Galileo for the first time observed an eclipse of a satellite of Jupiter. When a satellite enters the shadow cone behind the planet it disappears very quickly. Such eclipses were, for all practical purposes, instantaneous events. If a navigator on the high seas could note the local time of such an eclipse and compare it with the local time at which it was predicted to happen at the European reference location, the difference in times and therefore longitude could easily be found. Could sufficiently accurate tables be drawn up?

In 1613 Galileo entered into negotiations with the Spanish Crown to provide Spanish navigators with eclipse tables for the satellites and [telescopes](#) with which to make the observations. He worked for many years to perfect his knowledge of the satellites' motions but never published his results (presumably because they were not sufficiently accurate). He did, however, have reasonable hopes of being able to predict eclipses over short periods. But there was a more severe problem. In order to observe the satellites, one needed a telescope of relatively high power, say 15, and given the small field of view of the Galilean telescope (perhaps 20' of arc) it was impossible to make the observation from the deck of a ship on the high seas. Galileo made some trials of a telescope attached to a helmet (he called this device a *celatone*) on ships riding at anchor in the harbor of Livorno, but this approach only worked with rather low-powered telescopes. The Spanish were not impressed by the method, and negotiations eventually faltered.

Galileo took up the problem again after his trial, and this time he negotiated (through intermediaries) with the States General of the Netherlands, who had just announced their prize. Although the Dutch government admired Galileo greatly, its committee came to the same conclusion its Spanish counterpart had earlier. For his efforts, the States General voted Galileo a gold medal and chain, but Galileo was forbidden by the Inquisition from accepting this award.

By Galileo's death, in 1642, the only tables of the motions of Jupiter's satellites were an inaccurate effort published by [Simon Marius](#) in 1614. The Sicilian astronomer Giovanni Battista Odierna published new

tables in 1654, but these were again not accurate. The first reasonably accurate tables were published by Gian Domenico Cassini in 1668.

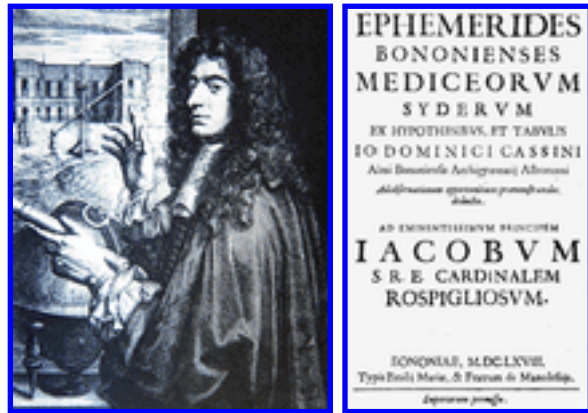

Gian Domenico Cassini and his tables of 1668

It was because of Cassini's tables that the Danish astronomer Oleaue Rømer was able, in 1676, to find a systematic error of about 10 minutes, whose period was equal to the synodic period (opposition to opposition) of Jupiter. Rømer correctly interpreted his result to demonstrate that light does not travel instantaneously. He estimated that it took eleven minutes for light from the Sun to reach the Earth.

Tables--especially those of the motion of the first satellites, whose period is about 42 hours and whose eclipses are therefore most frequent--were now becoming sufficiently accurate to hold out hope that they could be used for determining longitude at sea. The English worked hard--using first the newer astronomical telescope with its larger field of view and then, in the eighteenth century, the reflecting telescope--to make it possible for an observer on a ship to observe the satellites. They went so far as to install gimballed observing seats that were independent of the motion of the ship. But progress was incrementally slow, and in the 1760s a practical solution to the problem of longitude at sea came from the clock-makers: John Harrison had managed to make clocks so accurate and impervious to motion that they could be carried on a ship and not err by more than seconds on a trip to the East Indies. On his first voyage to the South Seas, Captain James Cook took a Harrison chronometer with him and his trials proved this method to be entirely satisfactory.

In the meantime, however, the French had made a different use of satellite eclipses. If it was not feasible to make observations from the deck of a moving ship, it was certainly possible to observe the satellites on land. In the 1670s French astronomers, under the leadership of Cassini, began making observations of the satellites in many locations in France. The resulting map of France, finished in 1679 showed that the west coast of France was too far west by an entire degree on existing maps and that similar adjustments had to be made to the Mediterranean coast. It is said that upon seeing this map, King Louis XIV remarked that he was losing more territory to his astronomers than to his enemies.

The method of determining longitudes by means of observations of the eclipses of Jupiter's satellites was at the center of the revolution in geodesy in the eighteenth century. Travelers and explorers routinely

timed eclipses and sent their results back to Paris and London, to be compared with the observations made there. When Charles Mason and Jeremiah Dixon surveyed the boundary line between Pennsylvania and Maryland, from 1763 to 1767, they used eclipses of the satellites of Jupiter to determine the exact longitudes of places.

Sources

For technical information on tables of the motions of the satellites, see John Roche, "Harriot, Galileo, and Jupiter's Satellites," *Archives Internationales d'Histoire des Sciences* 32(1982):9-51. For a more general treatment, see Susanne Débarbat and Curtis Wilson, "The Galilean Satellites of Jupiter from Galileo to Cassini, Rømer and Bradley," in *The General History of Astronomy*, 4 vols. ed. M. A. Hoskin (Cambridge: Cambridge University Press, 1984-), IIA:144-157. For a brief account of Galileo's negotiations with the Spanish and Dutch governments, see Silvio A. Bedini, *The Pulse of Time: Galileo, the Determination of Longitude, and the Pendulum Clock* (Florence: Leo S. Olschki, 1991), pp. 7-21. See also G. Vanpaemel, "Science Disdained: Galileo and the Problem of Longitude," in *Italian Scientists in the Low Countries in the XVIIth and XVIIIth Centuries*, ed. C. S. Maffeoli and L. C. Palm (Amsterdam: Rodopi, 1989), pp. 111-129. For an eighteenth century trial of the method, see Derek Howse, *Neville Maskelyne, the Seaman's Astronomer* (Cambridge: Cambridge University Press, 1989).



galileo@rice.edu

[Copyright ©1995 Albert Van Helden](#)

Northwest Journal

Our new website has dozens of Canadian fur trade articles online.

Keywords: North West Company, Hudson's Bay Company, David Thompson, Alexander Mackenzie, Peter Fidler, explorers, birchbark canoes, tinsmithing, coppersmithing, blacksmithing, coopering, history, reenactment, country wife, trade gun, trade goods, beaver pelt, finger weaving, recipe, capote, bead, ceinture fléchée, sextant, celestial navigation, nautical astronomy, lunar distance, latitude, longitude, dog sled, character interpretation, Metis, Métis.

You will now be taken to the new *Northwest Journal*
home page

at www.northwestjournal.ca

Please update your bookmarks!

Northwest Journal

[Home](#)

[Article Index](#)

Featured Articles

- ✦ [*A Year in the Life of a Canoe Brigade*](#) NEW
- ✦ [*Making a Birchbark Canoe*](#)
- ✦ [*Capots*](#)
- ✦ [*Fur Post Construction*](#) NEW
- ✦ [*Fur Trade Tents*](#)
- ✦ [*Arms in the Northwest*](#)
- ✦ [*The Strange End of John Fubbister*](#)
- ✦ [*Marking of Pieces*](#) NEW
- ✦ [*A Tale of Three Beads*](#)
- ✦ [*What Voyageurs Wore*](#) NEW
- ✦ [*Basic Tinsmithing*](#)
- ✦ [*Still more articles*](#)

Best of Northwest Journal

- ✦ [*How David Thompson Navigated*](#)
- ✦ [*A Compendium of Material Culture*](#)
- ✦ [*Ceinture Fléchée : Finger Weaving a Voyageur Sash*](#)
- ✦ [*Fast Fires with Flint & Steel*](#)
- ✦ [*The Well-Dressed Explorer*](#)
- ✦ [*Seed Beads in the Northwest*](#)
- ✦ [*The Life of David Thompson*](#)
- ✦ [*Women in the Fur Trade*](#)
- ✦ [*Making a Copper Trade Kettle*](#)



[I want to test my fur trade word power!](#)



[*Northwest Journal*](#)
[*Readers' Forum*](#) NEW



Northwest Journal Online

- ✦ [For teachers and students](#)
- ✦ [Some suggested articles to get started.](#)
- ✦ [What is *Northwest Journal*?](#)
- ✦ [Look at the \[complete index of articles\]\(#\).](#)
- ✦ [Can I copy these articles for my club or class?](#)
- ✦ [How to \[submit articles\]\(#\).](#)
- ✦ [View the \[select bibliography\]\(#\).](#)
- ✦ [About \[subscriptions\]\(#\).](#)
- ✦ [Northwest Journal \[website status & FAQ\]\(#\)](#)
- ✦ [Resource and re-enactor \[links\]\(#\).](#)

Please send us your [comments](#)!

48880

This site last updated 21/02/2002.

Copyright 1994-2002 *Northwest Journal* ISSN 1206-4203. [May I copy this article for my class?](#)

Article Index

U.S. Naval Observatory

Astronomical Applications Department



Sun or Moon Rise / Set Table for One Year

Important! Please read the [Notes section](#).

This page provides a way for you to obtain a table of the times of sunrise/sunset, moonrise/moonset, or the beginning and end of twilight, for one year.

You can obtain a table **for any location worldwide** by following these simple steps:

- Decide on which form to use. If you want a table for cities or towns in the U.S. or its territories, use [Form A](#) below. For other locations, use [Form B](#) below.
- Enter the year for which the table is desired.
- Select the table type (sunrise/sunset, moonrise/moonset, etc.) from the pop-up list in the form that you are using.
- Specify the location of interest using the fields provided on the form.
- Click the "Compute Table" button at the end of the form to compute the table. The table will provide the data requested in local standard time on a 24-hour clock; for example, 1836 means 6:36 p.m., local standard time.
- Be sure to read [Notes section](#) (on this page beyond the two forms) for an explanation of the items in the table.

Form A - Cities or Towns in the U.S.

Specify year, type of table, and place:

Year: Type of table:

State or Territory:

Place Name:

The place name you enter above must be a city or town in the U.S. The place's location will be retrieved from a file with over 22,000 places listed. Either upper- or lower-case letters or a combination can be used. Spell out place name prefixes, as in "East Orange", "Fort Lauderdale", "Mount Vernon", etc. The only exception is "St.", which is entered as an abbreviation with a period, as in "St. Louis".

Form B - Locations Worldwide**Specify year, type of table, and place:**

Year: Type of table:

Place Name:

The place name you enter above is used only in the table header; you can enter any identifier, or none (do not use punctuation characters).

Longitude: east west degrees minutes

Latitude: north south degrees minutes

Time Zone: hours east of Greenwich west of Greenwich

For locations that require it, the time zone can be entered in hours and a fraction. For example, for locations in India, the time zone may be entered as 5.5 hours east of Greenwich. The time zone field can accommodate up to five characters.

Need coordinates? Try NGA's [GEOnet Names Server](#).

NEW! Need U.S. coordinates? Try this [USGS](#) web page.

Need a time zone? Try the [time zone map](#).

Notes



How to Print the Table

The table is 134 characters wide, so to print it you must use **landscape** orientation and **8-point (smallest) type**. Consult your browser's documentation for details on how to change the font/text size. An alternative scheme is to save the table to a file on your computer (for example, in Netscape, click on **File** then **Save As...**), then use your favorite word processor or text editor to print it.

Definitions

For information on the definitions of rise, set, and twilight, see [Rise, Set, and Twilight Definitions](#) in FAQ.

Time Zones

The times of the phenomena are presented in the standard time of the place requested, using the *current* time zone of the place. Standard time in [time zones](#) was introduced in the U.S. in 1883, but the time zone boundaries have evolved considerably since then, with places shifting from one zone to another. There is no attempt here to track such changes.

Daylight Time

Daylight time is not implemented in this program. When [daylight time](#) is in use, add one hour to the times listed in the table.

Legal Use of the Data in the Table

Please see [Astronomical Data Used for Litigation](#) if you are interested in using for legal purposes the data produced by this service.

If you are having trouble seeing the date fields on this page, try the [version without JavaScript](#).

Sunset photo by George Kaplan from Nags Head, North Carolina.

Need other kinds of astronomical information? Start at our [home page](#).

[\[Publications | Data Services | Software | FAQ | Research | About AA\]](#)
[\[News | Site Map | Index | Home\]](#)

[Need help?](#)

Last modified undefined NaN, NaN at NaN:NaN



*Epact:
Scientific Instruments of
Medieval and Renaissance Europe*

*Museum of the History of Science, Oxford · British Museum, London
Museum of the History of Science, Florence · Museum Boerhaave, Leiden*

*Silke Ackermann, Jim Bennett, Marco Beni, Marian Fournier, Rob van Gent, Giles Hudson,
Stephen Johnston, Ilaria Meliconi, Mara Miniati, Franca Principe, Peter Stringer, David Thompson*

| [Introduction](#) | [Essay](#) | [Museums](#) | [Bibliography](#) | [Conventions](#) | [Credits](#) | [Help](#) |
| [Catalogue entries](#) | [Handlist](#) | [Makers](#) | [Places](#) | [Articles](#) | [Glossary](#) | [Search](#) | [Home](#) |



amazon.com



VIEW CART

WISH LIST

YOUR ACCOUNT

HELP

WELCOME

YOUR STORE

BOOKS

APPAREL & ACCESSORIES

ELECTRONICS

TOYS & GAMES

MUSIC

CELL PHONES & SERVICE

SEE MORE STORES

International

New Releases

Top Sellers

Today's Deals

Sell Your Stuff

Hello. Sign in to get [personalized recommendations](#). New customer? [Start here](#).

SEARCH

FREE Super Saver Shipping on orders over \$25!

[Restrictions apply](#)

WEB SEARCH

Powered by A9.com

BROWSE

Add favorites

Featured Stores

- [Apparel & Accessories](#)
- [Electronics](#)
- [Jewelry & Watches](#)

New Stores

In Beta [\(What's this?\)](#)

- [Musical Instruments](#)
- [Gourmet Food](#)
- [Health & Personal Care](#)
- [Beauty](#)
- [Sports & Outdoors](#)

Books, Music, DVD

- [Books](#)
- [DVD](#)
- [Magazine Subscriptions](#)
- [Music](#)
- [Video](#)

Electronics & Office

- [Electronics](#)
- [Audio & Video](#)
- [Camera & Photo](#)
- [Office Products](#)
- [Software](#)
- [Computer & Video Games](#)
- [Computers](#)
- [Cell Phones & Service](#)

Get the Amazon.com Visa® Card Instantly!

Get your card instantly and **Save \$30** today!

Find out how



Fall Fashion: Hot Looks, Cool Savings



Sometimes finding out *how* to look means knowing *where* to look. This fall, discover what's in, what's now, and what's hot in [InStyle](#), [Vogue](#), [Lucky](#), [Cargo](#), and

other top-selling [fashion magazines](#). Plus, for a limited time, subscribe to [select titles](#) and get a \$5 promotional certificate to spend on your next Amazon.com purchase.

▶ [Visit our Magazine Subscriptions Store](#)

Our Favorite Books of the Year... So Far

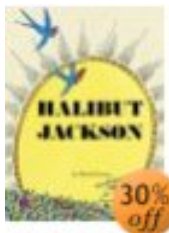

The votes are in! From mountains of new releases, Amazon.com book editors have chosen these winning [fiction](#), [nonfiction](#), and [children's](#) titles as their favorites for

2004--so far. From beach reads to bedtime books, family sagas to fantasy, our list of editors' picks has something for every reader.

- [Editors' Picks: Fiction](#)
- [Editors' Picks: Nonfiction](#)
- [Editors' Picks: Kids & Teens](#)

\$25 Off Tools & Hardware

Save up to 50% on Used Textbooks

Save on Textbooks



Shop Amazon.com for the largest selection and deep discounts

on thousands of new and used textbooks. Plus, it's easy to earn some extra cash by listing your old textbooks for sale. [Visit the New & Used Textbook Store](#).

INTRODUCING THE PARIS HILTON COLLECTION



exclusively at amazon.com

New Releases

Already a customer? [Sign in](#) to see what's [New Releases](#).

New customer?

[Personalize Amazon.com now](#)

New Releases

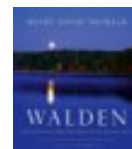

[Walden](#) by Henry David Thoreau

Kids & Baby

- [Toys & Games](#)
- [Baby](#)
- [Imaginarium](#)

Home & Garden

- [Home & Garden](#)
- [Kitchen & Housewares](#)
- [Tools & Hardware](#)
- [Outdoor Living](#)

Gifts & Registries

- [Baby Registry](#)
- [Free e-Cards](#)
- [Gift Certificates](#)
- [Gift Store](#)
- [Wedding Registry](#)
- [Wish List](#)

Amazon.com Services

- [Presidential Candidates](#)
- [Movie Showtimes](#)
- [Cars](#)
- [Corporate Accounts](#)
- [Friends & Favorites](#)
- [In-Store Pickup](#)
- [Restaurants](#)
- [Travel](#)

Bargains

- [Auctions](#)
- [Outlet](#)
- [Used](#)
- [zShops](#)

Featured Partners



Take \$25 off when you purchase \$199 or more of Tools & Hardware products offered by Amazon.com. [Here's how](#). Whether you're working on small projects or taking on major renovations, choose from our huge selection of [power tools](#), [cordless tools](#), [lawn](#)

[and landscaping](#) equipment, and more. Shop today and take \$25 off!

[Celestial Navigation in a Nutshell](#) by Hewitt Schlereth ([Why?](#))

[The Bronze Bow](#) by Elizabeth George Speare ([Why?](#))

[Latitude Hooks and Azimuth Rings](#) by Dennis Fisher ([Why?](#))

[The Complete On-Board Celestial Navigator](#) by George C. Bennett ([Why?](#))

[Celestial Navigation for Yachtsmen](#) by Mary Blewitt ([Why?](#))

New and Future Releases

Rio Carbon 5 GB MP3 Player



From the Manufacturer
Sporting an ultra-thin and tapered design, this tiny MP3 player, about the size of a business card, will slide into any pocket virtually unnoticeable. The Rio Carbon is capable of holding up to 80... [Read more](#)

[Unfit for Command](#) by John E. O'Neill, Jerome R. Corsi

[Logitech MX1000 Laser Cordless Mouse \(931175-0403 \)](#) by Logitech

[Angel - Season Four](#) DVD ~ David Boreanaz

[Garden State](#) ~ Various Artists

Fall into New Washes and Fits from Lucky Brand Jeans

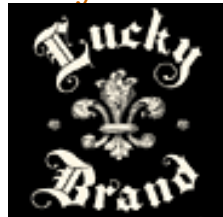

Get great-fitting [Lucky Brand Jeans](#) in a range of dark to weathered washes. Find tattoo-inspired novelty tops, graphic logo sweatshirts, and vintage-look shirts.

▶ [Shop Lucky Brand Jeans at Amazon](#)

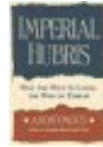

[Imperial Hubris](#) by Anonymous

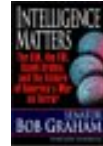

[Intelligence Matters](#) by Bob Graham, Jeff Nussbaum

▶ [More New Releases](#)

\$ Make Money

- [Marketplace](#)
- [Associates](#)
- [Advantage](#)
- [Web Services](#)
- [Paid Placements](#)

▶ [See all services](#)

Special Features

- [Amazon.com Mobile Access](#)
- [Amazon Credit Account](#)
- [Early Adopters](#)
- [Free e-Cards](#)
- [Friends & Favorites](#)
- [Gift Certificates](#)
- [Honor System](#)
- [Purchase Circles](#)
- [Wedding Registry](#)

In Shape and on Track



Our Sports & Outdoors Store is your [exercise and fitness headquarters](#)--with all you need to stay in shape and on track. From home gyms to Pilates gear, and heart rate monitors to supplements, we have the latest from top names like Nautilus,

BodyTrends, Schwinn, and StairMaster.

► [Shop Exercise & Fitness in Sports & Outdoors](#)



Where's My Stuff?

- Track your [recent orders](#).
- View or change your orders in [Your Account](#).

Shipping & Returns

- See our [shipping rates & policies](#).
- [Return](#) an item (here's our [Returns Policy](#)).

Need Help?

- Forgot your password? [Click here](#).
- [Redeem](#) or [buy](#) a gift certificate.
- [Visit our Help department](#).

Search

for

[Top of Page](#)

[Directory of All Stores](#)

Our International Sites: [Canada](#) | [United Kingdom](#) | [Germany](#) | [Japan](#) | [France](#)

[Contact Us](#) | [Help](#) | [Shopping Cart](#) | [Your Account](#) | [Sell Items](#) | [1-Click Settings](#)

[Investor Relations](#) | [Press Releases](#) | [Join Our Staff](#) | [Join Associates](#) | [Join Advantage](#) | [Join Honor System](#)

[Conditions of Use](#) | [Privacy Notice](#) © 1996-2004, Amazon.com, Inc. or its affiliates

The Haven-Finding Art: The History of Navigation from Odyseus to C aptain C ook

E .G .R. T aylor

published by Hollis & C arter, London 1956

T able of C ontents:

Part I: Introduction

1. S igns in the S ky - open-sea voyages - direction by sun and star - direction by winds - home-blowing winds
2. T he S urface and Floor of the S ea - tide and tide-rips - ocean currents and the gulf stream - fogs and fish - sea-floor patterns - danger and safety in-shore

Part II: Navigation without Magnetic C ompass or C hart

3. T he Phoenicians and the G reeks - in soundings - Red S ea sailings - O dyseus and the Phaecians - Pythea of Marseilles - port-books and pilot-books - the ancient wind-rose -sailing the Indian Ocean - sea-marks.
4. T he Irish and the Norseman - monks and anchorites - voyages to Iceland -shore-sighting birds - voyage to G reenland - T he King's Mirror - O cthere and King Alfred.

Part III: With C ompass and C hart

5. In the Mediterranean S ea - lodestone and compass - the new wind-rose - C ompasso da Navigare - C arta Pisana - C atalan C hart-makers - T he T oleta de Marteloio.
6. In the E astern and Western O ceans - Marco Polo - Arab navigators - star altitudes - an E nglish Rutter - navigation by lead and line - tides and tide-tables - three medieval voyages.

Part IV: Instruments and T ables

7. T he Portuguese Pioneers - G reek geography recovered - Prince Henry the Navigator - sailing by altura - taking the sun - the oldest navigating manual - Pierre G arcia's Rutter.
8. T he E rrors of C ompass and Plain C hart - variation of the compass - Dr. Nunez and the true rhumb - John de C astro and deviation - John Rotz and the chart - Martin C ortes' manual.
9. T he E nglish A wakening -foreign pilots in E ngland - Richard C hancellor and John Dee -

Stephen and William Brough - Bourne's Regiment of the Sea - Robert Norman the compass-maker - the 'Waggoner.'

Part V: Towards Mathematical Navigation

10. The True Chart - Thomas Hariot and Edward Wright - the Table of meridional parts mid-latitude sailing - re-knotting the log-line - the learned societies - re-measuring the degree - Edmund Halley's charts - astronomical and nautical tables.

11. The Longitude Solved - the Greenwich and Paris observatories - the mathematical sailor - a Commission for the longitude - the Rouille prizes - Hadley's sextant - the perfect timepiece - Sully and Le Roy - John Harrison - triumph of the chronometer.

Appendix - Navigation in Medieval China

- [Home](#) • [Why Celestial Navigation?](#) • [History](#) • [Navigational Astronomy](#) • [The Theory](#) • [The Practice](#) • [Celnav in the Classroom](#) • [Vikings](#) • [Navigational Instruments](#) • [Wayfinding](#) • [Quotations](#) • [Resources](#) • [Schools](#) • [Dante](#) • [Other Links](#) • [Webmistress](#) •

NOVA
ONLINE[NOVA Home](#) | [NOVA Site Map](#) | [E-mail](#)Lost at Sea—The Search for
Longitude[Longitude Site Map](#)

Secrets of Ancient Navigation

by Peter Tyson

Oak and triple bronze must
have girded the breast of him
who first committed his frail
bark to the angry sea
--Horace, *Odes*



"Aye, mate." One can almost hear the weary assent of countless a hoary sailor upon hearing these words of Horace, almost see the rheumy eye staring distantly as if at some ghost ship on the horizon that only he can see. For the old poet's words ring only too true. In the three or four millennia of seafaring before John Harrison came along, how could mariners know where they were going? The sea is literally without landmarks to guide by, a vast, featureless emptiness ready and more than willing to swallow up the lost and unlucky, leaving no trace save the awful memories of those who survived them.

The first seafarers kept in sight of land; that was the first trick of navigation. Follow the coast. To find an old fishing ground or the way through a shoal, one could line up landmarks, such as a near rock against a distant point on land; doing that in two directions at once gave a more or less precise geometric location on the surface of the sea. Sounding using a lead and line also helped. "When you get 11 fathoms and ooze on the lead, you are a day's journey out from Alexandria," wrote Herodotus in the fourth century B.C. The Greeks even learned to navigate from one island to the next in their archipelago, a Greek word meaning "preëminent sea." They may have followed clouds (which form over land) or odors (which can carry far out to sea).

But what if land were nowhere nearby? The Phoenicians looked to the heavens. The sun moving across the commonly cloudless Mediterranean sky gave them their direction and quarter. The quarters we know today as

east and west the Phoenicians knew as *Asu* (sunrise) and *Ereb* (sunset), labels that live today in the names Asia and Europe. At night, they steered by the stars. At any one time in the year at any one point on the globe, the sun and stars are found above the horizon at certain fixed "heights" -- a distance that mariners can measure with as simple an instrument as one's fingers, laid horizontally atop one another and held at arm's length. The philosopher Thales of Miletos, as the Alexandrian poet Kallimachos recorded, taught Ionian sailors to navigate by the Little Bear constellation fully 600 years before the birth of Christ:

Now to Miletos he steered his course
That was the teaching of old Thales
Who in bygone days gauged the stars
Of the Little Bear by which the Phoenicians
Steered across the seas

The Norsemen had to have other navigational means at their disposal, for in summer the stars effectively do not appear for months on end in the high latitudes. One method they relied on was watching the behavior of birds. A sailor wondering which way land lay could do worse than spying an auk flying past. If the beak of this seabird is full, sea dogs know, it's heading towards its rookery; if empty, it's heading out to sea to fill that beak. One of the first Norwegian sailors to hazard the voyage to Iceland was a man known as Raven-Floki for his habit of keeping ravens aboard his vessel. When he thought he was nearing land, Raven-Floki released the ravens, which he had deliberately starved. Often as not, they flew "as the crow flies" directly toward land, which Raven-Floki would reach simply by following their lead.

Heeding the flightpaths of birds was just one of numerous haven-finding methods employed by the Polynesians, whose navigational feats arguably have never been surpassed. The Polynesians traveled over thousands of miles of trackless ocean to people remote islands throughout the southern Pacific. Modern navigators still scratch their heads in amazement at their accomplishment. Like Eskimos



study the snow, the Polynesians watched the waves, whose direction and type relinquished useful navigational secrets. They followed the faint gleam

cast on the horizon by tiny islets still out of sight below the rim of the world. Seafarers of the Marshall Islands built elaborate maps out of palm twigs and cowrie shells. These ingenious charts, which exist today only in museums, denoted everything from the position of islands to the prevailing direction of the swell.



Statue of Ptolemy.

Charts have aided mariners ever since the Alexandrian astronomer Ptolemy created the first world atlas in the second century A.D. The redoubtable Ptolemy even plotted latitude and longitude lines on his atlas's 27 maps, though the farther one got from the known world centered on the Mediterranean, the dangerously less reliable they became. Even before Ptolemy, there were sailing directions -- the Greeks called them *periplus* or "circumnavigation" -- that were compiled from information collected from sailors far and wide. One of these, *The Periplus of the Eritrean Sea*, a document written in the first century by a Greek merchant living in Alexandria, described trading routes as far east as India. By the 10th century, Italian-made portolans

supplied detailed directions, distances, depths, and coastal descriptions, and by the 13th century, sea maps with scale and bearings began to appear.

The greatest advance in navigation came with the compass. The Chinese apparently knew about the powers of magnetism as early as the third millennium B.C., when, historians tell us, one army defeated another after the battlefield had become enveloped in dense fog by using a device known as a "point-south carriage." This was a standard carriage for carrying royalty with a small, rotating figure mounted on the front, which by magnetism always pointed south. (The Chinese chose to have the arrow point south rather than north.) But no one seems to have manipulated the lodestone for sea navigation until early in the present millennium. The first mention of the compass in the West comes from the Englishman Alexander Neckham, who wrote in 1187 that "sailors use a magnetic needle which swings on a point and shows the direction of the north when the weather is overcast." Despite its usefulness, the compass took a long time to come into wide use, as many seamen thought it operated by black magic. (Hence the invention of the binnacle, in which sea captains could hide their recondite instrument from the suspicious eyes of the crew.) In the meantime, sailors relied on natural forces they could readily comprehend.

One of these was currents. From time immemorial, journeys have been made or broken by these undersea winds. The western-trending currents of the Indian Ocean, for one, are likely responsible for the Indonesian-based race of Madagascar, an African island 4,000 miles from the nearest bit of Indonesia. Similarly, the clockwise currents in the North Atlantic helped doom one of the greatest land scams in history: Erik the Red's colonization scheme for the island he cleverly dubbed "Greenland." Of the 25 ships that sailed west from Norway in the year 990, only 14 arrived. The father of those North Atlantic currents -- the Gulf Stream -- was named by none other than Benjamin Franklin. While deputy Postmaster-General of Great Britain in the 18th century, Franklin noticed that his mail ships to the American colonies took longer than whaling ships. Questioning whalers, he learned of a powerful current originating from the Gulf of Mexico -- hence his name for it -- and sweeping northeast into the North Atlantic (and, incidentally, giving the British Isles a climate positively balmy for such a northern latitude).

Like currents, trade winds have always been important to mariners. Those blowing heads on yellowed old maps were not mere decoration. In the Indian Ocean, for example, Indian traders over the ages have ridden the northeast monsoon to Africa in the cool, dry winter and taken the southwest monsoon back to the subcontinent in the hot, wet summer. To make their annual voyages from Tahiti to Hawaii, a journey of several thousand miles, the Polynesians hitched a ride on the prevailing south-easterly wind, setting a starboard tack and sailing northeast.

For millennia, as sailors from the Phoenicians to the Polynesians knew, the heavens remained the best way to find one's north-south position. Increasingly sophisticated devices were designed over the centuries to measure the height of the sun and stars over the horizon. The gnomon or sun-shadow disk operated like a sundial, enabling the user to determine his latitude by the length of the sun's shadow cast on a disk floating level in water. The Arabian *kamal* was a rectangular plate that one moved closer or farther from one's face until the distance between the North star and the horizon exactly corresponded to the plate's upper and lower edges. The distance the plate lay away from the face -- measured by a string tied to the center of the plate and held at the other end to the tip of the nose -- determined the latitude.

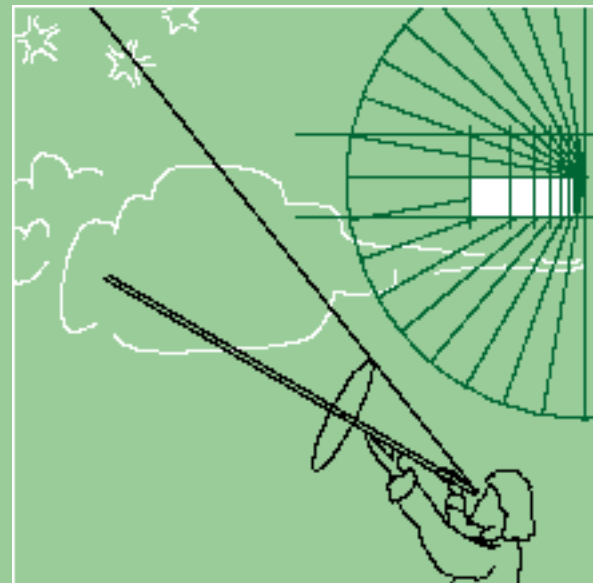

The crossbar

In the Middle Ages, sailors relied on the astrolabe, a disc of metal that one held suspended by a small ring. The disc had a scale with degrees and a ruler for measuring the height of an astronomical body. Other medieval mariners preferred the cross-staff, a T-shaped device whose base was held up to the eye. One measured the sun's height by pulling the slidable top of the T toward one's eye until the sun lay at the top and the horizon at the bottom. Since blindness resulted from frequent use, the explorer John Davis invented the back-staff in 1595, which enabled one to get the same measurement with one's back to the sun. The sextant was the most advanced of these devices, allowing users to determine their latitude to within a sea mile or two, even from a swaying deck.

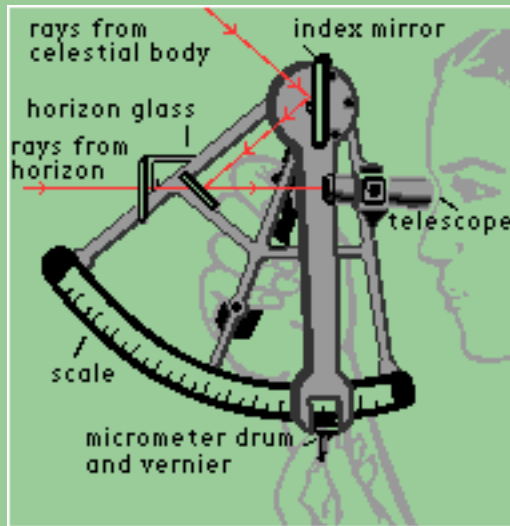

The sextant

In the years after the sextant was invented in 1731, many held out hope that it would aid in east-west navigation as well -- that is, in finding longitude. Sailors could employ the sextant to figure longitude using the lunar-distance method, but with the astronomical tables of the 18th century, the process could take several hours to work out one's position -- not remotely good enough for sea travel. In the end, it was the dogged clockmaker, John Harrison, who solved the longitude problem with his chronometers. And today, the precocious step-child of these highly accurate clocks,

the Global Positioning System, has finally proved the Roman dramatist Seneca right, when he wrote in the first century that

There will come an age in the far-off years
 When Ocean shall unloose the bonds of things,
 When the whole broad earth shall be revealed

Peter Tyson is Online Producer of NOVA.

Photos: (1,2) NOVA/WGBH; (3) Visuals Unlimited/Owon Gingerich.

[Great Challenge](#) | [GPS](#) | [Find Your Longitude](#)
[Ancient Navigators](#) | [Resources](#) | [Teacher's Guide](#)
[Transcript](#) | [Site Map](#) | [Longitude Home](#)

[Editor's Picks](#) | [Previous Sites](#) | [Join Us/E-mail](#) | [TV/Web Schedule](#)

[About NOVA](#) | [Teachers](#) | [Site Map](#) | [Shop](#) | [Jobs](#) | [Search](#) | [To print](#)
[PBS Online](#) | [NOVA Online](#) | [WGBH](#)

© | Updated November 2000

THE
SEAMANS
SECRETS

Devided into two parts.

WHEREIN IS TAUGHT

the three kindes of Sayling, Horizontal,
Paradoxal, and Sayling upon
a Great Circle

Also an Horizontle Tyde-Table for the
easie finding of the Ebbing and Flowing of the
Tydes, with a Regiment newly Calculated for the
finding of the Declination of the Sun, and many
other most necessary Rules and Instruments
not hereforte set by any.

Newly Corrected and ammended, and the
Eighth time printed

Printed by Gartrude Dawson, living in Bartholomews Close,
the second door from the Half Moon Tavern's Alley
that goes into Alderfgast-street, 1657.

+++++

To the right honorable Lord, Charles
Haward, Baron of Effingham, Knight of the noble
Order of the Garter, Lieutenant of her najesties Conties of
Suffix and Surrey, Constable of her Majesties Honour and Castle of
Winsor, Lord high Admiral of England, Ireland, and Wales, and
of the Dominies and fifes of the fame, of the Town of Callis
and Marches thereof, Normandy, Gal oxy, and Greyves, Captain General of
her Jajesties Seas and Navie Royal, and one of her Majesties most
Honourable privie Council, John Davis witheth encrease
of Honour and perfect felicity.

R

ight Hounourable, and my special good
Lord as by the instinct of nature, all men
are desirious of knowledge, and take plea-
sure in the varieties of understanding, so
it is lidewise ingrated by the same bene-
fit of nature, in the hearts of true Nobili-
ty, not only to excel the vulgar fort, but

also to cherish, support, and countenance
all such as shall in due course prosecute
their vocation; and as such practices ei-
ther speculative or mechanical, shall re-

ceive favourable place in the Honourable opinion of Nobility, by so much the more shall the practice be esteemed: which is the cause at this time wmvoulswnwrh mw ro pewawnr unro your most Honorable favor this finall Treatise of Navigation, being a brief collection of such practices as in my several voyages I have from experience collected. Among which in three several attempts for the discovery of the Northwest passage, thereby to find a short and Navigable course into the rech and fameous Countries of Cathyo China, Pegu, the isles Molucan and Phillipins, that thereby to the great and inestimable benefit of our Country, there might be a rich and plentiful trade procured between us and the said Nations, in short time to be performed, and with great sefety in regard to the courte: which action and discovery (by means of that honorable Counseller, Sir Frances Walfingham, Knight, Principal Secretary to her Majesty) was with a good resolution accepted by the Merchants of London, but in the

The Epistle Dedicatory

decay of his honourable life, the attempt was lidewise equaled: but however mens minds alter, yet undoubtedly there is passage Navigable, and easie to be performed by that course (whensorever it shall please God to reveal the same) by invincible reasons ad sufficient experience to be proved: and although before I entred into that discovery, I was sufficiently perswaded of the certainty thereof, by historical relation, substantially confirmed, whereof to the Adventures I made sufficient proof, but especially to my worshipful good friend Mr. William Sanderson, the only Merchant that to his great charges, with most constant travel, did labour for the finishing thereof: yet I thank God that of late it hath been my very good chance, to receive better assurance than ever before of the certainty of that passage, and such was my vehement desire for the performance thereof that whereby I was only induced to go with M. Candish in his second attempt for the South Seas, upon his constant promise unto me, that when we came to Callifornia, I should there have his Pinnace with my own Bark (which for that purpose went with me to my breat charges) to search that Northwest discovery upon those back parts of America, but God hath otherwise disposed our purposes in his divine judgements, for Mr. Candish being half way through the Straits of Magi lane, and impatient of the tempestuous furiosness of that place, having all his Ships and company eith him, returned for Brasil, by the authority of his command, when with a leaking wind we might have passed the same, and returning more than 80 leagues toward Brasil, my self being in his SHip named the Desire without Boat, Oares, Sails, Cables, Cordage, Victuals, or health of my Company sufficient for

that attempt, was separated in a freit of weather, and forced to seek the next shore for my relief, & recovering a Harborow by us named Port Desire, being in the latitude of 48 degr. did there repair my most miserable wants, and there staying four months in the most lamentable distress did again conclude with my Company, to give another attempt to pass the Straits, as my best mean to gain relief. And three times I was in the South Seas but still by furious weather forced back again: yet notwithstanding all this my labour to perform the voyage to his profit, and to save my self (for I did adventure, and my good friends for my sake, 1100 pounds in the action) Mr. Candish was content to account me to be the Author of his overthrow, and to write with his dying hand that I ran from him, when that his own Ship was returned many months before me.

I am bold to make this Relation to your Lordship, only to satisfy your Honour of my conversation, for were I faulty of so foul a crime, I were worthy of ten thousand torments, in presuming to present this Treatise to your Honourable Lordship, and now referring my case to your Lordships consideration, I will again return to my purpose.

In those Northwest voyages, where navigation must be executed in most exquisite sort, in those attempts I was enforced to search all possible measn required in sayling, by which occasion I have gathered together this brief Treatise, which with my self I do dedicate to your honourable protection, being disirous of it lay in my power to do far greater matters in your Loreships service, hoping of your honorable pardon, because it is only done to shew my ditiful affection, and not for any singularity that the work containeth, For I think there be many hundreds in England that can in a far greater measure and more excellent method express the noble art of Navigation, and I am fully persuaded that our Country is not inferiour to any for men of rare knowledge, singular explication, and exquisite execution of the Arts Mathemetick, for what strangers may be compared with Mr. Thomas Digs Esquire, our Country man the great Master of Archmastryu, and for Theorical Speculations and most cunning calculation, Mr Dee and Mr. Thomas Heriotts are hardly to be matched: and for the mechanical practices drawn from the Arts of Mathematic, our Country doth yield men fo principal excellency, as Mr Emery Mullenenx for the exquisite making of Globesbodies, and Mr. Micholas Hellya for the singularity of portrature, have the praise of Europe, Mr Baker for his skill and surpassing grounded knowledge for the building of Ships advantageable to all purposes, hath not in any Nation his equal.

And now that I may return to the Painful Seaman, it is not unknown unto all Nations of the Earth, that the English goeth efore all others in the practices of Sayling, as appeareth by the excellent discovery of Sir Francis Drake in his passages through the Straits of Magilane, which being then so rashly known, he could not have passed, unless he had been a man of great practice asn rare resolution: so much I may boldly say, because I have seen and tasted the frowsrdness of the place, with the great unlikelihood of any pas-

sage to be that way.

I might here repeat the most valiant and excellent attempts of Sir

Hugh Willoughbie, Sir John Hawkins, Sir Humphrey Gilbert, and your Lordships servant, Mr. George Raymond, with divers others that have given most resolute attempts in the practices of Navigation, as well for the discovery as other execution, whereby good proof is made, that not only in the skill of Navigation, but also in the mechanical execution of the practices of sayling, we are not to be matched by any Nation of the earth.

And such Navigtion is the mean whereby Countries are discovered and community drawn between Nation and Nation, the Word of God published to the blessed recovery of the forreign off c_fts, from whence it hath pleased his divine Majesty as yet to detain the brightness of his glory: and that by Navigation Common weilles through mutual trade are not only sufficiently sustained, but mightily enriched; with how great esteem ought the painful Seaman to be embraced, by the whole hard adventures such excellent benefits are achieved, for by his exceeding great hazards the form of the earth, the quantities of Countries, the diversity of Nations, and the natures of Zones, Clumats, Countries and people are apparently made known unto us Besides, the great benefits mutually interchanged between Nations, of such fruits, commodities, and artificial practices, where with God hath blessed each particular country, coast, and Nation, according to the nature and ldituation of the place.

For what hath made the Spaniard to be so great a Monarch, the commander of both Indies, to abound in wealth & all natures benefits but only the painful industry of his subjects in Navigation, their former trade was only figs, oranges, and oyl, but now through Navigtion is brought to be gold, silver, pearls, silks, and spice, by long and painful trade recovered. Which great benefits only by her Majesties loving clemency and merciful favour he doth possisse: for if her Highnesse and her most honoragle Lords would not regard the small distance between her Dominions and those fameous rich Kingdoms, the ea_esse of the passage being once discovered (the North west I mean) with the full sufficiency of her Highnesse subjects to effect the fame, there could then be no doubt, but her stately seat of London should be the store house of Europe, and nurse to all Nations, in yielding all Indian commodities ina far better condition, as a more easie rate than now brought unto us exchanging commodities of our own store, with a plentiful return at the first hand, which now by many exchanges are brought to us.

Then should the Spaniards again return to his old trade, and our Sacred Sovereign be seated the Commander of the earth: which trade and most fortunage discovery, we above all nations ought most principally to regard, because of the singularity and invincible force of our Shipping, which is not the commanding Forttresse of our Country, but also the dread of our Adversary, and the glory of our Nation: wherein we do in no sort flatter our selves, fit it was made apprant to all Nations of the earth, by the late most famous con-

quest that her Majesty had against the huge supposed invincible Fleet of the Spaniard, being by her Navie under the command of your Lordship, who there in person and in place of her Majesty, to your eternal glorious fame did disgrace their glory and confound their force, and manifest their weakenesse by their dastardly flight, through Gods providence and your Lordships stately resolution. Then fifth Navigation is a matter of so great moment, I suppose that every man is bound in duty to give his best furtherance thereunto: among whom as the most unmeet of all, yet wishing all good to the painful traveler, I have published this short Treatise, naming it the Seamans Secrets, because by certain questions demanded and answered, I have not omitted any thing that appertaineth to the secret of Navigation, whereby if there may grow any encrease of knowledge or ease in practice, it is the thing which I chiefly desire. To manifest the necessary conclusions of Navigation in brief and short terms, is my only intent, and therefore I omit to declare the causes of terms and definition of artificial words, as matters superfluous to my purpose, neither have I laid down the cunning conclusions apt for Schollers to practice upon the shore, but only those things that are needfully required in a sufficient Seaman: beseeching your honorable Lordship to pardon my boldnesse, and with your favorable countenance to regard my dutiful affection, I must humbly commit your good Lordship to the mercies of God, who long preserve your health, with continual encrease of honour.

From sandrudge by Dartmouth
the 20, of August, 1594.

Your Lordships in all dutiful
service to Command,

JOHN DAVIS.

(Page completely covered with the cosmology of the earth centered Universe)
(made in a series of 11 concentric circles -- the spheres ??)
(inside to out Luna, Mercurius, Venus, Sol, Mars, Jupiter, Saturnus,
the Firmament, Griftalin, The first movable, Imperiall.)

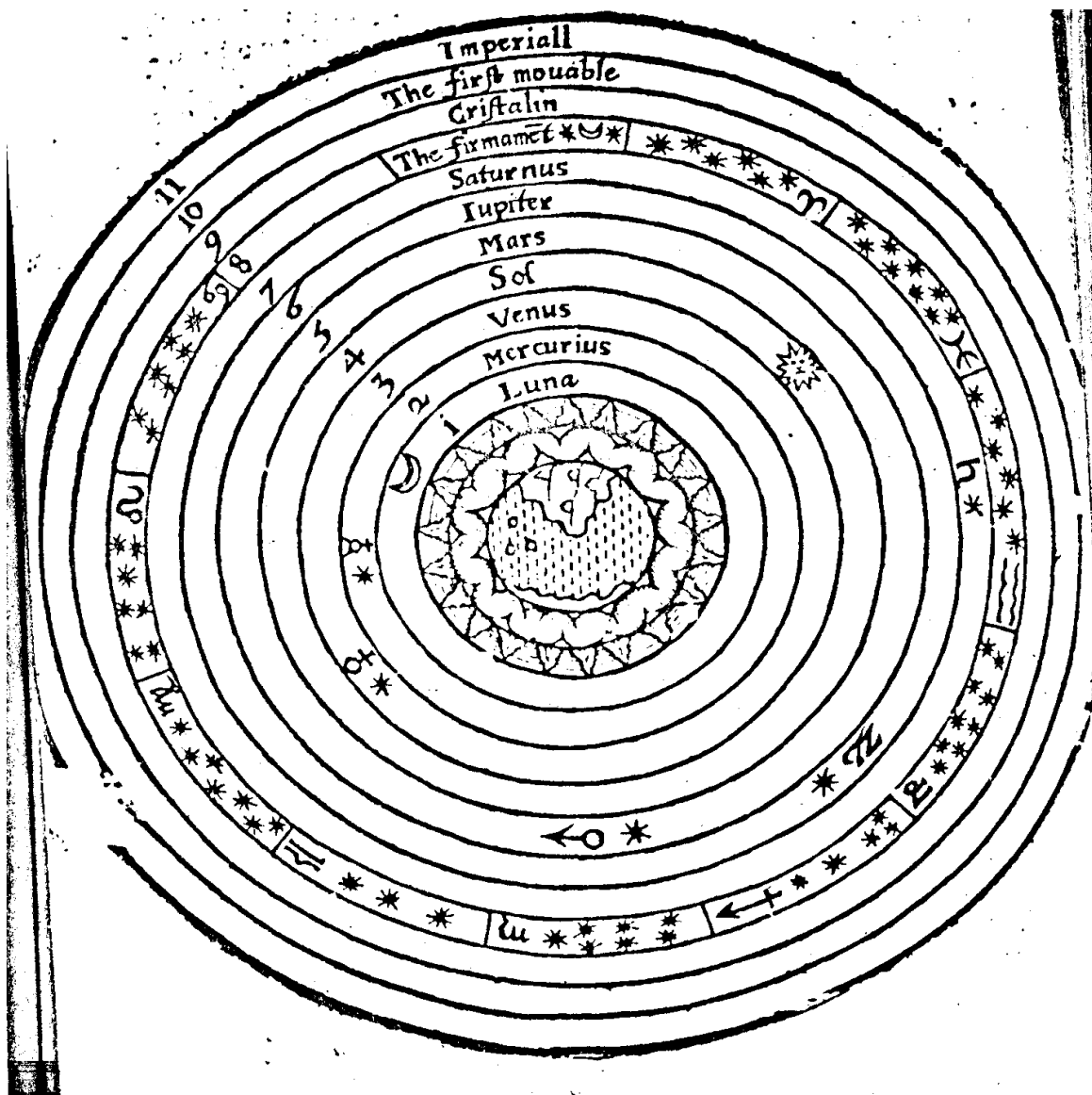

A very necessary
Instrument for
the knowledge
of the Tydes,
mamed an horizontall
Tyde Table.

A very necessary Instrument for the knowledge of the Tydes, named an horizontal Tyde Table.

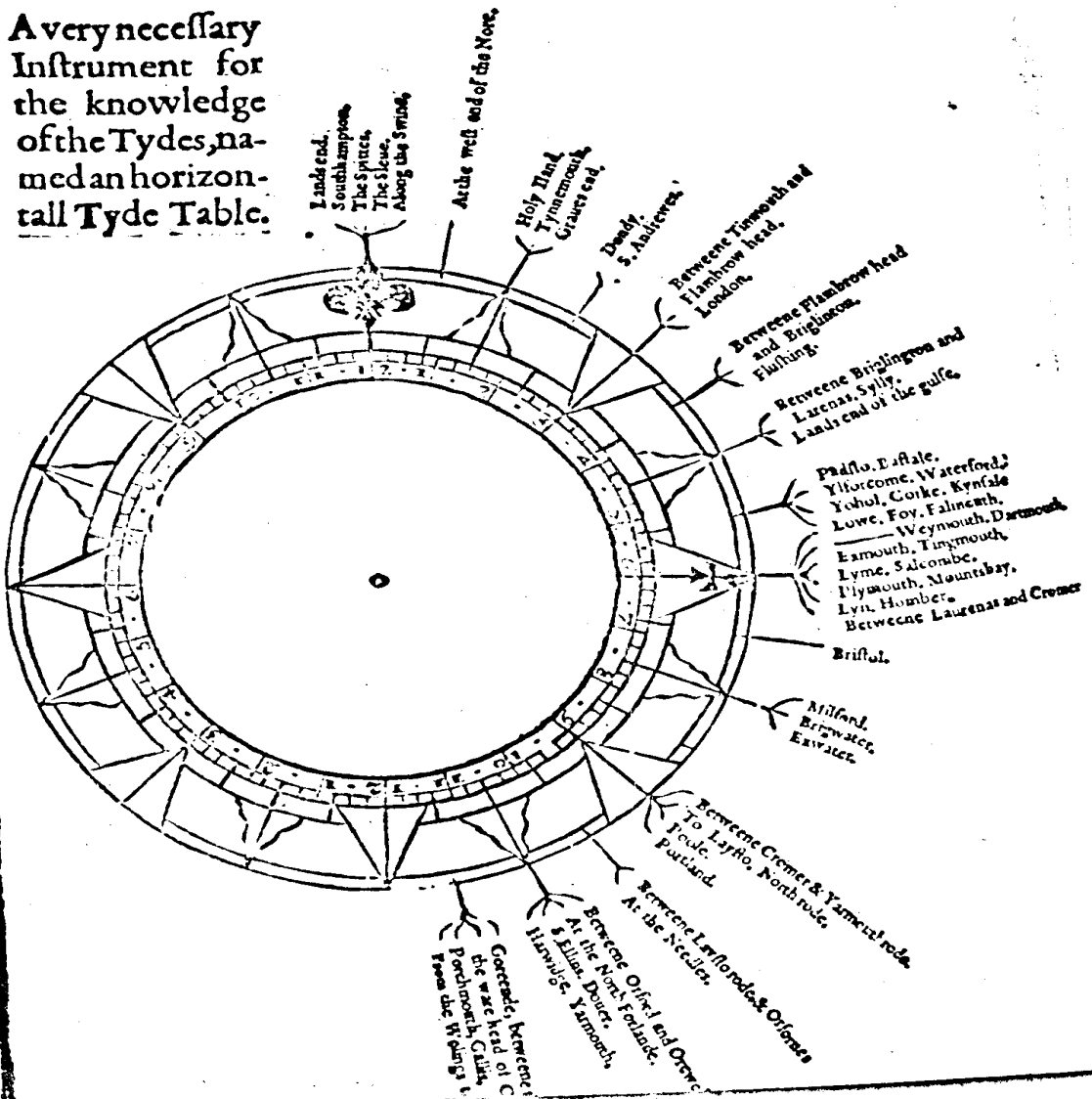

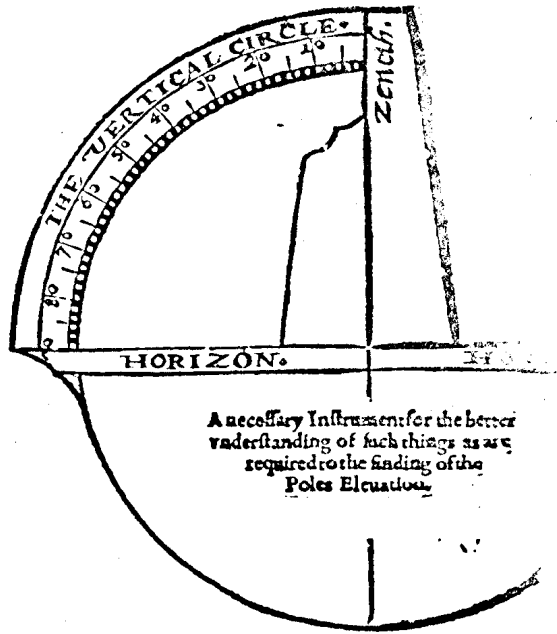
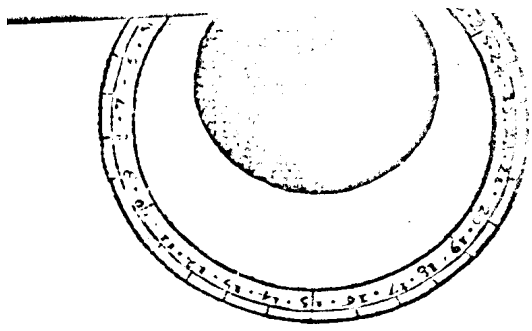

(round instrument for calculating tides)

THE
FIRST BOOK
of the
SEAMANS SECRETS.

What is Navigation ?

Navigation is that excellent Art, which demonstrateth by infallible conclusions, how a sufficient Ship may be conducted the shortest good way from place to place, by Table and Taravers.

What are these infallible Conclusions ?

Navigation consisteth of three parts, which being well understood and practiced, are Conclusions infallible, whereby the skilful pilote is void of all doubt to effect the thing purposed, Of which, the first is the Horizontal Navigation, which manifesteth all the varieties of the Ships motion within the Horizontle plain superficies, where every line drawn is supposed a parallel.

The second is a Paradoral or Cosmographical Navigation, which demonstrateth the true motion of the ship upon any course assigned in longitude, latitude, and distance, either particular or general, and is the skilful gathering together of many Horizontal Corses, into one infallible and true motion Paraboral.

The third is a great Circle Navigation, which teacheth bow upon a great Circle, drawn between any two places assigned (being the only shortest way between place and place) the Ship may be conducted and to performed by the skilful application of Horizontal and Paraboral Navigation.

What is a Corse ?

A Corse is that paraboral line which passeth between place & place, according to the true Horizontal position of the Magnet, upon which line the Ship prosecuting her motion, shall be conducted between the said places.

What is a Travers ?

A travers is the vaiety of alteration of the Ships motion upon the shift of winds within any Horizontal plain supersicies, by the good collection of which Traberses, the SHips uniform motion of Corse is given.

What instruments are necessary for the execution of this excellent skill ?

The Instruments necessary for a skilful Seaman, are a Sea Compass, a Cros-staff, a Quadrant, an Astrolaby, a Chart, an Instrument Magnetical for the finding of the variation of the Compass, an Horizontal plain Sphere, a Globe, and a Paraboral Compass. By which instruments, all conclusions and infallible demonstrations, Hidrographical, Geographical, and Cosmographical, are without controlement of erroz to be performed: But the Sea Compass, Chart and Cros-staff, are instruments sufficient for the Seamans use: the Astrolaby and Quadrant being Instruments very uncertain for Sea-Observations.

What is the Sea Compass ?

The Sea Compass, is a principal Instrument in Navigation, representing and distinguishing the Horizon, so that the Compass may conveniently be named an Artificial Horizon, because by it are manifested all the limits and divisions of the Horizon, required to the perfecture of Navigation, which directions are 32 points of the Compass, where by the Horizon is divided into 32 equal parts, and

every of those points has his proper name, as in the figure following appeareth. Also every point of the Compass both contained degrees minuts, seconds, and Thirds, $\frac{1}{3}$. Which degrees are called degrees of azimuth, whereof there are in every point $1\frac{1}{4}$ so that the whole Compases Horizon containeth 360 degrees of Azimuth, for if you multiply $1\frac{1}{4}$ degrees, the degrees that each point containeth by 32 the points of the compass, it yieldeth 360 the degrees of the Compass. And of minutes each point containeth 45 being $\frac{1}{4}$ of an hour, so that the whole Compass is hereby divided into 24 hours, by which accompt there are in an hour 15 degrees, so that every degree containeth 4 minutes of time, for an hour consisting of 60 minutes hath for his fifteenth part 4 minutes of time, and in every minute there is $\frac{1}{4}$ seconds, and every second contains $\frac{1}{3}$ thirds, either in degrees applies to time or degrees applied to measure: so that the general content of the Compass is 32 points, 365 degrees, and 24 hours with their minutes, seconds and thirds.

What is the use of the 32 Points of the Compass ?

The use of the 32 points of the Compass, is to direct the skilful Pilote by Horizontal Travers, how he may conclude the Course or Paraboral motion of his Ship, thereby with the greater expedition to recover the place desired because they divided the Horizon in such limits as are most apt for Navigation, they do also distinguish the Winds by their proper Names, for the Wind receiveth his name by that part of the Horizon from whence it bloweth.

What is the use of 360 degrees of Azumuth ?

By the degrees of Azumuth is known the quantity of the rising and setting of the Sun, Moon, and Stars, whereby is known the length of the days and nights in all Climates, and at all times; they also show a most precise Horizontle dilination of the motion of the Sun, Moon, and Stars, whereby the certainty of time is measured, and the vairation of the Compass, with the Poles height, is ingeniously known at all times, and in all places with the help of the Globe.

How is the Hour of the Day known by the Compass ?

It hath been an ancient custome among Mariners, to divide the Compass into 24 equal parts, or hours, by which they have been used to distinguish time, supposing an East Sun to 6 of the Clock, a Southeast Sun 9 of the clock, and a South Sun 12 of the clock &c. as in the figure following shall plainly appear. But this account is very absurd, for with us in England (the Sun having his greatest North declination) it is somewhat past 7 of the Clock at an East Sun, and at a Southeast Sun it is past 10 of the Clock: also when the Sun is in the Equinoctial, the Sun is half the day East, and half the day West, to all those that be under the same: so that the Sun then, and to those people useth but 2 points of the Compass to perform the motion of twelve hours: therefore the difinations of time may not well be given by the Compass, unless the Sun be upon the Meridian, so that you be far toward the North, in such places where the Suns Horizontle motion is very oblique, for there the hour may be given by the Compass with-

out any great error, but else-where it cannot. Therefore those that travel must either use the Globe, or an Equinoctial Dial by whom time may be most certainly measured, if there be good consideration of the variation of the Needle by which the Equinoctial Dial is directed, for this is a general thing to be regarded, as well as the Compass, as any Dials, or other Instrument, or conclusion whatsoever whatsoever wherein the use of the Needle is required, that unless there be good regard unto the variation of the same, there can be no god Conclusion follow of any such practices.

(follows compass rose with points named)

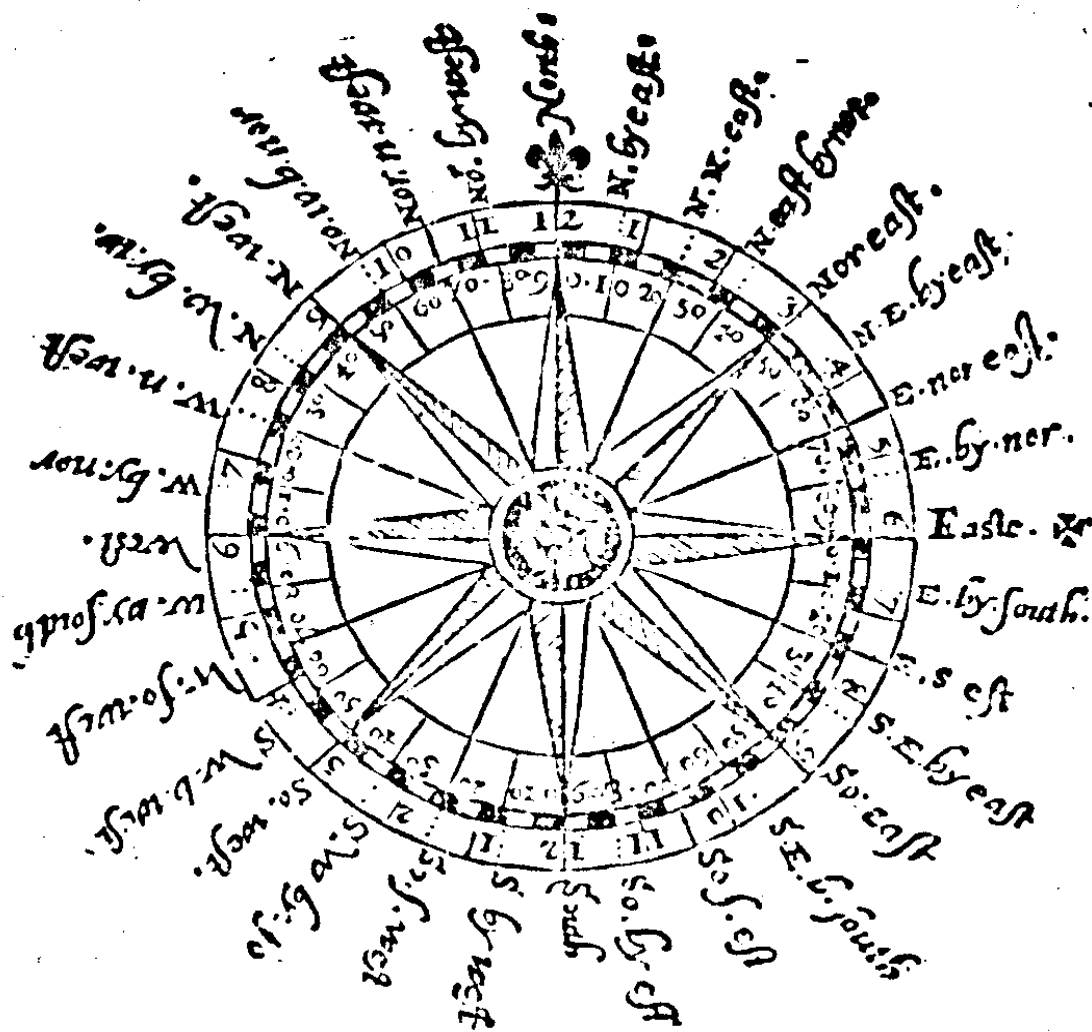

What is the next necessary thing to be learned ?

Having perfectly learned the Compass, the next necessary thing for a Seaman to know, is the alteration or changing of Tydes, that thereby he may with the greater safety bring his ship into any barred Port, Haven, Creek, or other place, where Tydes are to be regarded. And this difference of Tydes in the alteration of flowing and reflowing, is by long experience found to be governed by the Moons motion, for

in such proportion of time as the Moon both separate her self from the Sun, by the swiftness of her natural motien: in the like proportion of time both one Tyde differ from another, therefore to understand this difference of the Moons motion, is the only mean whereby the time of Tyde is most precisely known.

Of the Moons Motion.

Yeu must understand the Moon hath two kinds of Motions: a natural motion, and a violent motion: her violent motion is from the East toward the West, roused by the violent swiftness of the diurnal motion of Primum Mobilie, in which motion the Moon is carried about the Earth in 24 hours and 50 minutes nearest one day with another, for although the diurnal period of the first Mover be performed in 24 hours, yet because the Moon every day __her flowest natural motion moveth 12 degrees, therefore she is not carried about the Earth until that her motion be also carried about, which is in 24 hours and 50 minutes nearest.

Her natural Motion is from the West toward the East, contrary to the motion of the First Mover, wherein the Moon hath three differences of moving, a swift motion, a mean motion, and a flow motion: all which is performed by the Divine Ordinance of the Creator in 27 daies and 8 hours nearest, through all the Deg. of the Zodiack. Her slow Motion is the in the point of Auge or Apogeo, being then farthest distant from the Earth, and then she moveth in every day 12 degrees.

Her swift motion is in the opposite of Auge or Perigeo, being nearest onto the Earth at which times she moveth 14 degrees, with small difference of minutes in every 24 hours.

Between those two Points is her mean Motion, and then she moveth 13 degrees nearest: all which differences are caused by the excentricity of her Orbe wherein she moveth and are only performed in the Zodiack, but the Seamen for their better ease in knowledge of the Tydes, have applied this the Moons motion to the points, degrees, and minutes of the Compass, wherebyf they have framed it to be an Horizontle motion, which __uth by long practice is found to be a rule of such certainty, as that the arror thereof bringeth no danger to the expert Seaman, therefore it is not amis to follow their practised precepts therein.

In every 29 dayes 12 hours 44 minutes, with another through the year, the Sun and Moon are in conjunction and therefore that is the quantity of time between Change and Change, for although the Moon in 27 days and 8 hours, performing her natural motion, both return to the same minute of the Zodiack from whence she departed, yet being so returned, she doth not find the Sun in that part of the Eliptick where she left him, for the Sun in his natural motion moving every day 1 degree toward the East, is moved so far from the place where the Moon left him, as that the moon cannot overtake the Sun to come in Conjunction with him, until she have performed the motion of 2 days 4 hours, and 44 minutes nearest, more than her natural revolution, and that is the Cause wherefore there are 29 days 12 hours, 44

minutes between Change and Change one with another through the whole year: but the Seaman accomp_eth the Moons motion to be uniform in all places of teh Zodiac alike, limiting her general separation from the Sun to be such as is her slowest natural motion, which is 12 degrees, or 48 minutes of time, and in every 24 hours.

By which accompt there are 30 dayes reckoned between the Change and Change, being 11 hours, 16 minutes, more than in truth there is: but because this difference breedeth but small error in their accompt of Tydes, therefore to alter practised Rules where there is no urgent cause, were a matter frivolous, which considered I think it not amiss that we proceed therein by the same method that commonly is exercised

Allowing the Mood in every 24 hours to depart from the Sun 12 degrees, or 48 minutes of time, and in this separation, the Moon moveth from the Sun Eastward, until she be at the Full: for between the Change and the Full, it is called the Moons separation from the Sun: for after the Full, she both apply towards the Sun, so that between the Full and the Change, it is called the Moons Application to the Sun, in which time of Application she is to the Westward of the Sun, as in her separation she is to the Eastward, or I may say in the Seamans phrase all the time of her application is before the Sun, and in the time of her separation she is abaft the Sun.

Then if the Moon do move 48 minutes of time in 24 hours, it followeth that she doth move 24 minutes in 12 hours, and in 6 hours she moveth 12 minutes: therefore every hour she moveth 2 minutes, and such as is the difference of her motion such is the alteration of the Tydes, and therefore every Tyde differeth from the other 12 minutes, because there is 6 hours between Tyde and Tyde: and in every hour the course of flowing or reflowing altereth 2 minutes, whereby it appeareth that in 24 hours the four Tydes of flowing and reflowing do differ 48 min. of time. Anduth the whole knowledge of this difference or alteration of Tydes, as also the quantity of the Moons Separation and Application to, and from the Sun, dependeth upon the knowledge of the Moons age, it is therefore necessary, that next you learn how the Sun may be known.

For the performance whereof, there are two Numbers especially required named the Prime and the Epact, for by the Prime the Epact is]* found, and by help of the Epact the Moons age is known.]

Of the Prime, or Golden Number.

The Prime is the space of 19 years in which the Moon performeth all the varities of her motion with the Sun, at the end of 19 years beginneth the same Revolution again, therefore the prime never accedith the number of 19 and this Prime both always begin in January, and thus the Prime is found: Unto the year of the Lord wherein you desire to know the Prime, add 1, then divide that number by 19, and the remaining number which commeth not into the quotient is the Prime.

Example: In the year of our Lord 1590, I desire to know the Prime, therefore I added 1 unto that year, and then it is 1591, which I divided by 19, and it yieldeth in the Quotient 83, and there remaineth 14 upon the division, which cometh not into the Quotient which 14 is the Prime in the year of our Lord 1590.

```

1
1590 4
1 774
_____ 1591 (83
1591 199 ???
x
    
```

The Epact is a number proceeding from the over-plus of the Solar and Lunar year, which number never exceedith 30, because the Moons age never exceedith 30, for the finding whereof this number only serveth: and thus the Epact is known, which Epact doth always begin in March, multiply the prime by 11 (being the nearest difference between the Solar and Lunar year) divide the product by 30 and the remainder is the Epact. Example : In the year of our Lord 1590 I would know the Epact, first I seek the Prime of that year, and find it to be 14, I therefore multiply, 14 by 11 and that yieldeth 154, which being divided by 30, it giveth the quotient 5, and there remaineth 4 upon the division, which 4 is the Epact in the year 1594, which beginning in March, both continue until the next March of the year 1591.

```

14
11 25 (4(5
_____ 30
14
14
_____
154
    
```

 * Note: these 3 lines were not in the 1643 edition.

Epact = intercalary. a) The period of about 11 days by which the solar year exceeds the lunar year of 12 months.
 b) The age, in days, of the calendar moon on the first of the year.

Of the Solar and Lunar Year.

The Solar year, or the Suns year, consisteth of 12 months, being 365 days and about 6 hours, the Lunar year or the Moons year, containeth 12 moons, and every moon hath 29 days, 12 hours, 44 minutes nearest, which amount unto 354 days, 5 hours, 28 minutes, the content of the Lunar year, which being subtracted from 365 days, 6 hours, there resteth 11 days and 23 minutes, the difference between the said years, from which difference the Epact commeth.
 By this Table the Prime and Epact may forever be found, for when

the year be expired, you may begin again and continue it forever at your pleasure.

(insert circular diagram)

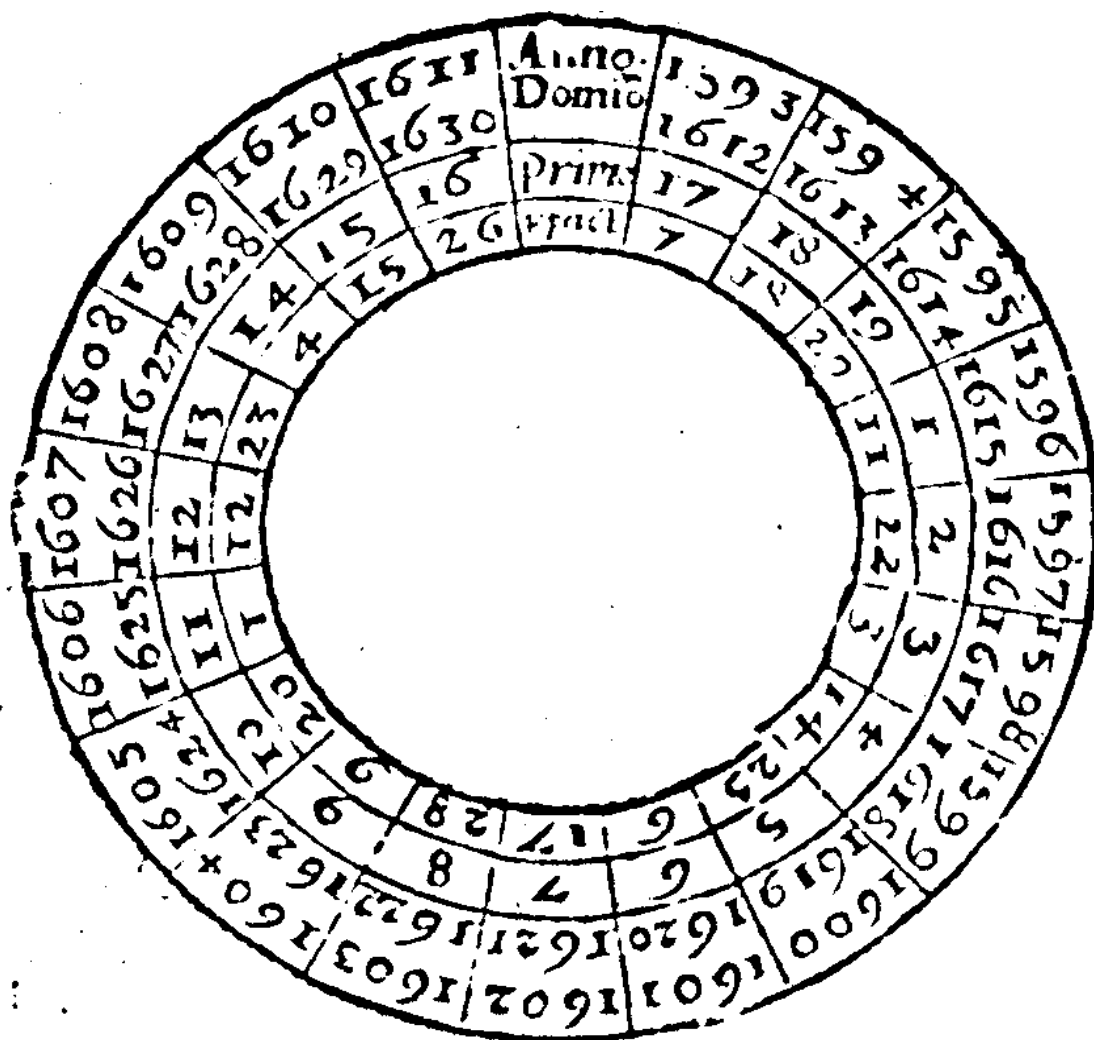

The first Circle containeth Years of our Lord, the second the Prime, and the third and inner Circle sheweth the Epact: under every year you shall find his Prime and Epact, the Prime beginneth in January, and the Epact in March.

How to find out the Moons Age:

First, Consider the day of the Month wherein you seek the Moons age, then note how many Months there are between the said Month and March, including both Months, unto those Numbers add the Epact of that year, that is, you must add into the one sum the day of the Month,

between March and your Month, reckoning both Months and the Epact, all which numbers joynd together, if they exceed* not 30 is the Moons age, if they be more than 30, cast away 30 as often as you can, and the remainder is the Moons age, if it be just 30 it is then New Moon, of the last Quarter day, if 15 it is Full Moon, if 22 it is then the last Quarter day, and thus the Moons age is found forever. And now being able for all times either past, present, or to come, to give the Moons age, I think it good by a few Questions convenient for the Seamans practice, to make you understand the necessary use thereof.

For the account of Tydes.

When you desire to know the time of Full Sea in any place at all such seasons as occasion shall require, you must first learn what Moon maketh a Full Sea in the same place, that is, upon what point of the Compass the Moon is, when it is Full Sea at the said place, you must also know what hour is appropriated* to that point of the Compass as before is shewed: For upon the Change day it will always be Full Sea in that place, at the same instant of time, by which considerations you must thus proceed for the search of Tydes.

Multiply the Moons age by 4, divide the product by 5, and to the Quotient adde the hour, which maketh Full Sea in that place upon the Change day: if it exceed 12, cast away 12 as oft as you may, and then the hour of Full Sea remaineth: and for every 1 that resteth upon your Division, allow 12 minutes to be added to the hours, for 2. 24 minutes: for 3, 36: and for 4, 48 minutes: for more then 4 will never remain: and thus you may know your Tydes to a minute:

Example: The Moon being 12 days old, I desire to know the time of Full Sea at London: First it is found by experience, that a Southwest and Northeast Moon makes Full Sea at London: next I consider that 3 of the Clock is the hour appropriated to that point of the Compass, which number I keep in memory, then I multiply the Moons age, being 12 by 4, and that yieldeth 48, which being divided by 5, it giveth the Quotient 9, and 3 remaineth: I adde the Quotient 9 to the hour* 3 and it maketh 12 hours: and for the remaining number 3, I also adde 36 minutes so that I find when the Moon is 12 days old, it is 12 of the Clock and 36 minutes past, at the instant of the Full Sea at London: & by this order you may at all places & times know the certainty of your Tydes at your pleasure.

But those that are not practiced in Arithmatick, may account these Tydes in this sort, knowing how many daies old the Moon is he must place the Moon upon that point of the Compass which maketh Full Sea at the place desired, & then reckoning from that point with the Sun according to the diurnal motion, must account to many points, and so many times 3 minutes, and there finding the Sun, he must consider what is the hour allowed to that point where he findeth the Sun, for that is the Hour of Full Sea.

As for Example: The Moon being 12 daies old, I desire to know the hour of Full Sea at London, now finding by former experience,

that a Southwest Moon maketh Full Sea at London, I Therefore place the Moon upon the point Southwest, then I account from the point Southwest 12 points, reckoning with the Sun according to the diurnal motion, Southwest and by West for the first point, West Southwest for the second, West by South for the third, West for the fourth point, and so forth, until I come to North, which is 12 points from the Southwest, and because the Moon moveth 3 minutes more than a point in every day, I therefore add 3 times twelve which make 36 minutes to the point North, at which place I find the Sun to be, and knowing that 12 of the clock is appropriated to the point North. I may therefore boldly say that at twelve of the Clock 26 minutes past, it is Full Sea at London, when the Moon is 12 days old, which 36 minutes are added, because the Moon hath moved 36 minutes more than 12 points in those 12 days, which is 1 point and 3 minutes for every day, as before.

Here followeth a very necessary Instrument for the knowledge of the Tydes, named An Horizontle Tyde-Table.

Of this Instrument, and his Parts.

This necessary Instrument for the young practicing Seamans use, named, a Horizontle-Tyde-Table, whereby he may shift his Sun and Moon (as they term it) and know the time of his Tydes with ease and very certainly. (Besides the answering of may pleasant and

necessary Questions used among Mariners) I have contrived into this method, only for the benefit of such young practicers in Navigation.

The first part of this Instrument is a a Sea Compass, divided into 32 points, or equal parts: the innermost circle of which Compass is divided into 24 hours, and every of those into 4 quarters, each quarter being 15 minutes, and against every point of the Compass those places are layd down, in which places it is Full Sea when the Moon cometh upon the same point, so that whatsoever is required as touching time, or the points of the Compass is there to be known.

The next movabl circle upon this Compass, is limited to the Sun, upon whose Index the Sun is laid down, which Circle is divided into 30 equal parts or days, signifying the 30 days between Change and Change according to the Seamans account, so that whatsoever is demanded as touching the age of the Moon, is upon that Circle to be known,

The uppermost moveable Circle is applied to the Moon upon whose Index the Moon is laid down, which is to be placed either to the points and parts of the Compass, or to the time of her age, as the Question requireth: which considered, the use of this Instrument is largely ma-

nifested, by these Questions and their Answers following.

How to know the hour of the Night by the Moon,
being upon any point of the Compass
by this Instrument.

1. Q. The Moon 10 days old, I demand what is a Clock when she is East Northeast ?

1. A. In this Question the Moons age and the point of the Compass is given, thereby to know the hour, I therefore place the Index of the Moon upon the point East Northeast, there keeping the same not to be moved, then because the Moon is 10 days old, I move the Index of the Sun until I bring the 10 day of the Moons age unto the Index of the Moon, and there I look by the Index of the Sun, and find upon the Compass that it is 12 of the Clock at noon and 30 minutes past, when the Moon is upon the point East Northeast, being 10 days old.

2. Q. The Moon being 12 days old I demand at what hour she will be upon the point S.S.E ?

2. A. In this Question the point of the Compass and Moons age is given as in the first, therefore I place the Index of the Moon upon the point S.S.E. And there holding it without moving, I turn the Index of the Sun, until the twelfth day of the Moons age come to the Index of the Moon, and then the Index of the Sun showeth me upon the Horizon the hour 8 therefore I say that 8 of the clock at night, the Moon was upon the point South Southeast.

And thus you may at all times know the hour of the night by the Moon, upon any point of the Compass, so that the Moons age be also had.

How by this Instruction, you may know at all times upon
what point of the Compass the Moon is.

1. Q. When the Moon is 10 days old, upon what point of the Compass shall be at 9 of the Clock in the morning ?

1. A. In this Question the hour of the day and the Moons age is given, thereby to find upon what point of the Compass she is at the same time. I therefore place the Index of the Sun upon the Compass, at the hour 9 of the Clock in the morning being upon the point Southeast, then I turn the Index of the Moon until I bring it to the 10 day of her age, and then I see upon the Compass, that the Moon is North and by East, and 15 minutes to the Eastwards, of the 9 of the Clock when she is 10 days old.

2. Q. When the Moon is 20 days old, upon what point of the Compass will she be at 2 of the Clock in the afternoon ?

2. A. I place the Index of the Sun upon the hour 2, noted in the

Compass, there holding the same without moving, then I turn the Index of the Moon until I bring it unto the 20 day of her age, and there I see upon the Compass that she is Northeast and by North, and 15 minutes to the Northward, at 2 of the Clock in the afternoon, when she is 20 days old.

To find the Moons age by this Instrument.

1. Q. When the Moon is North at 7 of the Clock in the forenoon how old is she ?

1. A. In this Question the point of the Compass and the hour is given, for the finding of the Moons age: therefore I set the Index of the Sun upon the hour 7 in the forenoon, there holding it without moving, then I bring the Index of the Moon to the point North, and then upon the Circle containing the dayes of the Moons age, I see the Moon is 8 dayes, and about 18 hours old, when she is North at 7 of the Clock in the forenoon.

2. Q. When the Sun is East, and the Moon Southeast, how old is the Moon.

2. A. In this Question the points of the Compass are only given for the finding of the Moons age, therefore I set the Index of the Sun upon the point East, there holding him steady, then I put the Index of the Moon upon the point Southwest, and there I see that the Moon is 18 dayes and 19 hours old, when the Sun is East, and the Southwest.

After this order by the variety of these few Questions, you may frame unto your self many other pleasant and necessary Questions, which are very easily answered by this Instrument: and entering into the reasons of their Answers, you may very readily by a little practice, be able by memory to Answer all such Questions with ease.

How to know the time of your Tydes by this Instrument.

1. Q. When the Moon is 12 days old, I desire to know the time of full Sea at London.

1. A. To answer this Question, I first look through all the points of the Compass of my Instrument, until I find where London is written, for when the Moon cometh upon the point of the Compass, it will then be full Sea at London: Therefore I place the Index of the Moon upon the same point, which I find to be Southwest of Northeast there holding the Index not to be moved, then I turn the Index of the Sun until I bring the 12 day of the Moons age to the Index of the Moon, and then the Index of the Sun sheweth me that at 12 of the Clock 36 minutes past it is full sea at London, the Moon being 12 days old.

2. Q. The Moon being 21 days old, at what time is it Full Sea at Dartmouth.

2. A. I find upon my Instrument that Dartmouth is noted upon the points East and West, whereby I know that when the Moon is East or West, it is always Full Sea at Dartmouth: Therefore I place the Index of the Moon upon the point East, and there holding it without moving, I turn the Index of the Sun, until I bring the 21 day of the Moons age unto the Index of the Moon, and the Index of the Sun sheweth me upon the Compass, that at 10 of the clock and 48 minutes past, it is Full Sea at Dartmouth, when the Moon is 21 days old, and not only at Dartmouth, bur my Instrument sheweth me that at the same instant it is full Sea at Exmouth, Weymouth, Plymouth, Mounts Bay, at Linne, and at Humber: and thus with great facility the time of flowings and reflowings is most precisely known.

And now that there may be a final end of the uses and effects of the Compass, it is convenient that I make known unto you how many leagues shall be sailed upon every particular point of the Compass, for the raising or laying of the degrees of latitude, and in the distance sailing how far you shall be separated from the meridian from whence the said courses are begun, for as every point of the Compass hath his certain limited distance for the degrees of the Pole elevation, so do they likewise lead from longitude to longitude, every point according to his ratable limits, which differnces of leagues are without alteration, keeping one and the same positon in every particular Horizon of any latitude, but the degrees of longitude answerable to such distances, do differ in every altitude, according to the nature of the parallel, as hereafter shall be more plainly manifested.

And now know that in sailing North and South, you depart not from your meridian, and in every 20 leagues sailing you raiseth a degree: North and by East raiseth a degree in sailing 20 leagues and one mile, and leadeth from the meridian 4 leagues: North-North-east raiseth a degree in sailing 21 leagues and 2 miles, leadeth from the meridian 8 leagues and 1 mile: Northeast by North, raiseth a degree in sailing 24 leagues, and leadeth from the meridian 13 leagues and a mile: NorthEast raiseth a degree in sailing 28 leagues and a mile, and leadeth from the meridian 20 leagues: Northeast by East raiseth a degree in sailing 36 leagues, and leadeth from the meridian 30 leagues, East North East raiseth a degree in sailing 52 leagues and a mile, and leadeth from the meridian 48 leagues and 2 miles: East and by North raiseth a degree in sailing 102 leagues and a mile, and leadeth from the meridian 100 leagues and 2 miles: East and West do no raise or lay the Pole, but keep still in the same Parallel: The like allowance is to be given every quarter of the Compass, as is laid down upon this Northeast quarter.

||
||
||
||
||
||

||

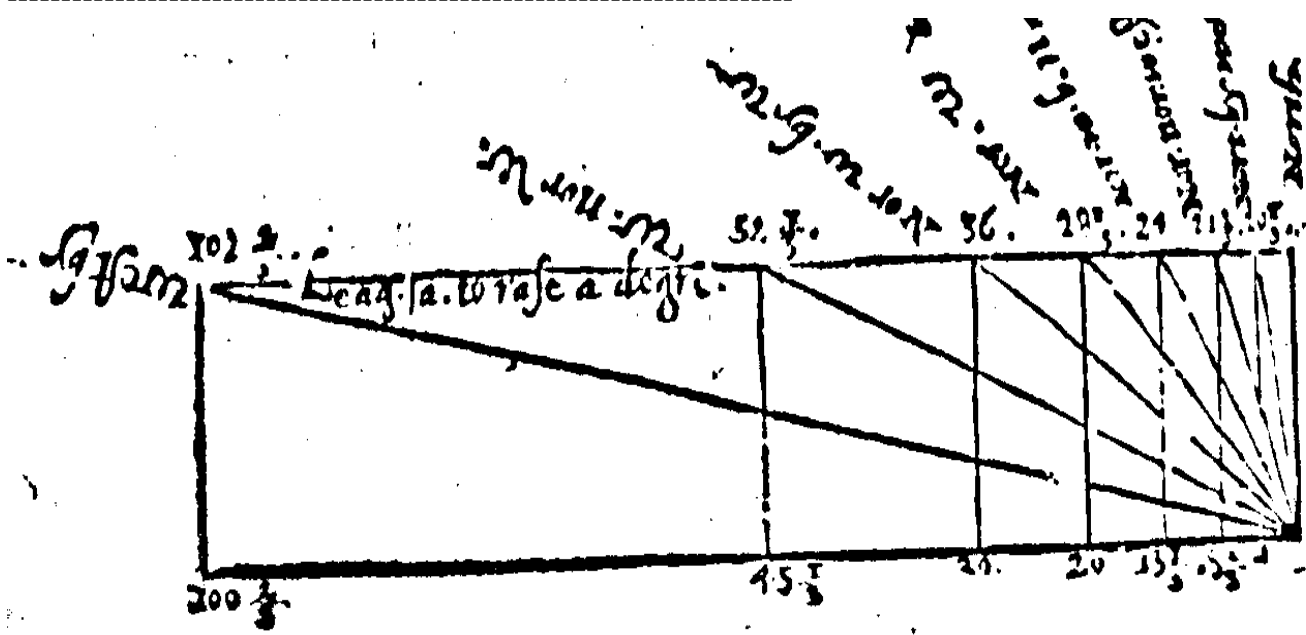

Leagues separated from the Meridian in raising a degree.

Q. I perceive that degrees are to great purpose in Navigation.

Leagues separated from the Meridian in raising a degree.

Q. I perceive that degrees are to great purpose in Navigation.

What is a degree ?

Answ. It is most true that Degrees are of very great employment in Navigation, and a Degree is the 360 part of a Circle, how big or litle soever the Circle be, being applied after the several sorts, for the better perfections of the practises Gubernautick, so that there be degrees of Longitude, degrees of Latitude degrees of Azumuth, degrees of Altitude, degrees applied to Measure and degrees applied to Time.

A Degree of Longitude is the 360 part of the Equinoctial.

A Degree of Latitude is the 360 part of the Meridian.

A Degree of Azumuth is the 360 part of the Compass, or Horizon.

A Degree of Altitude is the 90 part of the Vertical Circle, or the 90 part of the distance between the Zenith and the Horizon.

Every Degree applied to measure, doth contain 60 minutes, and every minute 60 seconds, and every second 60 thirds etc. and every degree of a great Circle so applied containeth 20 leagues, which is 60

miles, so that every minute standeth for a Time in the accompt of measures, and a mile is limited to be 1000 paces, every pace 5 foot, every foot 10 inches, and every inch 3 barley corns dry and round, after our English accompt, which for the use of Navigation is the only best of all other: So by these rates of measure you may prove that a Degree is 20 leagues, or 60 miles, a minute is a mile, or 5000 feet, a second is 83 feet, and 2 thirds; and a third is 16 inches and 2 thirds: and thus much of a Degrees and their parts applied to measure.

Of Degrees applied to Time, there are 15 contained in every hour, so that every degree of Time standeth in the accompt of Time for four minutes, for an hour consisth of 60 minutes of Time, hath for his fifteenth part 4 minutes, so that a degree being the fifteenth part of an hour, containeth 4 minutes of time so that 15 degrees, or 60 minutes make an hour, 24 hours make a natural day, and 365 days 6 hours are contained in a year: and thus much as touching Time and Degrees applied to Time.

What is the use of Degrees ?

The use of a Degree is to measure between place and place, to find Altitudes, Latitudes, and Longitudes, to describe Countries, to distinguish Courses, to find the variation of the Compass, to measure time, to find the places and motions of all Celestial Bodies, as the Sun, Moon, Planets, and Stars: To conclude, by Degrees have been performed all Mathematical observations whatsoever, whose use is infinite.

What is the Poles Altitude, and how it may be known.

Altitude is the distance, height, or mounting of one thing above another, so that the Altitude of the Pole, is the distance, height, of mounting of the Pole from the Horizon, and is defined to be that position of the Meridian which is contained between the Pole and the Horizon, which Altitude or Elevation is to be found either by the Sun, or by the fixed Stars, with the help of your Cross-Staff, Quadrant, or Astrolaby, but the Cross-Staff is the only best Instrument for the Seamans use.

And in the observation of this Altitude there are five things especially to be regarded: the first is, that you know your Meridian distance between your Zenith and the Sun or Stars, which by your Cross-Staff or Astrolaby is given: the second, that the declination be truly known at the time of your observation. And the other three are, that you consider whether your Zenith be between the the Equinoctial and the Sun or Stars, or whether they be between your Zenith and the Equator, for there is a several order of working upon each of these differences.

Latitude you must also know, That so much as the Pole is above the Horizon, so much is the Zenith from the Equinoctial, and this distance between the Zenith and the Equator is called Latitude or wideness, and is that position of the Meridian which is included between your Zenith and the Equator: for it is a general Rule for ever, That so much as the Pole is above the Horizon, so much the Zenith is from the Equinoctial: so that in this sense, Altitude and Latitude is all one

thing, the one having relation to that part of the meridian, contained between the Pole and the Horizon: and the other to that part of the meridian which is contained between the Zenith and the Equinoctial. You must further understand, that between the Zenith and Hroizon, it is a quarter of a great Circle containing 90 degrees so that knowing how much the Sun or any Star is from the Horizon, if you take that distance from 90, the remainder is the distance between the said Body, and the Zenith.

As for Example: If the Sun be 40 degrees 37 munutes from the horizon, I subrtact 40 degrees 37 minutes from 90, and there remaineth 49 degrees 23 minutes, which is the differance between my Zenith and the SUn, &tc. Those Instruments that begin toe accompt of their degrees at the Zenith, concluding 90 in the Horizon, are most ease for the finding of the Latitude by the Sun or fixed Stars, because they give the difference between the Zenith and the Body observed without further trouble, and that is the number which you must have, and for which you do search in your Observation: All which things considered, you must in this sort proceed for the finding of the Poles height or Al-titude.

By the Sun, or fixed Stars, being between the Zenith
and the Equinoctial, the Latitude is thus found,
in what part of the world soever
you be.

First, Place the Cross-Staff to your Eye, in such good sort as that there may grow no error by the disorderly using thereof, for unless the Center of your Staff, and the Center of your Sight do joyn together in your observation, it will be erroneous what you conclude thereby: Your Staff so ordered, then move the Transversary upon your Staff to and fro as occasion requireth, until at one and the same instant you may set by the upper edge of your Transversary, halfe the body of the Sun, or Stars, or that the lower edge of or end thereof so likewise touch the Horizon, at that place where it seemeth that the skie and the Seas are joyned, having special regard in this your observation, as that you hold the Transversary as directly uprightly as possible you may, and you must begin this observation somewhat before the Sun or Stars be at South, and continue the same so long as you percieve that they rise: for when they are at the biggest, then are they upon the Meridian, and then you have the Merioninal altitude which you seek, at which time they will bedue South from you if your Compass be be good and without variation, and then both the Transversary shew upon the staff the degrees and minutes that the said body is from your Zenith, if the degrees of your instrument be numbered from the Zeinith toward the Horizon: or else it shewith the distance between the said body and the Horizon, if the degrees of your Instument be numbered from the Horizon, concluding 90 in the Zenith, as commonly Cross-Staffs are marked, which is not the easiest way: but if your staff be a accompted from the Horizon, then subtract the degrees of your observation from 90, and the remainder shewith the distance between your Zenith and

the Sun or Stars, which is the number you must know: unto that number so known by your instrument, add the declination of the body by which you do observe, whether it be the Sun or ante Star, and that which cometh by the addition of those two numbers together, is the Poles height, or the Latitude of the place where you are: as for Example, In the year of our Lord 1621, the third day of March, the Sun being then between my Zenith and the Equinoctial, I observed the Suns Meridional altitude from the Horizon to be 72 degrees and 20 minutes, but because I must know the distance of the Sun from my Zenith, I therefore subtract 72 degrees 20 minutes from 90 degrees, and there remaineth 17 degrees 40 minutes, the distance of the Sun from my Zenith, to that distance I add the Suns declination for that day, which by my Regiment I find to be 43 minutes 2 degrees of South declination, and it amounteth unto 20 degrees 23 minutes, so much is the South Pole above the Horizon, and so much is my Zenith South from the Equinoctial, because the Sun having South declination, and being between me and the Equinoctial, therefore the necessity the Antarctick Pole must be above my Horizon.

89 -- 60 -- the distance between the Zenith and the Horizon.

72 -- 20 -- the Suns Altitude.

17 -- 40 -- the Suns degree from the Zenith.

2 -- 43 -- the Suns Declination.

20 -- 23 -- the Poles height.

When the Equinoctial is between your Zenith and the Sun or Stars
the Altitude is thus found in all places.

By your Instrument, as before is taught, you must subtract the Meridional distance of the Sun or Stars from your Zenith: which being known, subtract the Declination of the Sun or Stars from the said distance, & the remaining number is the Poles height, or latitude which you seek: Example.

The 20 of October 1625. I find by my Instrument that the Sun is 60 deg. 45 minutes from my Zenith at Noon, being then upon the Meridian, the Equator being then between my Zenith and the Sun: I also find by my Regiment that at that time the Sun had 13 deg. 57 min. of South Declination, because the Equinoctial is between me and the Sun, therefore I subtract the Suns declination from the observed distance, and there resteth 46 deg. 48 min. the latitude desired: and because the Sun hath the South declination, and the Equinoctial, being between me and the Sun, therefore I may conclude that the Pole Artick is 46 deg. 48 min. above my Horizon so that my Zenith is so much toward the North from the Equator.

d m

60 -- 45 -- the Suns distance.

13 -- 57 -- the declination.

46 -- 48 -- the latitude.

When your Zenith is between the Sun or Stars and the Equinoctial,
the Latitude is thus found.

By your Instrument, as in the first example is shewed, you must observe the Meridional distance, of the Sun or Stars from your Zenith: you must also by your Regimient or other Tables search to know the Declination of that body which you observe, then subtract the observed distance from your Zenith out of the Declination, and the remaining number is the Latitude desired: Example. The Sun having 20 deg. of North declination, and being upon the Meridian is 5 deg. 9 min. from my Zenith, I therefore subtract 5 deg. 9 min from 20 deg. and there resteth 14 deg. 51 min. the Latitude desired: and because the Sun hath North Declination, my Zenith being between the Sun and the Equinoctial, therefore I conclude. That the North Pole is 14 deg. 51 min. above my Horizon.

d m

19 -- 60 -- the Declination.

5 -- 9 -- the Suns distance from my Zenith

14 -- 51 -- the Poles height.

How shall I know the true order of placing the Cross-Staff to mine eye, to avoid error in my observation ?

To find the true placing of the Staff at your Eye, thereby to amend the Parallax, or false shadow of your ____ do thus: Take a staff having two crosses, a long Crosse which endith in 30 degrees, and a short Cross which beginneth at 30 degrees where the long Cross endeth, put the long Cross upon his 30 degrees, and there make him fast: then put the short cross likewise upon his 30 degrees, there fasten him without moving: then set the end of your staff to your Eye, moving it from place to place about your Eye, until at one instant you may see the end of both Crosses, which when you find, remember that place and toe standing of your body, for so must your Staff be placed, and your Body ordered in all your Observations.

*

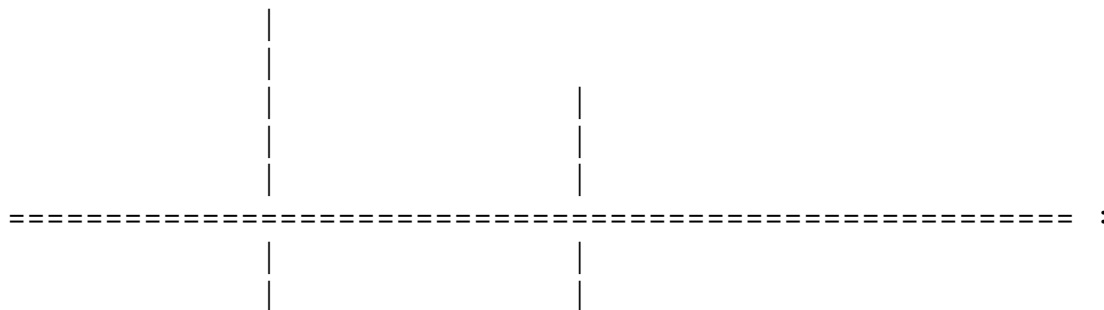

○

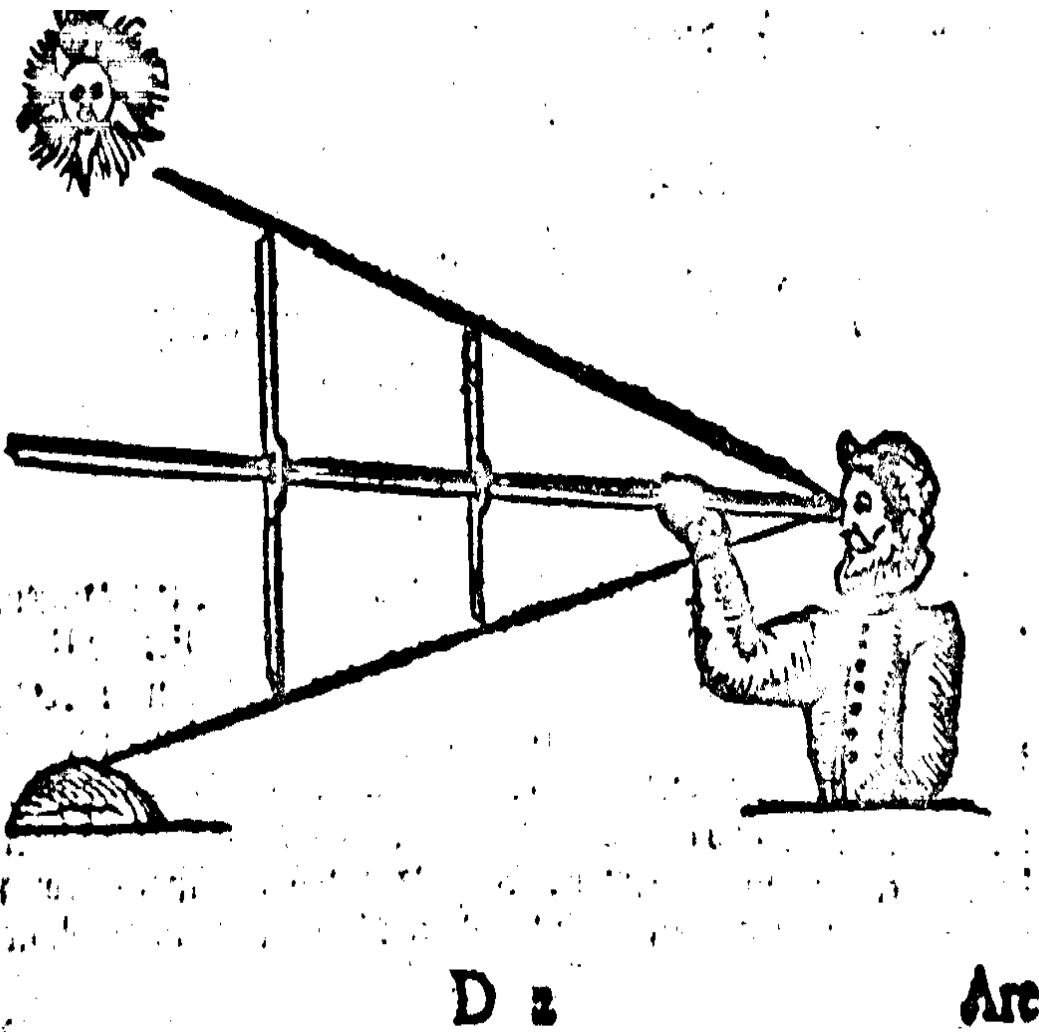

Are

Are these all the Rules that appertain to the finding
of the Poles height ?

Those that Travel far towards the North, under whose Horizon
the Sun setteth not, shall sometime have occasion to seek the Lati-
tude by the Sun, when the Sun is North from them, the Pole being
then between the Sun and their Zenith. When such observations are
made, you must by your Instrument seek the Suns height from the
Horizon, subtract that height from his Declination, and the remain-

ing number sheweth how far the Equinoctial is under the Horizon upon the point North for so much is the opposite part of the Equator above the Horizon upon the point South, subtract that Meridian Latitude of the Equinoctial from 90, and the remaining number is the Poles height desired: Example.

The Sun having 22 degrees of North declination, his Altitude from the Horizon is observed to be 3 deg. 15 min. therefore subtracting 3 deg. 15 min. from 22 degrees, there rest 18 deg. 45 min. which is the distance of the Equinoctial from the Horizon, which being taken from 90, there resteth 71 deg. 15 min. the Poles elevation desired.

d m
 21 -- 60 -- the Suns Declinations.
 3 -- 15 -- the Suns Altitude.
 18 -- 45 -- the Altitude of the Equinoctial.
 89 -- 60 -- the distance between the Zenith and Horizon.
 18 -- 45 -- the Altitude of the Equator.

 71 -- 15 -- the Altitude of the Pole.

But you must know, That the Declination found in your Regiment is not the Declination which in this case you must use: for the Regiment sheweth the Suns Declination upon the Meridian or South point, in the place for whose Meridian the same was calculated, and not otherwise: Therefore it is necessary to know the Suns Declination at all times, and upon every point of the Compass: for I have been constrained in my Northwest Voyages, being within the Frozen Zone, to search the Latitude by the Sun, at such time as I could see the Sun, upon what point of the Compass soever, by reason of the Fogs and Mists that those Northern parts are subject unto: And there is consideration also to be had upon every difference of Longitude for the Suns Declination, as I have by my experience found at my being in the Straits of Magilane, where I have found the Suns Declination to differ from my Regiment calculated for London, by so much as the Sun declineth in 5 hours, for so much is the difference between the Meridian of London, and the Meridian of Cape Froward, being in the midst of the said Straits.

+++++

How may this Declination be found for all times, and upon all points of the Compass.

First, Consider whether the Sun be comming towards the Equinoctial, or going from him: That being known, consider the time wherein you seek the Declination, then look for the Suns Declination in your Regiment for that day, and also seek his Declination for the

next day, subtract the lessor out of the greater, and the remainder is the whole declination which the Sun declineth in 24 hours, or in his moving through all points of the Compass, from which number you may by the Rule of Proportion find his Declination upon every point of the Compass for every hour of the day, as by these Examples may appear:

Examples.

In the year 1625, the 20 of March, I desire to know the Suns Declination when he is upon the North part of the Meridian of London, I seek the Suns Declination for that day, and find it to be 3 deg. 59 min. the Sun then going from the Equator. I also search his Declination for the next day, being the 21 day of March, and find it to be 4 deg. 22 min. I then subtract 3 degrees 59 minutes from 4 degrees 22 * minutes, and there resteth 23 minutes so much the Sun doth decline in 24 hours, or in going through all the points of the Compass. Then I say by the rule of Proportion, if 24 hours give 23 minutes of Declination, what will 12 hours give, &c. I Multiply and Divide, and find it to be 11 min. 30 sec. the Suns Declination in 12 hours motion to be added to the Declination of the 20 day being the Suns going from the Equator: Or for the points of the Compass, I may say, if 32 points give 22 min. of Declination, what will 16 points give,

 * textual variation, seems to be 12 in the 1657 version

which is the distance between South and North: I Multiply and Divide as the rule of Proportion requireth, and find that 16 points give 11 min. the Suns Declination in moving through 16 points of the Compass, which is to be added to the Declination of the 20 day, because the Sun goeth from the Equator, so I conclude the Declination to be 3 deg. 52 min. the Sun being North the 20 of March.

In this work the 30 seconds are omitted.

ho. mo. ho.
 24 -- 23 -- 12 -- 11
 12

 44 x
 22 xxx (11
 ---- xxx
 264 x

po. m. po. m.

or the latitude of your being: into the consideration whereof because the young practiser may the better enter, I thinke it not amisse by a few examplesto express the necessary use thereof.

1. Q. The Sun being 7 deg. of North Declination and the Pole Articke being 45 deg. above the Horizon, I demand what will be the Suns Meridional distancefrom my Zenith.

1. A. First I turne the Horizon until I bring the North Pole to be 45 deg. above the same, there holding the Horizon not to be moved. I then bring the third* that is falted* to the Center of the Instrument, 7 degrees from the Equinoctial towards the North, because the Sun

* = word that is unclear in both versions.

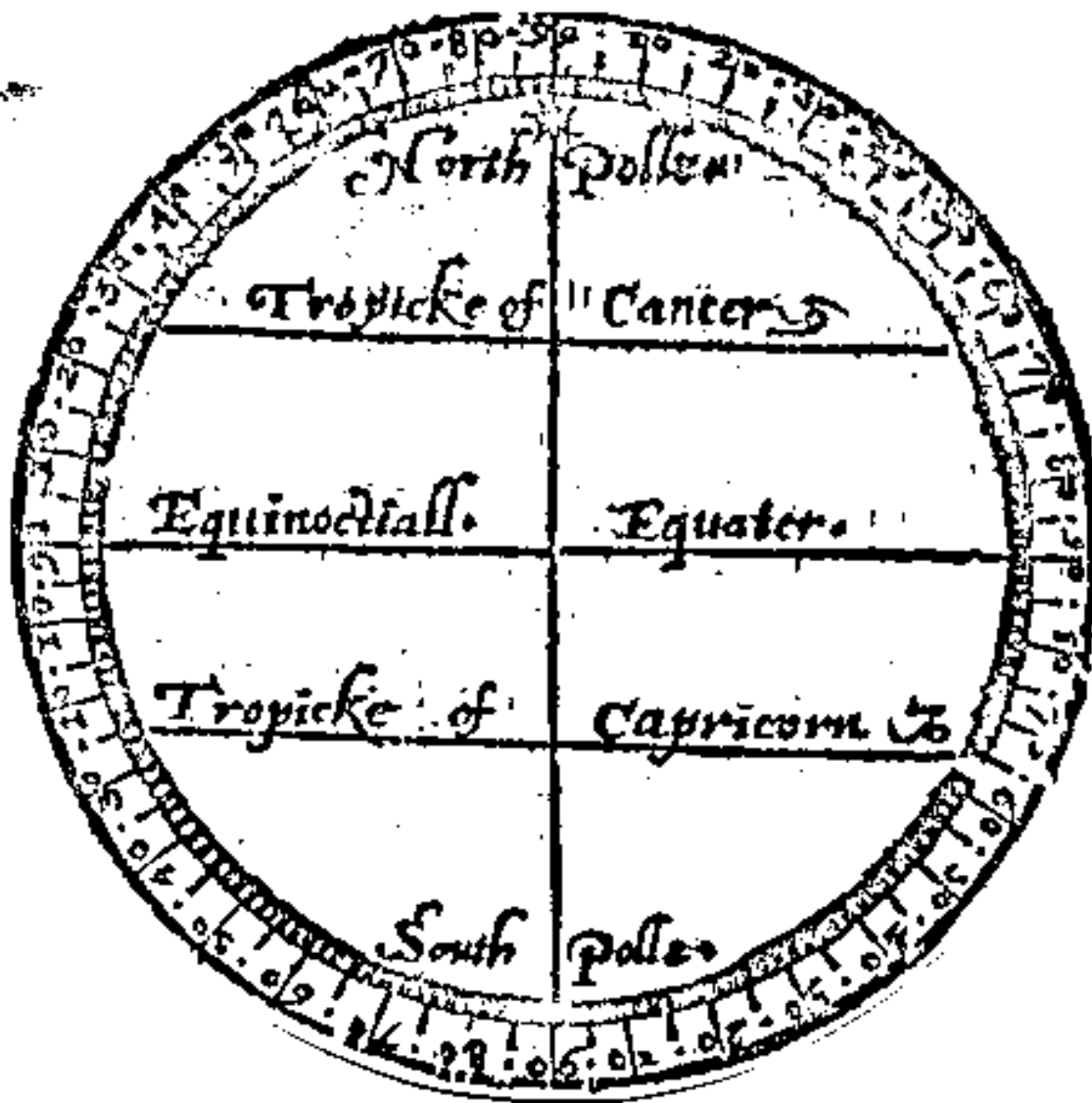

hath so much North Declination, and the third* both shew me upon the vertical Circle, that the Sun is 38 deg. from the Zenith.

2. Q. The Pole Artick being 50 deg. above the Horizon, and the Suns distance 30 deg. from the Zenith, I demand what is the Suns Declination ?

2. A. As in the first question I place the North Pole 5 deg. above the Horizon, there holding the Horizon not to be moved, then I bring the third* to the 30. deg. upon the vertical Circle, because the Sun is 30 deg. from my Zenith, and the third* sheweth upon the Meridian between the Tropick of Cancer and the Equinoctical, that the Sun hath 20 degrees of North Declination.

3. Q. The Sun having 10 deg. of South Declination, being upon the Meridian, is 53 deg. from my Zenith, I demand what is the Poles height ?

3. A. In the first question the Precise height and the Suns declination are given for the finding the Suns meridional distance from the Zenith, In the second the Poles height is given, and the Suns meridional distance from the Zenith, thereby to find the Suns declination, And in this question the Suns declination and meridionall distance, is given for the finding of the Poles height. I therefore bring the third* fa__ned in the Center of the Instrument 10 degrees South from the Equator, between the Equinoctiall and the Tropicke of Capricorne, there holding the third not to be moved, I then turne to the Horizon, untill I bring the 53 degree of the vertical circle under the third, and then the Horizon seweth me, that the North Pole is 43 degrees above the same.

4. Q. The Sun having 12 degrees of South declination, and being upon the Meridian South from me, is 30 degrees above the Horizon. I demend how far the Sun is from my Zenith, how much the Equinoctall is above the Horizon, and what is the Poles Height ?

4. A. First, I bring the third to the place of the Suns declination, as before, there holding in not to be moved, then I turn the Horizon untill I bring it to be 30 deg. under the third, and then the third sheweth me that the Sun is 60 deg. from my Zenith, and the Horizon sheweth that the Equinoctial is 42 deg. above the Horizon; although these questions are so very easie and plain, as that they may readily be ansered by memorie, yet because the reasons how they are answered may the better appeare, is the cause wherefore they are demanded, and in this sort answered, only for the benefit of such as are not altogether expert in these practices, that thereby they might likewise frame unto themselves questions of other variety, and so gather thereby the more sufficient judgement in this part of Navigation.

The rule of the Regiment (1643)

For as much as the Poles height cannot be observed by the Sunne, unlesse the Sunnes true declination bee knowne, I have therefore carefully calculated these Tables or Regiment, out of Origanus, for the yeares 1625, 6.7.and 8. which will serve untill the yeere 1644. without further correction: and because there may grow no error by mistaking the yeares, I have over every Moneth written the yeare of the Lord, in which the declination of the same Moneth is to be used, therefore when in any yeare and Moneth you seeke the Sunnes declination, first looke for the moneth, and there you shall finde 4. of those Moneths, which are the Moneths between the leape yeares, then looke over each of those moneths, untill you find the yeare of the Lord, wherein you seeke the declination, and directly under that year is the Moneth wherein you must seeke the Suns declination: Example 1626. the tenth day of Feb. I would know the Suns declination, first I seeke out February, & under the second yeare I see the yeare 1626, therefore this is my Moneth, against the tenth day of which Moneth I find that the Sun hath 10 deg. 49 min of South declination, and after the like manner you must do in all the rest as occasion requireth.

(In the 1643 edition there follows 12 pages of tables, 4 columes per page.)

* titled "The use of the Regiment" in the 1643 version

The text is much different in the earlier version, as you see.

What is the Chart ?

The Sea Chart is a speciall instrument for the Seamans use whereby the Hydrographicall description of the Ocean Seas, with the answering Geogrphical limits of the earth, are supposed to be in such sort given, as the longitudes and latitudes of all places, with the true distance and course be between place and place, might be truly known. But because there is no proportionable agreement between a Globus superficies*, and a plaine superficies*, therefore a Chart both not expresse that certainty of the premises which is thereby pretended to be given, for things are best described upon bodies agreeable to their own form. And whereas in the true nature of the Sphere, there can be no Parallels described but the East and West courses only, the rest of the courses being concurred lines, ascendent toward the Poles, the Meridians all concurring and joyning together in the Poles, notwithstanding in the Sea Chart all the those courses are describ- ed as Parallels, without any diversity, alteration, or distinction to the contraty, whereby the Instrument is apparently faulty: yet it cannot be denied, but Charts for those courses are to very good purpose for the Pilots use, and in long courses, be the distance never too far, if the Pilot return by the same course, whereby in the first he prosecuted his voyage his Chart will be without error, as an Instrument of very great commodity, but if he return by any other way, then by that which he went forth, the imperfections of the Chart will then appear to be very great; especially, if the voyage be long, or the

same be in the North parts of the world, the farther toward the North, the more imperfect: therefore there is no Instrument answerable to the Globe, or paradoxall Chart, for all courses and climates whatsoever, by whom all declared truth is most plentifully manifested, as shall hereafter at large be declared, but for the coasting of any those, or Country, or for short voyages, there is no Instrument more convenient for the Seamans use, then the well described Sea Chart.

What is the use of the Sea Chart.

By the directions of the Sea Chart the skillful Pilot conveyeth his ship from place to place, by such courses as by the Chart are more known to him, together with the help of his Compass, or Crosse Staff, as before is shewed, for the Cross-Staff, the Compass, and the Chart, are so necessarily joynd together, as that the one may not well be without the other, in the execution of the practices of Navigation: for as the Chart shewith the courses, so both the Compass direct the same, and the Crosse-Staff by every particular observed latitude both confirme the truth of such courses, and also give the certaine distance that the Ship hath sayled upon the same.

* the modern term is probably "surface"

And in the use, or understanding of the Sea Chart, there are five things chiefly to be regarded.

The first is, that Countries, or Geography of the Chart be known, with every Cape, Promontory, Port, Haven, Bay, Sands, Roks, and dangers therein contained.

Secondly, that the lines drawn upon the Chart, with their several properties be likewise understood.

Thirdly, that the latitude of such places as are within the Chart; be also known, as by the Chart they are expressed.

Fourthly, that you be able to measure the distance between place and place upon the Chart.

And fiftly, the Seaman must be able by his Chart, to know the true courses between any Iles, Continents, or Capes whatsoever: for by these five diversities, the Chart is to be used in the skil of Navigation.

How is the latitude of places knowne by the Chart.

The latitude is thus found by the Chart, upon the place, whose latitude you desire to know, set one foot of your Compasses, then stretch the other foot to the next East and West line (for that line is your Director) keeping that foot still upon the same line, move your hand and Compasses East, or West, as occasion requireth, untill you bring the Compasses to the graduated Meridian, and there that foot of the Compasses which stood upon the place, whose latitude you would know, both shew the latitude of the same place.

How is the course between place and place knowne ?

When there are two places assigned, the course between which you desire to know, set one foot of your Compasses upon of the places, then by discretion consider the lines that lead toward the other place, stretching the foot of the Compasses to one of those lines, and to that part of the line which is nearest to you, keeping that foot still upon the same line, move your hand and Compasses toward the other place, and see whether the other foot of the Compasses that stood upon the other place, doe by this direction touch the second place, which if it doe, then that line whereupon you kept the one foot of your Compasses, is the course between those places: if it touch not the place, you must by discretion search untill you finde a line, whereupon keeping the one foot of the Compasses, will lead the other foot directly from the one place to the other, for that is the course between those two places.

How is the distance of places found upon the Chart ?

If the places be not farre asunder, stretch a paire of Compasses between them, setting the one foot of the Compasses upon one of the places, and the other upon the other place, then not altering the Com-

(here are contained 6 pages of Tables before the text continues)

(Nov, Dec, Sept, Oct. July, Aug.)

passes, set them upon the graduated Meridian of your Chart, and allowing 20 leagues for every degree that is contained between the two feet of your Compasses, the distance desired is thereby known: if between the places there be 5 degrees, then they are 100 leagues asunder, &c. But if the distance between the places be so great as that the Compasses cannot reach between them, then take out 5 degrees with your Compasses, which is 100 leagues, & therewith you may measure the distance as practice will teach you. There is also in every Chart a scale of leagues laid down, whereby you may measure distances, as is commonly used.

How doth the Pilot order these matters, thereby to conduct his
Ship from place to place ?

The Pilot in execution of this part of Navigation, doth with careful regard, consider three especial things, wherupon the full practises are grounded.

1. Of which the first is, the good observation of his latitude, which how it may be knowne is before sufficiently expended.
2. The second is a carefull regard of his steredge, with diligent examination of the truth of his Compasse, that it be without variation or other impediments.
3. And the third is a carefull consideration of the number of leagues, that the Ship sayleth in every hour or watch, to the neerest estimation that possibly he can give, for any two th these three practices being truly given, the third is thereby likewise knowne.

As by the Corse and height the distance is manifested, by the distance and Crose the height is knowne: by the height and distance the Corse is given, of which three things the Pilot hath only his height in certain:

the Corse is somewhat doubtfull, and the distance is but barely supposed, notwithstanding from his altitude and Corse he concludeth the truth of his practise, proceeding in his sort.

First, he considereth in what latitude the place standeth from whence he shapeth his Corse, which for an example shall be the Lysart Standing* in 50 degrees of Septentrional latitude, then directing his Corse S.W. sayleth 3 or 4 daies or longer in such thick weather, as that he is not able

to make any observation of the Poles altitude, in which time he omiteth not to kep an axxompt how many leagues the Ship hath sailed upon that Corse as neer as he can gesse, which number of leagues in this example shall be 100 according to his judgement: then having convenient weather, he observeth in what latitude he is, and findeth himself to be in 47 degrees, now with his Compasses he taketh the distance of 100 leagues, which is the quantity of the Ships run by his supposition, and then setting one foot of the Compasses upon the Lysart, which is the place from whence he began his Corse, and directly South West from the same he setteth the other point of the Compasses, by the direction of another pair of Compasses, in such sort as Corses are found, and there he maketh a prick for the place of his Ships being, according to his reckoning and Corse.

And now searching whether it do agree with his height, (for the right, Corse, and distance must also agree together) he findeth that his prick standeth in 46 degrees, 26 minutes, but it should stand in 47 degrees to agree with his observation. Therefore perceiving that he hath given the Ship too much way, he bringeth his Corse and observed altitude to agree and then he seeth that his ship hath sailed but 85 leagues, and there he layeth down a prick for the true place of his ships being, according to his Corse and latitude, for so by his Corse and height he findeth the truth of his distance, and reproveth his supposed accompt to the 15 leagues too much: and after this sort he proceedeth from place to place, until he arrive unto his desired Port: which is a conclusion infallible, if there be no other impediments, (whereof there hath not being good consideration had) which msy breed error, for from such negligence there may arise many inconveniences.

What may those impediments be ?

By experience at the Sea we find many impediments that so disturb the expected conclusion of our practice, as that they agree not with the true positions of Art. For, First it is a matter not common to have the wind so beneficial as that a Ship may sail therby, between any 2 assigned places upon the direct corse, but that by the contrariety of winds, she may be constrained to travers upon all points of the Compass, the nature whereof I have before sufficiently expressed.

Secondly, Although the wind may be in some sort favour, yet the ship may have such a Leeward condition, as that she may make her way 2 or 3 points from her caping.

Thirdly, The Sterage may be so disorderly handled, as that thereby the Pilot may be abused.

And lastly, The Compass may be so varied, as that the Pilot may likewise thereby be drawn into error, at all which things, and many moe, as the nature of his Sayling, whether before the wind, quartering, or by a bowling, or whether with lofty or low sails, with the benefits or hinderances of the Sea, tydegates, streams, and forced let therefore, &c. of all which things (I say) the skilful Pilot must have careful consideration, which are better learned by practice, than taught by pen, for it is not possible that any man can be a good and sufficient Pilot or skilful Seaman, but by painful and diligent practice, with the assistance of Art, whereby the famous Pilot may be esteemed worthy of his Profession as a Member meet for the Common weale.

And now having sufficiently shewed you the ordering of your Chart, for the execution of the skill of Navigation, and being also desirous that you should effectually understand the full nature & use of the same: I think it good by a few questions to give you an occasion to exercise yourself, in the perfect accomplishment of such conclusions as are by this excellent and commodious instrument to be performed.

Necessary Questions for the better understanding of the
commodious use of the Chart.

1. Q. If I sail 70 leagues upon the Southwest course, I demand how many degrees I shall lay or depress the Pole ?
A. The difference will be 2 degrees, 30 minutes.
2. Q. If in sayling West Northwest I raise the Pole 3 degrees, 30 minutes, I demand how many leagues I have sailed ?
A. The distance sailed is 180 leagues.
3. Q. If in sayling 180 leagues between West and North, I raise the Pole 3 degrees, I demand upon what course I have sayled, and how far I am from the Meridian from whence I began that course ?
A. The Corse sailed is Northweat by West, and the distance from the Meridian is 90 leagues.
4. Q. If in sayling 154 leagues I be 80 leagues West from the Meridian from whence I began my Corse, I demand upon what point of the Compass I have sailed, and how much I have raised the Pole ?
A. The Corse is Northweat by North, and the Pole is raised 6 degrees.
5. Q. If I sail Northwest until I be 50 leagues from the Meridian, where I began my Corse: I demand how many leagues I have sailed, and how much the Pole is raised ?
A. The distance sailed is 71 leagues, and the Pole is raised 2 degrees, 32 minutes.
6. Q. If in sayling W.N.W. I do in 30 hours raise 2 degrees, how many degrees should I have raised the Pole if the same motion had been North and by West ?
A. You should have raised 5 degrees.

7. Q. A Ship sayling towards the West, for every 80 leagues that she sayleth in her Corse, she departeth from the Meridian from whence she began the same Corse 45 leagues, I demand upon what point of the Compass, and how many leagues she hath sayled, in raising the Pole 5 degrees ?

A. She hath sayled Northwest by North 120 leagues.

8. Q. A Pilot sayling toward the West 100 leagues, hath forgotten his Corse, yet thus he knoweth that if he had sayled upon such a corse, as that in 160 leagues sayling he would have raised the Pole 3 degrees, he should then have been twice as far from the Meridian as now he is, and should also have 1/2 degrees further to the Northward then he now is, I would now know what corse he hath sayled, how many leagues, and how far he is separated from the Meridian, from whence he began the said corse ?

8. A. She hath sayled 88 leagues Northwest by West, & is 73 leagues from the Meridian nearest.

9. Q. Two ships departing from one place, the one sayling 145 leagues toward the west, hath raised the Pole 4 degrees, and the other hath the Pole 7 degrees, and is 95 leagues West from the Meridian of the place from whence he began his corse, I demand by what corse the said ship hath sayled, and how far they be asunder, and by what corse may they meet ?

A. The first ship hath sayled Northwest by west, the second hath sayled Northwest by North 170 leagues, they are asunder 65 leagues, and the corse between them is North northeast, and South southwest.

10.Q. Two ships sayling from one place, the one in sayling 180 leagues, is to the Eastward of the Meridian where he began his corse 150 leagues, I demand upon what corse, & how many leagues the other ship shal sayl, to bring himself 50 leagues N. by W. from the first Ship ?

A. The first ship hath sayled N.E. by E. and hath raised the Pole 5 degrees, the second ship must sayle Northeast by North 237 leagues.

A

lthough it may seem (to some that every expert in Navigation) that these Questions are needlesse, and without use, being so plain as not deserving in this sort to be published, notwithstanding that their Opinion, I do in friendly courtesie advise all young Practi-

sers of this excellent Art of Sayling, that they do not only by their

Charts prove the truth of these answerd Questions, but also endeavor themselves to propound divers others sorts of Questions, and in seeking their Answers to enter into the Reason thereof: for by such exercise, the young beginner shall understand the substantial grounds of his Chart, and grow perfect therein: for whose ease and furtherance only, I have at this present Published this brief Treatise of Navigation, knowing that the expert Pilot is not unfurnished of these Principles, but every little help doth greatly further in every beginning: And therefore for the further benefit of the Practicer, I have hereunto annexed a particular Sea Chart of our Channel, commonly called the Sleeve, by which all that is before spoken as touching the use of the Chart, may be practiced, wherein the depths of the Channel are truly laid down: being an Instrument most commodious and necessary for such as seek the Channel.

nel comming out of the Ocean Sea, much of it is from my own practice, the rest from Pilots of very good sufficiency & I have found great certainty by the use of this Chart, for by the Altitude and depth I have not at no time missed the true notice of my Ships being, which (through Gods merciful favour) by my lands falls I have found always to be without terrour, therefore have it not in light regard, for it will give you great evidence, and is worthy to be kept as a special jewel for the Seamans use, be he never so expert.

And thus having sufficiently expressed all the practices appertaining to the skill of Horizontal Navigation, which kind of Sayling is now of the greatest sort only practised; I think it good for your better memory, briefly to report that which before is spoken as touching this kind of Navigation, and withal it will not be amisse to shew you after what sort I have been accustomed to keep my Accompts in my practises of Sayling, which you shall find to be very sure, plain, and easie, whereby you may at all times examine what is past, and to reform the causes laid down upon the Chart, if by chance there should be any error be committed. And so concluding this part of Navigation, will in the next Treatise make known unto you the use of the Globe, such uses I mean as Seaman may practice in his Voyages, and that are most necessary for his knowledge.

+++++

A Table

+++++

A Table shewing the Order how the Seamen may keep his Accompts, whereby he may at all times distinctly examine his former practises, for in every 24 hours, which is from noon to noon, he doth not only lay down his Latitude, which the Corse and Leagues, but also how the Wind hath blown in the same time.

The first Columbe is the months and dayes of the same; the seonc is the observed Altitude, the third is the Horizontal Corse or motion of the Ship, the fourth the number of Leagues that the Ship hath sayled, the fifth is a space wherein must be noted, by what Wind those things have been performed: and the next great space is to lay down any brief Discourse for your memory.

ANNO 1593							The 13 of March cape S Augujiiu in Brasil, being 16 leagues East from me, I began this accompt.
Month and dayes of the Month.	Longi- tude G. M.	Corse.	Leag- us	Wind			
March. 24	7 30	N.N.E.	25	East			
25	5 44	N.b E.nor	30	E.b.N	Compass varied 9 degrees the South		
26	4 1	N.b.N.	35	E.b.N	point windward		
27	2 49	N.	24	E.b.N	Compass variat 8 degrees, the South points windward.		
28	1 31	N.easterly	26	E.b.N.			
29	1 4	N.N.W.	9	N.E.			
Aprill. 31	0 0	N.b.W.	21	E.N.E.	Compass varied 6. deg. 40.min. the South point west- ward.		
4	0 39	N.W.b.N	15	N.E.			
7	1 53	N.N.W.	28	N.E.	Observation, the Pole Artick above the Horizon.		
9	3 5	N.W.b.N	20	N.e.b.E			
10	4 5	N.W.b.N.	22	N.e.			
11	4 45	N.W.	18	N.e.b.N			
12	5 16	N.W.	14	N.e.b.N	Compass varied 9. degrees, the North point Eastward.		
13	6 11	N.W.b.N.	23	N.e.			
14	7 16	N.W.b.N.	24	N.e.			

A brief

A brief Repetition of which is before spoken.

There are three kinds of Navigation, Horizontle, Paraboral, and Saylor upon a great Circle, performed by the Corse and Traverses. A Corse is the paraboral line, which is described by the Ships motion upon any point of the Compass.

A Travers is the variety of the Ships motion upon & very alteration of Courses.

The Compass is an artificial Horizon, by which Courses and Traverses are directed, and containeth 12 points, and a very point containeth $11 \frac{1}{4}$ degrees. or 45 minutes, being $\frac{1}{4}$ of an hour.

By such quantity of time as the Moon separateth her self from the Sun, be the like rate of time every tide both one differ from another. In every hour the tyde altereth two minutes, in every flood 12 min. and in every ebbe 12 min. and in every day 48 minutes, because that so is the Moons separation from the Sun: for the Moon doth separate her self from the Sun, in every day one point and 3 minutes, between the Change and the Full she is to the Eastwards of the Sun, and then is her separation, at which time she is before the in respect of her natural motion but in regard of her violent motion, she is then behind or abaft the Sun.

Between the Full & Change, she is to the Westward of the Sun, applying towards the Sun, and then is her application, at which time she is behind or abaft the Sun, in respect of her natural motion, but in consideration of her violent motion, she is then before the Sun.

She hath a violent motion, a natural motion, a slow, swift, and mean motion.

In every 27 degrees and 8 hours, she performeth her natural motion through the Zodiack.

Between Change and Change there is 29 days, 12 hours, 44 minutes nearest.

The Solar year consisteth of 12 months, and the Lunar year of 12 Moons.

The Moons Age is found by the Epact.

All Instruments used in Navigation, of what shape or form soever they be, are described or demonstrated upon a Circle, or some portion of a circle, and therefore are of the nature of a Circle.

A Degree is the 360 part of a Circle, how big or little soever the Circle be.

A Degree is applied after the 6 several sorts, to the Equator, to the Meridian, to the Horizon, to the vertical Circle, to Measure, to Time.

Altitude is the distance, height, or mounting of one thing above another.

The Poles Altitude is the distance between the Pole and the Horizon, or the position of the Meridian which is contained between the Pole and Horizon.

The Altitude of the Sun above the Horizon, is that portion of the vertical circle, which is contained between the Horizon and the Sun.

Latitude, is that arc of Meridian which is contained between the Parallel of any place and the Equator, or that part of the Meridian which is included between the Zenith and the Equinoctial.

Longitude is that portion of the Equator contained between the Meridian of S. Mihels, one of the Iles of the Assores* and the Meridian of the place whose longitude is desired: the reason why the accompt of the longitude both begin at this Ile, is because that there the Compass hath no variety, for the Meridian of this Ile passeth by the poles of the world, & the poles of the Magnet, being a meridian proper to both poles. **

The Longitude between place and place, is the portion of the Equator, which is contained between the Meridian of the same places.

Declination is the distance of the Sun, Moon, and Stars, from the Equinoctial, or that part of the Meridian which passeth by the Center of any celestial body, and is contained between the same center and the Equinoctial.

Hydrography is the description of the Ocean Sea, with all Iles, Bancks, Rocks, and Sands therein contained, whose limits extend to the Geographical borders of the earth, ther perfect notice whereof is the chiefest thing required in a sufficient Pilot, in his excellent practice of Sayling.

Geography is the description of the earth only, whereby the terrestrial form in his due situation is given, whose distinction is by mountains, rivers, vallies, cities, and places of fame, without regard of Circles, Climates, and Zones.

Cosmography is the description of the Heavens, with all that is contained within the circuit of but to the purpose of Navigation, we must understand Cosmography to be the universal description of the terrestrial Globe, distinguished by all such circles, by which the distinction of the celestial Sphere is understood to be given, with every Country, Coast, Sea, Harborow, or other place seated in their due longitude, latitude, zone, and clyme.

The Chart is a special Instrument in Navigation, pretending the Cosmographical description of the terrestrial Globe, by all such lines, circles, corses, and divisions as are required to the most exquisite skill of Navigation.

+++++

The End of the First Book.

NOTES

* Assores = Azores Islands

** There was a time when it was thought one could find longitude from magnetic variation.

[Click Here](#) for the **Second Book** - or part 2 - of **Seamans Secrets**.

[Click Here](#) to go to the introductory material..



中華人民共和國香港特別行政區政府
The Government of the Hong Kong Special Administrative Region
of the People's Republic of China

ENGLISH | 繁體版 | 簡體版 |



Navigation in the Information Age:

An Exploration of the Potential Use of Geographic Information Systems (GIS) for Sustainability and Self-Determination in Hawai`i

A Thesis in Social and Cultural Anthropology Presented to the Faculty of the
California Institute of Integral Studies

In Partial Fulfillment of the Requirements for the Degree of Master of Arts

Christopher Cogswell
and
Ulrik Schiøtz

June 21, 1996

[Abstract](#)

[Table of Contents](#)

ALOHA!



HAWAII

Independent & Sovereign

"The cause of Hawaii and independence is larger and dearer than the life of any man connected with it. Love of country is deep-seated in the breast of every Hawaiian, whatever his station."

- Lili'uokalani, Hawaii's last Queen

"This is a historical issue, based on a relationship between an independent government and the United States of America, and what has happened since and the steps that we need to take to make things right."

- Republican Governor Linda Lingle, January 2003

"The recovery of Hawaiian self-determination is not only an issue for Hawaii, but for America. ... let all of us, Hawaiian and non-Hawaiian, work toward a common goal. Let us resolve ... to advance a plan for Hawaiian sovereignty."

- Democratic Governor Ben Cayetano

[1998 State of the State Address](#)

Explore the [legal foundation](#) for Hawaii's independence.

Check out the [latest news and alerts](#) posted to our [email list](#).

Visit [Hawaiian Independence Weblog](#) for daily news and commentary.

On January 13th, 2004, the Nation of Hawaii began the FIRST PHASE of a Campaign to Educate Tourists regarding the ILLEGAL, CIVIL and MILITARY OCCUPATION of HAWAII.

When: Every Wednesday @ 10 a.m.

Where: Duke Kahanamoku Statue

Contact: Bumpy Kanahale at 808-259-9018





"Ua Mau Ke Ea O Ka `Aina I Ka Pono" 

The Life/Sovereignty of the Land is Perpetuated in Righteousness

SUBSCRIBE

to our news, update, and action alert mailing list.

SEARCH THIS SITE

See the [Awards](#) which have honored this site

Support this Website
[Order Hawaiian Books Online!](#)
Sovereignty, Politics & History



MAIN FEATURE AREAS:

- o [Overview](#)
- o [Legal Foundation](#)
- o [News Archive](#)
- o [Historical Information](#)
- o [Policy Statements](#)
- o [Images](#)
- o [Books - Order Online](#)
- o [Music](#)
- o [Support Hawaiian Self-Determination](#)
- o [Contact Information](#)

- o [Hawaiian Sovereignty and Culture LINKS](#)

Articles and Events

The links below provide highlights of current and past activities related to Hawaii's independence and history. They are collected from a variety of sources, in order to support education, awareness and action, with aloha.

New website:
Hawaiian Society of Law and Politics (HSLP)

OHA trying to eliminate options
Commentary by Anne Keala Kelly
Honolulu Advertiser, Sunday, January 18, 2004

Hawaiians hand out sovereignty leaflets in Waikiki
Honolulu Star-Bulletin, Wednesday, January 14,
2004

New website: CNHA Exposed
The real agenda behind the
Council for Native Hawaiian Advancement

School lets non-Hawaiian stay
In exchange, the student will drop his suit against
Kamehameha Schools
Honolulu Star-Bulletin, Saturday, November 29,
2003

Kamehameha settles Kaua'i boy's lawsuit
The Honolulu Advertiser, Saturday, November 29,
2003

Kamehameha Schools wins admissions case
The Honolulu Advertiser, Monday, November 18,
2003

Federal judge upholds Hawaiians-only school
The court rules that Kamehameha Schools'
admission policy serves a legitimate purpose
The Honolulu Star-Bulletin, Monday, November 18,
2003

Hawaiians mobilize with Honolulu march
Demonstrators parade through downtown to begin
a three-day protest
The Honolulu Star-Bulletin, Monday, November 17,
2003

Protesters demand justice for Hawaiians
The Honolulu Advertiser, Monday, November 17,
2003

Hawaiians march for independence
Associated Press, Sunday, October 19, 2003

Hawaiians march to unify a voice
Contra Costa Times, Monday, October 20, 2003

Native Hawaiians to March on US

**AKAKA BILL: Unnecessary bargain extinguishes all
claims in exchange for recognition**

Commentary by J. Kehaulani Kauanui
Honolulu Advertiser, Sunday, April 25, 2004

**Leis and Lies: Why Hawaii and Iraq are Birds of a
Feather**

The Simon, April 5, 2004

**Apology Bill 10th Anniversary raises questions
about financial promises to Hawaiians**

By Bumpy Kanahale
Honolulu Star-Bulletin, November 23, 2003

OFFICIAL NOTICE OF HUMAN RIGHTS VIOLATIONS

Served to U.S. Military, Nov. 4, 2003

Natives, Senators and Oil

The connection between drilling in the Arctic National
Wildlife Refuge and the Akaka Bill
by Anne Keala Kelly, Hawaii Island Journal, October
2003

Tropical Battle of Race, Rights Divides Islanders

Lawsuits Challenge Health Care, Housing and
Educational Services Limited to Native Hawaiians
Washington Post, Sunday, September 14, 2003

Economics of Dependent Status

Honolulu Weekly, August 27, 2003

From Native Hawaiian to Native American?

Inside the Akaka Bill, by Anne Keala Kelly
Hawai'i Island Journal, August 1-15, 2003

**Danner and Associates, Arctic Power, and the
Akaka Bill**

Native Hawaiian issues will impact business

Pacific Business News, August 4, 2003

New hopes arise for ancestral culture

By Alani Apio
Honolulu Advertiser, January 19, 2003

Sovereignty: Out of sight, not out of mind

Commentary By John Griffin
Honolulu Advertiser, Sunday, June 9, 2002

"HAWAIIAN POWER"

Displayed at Kahului Airport

Access closed for two hours, February 4, 2001

West Coast for Hawaiian Independence

PRNewswire/Yahoo News, Wednesday, October 15,
2003

Thousands join march for Hawaiian rights

Honolulu Advertiser, Monday, September 8, 2003

Rights march unifies groups

Hawaiian clubs, trusts and agencies marshal
thousands to protest threats to entitlements
Honolulu Star-Bulletin, Monday, September 8, 2003

READ AND ACT:

StopAkaka.com

News, info and lobbying resources to
oppose the "Akaka Bill" and "federal recognition"

**The Annexation Of Hawaii: A Collection of
Documents**

From UH Hamilton Library's Digital Archive
Posted May, 2003

Continuity of the Hawaiian Kingdom

Legal Opinion by Dr. Matthew Craven,
University of London Law Department
July 2002

Hawaiian Kingdom **Civil Code**
and **Penal Code** available online

**Hawaiian Kingdom Complaint filed against
United States with U.N. Security Council**

July 5, 2001

Airport protest peaceful, informative

Native Hawaiians make their point,
impression on passersby
The Maui News, February 4, 2001

Big Island Conspiracy CDs

Street Tapestry Vol. 1 "Reflective But Unrepentant"
Limited edition

**Ka Pae`aina o Hawai`i Loa
United Independence Statement**

**Hawaiian history, culture shared
at Asian Development Bank meeting**

May 2001

Paul Harvey - The Rest of the Story

"Down in the shadowy realms where U.S. foreign policy
shakes hands with the devil... the overthrow of a
friendly monarchy."

The Rosy Dawn of US Imperialism

Hawai'i, January 16, 1893
Counter Punch, January 16, 2003

Send e-mail: exec@hawaii-nation.org

www.Hawaii-Nation.org

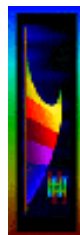

Web site design by
Ho`okele Hawai`i
HawaiiiaNavigation



This Web site sponsored in part by
The MacMouse Club: Sand, Surf, Sales & Service!

Navigation in the Information Age: **Potential Use of GIS for Sustainability and Self-Determination in Hawai`i** Cogswell and Schiøtz, 1996

[<-- 3. METHODOLOGY](#)[CONTENTS](#)[5. NATION OF HAWAII](#) --

>

[REFERENCES](#)

4.0 History and Context

In this chapter, we examine several relevant historical and contextual dimensions of this research. Through this exploration of Western maps, Hawaiian history, and GIS on a general level, we hope to lay a foundation for the reader to better understand and evaluate our ethnographic findings on these subjects in the specific context of Hawai`i, which appear in the chapter which follows.

[CONTENTS](#)[REFERENCES](#)

4.1 Western Maps and Hawai`i

This section discusses several important developments in the origin and evolution of the Western written map, and then looks at the tradition of Polynesian navigation over the same period. Through this historical and cross-cultural exploration, we hope to shed light on the dynamic relationship between culture, technology, and maps, and provide a significant foundation for the exploration of computer assisted mapping.

We begin in antiquity with the emergence and importance of geometry and the coordinate system. We then describe how the advent of perspective painting of the Renaissance, in combination with the rediscovery of the coordinate system, fostered the beginning of a new era of the "objective map," spatial definition, "the grid," and colonialization and exploitation on an unprecedented scale. From Italy we then move to the other side of the planet where Polynesians had been navigating across vast spaces without any printed map, yet with great accuracy and skill, for centuries: we consider how ocean navigation has been an integral part of Polynesian culture. With these two different knowledge systems in mind we briefly describe the impact of the European map on Hawai`i's land and culture, as Hawai`i became a point on global maps used by growing numbers of people. The "discovery" and mapping of Hawai`i were a prelude to more than two centuries of European colonization and influence whose effects have recently culminated in a Hawaiian sovereignty movement, in which the Nation of Hawai`i offers one model in a context of other sovereignty groups and models.

4.1.1 The Invention of "Space" and the Western Map

Basic to the understanding of the importance of the discoveries that underlie the scientific, neutral Western map is the notion of spatiality, which is described by Robinson:

As we experience space, and construct representations of it, we know that it will be continuous. Everything is somewhere, and no matter what other characteristics objects do not share, they always share relative location, that is, spatiality; hence the desirability of equating knowledge with space, an intellectual space. This assures an organization and a basis for predictability, which are shared by absolutely everyone. This proposition appears to be so fundamental that apparently it is simply adopted a priori. (Robinson, 1976: 4)

It was the Greek civilization that systematized the concept of space as we have come to perceive in the West. In Alexandria around 300 BC., we can originate the birth of the Western map in the concept of the coordinate system, which came to be a central element of most later mapping efforts. At this time the Greek mathematician Euclid developed the first science of space, which he called "geometry." Euclid organized space as a coherent system of straight lines, supported by terms that he postulated as immutable truths. One of these postulates, which most children in the Western educational system still repeating in their homework today, is that parallel lines will never cross. Leonard Schlain writes about Euclid, who "...organized space as if its points could be connected by an imaginary web of straight lines that in fact do not exist in nature. Geometry was an entire system based on a mental abstraction" (Schlain, 1991: 30-31).

The creation of geometry made it possible for thinkers to represent three dimensional concepts of motion, time or space on a one dimensional plane intersected by a horizontal abscissa and a vertical ordinate. This new ability to represent abstract thoughts and concepts visually on a piece of paper was the beginning of the several centuries of scientific discoveries (Schlain, 1991: 52).

Around 150 A.D., Ptolemy, who was schooled in astronomy, physics, mathematics and optics as well as geography, created what is thought to be the first map coordinate system. He showed the location of 8000 places in relation to longitude measured from a prime meridian through the Fortune Islands, and latitude measured from the equator (Whitfield, 1994: 8). But according to Turnbull, "the use of grids originated in China, probably with the work of Chang Heng in the first century A.D." (Turnbull, 1994: 26). His work has only been noted by his biographer Tshai Yung; unfortunately none of his map and grid work has survived to the present.

Over a thousand years later these discoveries were reintroduced as artists of Europe began to experiment with "perspective," which was based on fundamental principles of geometry. In 1435 Leon Battista Alberti published his thoughts on perspective, which influenced painters of the Renaissance in their attempts to represent the world with more and more "accuracy." Schlain writes about the development of this technique, which was perceived by most people of the time as enthusiastically as computer technology is today.

The beginning development of perspective by Giotto and its elaboration by Alberti and other artists was a revolutionary milestone in the history of art. By painting a scene from one stationary point of view, an artist could now arrange three axes of the geometry of space in their proper relationships. Perspective, which literally means "clear-seeing," made possible a new third dimension of depth. Using perspective to project a scene upon a two dimensional surface made the flat canvas become a window that opened upon an illusory world of stereo vision. *Literally and compositionally, art came down to earth as the horizon line became, for the renaissance artist as for the seaman exploring the globe, the most crucial orienting straight line.* (Schlain, 1991: 53; emphasis added)

It was in this context that Ptolemy reemerged and won wide recognition with the republication of his work, after more than a thousand years of obscurity. Representing the culmination of six centuries of geographical observation and theory from the Greek civilization, Ptolemy had quite an impact on European cultures at the dawn of the Renaissance. Whitfield writes about this formidable figure.

Ptolemy appeared to have cast a transparent net over the earth's surface, every strand of which was precisely measured and placed. He had defined his subject - one quarter of the earth's surface - and within a geometric framework he had calculated each element of his composition ... This sense of ordered space was precisely the ideal towards which the artists of fifteenth century Italy were striving, and this identity of interest explains Ptolemy's appeal. (Whitfield, 1994: 10)

Harley sums up the enormous impacts of the coordinate system, which even the world's most remote regions would come to experience in the years following the Renaissance.

The rediscovery of the Ptolemaic system of co-ordinate geometry in the fifteenth century was a critical cartographic event privileging a 'Euclidean syntax' which structured European territorial control. Indeed, the graphic nature of the map gave its imperial users an arbitrary power that was easily divorced from the social responsibilities and consequences of its exercise. The world would be carved up on paper. (Cosgrove, 1988: 282)

With these developments in art and physics, a new kind of consciousness was forming out of which came the Western map, with its claim to objectively describe nature, or, more generally, space itself. Just as the development of the alphabet emerged out of a context in which there was a need to keep track of, and record, excess production piled up in storage, so did the map evolve out of a certain context and need. Maps were "... a similar invention in the control of space and facilitated the geographical expansion of social systems" (Ibid: 280). Harley adds to this point when he writes, "just as the clock, as a graphic symbol of centralized political authority, brought 'time discipline' into the rhythms of ... workers, so too the lines on maps, ... introduced a dimension of 'space discipline'" (Ibid: 285).

With this newly developed understanding of spatial knowledge the European powers were equipped with a new tool for the maritime exploration of the world that facilitated an aggressive expansion of European territorial dominance. Harley writes about the development of worldwide imperialism, and its relation to the map:

The "very lines on the map exhibited this imperial power and process because they had been imposed on the continent with little reference to indigenous peoples, and indeed many places with little reference to the land itself. The invaders parceled the continent among themselves in designs reflective of their own complex rivalries and relative power. (Ibid: 282)

As the European maritime powers were moving further and further away from their home territory, their navigational skills were increasing. However, it was not until the second half of the eighteenth century that navigational practices included all the necessary tools such as the sextant, lunar position and distance, star charts etc., to locate a point in relation to the two lines of latitude and longitude. These tools enabled European explorers to navigate through uncharted oceans such as the Pacific, and to map island systems encountered, adding them to the global atlases enabled by the grid.

4.1.2 Polynesian "Mapping"

While the Greeks were developing "geometry," Italians exploring perspective painting, and European seafarers traveling along the coastal zones, afraid of losing sight of land as their means of orientation, people of Polynesia navigated with accuracy and precision from one remote island to another, without the use of any onboard written map, or any tools or technologies Europeans associate with navigation. When the Micronesians traveled from the Marshall Islands to Hawai'i around 100 AD., probably just before Ptolemy was born, they were already seasoned navigators on the largest ocean on the planet.

While voyaging through vast distances, Pacific navigators had no drawn maps, books or journals with the recorded knowledge of a specific region: how was this possible? The navigators instead carried with them a highly evolved navigational knowledge system that allowed them to visit the more than 10,000 islands in the Pacific long before the European explorers arrived in the region a few centuries ago (Witt-Miller, 1991: 64). Their method of orienting themselves spatially was based on an intimate experiential perception of their lived reality, stored in their memory and transmitted orally from generation to generation. A long and arduous process had to be gone through to acquire the vast knowledge necessary to cross vast distances on the ocean out of sight from land. The training or apprenticeship would begin around the age of 12 and often was not completed until the early thirties. Farrall describes part of the training a navigator must go through.

In the course of his training a navigator has to memorize large amounts of information about the positions and movements of the stars; the relative positions of islands, reefs and other geographical features; the patterns of winds, waves, and ocean currents; and the kinds and habits of the sea birds. He has to learn the theories associated with understanding all this information. He also has to learn the theory of *hatag* (or *etak*) used to keep track of

where a canoe is during a journey, and then put the theory to practice. The navigator must also be familiar from personal experience with the handling of sea-going canoes and how to keep on course at all times of the day and night. (Farrall, 1979: 48, 52)

The knowledge of the navigator was not readily available, but was rather something the student was initiated into by a master navigator, when appropriate understanding and maturity had been gained. "There was much magic and esoteric knowledge which could be known only by the privileged few.... In addition the navigational skills were and still are valuable property, willingly passed on to relatives but taught to non relatives at a steep price" (Ibid: 34).

All knowledge was communicated orally or through direct experience utilizing all senses, stick and pebble maps to illustrate wave patterns, and the star compass to learn about the sky. Seen in this perspective mapping becomes an art of reading the environment; the territory becomes the map.

There are several reasons why the islanders were interested in communicating with others in distant islands. Those who could safely navigate and often also built the canoes made it possible for the rest of the society to overcome the barrier to communication imposed by the open sea. Farrall elaborates on other reasons in a Micronesian context.

"There are features of the natural environmental setting of the Western Carolines which encourage the development of a system of inter island social ties. Among such environmental characteristics are (a) the restricted land areas of the Western Caroline Islands, (b) the limited range of agricultural staples available, (c) the hazards and uncertainties of marine exploitation, and most important, (d) the destructive effects of tropical storms" (Ibid: 8).

Without oceangoing canoes and navigational knowledge Micronesians could not have engaged in the exchange of goods, marriage partners and ideas; ultimately the survival of the people was at stake. This reality gave the master navigator a highly respected and influential status among the people. With such concentration of knowledge among a very limited group of people, complex issues of power arose which in Polynesia were dealt with in many ways. Farrall describes the situation of the Puluwatans.

...navigational knowledge enabled Puluwatans to communicate with other Micronesians but it did not mean that there was necessarily a relationship of power between the groups thus brought into contact. Without the knowledge it would have been impossible for the Puluwatans to have dominated over groups, but the possession of the knowledge did not give the Puluwatans power over other peoples. In modern industrial societies it is clear that certain kinds of scientific knowledge are crucial in the provision of military power. (Ibid: 13)

The Micronesian navigators are an excellent example of how navigational expertise can grow out of a specific context as opposed to a European, non-local method of navigational knowledge. The knowledge

carrier is an integral part of the society's well-being through his close connection to the place where he lives. "The wayfinder concentrates 100 percent of his attention on his place in the sea and sky. With his one-pointedness, he processes all of his data on his course, speed and current, etc. His point of concentration is his navel, called the *piko* in Hawaiian. This is considered the center of the one's body and being, so that it - not the brain - is the point from which to live" (Witt-Miller, 1991: 65). As a last note in this brief section, we would like to quote Witt-Miller on how the epistemology of Polynesian navigation differs from that of Western science.

The radical technology of wayfinding shocks us with its independence of our technology. But what really threatens our view of the universe is the complex array of totally unrelated inputs - just about everything from stars to pig snouts to testicles - that the wayfinder weaves into a picture of his position. Most of these inputs are from phenomena that don't lend themselves to precise measurement and, because they're of different orders, don't allow like-to-like comparison. Yet measurement of comparable things is essential to classical science. (Ibid: 69)

Surrounded by a vast ocean in all directions, Hawai`i was protected from colonization, exploitation and foreign control longer than most places on Earth. Prior to 1778, Hawai`i was not yet "discovered" - it was not on the map in the Western sense, and therefore was still mapped according to the Hawaiians' own integral sense of the land and the sea. Dudley tries to describe what this would have looked like:

Since the islands are roughly circular, the *ahupua`a*...traditional land divisions in Hawai`i...the subdivisions of a district, can be pictured as thin slices of a pie. The narrow end of the *ahupua`a* is at the thin slice of the pie...the narrow end of the *ahupua`a* is at a central or inland mountain top, and it broadens out as it progresses towards the shore and out into the sea. Each *ahupua`a* was for the most part self-sufficient, producing everything needed by the people living within the boundaries. People did not live in the villages: their homes were scattered over the area of the *ahupua`a*. Hawaiians had no money and did not barter. But those who fished in the sea needed to fill their diets with the crops that others raised in the uplands, and the uplands needed fish. Society was based on generosity and communal concern. Fishermen gave freely, and farmers gave freely. And all flourished. A *konoiki*, or overseer, assured that a constant flow of products moved through the *ahupua`a*, meeting everybody's needs. (Dudley, 1990: 65)

When the Hawaiians, having existed on the most isolated land mass on the planet, saw giant white sails in their harbors for the first time, it is hard to imagine what they might have thought.

4.1.3 The First Maps of Hawai`i

When the British Commander, surveyor and cartographer James Cook set out for his third voyage in the Pacific it was to investigate the western coast of North America in the "hope that he would discover the Northwest passage, the long sought-for connection between the Atlantic and the Pacific ocean" (Fitzpatrick, 1990: 14).

Cook's travels were made feasible by instruments and technologies which had only recently been invented: he was able to place himself squarely on the world grid at any point in his journey. "Cook was fortunate enough to be living in a time when science and technology combined to produce not one but two reliable methods of determining longitude, a problem which had plagued man since the days of the Greeks" (Ibid: 14).

For his third journey in the Pacific, Cook was given the following instructions, as quoted by Healy:

At whatever places you may touch in the sources of your voyage, where accurate observations of the nature hereafter mentioned have not already been made, you are, as far as your time will allow, very carefully to observe the true situation of such places, both in the latitude and longitude; the variation of the needle; bearings on headlands; height, direction, and of course of the tides and currents; depth and soundings of the sea; shoals, rocks, etc.; and also to survey, make charts of the coast, and to make notations thereon, as may be useful either to navigation or commerce. (Healy 1959: 9)

While captaining two ships, "Resolution" and "Discovery," bound from Tahiti to the Northwest coast of America, Cook noted the following in his diary,

Friday, 2nd January, 1778 We continued to see birds every day of the sorts last mentioned, sometimes in greater numbers than others: and between the latitude of 10 and 11 we saw several turtles. All these are looked upon as signs of the vicinity of land; we however saw none till day break in the morning of the 18th when an island was discovered bearing NEBE and soon after we saw more land bearing North and entirely detached from the first; both had the appearance of being high land.... (Price 1969: 215-6)

When we are looking at the first map by Cook's crew (Figure 4.6) we see a map of the Hawaiian islands that has a high degree of accuracy.

This is the first time the islands were placed in their "correct" geographic, spatial relationship in the world view originally proposed by Ptolemy. The archipelago of Hawai`i would no longer be the same, now becoming part of a mapping grid that connected all observed geography into one central framework. This was in many ways a huge breakthrough for the charting of the world, initiated by the imperial powers of Europe.

The Hawaiian islands became part of a shared knowledge system, which all navigators who could measure their position in accordance with longitude and latitude could visit by choice. The knowledge of the indigenous Pacific navigators was thereby challenged by people who had absolutely no local knowledge or experience with the particular places they visited.

The specific location of the Hawaiian islands was noted by Captain Cook in his journal on Friday the

30th, 1778, a year which forever changed the course of life on the Hawaiian islands. Cook wrote:

Friday, 30th January, 1778 These five islands Atoui, Eneeheeu, Orrehoua, Otaoora and Wouahoo, names by which they are known to the Natives. I named them Sandwich Islands, in honor of the Earl of Sandwich. They are situated between the Latitude of 21° 30' and 22°15' N and between the Longitude of 199° 20' and 201° 30' East. Wouahoo, which is the Easternmost and lies in the Latitude of 21° 36' we knew no more of that than it is high land and inhabited.... (Ibid: 221)

Thus charted, the Hawaiian archipelago was subject to the influence of the rest of the world.

In this section, we have taken a journey through time and space, from the Greeks' invention of geometry to placing Hawai`i reliably on the longitude/latitude grid, though this merely marks the beginning of a larger journey we are taking toward understanding the long-term implications of this grid, written and computerized maps, and local and "universal" knowledge. In the next section, we give a very brief history of Hawaiian exploitation by the West, which again, is made possible by the newly acquired ability to find this remote land mass by map.

[CONTENTS](#)

[REFERENCES](#)

4.2 Hawai`i - Consequences of Being "On The Map"

While the actual history of the last 200 years in Hawai`i is very complex and cannot be reduced to "good Hawaiians, bad Europeans," following European contact, the highly productive, complex and sustainable cultural systems of the indigenous people of Hawai`i, the Kanaka Maoli, were seriously disrupted. In a series of major changes, missionaries, business people, imported laborers, new technologies, exotic species, and new ideas would transform this remote archipelago which had remained hidden to non-Pacific islanders for millennia.

Aided by Europeans, King Kamehameha I was able to unify the previously politically separated islands under one rule, ending the continuous wars among the islands by 1820. An absolute monarchy was created which put total control of the land under the King. In time, King Kamehameha III put the control of the land and the power of the Kingdom under a constitution, creating a constitutional monarchy.

The first major ecological and economic impact after the arrival of the Europeans was the exploitation and annihilation of the sandalwood forests, in the early 1800's. Sandalwood was exchanged for the first western weapons, clothes, and tableware the Hawaiians had ever seen.

After the exhaustion of the sandalwood forests the extensive whaling industry followed, which brought

many more ships to Hawai`i than had ever been there before. Between 1840 and 1870 when whaling was at its peak, this industry became the basis for the money economy of Hawai`i and established town life on the islands, with intensive commercial exchange: "For the first time the Hawaiian masses were drawn into the cash economy as workers and producers on a regular basis" (Kent, 1983: 22). These developments would provide the foundations for what later would become the metropolitan center of Honolulu. By the 1840's six hundred whalers were appearing every year. After 1860 the whaling industry began to decline first because whales became more scarce and voyages thus more costly and secondly because the petroleum was displacing the whale oil market.

Due to the increasing demands of visiting ships, the next wave of mapmaking, after the maps of the islands and surrounding waters created first by Cook and followed by La Perouse and Vancouver, was focused on harbors. The Russian navigator Kotzebue made the earliest known map of Honolulu in 1817, as shown in Figure 4.7.

Following Cook, subsequent mapping efforts for navigational purposes, harbor locations, natural resources, property surveys for privatization of land were all done by Europeans, since they introduced and practiced the skills involved. The "Europeans made maps for their own use, not for the Hawaiians" (Fitzpatrick, 1990: 13).

Sugar came in with whaling after sandalwood as the economic engine of the islands. In 1835 the first Western style sugar plantation was established, which was very labor intensive, a factor which led to the subsequent importation of Chinese and Japanese workers. This industry was extremely influential in the social, economic, and political life of Hawai`i through much of the last two centuries.

Perhaps the most dramatic impact on the people and land of Hawai`i came about through the land reform called the "Great Mahele," in 1848. Before the reform no one owned land in the Western sense nor was the land bought or sold; instead the land was regarded as a sacred entity governed by the chiefs and the king, and was divided up between the king, the chiefs and the government. Two years after this law was passed another law made it possible for foreigners to buy and sell land; the importance of this law for the changes that followed cannot be overstated. The Great Mahele fundamentally disrupted the native Hawaiians' ability to sustain themselves on the land and thereby their ability to lead sustainable lives. Lilikala Kame`eleihiwa (1994) comments that the privatization of land was perhaps the biggest mistake the Hawaiians had ever made because it allowed foreigners to buy Hawai`i (Kame`eleihiwa, 1994: 114). Writing about the Mahele, Marion Kelly (1994) maintains that the Mahele "turned out not to be an act of generosity, but an act of genocide" (Kelly, 1994: 105). Dudley writes about this pivotal point in Hawaiian history:

While Native Hawaiians may have been unaware of the great value of a clear land title, the white people in the islands, familiar with the capitalist system, were very aware of its value. They used their store of wealth to buy up every piece of land they could. By the end of 1850, the same year the law was passed allowing purchasing of lands by anyone, thousands of acres of land had been sold to whites. Within two more years, the acres sold

would be in the hundred of thousands. Before the monarchy came to an end forty years later, most of the chiefs' lands and vast parts of the crown lands had been sold to whites. (Dudley, 1990: 20)

That the Mahele was a mistake or an act of genocide without any benefits for Hawaiians has been challenged recently, though it is true that the Mahele dramatically changed the relationship between people and land in Hawai'i. This no doubt led to new and very different maps of island territory than anything the native Hawaiians would have imagined. The islands were no longer arranged for integration and sustainability, but rather for exploitation by foreign interests.

Another important event relating to maps in Hawai'i's history is the arrival of the Christian missionaries. In their work over the last 200 years toward 'enlightening the natives,' "education" played a central role. Their activities were aimed at making the Hawaiians proficient at reading the Bible: toward this end they built schools, trained teachers, and established printing presses. Fitzpatrick (1990) writes, "With the development of the educational program of the missionaries there arose a need for maps. Acquainting the Hawaiians with the geography of the Bible requires maps, as did pointing out the relationship of Hawai'i to the various components of the Christian and 'heathen' worlds" (Fitzpatrick, 1990: 105). The missionaries then were also catalysts in the making and distribution of maps and the obliteration of indigenous knowledge through Westernization.

Suddenly the indigenous people of the land were shunned, their knowledge of living with and caring for the land was dismissed, and children were taught the English language, English and European Literature, US Politics, World History, and (Christian) Religion.

While the impact may be difficult to quantify precisely, one might expect that such education and foreign influence and knowledge maps had significant effects on indigenous people.

4.2.1 Sovereignty Lost

One hundred and fifteen years after the arrival of Cook, the Hawaiian islands were governed by a Queen, in a monarchy recognized through Treaties of Friendship, Commerce, and Navigation with the major sovereign powers existing at that time (Laenui, 1993: 81). Although the United States was one of the countries with treaties to Hawai'i, the US military supported the overthrow of the Hawaiian government in 1893 by a small group of Western businessmen.

In understanding Hawaiian history and the current Hawaiian sovereignty movement we have found it helpful to be especially aware of several historical issues and developments. First, in 1887 the "Bayonet Constitution" was drafted at the initiative and under the influence of Westerners, and extended the vote to American and European males, reduced the King to a ceremonial position, and raised property qualifications to a level where many native Hawaiians were prevented from voting, among other constitutional changes. While it was a very significant step in enabling more than a century of foreign influence in Hawai'i, the Bayonet Constitution was never ratified by the legislature of the time.

Second, the role of the sugar industry in the overthrow of the Hawaiian government was significant. In 1891 a sugar tariff was levied by the United States on Hawaiian imports, and it took a major toll on the local sugar industry. "While sympathetic to annexation, the Harrison administration was not sympathetic to lifting the tariff. It appeared to some that the only way Hawaiian sugar could be guaranteed a portion of the American market was for Hawai`i to become part of the United States" (MacKenzie, 1991: 12).

Third, Queen Lili`uokalani took the throne upon Kalakaua's death in 1892, and was in the process of drafting another constitution to limit the influence of Westerners when she was deposed. However, it is important to note that though removed from office she did not abdicate her throne, instead yielding her authority at gunpoint while making the following statement:

I, Lili'uokalani by the grace of God and under the constitution of the Hawaiian Kingdom, Queen, do hereby solemnly protest against any and all acts done against myself and the constitutional Government of the Hawaiian Kingdom by certain persons claiming to have established a Provisional Government of and for this Kingdom. Now, to avoid any collision of armed forces and perhaps the loss of life, I do, under this protest, and impelled by said force, yield my authority until such time as the Government of the United States shall, upon the facts being presented to it, undo the action of its representatives and reinstate me and the authority which I claim as the constitutional sovereign of the Hawaiian Islands. (Lili'uokalani, 1893)

It is significant to consider that the Queen did not know whether such reinstating would happen in a day, a year, or a century.

Next, Grover Cleveland, the American president at the time, was quite opposed to the U.S. military-sanctioned overthrow in Hawai`i. In an extensive and passionate speech to the U.S. congress on December 18, 1893, Cleveland identified that in the overthrow of the Queen, a "substantial wrong" had been done to U.S. national character and to native Hawaiians, and demanded that it be repaired by the restoration of the monarchy. The following key excerpts of his speech are illuminating:

By an act of war, committed with the participation of a diplomatic representative of the United States, and without authority of Congress, the Government of a feeble but friendly and confiding people has been overthrown.... A substantial wrong has thus been done which a due regard for our national character as well as the rights of the injured people requires that we should endeavor to repair.... I instructed Minister Willis to advise the Queen and her supporters of my desire to aid in the restoration of the status existing before the lawless landing of the United States forces at Honolulu on the 16th of January last.... (Cleveland, 1893)

Unfortunately for native Hawaiians, the less sympathetic William McKinley was elected president before Cleveland could move to reverse the overthrow. Even after Cleveland had clearly recognized this

situation to be an illegal occupation, the next president, William McKinley ignored his position and made the decision to allow the occupational force to remain in control of Hawai`i. This force and its associates claimed all the "Government Lands" at the time of the overthrow. It is poignant to note that Sanford P. Dole, a businessman (and grandfather of 1996 US presidential candidate Robert Dole), was installed as the first president of what became known as the "republic of Hawai`i."

After a lengthy debate in the US between anti-expansionists and annexationists, Hawai`i was annexed by the federal government of the United States, in 1898. Following annexation the "Organic Act" of 1900 was passed, which established a territorial government with a structure like most states in the U.S., except that the primary officials were appointed by the federal government, which had ultimate authority, rather than the people of Hawai`i. In addition, 1.75 million acres of Hawaiian public lands were ceded to the United States from the republic, which had "acquired" the lands from the monarchy. It is important to note that while the U.S. had "legal title" to the land, "the beneficial title rested with the inhabitants of Hawai`i... Section 73 of the Organic Act stated that the proceeds from the territory's sale, lease, or other disposition of these ceded lands should be deposited in the territory's treasury for "such uses and purposes for the benefit of the inhabitants of the Territory of Hawai`i as are consistent with the joint resolution of annexation... Nevertheless, the federal government also reserved the right to withdraw lands for its own use" (MacKenzie, 1991: 15, 16).

Devaluation of Hawaiian culture, overthrow of the Hawaiian government, loss of land and control over personal, cultural, and economic self-determination all had significant impacts on the indigenous people of Hawai`i, which were evident early in this century. Some of these impacts are described in a 1964 report which is quoted by MacKenzie,

Available social statistics indicate that as of 1920 the position of the Hawaiian community had deteriorated seriously. The general crime rate for people of Hawaiian ancestry was significantly higher than that of other groups. The rate of juvenile delinquency was also higher, an ominous omen for the future. Economically depressed, internally disorganized and politically threatened, it was evident that the remnant of Hawaiians required assistance to stem their precipitous decline. (Ibid: 17)

As a response to this decline, the Hawaiian Homes Commission Act was passed in 1921. "Under the act, about 188,000 acres of public lands were designated as "available lands" and put under the jurisdiction of the Hawaiian Homes Commission to be leased out to Native Hawaiians, those with 50 percent or more native blood, at a nominal fee for 99 years" (Ibid: 17). Conceived as a way to benefit native Hawaiians and as an agricultural initiative and experiment, the Act was quickly coopted by sugar interests so that little agriculturally productive land would be leased out, and arranged to limit those who could apply by setting a "blood quantum" (prerequisite) of Hawaiian ancestry at 50 percent. Bureaucracy and other factors led to the slow dispersal of leases, and tens of thousands of Hawaiians have waited decades on lists to receive land, or are still waiting today. In 1989, just under 6,000 native Hawaiians leased 32,713 acres of Hawaiian Homestead land (Ibid: 18).

The development of the tourist industry after World War II pushed many of the remaining native Hawaiians and their culture further toward the edge of annihilation. Land speculation drove up prices so that native Hawaiians were driven away to marginal property, and then often to their cars and the beaches. With the influx of new people, ideas, and "modernizing" plans for the Islands, Hawaiian culture was considered truly "backward" and devalued: "progress" had come to Hawai`i.

Waikiki, the primary tourist center in Hawai`i, provides perhaps the most extreme example of the transformation exacted upon the people and land of Hawai`i by foreigners, and by tourism. Barry Nakamura (1979) writes in great detail about the radical changes in land use that occurred at Waikiki in the early 20th century, in his Master's Thesis The Story of Waikiki and the "Reclamation" Project. "As early as in the 15th century, the Native Hawaiian people engineered and developed at Waikiki, extensive taro pond fields and an irrigation system which decentralized the water resources of the mountain streams which flowed into the Waikiki hinterland" (Nakamura, 1979: vi). When Europeans arrived, what is now called Waikiki was the bottom of a highly productive *ahupua`a*, which fed many people with taro, fish and other foodstuffs through an intricate, highly developed system of streams, terraces, and ponds. A complex series of interrelated developments and deliberate planning by government business alliances led to the transformation of Waikiki from its role in supporting indigenous people in sophisticated subsistence lifestyles, to increasingly being populated to non-Hawaiians, and filled with hotels and streets (John Kelly, personal communication). In the following excerpt, Nakamura describes the official motive for destroying this once "most extensive area of wet-taro cultivation on Oahu" (Handy, 1972: 480).

The Sanitary Commission of 1912 estimated that, of the total amount of land in the district of Honolulu located below the foothills, one third was wet land. This wet land, which was used for agriculture and aquaculture, represented, then, a considerable amount of urban real estate if filled in.

Such laws as Chapter 83, R.L. 1905 already existed to deal with filling in wet land. The justification for such actions would be sanitation, that is, if wet lands were allowed to exist within the district of Honolulu, the public health would be endangered, for mosquitoes, carriers of dangerous diseases, would continue to breed... Thus sanitation was presented as the primary motive in the destruction of wet agriculture and aquaculture while the profitability of reclaimed was hardly mentioned at all. (Nakamura, 1979: 67)

In 1959, following a plebiscite process which was at the time, and has been subsequently deplored by many native Hawaiians, Hawai`i became the fiftieth state of the United States of America through the unprecedented "Admission Act." This Act not only gave control of most of the ceded lands held by the federal government to the state, but provided a requirement for the state to hold these lands "as a public trust for the support of the public schools and other public educational institutions, for the betterment of the conditions of native Hawaiians..." (MacKenzie, 1991: 19). However, almost twenty years passed before actions were taken per the Act's trust language toward the "betterment of the conditions of native Hawaiians."

In 1964, Holt published On Being Hawaiian, a book that contributed to the advent of a cultural renaissance which has increased in intensity in the face of a dominant culture which has held that Hawaiian culture is antiquated and without worth, and that the American hegemony over the islands is a part of "Manifest Destiny" of inevitable control. Against many odds, native people of Hawai`i are again learning their original language, their history, their traditional spirituality, their ancient livelihood practices, and are challenging the legitimacy of the Anglo-Japanese socio-political hegemony in the region. A systematic exploration of the effects of Euro-American trade and exploitation, the illegal coup de 'etat, annexation, land appropriation, statehood, militarization, standard western education, tourism, and ecological devastation has only begun. Essential literature relating to this native culture renewal include Kame`eleihiwa's (1992) Native Land and Foreign Desires, Dudley's (1990) A Hawaiian Nation series, Hasager's (1994) Return to Nationhood, Trask's (1993) From a Native Daughter, and Handy's (1972) Native Planters. These works attempt to give the history of Hawai`i from a native perspective, and offer significant additions and revisions to the previously written version.

This reemergence of Hawaiian cultural values and pride led in 1978 to the convening of a Constitutional Convention at which the language of the Admission Act was clarified and expanded to establish native Hawaiians and the general public as the two beneficiaries of the lands ceded to the state by the Act. In addition, the [Office of Hawaiian Affairs \(OHA\)](#) was created to administer twenty percent of the ceded land revenues to benefit native Hawaiians. Why OHA only administrates the revenues derived from ceded land leases and sales and not from the revenue generated from businesses on ceded land is

... [one of] many unresolved issues relative to the public land trust and its proceeds and income [which] remained. Disputes over the classification of specific parcels of land as ceded or non-ceded, questions as to whether section 5 (f) contemplates gross or net income, and problems in defining "proceeds," have plagued the state and hampered OHA in effectively carrying out its responsibilities to native Hawaiians. (MacKenzie, 1991: 20)

The story of OHA is an intricate and complex one that we will not tackle here in any detail. It is enough to point out that OHA is set up as a separate state agency outside of the control of the executive branch with a stated intention to provide a vehicle for native Hawaiian self-government and self-determination, and to point to the many unresolved problematics and tensions with the state, within OHA, and among its trustees in fulfilling OHA's mission.

As this thesis goes to press, an article in the Honolulu paper suggests that for many native Hawaiians, life is not easy in 1996.

Native Hawaiians face some of the worst housing conditions in the United States, says U.S. Sen. Daniel Inouye. Their plight has been hidden because data on native Hawaiian housing needs were incomplete, Inouye said. New studies bear "astonishing findings and statistics - findings which are shocking even to those who may consider themselves well-informed on these matters," he said.

Among the findings: Nearly half of Hawaiian households - and 67 percent of those on the waiting list for Hawaiian Home lands - experience housing problems related to affordability, overcrowding or structural inadequacy. That compares with 44 percent of American Indians and Alaska Natives living on tribal lands and 27 percent of all U.S. households. The rate of homelessness among Hawaiians, at 12.2 "households" per 1,000, is double that of non-Hawaiians.

"It's at a point where I don't think it could get any worse," said Jim Dannemiller of SMS Research, which helped compile data. (Christensen, July 4, 1996, Honolulu Star-Bulletin)

To summarize the main points of this section, Hawai`i provides a dramatic example of the effects on a specific bioregion of colonialism and mass-market capitalism; of being introduced to "the grid" of global maps and economy. It cannot be restated too often that from being a "highly organized, self sufficient, subsistent social system based on communal land tenure with a sophisticated language, culture, and religion" (U.S. 103rd Congress, 1993) before the arrival of missionaries and trades people in 1778 led by Captain Cook, Native Hawaiians have almost been annihilated from the face of the earth. In a little more than a century after Cook's arrival, the indigenous population decreased from an estimated one million inhabitants to approximately 40,000. Today as the Hawaiian people are finally gaining recognition for the many years of genocide against their people, less than 8,000 full-blood Hawaiians are left. The remaining Kanaka Maoli, the native people of the islands, are widely regarded as some of the most disadvantaged, oppressed, and unhealthy people in what is called the United States.

Hawai`i is the most geographically isolated archipelago in the world, and originally had a tremendous diversity of microclimates, life forms, and natural renewable energy sources. Despite its natural wealth, Hawai`i now imports 50-75% of its own foodstuffs, and over 75% of its energy (Department of Geography, U. Hawai`i, 1983: 159). Ecological degradation over the last century, caused by development and ignorance, has caused many species of life to become extinct, and still threatens many more. The transformation of the Islands from a series of rich, dynamic and interconnected ecosystems and cultural systems to its present state is one of many factors that has intensified a movement toward reclaiming Hawaiian sovereignty.

4.2.2 Sovereignty Regained?

It is among the remaining full-blooded Hawaiians, the 220,000 mixed-blooded Hawaiians, and empathetic haoles that different scenarios of Hawaiian sovereignty are being formed. Hawaiian history has given birth to several attempts at the creation of a sovereign state. In 1996, sovereignty in some form has moral support at the highest levels of state government, as Senator Inouye and former Governor Waihee suggest.

It is my sincere hope that the sovereignty of the Hawaiian people will be restored in my lifetime,' says US Senator Daniel Inouye (D) of Hawai`i. 'I stand ready and willing to act on ... legislation at the request of and on behalf of the American people.'

'There are few today who doubt that sovereignty will happen,' Governor Waihee adds. 'It's a matter of how, when, and in what form.'

Close observers say most vocal proponents of sovereignty fall into three categories: 1) Those demanding complete separation from the US and a return to independent, internationally recognized status; 2) Those desiring nation-within-a-nation status with federal recognition as a new, native-American nation; 3) Those wanting to maintain the political status quo while forging ahead for both reparations and full control of Hawaiian trust assets by Hawaiians. (Wood, 1994: 10)

On November 23, 1993, the United States Congress and President Clinton formally apologized to the native people of Hawai'i for the overthrow of the Hawaiian Queen Lili'uokalani in 1893, by passing US Public Law 103-150. In Public Law 103-150, the United States government states its official recognition of its own complicity, its apology, and its commitment to reconciliation, without any ambiguity:

Whereas, in pursuance of the conspiracy to overthrow the Government of Hawaii, the United States Minister and the naval representatives of the United States caused armed naval forces of the United States to invade the sovereign Hawaiian nation on January 16, 1893, and to position themselves near the Hawaiian Government buildings and the Iolani Palace to intimidate Queen Lili'uokalani and her Government...

Whereas, it is proper and timely for the Congress on the occasion of the impending one hundredth anniversary of the event, to acknowledge the historic significance of the illegal overthrow of the Kingdom of Hawaii, to express its deep regret to the Native Hawaiian people, and to support the reconciliation efforts of the State of Hawaii and the United Church of Christ with Native Hawaiians.... (U.S. 103rd Congress, 1993)

Professor Francis Boyle, an international law expert and Professor at the University of Illinois at Champaign, has represented the Palestinians in their successful struggle for sovereignty, is currently giving legal advice in the Serbian-Croat conflict in the Balkans and is also giving advice to the Nation of Hawai'i. Professor Boyle has made public statements regarding the legitimacy of the Nation of Hawai'i which have illuminated the issue of sovereignty in light of U.S. Public Law 103-150. In Honolulu, on December 28, 1993, Professor Boyle stated the following:

Through 103-150 they (The United States of America) are admitting that the invasion, overthrow, occupation, annexation, starting in 1893, on up, violated all the treaties, violated basic norms of international law, and the United States Constitution... (it was) the overthrow of a lawful government... Under international law when you have a violation of treaties of this magnitude, the World Court has ruled that the only appropriate remedy is restitution.

Whose land is it? Well, from what the Congress seems to be saying, it's the land of the Native Hawaiians. The Native Hawaiian people *still have sovereignty*... You can't trespass on your own land. The trespassers then become the State of Hawai'i, and the land developers, and the golf courses, and the resorts. You are simply the Native Hawaiians asserting your rights under international law... This reversal of positions, between who is the criminal and who is the victim, who is asserting their rights and who is violating their rights, has been effectively conceded by Congress. (Boyle, 1993)

Today, the sovereignty movements of Hawai'i are gaining greater prominence as conferences, media attention, and international sympathy build toward some form of reconciliation. There have been several socio-political manifestations of the native sovereignty movements; we will allude here to two of them, and the establishment of their own constitution. First, the movement for nation-within-a-nation status:

Although the initial efforts of the Ho 'ala Kanawai movement were curtailed by the state, native advocates continued to meet and develop a strategy for self-determination. From 1983 to 1987, a coalition of native leaders called the Native Hawaiian Land Trust Task Force began workshops in all native communities throughout the Islands which focused on the right of self-determination of the Hawaiian people. This movement grew through several successive political and educational undertakings which reviewed native history prior and subsequent to the overthrow, native efforts to regain sovereignty and the inherent cultural and political rights of native people. These efforts culminated in a native Constitutional Convention which was held in January 1987. What emerged was a new nation - Ka Lahui Hawai'i (The Gathering of Hawai'i). (Hasager, 1994: 82)

Another group is pressing for full Hawaiian sovereignty as an independent nation and has only recently declared its independence and created a constitution following the passage of U.S. Public Law 103-150, and after legal advice and encouragement from Professor Boyle. On January 16, 1994, 101 years after the US-backed overthrow, 400 people gathered at the Iolani Palace, the former residence of the deposed Queen Lili'uokalani. At this meeting a representative from the Kanaka Maoli declared in accordance with Article 1 of the United Nations charter, "We hereby reestablish our independent and sovereign nation of Hawai'i that was illegally taken from the Kanaka Maoli." This proclamation empowered a council of elders to establish a provisional government of Hawai'i, called "The Nation of Hawai'i."

A few months later, 200 *kupuna* (elders) gathered on Maui for the first plenary session of the provisional government. At this meeting Mr. Pu'uhonua Kanahale was selected as the Head of State for the provisional government, and the work to establish a new constitution was begun. In October of 1994 the revised constitution was completed by an all-island gathering of Hawaiian elders: it was written in the Hawaiian language and served as the only official document of the Nation of Hawai'i.

Francis Boyle's advice to the Nation of Hawai'i has been essential in helping to chart its course; however recent developments may lead the Nation to rest on older foundations, and navigate in new directions.

One of these recent developments is a movement to challenge land titles that cannot be traced back to the constitution of Kamehameha III. Today some native Hawaiians are maintaining that the original Hawaiian law based on the constitution of 1840 is in fact still the law of the land, given that the "Bayonet Constitution" of 1887 was never ratified. Certain individuals have had title searches done through "Perfect Title Company," and have now stopped paying their mortgages to their bank, instead paying mortgage into an escrow account (based on guidelines from the 1840 constitution) set up as a vehicle to support an independent Hawaiian government. How this development will affect the sovereignty movement is unclear, but it will likely be an important issue to watch in the future.

Another important development is the publication of, and distribution of ballots by the Office of Hawaiian Affairs (OHA), for an upcoming "Hawaiian vote" to determine whether people of Hawaiian ancestry desire to formally explore the creation of a Hawaiian nation of some kind. Some groups, like Ka Lahui Hawai`i, urge active opposition and even sabotage of the vote, calling it "controlled by the State," and suggesting that it is a lose-lose situation for Hawaiians. Others, including the Nation of Hawai`i, are encouraging participation as a way to bring Hawaiians together and discuss (among other things) the importance and continuing relevance of the original constitution of 1840. Bumpy Kanahela of the Nation of Hawai`i has stated that since sovereignty groups have been unable to reach really broad audiences thus far, he sees this event as a rare opportunity to gather mainstream Hawaiians to talk and learn about sovereignty.

In general, we have found that there is much going on in Hawai`i with regard to sovereignty which is not written about or covered by the media: it is often difficult to learn about what is actually happening in the present, and even more so what has actually happened in the past. Our historical and contemporary overview should be seen in this light - as a broad, surface sweep of main issues and events we are offering to help the reader to begin to better understand this place and this people in light of research topics we are exploring. A deeper understanding and treatment of these issues would require much more extensive research, and a much more ambitious paper.

Before discussing in some detail our work with GIS with Hawai`i and the Nation of Hawai`i, it is important to first turn to some further considerations of the history of GIS and the context in which it has developed.

[CONTENTS](#)

[REFERENCES](#)

4.3 Context and History of GIS

We begin here by acknowledging that any discussion of the history of GIS must be full of assumptions and theory. To try to relate an "objective" history of this technology's development would be both unrealistic and unwise; instead, we will give a succinct technological history based on specific materials we have read, and will situate this history in the context of larger social forces, which may illumine a

deeper understanding of GIS.

We have found that there are three issues that need to be considered with regard to the history of GIS: 1) this is not a subject that has been extensively written about; 2) the histories that exist are written largely from a user or developer's perspective and not from a broader contextual and social historical perspective; and 3) a more in depth and broader history is only just being initiated (Pickles et. al. 1996, in progress) that situates GIS in a larger intellectual and social context (Jon Goss, personal communication).

In this section we will first describe what we have learned of GIS' development that is relevant for this paper; second, we raise some questions relating to a social history of GIS, and third, we discuss what we have learned of the use by indigenous peoples of GIS.

4.3.1 GIS Development

It is important to emphasize that with respect to GIS history, there are differing interpretations and perspectives - there is not one source of "objective facts;" two useful sources of GIS historical interpretations are Joseph Berry, a writer for the magazine "GIS World," and Roger Tomlinson, who heads a private Canadian GIS consulting firm.

Tomlinson (1984) suggests several points to be considered in understanding the original emergence in the 1960's of what has come to be called geographic information systems. The realization that Canada's seemingly endless natural resources were actually limited and the subject of fierce competition, created an awareness in the Canadian government of the need for new data to help understand and inventory these resources. However, while Canada was a "relatively wealthy country at the time ... (and) it could afford to gather the data and make the maps, the manual techniques of map analysis required thereafter were extremely labor intensive and time consuming ... Quite simply, Canada did not have the trained people needed to make use of an extensive land survey" (Tomlinson 1984: 19). Thus, the very first GIS was developed for the Canadian government as a cost-effective and practical solution for the analysis of its land survey, though technological limitations were to dictate what was possible and impossible. Despite an important technological development - the supercession of the cumbersome vacuum tube by the much faster and smaller transistor - computing power in the 1960's was still relatively slow, computers were prohibitively expensive, and computer memory was small.

Tomlinson maintains that given these points, the central challenge of that time was "...the direct translation of traditional, manually-oriented techniques into the computer..." (Ibid: 6). Mirroring the compiling of traditional maps by the grid of longitude and latitude into atlases (see theory section), now a new challenge emerged: to compile and link maps in a digital form, forming a "complete picture of the natural resources of a region or of a nation or a continent" (Ibid: 19), to be analyzed by computer in order to provide useful and comprehensive information.

In understanding GIS history and more fully grasping the present state of the technology, it is helpful to understand how different the technological landscape of the past has been from that of today:

Certain technological constraints had to be overcome. No efficient way existed for converting large numbers of maps to numerical form. Computers still had small storage capacities and slow processing speeds by today's standards. The largest machine available for early work on GIS was the IBM 1401 with 16K of BCD memory; it processed approximately 1,000 instructions per second, cost \$600,000, and weighed more than 8,000 pounds.... In April 1964, the IBM 360/65 was introduced. This was a major step forward. It had a maximum of 512K bytes of memory and processed 400,000 instructions per second. It cost \$3-4 million and weighed 10,000 pounds. Tape was the preferred storage medium. Disks were not in widespread use in the early 1960s; the ones that existed were too small in capacity and access was too slow. (Ibid: 20) *(I think about this every time I curse my Apple "Powerbook" when it is running slowly under the weight of four big software applications! With 24,000K bytes of RAM memory, 250,000K bytes of hard drive memory, purchased for \$2,000 in 1995, and weighing in at 5 lbs, perhaps we all need to consistently take time to put things in perspective.... -Christopher).*

Tomlinson suggests that the increasing involvement of Western governments in land management and environmental concerns in the 1970's expanded the need to manage vast amounts of data much more quickly than traditional map analysis allowed. Relevant computer developments included advances in "user friendliness" and declining costs of computer equipment, which led to an increasing number of user types, and therefore user needs, which were met with new off-the-shelf software packages. Schools began to train people in GIS use. Technologies for digitization of information were little improved from the 1960's, and Tomlinson calls the 1970's a "decade of consolidation rather than innovation ... of widely dispersed need for GIS capabilities met by ad hoc system development" (Ibid: 23).

Joseph Berry (1993) has written a history of GIS that adds another interesting angle. Here he discusses the limitations of written maps, and suggests that the pre-GIS analysis of mapped natural resource data in the 1960's led to a fundamental shift in the long history of Western map use, and set a trajectory toward an entirely new endeavor: prescriptive mapping.

Our historical perspective of maps is one of accurate location of physical features primarily for travel through unfamiliar areas. Early explorers used them to avoid angry serpents, alluring sirens, and even the edge of the earth. The mapping process evokes images of map sheets and drafting aids such as pens, rub-on shading, rulers, planimeters, dot grids, and acetate transparencies for light-table overlays - sort of a Keystone Cops comedy of cartographic processing. From this perspective, maps are analog mediums composed of lines, colors, and symbols that are manually created and analyzed. Because manual analysis is difficult and limited, the focus of the analog map and manual processing has been descriptive, recording the occurrence and distribution of landscape features.

Most recently, the analysis of mapped data has become an integral part of resource and land planning. By the 1960's manual procedures for overlaying maps were common. These

techniques marked a turning point in the use of maps, from techniques that emphasize the physical descriptors of geographical space to those that spatially characterize management actions. *This movement from descriptive to prescriptive mapping sets the stage for computer-assisted map analysis.* (Berry, 1993: 203, emphasis added)

Seen from this perspective, the potentially powerful cartographic map has the capacity to become even more powerful, as its information becomes subject to an awesome analytical and integrative tool: the computer. Berry elaborates further on the fundamental limitations of manual cartography on the one hand, and statistics on the other hand, which, combined with the increasing needs for more sophisticated analysis of map data, led to the breakthroughs in, and widespread use of, GIS as we know it today.

Manual cartography techniques allow manipulation of these detailed data yet they are fundamentally limited by their non digital nature. Traditional statistics and mathematics are digital, yet they are fundamentally limited by their generalization of data. Such was the dilemma a decade ago. This dichotomy has led to the revolutionary concepts of map structure, content, and use that form the foundation of GIS technology. It radically changes our perspective: maps move from analog images describing the distribution of features to geographically referenced digital data quantifying a physical, social, or economic system in prescriptive terms. (Ibid: 204)

While prescriptive modeling is just one of the potential applications of GIS, the evolution beyond analog, descriptive images has changed forever the nature, power, and potential of maps. Berry stresses that to fully understand the power of GIS is to understand the significance of information digitization: "This revolution is founded in the recognition of the digital nature of computerized maps - maps as data, maps as numbers" (Ibid: 65, emphasis added). Computers are able to represent spatial data in the form we call a "map," but fundamentally, the computer holds and reads spatial data in digital form, which allows it to analyze, manipulate, and coordinate data sets in ways that often would take significantly longer done manually, if it could be so done at all.

The 1980's and 1990's have seen a dramatic expansion not only in the number of users of GIS, but also in the types of real-world applications for GIS. The advent of powerful personal computers and software packages designed for the layperson have brought GIS from the realm of the researcher and government to a variety of businesses, local communities, environmental, and indigenous groups. Planners, insurance companies, real estate agents, marketers, academic departments, and governments on many levels use GIS for a wide range of purposes, expanding greatly on the original purpose for which GIS was created - to translate cartographic maps into a computer analyzable form.

One of the largest GIS software producers is Environmental Systems Research International, (ESRI), located in Redlands, California. Its ARC/INFO GIS software is used extensively in government, business, academia, and by many indigenous peoples. Its software packages are a good example of the distinctions in functionality and power that exist in the GIS world today. A workstation software license for ARC/INFO costs approximately \$15,000 for the first year, and less after that, and allows an

enormous range of data conversion, data manipulation, data coordination and data rendering options. This is a "top of the line" product, and is what is used by the City of Honolulu, the State of Hawai'i, and the Office of Hawaiian Affairs. ARC/INFO requires substantial training, and is said to be very complex and difficult to learn. ARC/INFO for PC costs several thousand dollars per year, also requires substantial training, and allows the user to do less than at a full workstation, but is a formidable GIS program with a wide range of applications. ARC/VIEW has been touted as the embodiment of GIS democratization, as it costs less than \$1,000, and can be run on most personal computers. However, it is primarily a tool for rendering and displaying data layers, without a capacity for the wide range of applications for which ARC/INFO was created.

"Democratization of GIS" rhetoric should not be taken as meaning that suddenly all groups have the GIS power that government agencies or many businesses have. There is significant variation in what GIS can actually mean and what it can be used for - from simple single layer map production and rendering, to interface and query of massive databases for policy, academic or marketing research, to decision support modeling, to land management and other forms of sophisticated data analysis. This variation in users and applications depends on access to different tools and software designed for different purposes: ARC/INFO is on the expensive and training-intensive end; while CISIG, (Conservation International's GIS) which runs in English, Spanish, and Portuguese, and the program known as IDRISI are designed for basic GIS applications, user-friendliness, and minimal overall cost. The larger context and dynamics of GIS development for different groups and different purposes is an important subject that deserves more research, for it lies at the heart of the social history, social construction, social uses, and social implications of GIS.

We feel it important to emphasize the importance of the social history and social construction of GIS, and in doing so, we situate our research in the larger context of ontology, economy, and society, and the multiple voices that have something to say on the issue. By viewing a larger level of society and economy, more of GIS' origins and influences are revealed. The social and intellectual history of GIS is a history that needs to be told, though it is currently only in its early stages. A full social history requires original research that is beyond the scope of this thesis, and is currently being proposed by a whole team of scholars. (Jon Goss, personal communication)

Addressing social history in this paper we raise three questions, which we address to some extent in our theory, findings, and conclusion sections.

1. In what ways does GIS reflect and incorporate the particular biases and assumptions of Western scientific-industrial society?
2. How is the emergence of GIS related to the crises and transformation of capitalist economy and liberal state? To what extent can GIS be seen as an evolution of the tendency toward the computerization and automation of Western society?
3. What other voices and perspectives can be invoked to foster a more thorough understanding of the

origin, history, and current context of GIS?

4.3.2 Indigenous Peoples' Use of GIS

In this section we describe several relevant examples of indigenous use of GIS, and issues that indigenous people face in choosing and implementing GIS.

Peter Poole is a champion of empowering indigenous people to create solutions for their mapping and resource management needs with the most appropriate, inexpensive technologies available. Poole suggests that "GIS are useful at two levels: (1) as computer-based mapping programs capable of producing maps from locally acquired geocoded data; and (2) as advanced, analytical systems more appropriate for community umbrella or support associations." (Ibid: viii) Poole's survey (1995a), under the auspices of the Biodiversity Support Program (BSP) documents 63 indigenous initiatives that involve some form of low- or high-tech mapping, which are under local management. Poole focuses on six categories of indigenous mapping projects: 1) gaining recognition of land rights; 2) demarcation of traditional territories; 3) protection of demarcated lands; 4) gathering and guarding traditional knowledge; 5) management of traditional lands and resources; and 6) community awareness, mobilization, and conflict resolution.

GIS are being used to support tribes under duress, who find themselves in protracted legal battles over land and water rights. Addressing both tribes and lawyers, Brian Marozas (1991) writes about the use of GIS to support such tribes; how GIS has and may be used in indigenous groups' litigation, negotiation, and management of subsequent resources, based upon the inventory, analysis, and management of lands and resources.

One such indigenous group which has made extensive use of GIS in its recent and extensive land and financial settlement with the Canadian government is the Nisga'a. Tony Pearse writes about their process of negotiation in Aberley's Futures By Design.

Early in 1993 a team of Nisga'a land negotiators from northern British Columbia walked into an information exchange session with government officials in Victoria carrying only a black box the size of a shoeshine kit and a notebook computer. The box was a high-tech, interactive computer display device by which the operator could query a Geographic Information System (GIS) database and project the graphic results on a wall screen for immediate viewing. In a two-hour presentation, the Nisga'a team proceeded to dazzle their counterparts with a series of computer-generated slides that portrayed a variety of land and resource issues throughout different parts of their traditional territory. When the time for the government's presentation finally arrived, a rather beleaguered individual abashedly made his way to the wall and taped up a single, hand-drafted map for discussion. The contradiction was powerful, and its significance was not lost on the participants of the meeting. Probably for the first time in Canada, a local government, and in this case an aboriginal one, had challenged centralized government agencies in the "information

game," and had come out on top. To get here, however, has been a long road for the Nisga'a. (Aberley, 1994: 112)

Pearse writes that the Nisga'a started mapping the resource potential of the land in question in 1979, acquired a GIS in 1984, digitized their mapped data in 1990, and began utilizing satellite imagery with GIS in 1991. "[These] projects represent a natural evolution of an initial vision by Nisga'a leaders who foresaw that graphic representation and computing ability would be essential ingredients in dealing effectively with provincial government officials and private industrial developers" (Aberley, 1994: 115).

Eventual success aside, a major realization drives many of these efforts toward re-mapping: that the maps which exist often merely delineate the power and political abstractions of capitalist, consumerist, colonial forms of government, and thus most current maps are not very relevant to people who are more interested in wildlife, rainfall, watersheds, and opportunities for reinhabitation and sustainable management of the land. Modern maps, by what they reveal and what they hide, can conceal the fact that modern society's built environment is out of alignment with the patterns and cycles of the non-human world, and Turnbull (1993: 59) has pointed out that the power of maps is such that often the only thing that can challenge a map is another map.

The importance of maps to indigenous peoples is made clear in the introduction to the January 1995 Cultural Survival Quarterly "Geomatics" mapping issue, where Peter Poole (1995b: 1) writes that "More indigenous territory has been lost through maps than by guns." Bernard Nietschmann (1995: 37) suggests in the same issue that "This assertion has its corollary: more indigenous territory can be reclaimed and defended by maps than by guns." Poole (1995b: 1) states that "This collection of articles reflects how people from land based communities are using Geomatics in imaginative ways to address the question: how can we live off this land and keep it well?"

Some other titles in this issue include:

"The EAGLE Project: Remapping Canada from an Indigenous Perspective"

"Towards Information Self-Sufficiency: Nunavik Inuit Gather Information on Ecology and Land Use"

"Defending the Miskito Reefs with Maps and GPS"

"GIS and Long Range Planning for Indigenous Territories"

"Geomatics and Political Empowerment: The Yuqui"

"Gendered Resource Mapping: Focusing on Women's Spaces in the Landscape"

"Heirs to the Land: Mapping the Future of the Makalu-Barun"

"Community-Based Mapping in Southeast Asia."

As the titles suggest, many native peoples are using mapping technologies to define, steward, and defend their territories. Certainly those mentioned are just a few examples of a growing trend of native people using technology to serve their needs, instead of the other way around. Groups in Canada are using GIS to ready for land claims, for tracking environmental contaminants, and to assess distribution of natural

resources in service of long-range planning (Bird 1995: 24).

Canada's Assembly of First Nations states that, "An ultimate goal is to assist communities in taking control of their own data management by demonstrating and teaching them how to use technology (contemporary tools) while maintaining traditional knowledge (thus maintaining and/or re-learning the traditional way of life)" (Ibid: 24).

Poole suggests, however, that while indigenous groups are often enthusiastic about GIS when introduced to it, their eventual systems are frequently underutilized.

The study found wide interest in GIS, but only a few groups have so far used this technology to its fullest extent. There are accounts of technological overkill; vendors at a recent GIS conference in Vancouver estimated that 80% of the systems obtained by First Nations groups are not being properly utilized. Various reasons were cited for this -- lack of follow-up service, lack of initial training, and hidden and incremental costs. Many of the First Nations groups who are successfully applying the more sophisticated GIS have had to accept the cost of hiring full-time operators. Evidently, there are often mismatches between GIS capabilities and local capacities. (Poole, 1995a: 9, 11)

Jhon Goes In Center, of "Innovative GIS Solutions, Inc.," has told us that he has been working through his consulting practice and through seminars and workshops to educate indigenous peoples of the importance of cultural integration of GIS, and of not being technologically oversold. He asserted that his round table discussions on such subjects for indigenous people at the annual "GIS World" conference in Vancouver have been a success, and are growing significantly each year (Goes in Center, personal communication).

The use of GIS by indigenous people is not a subject that has received extensive treatment in any body of literature, and it is understandable that indigenous groups might be reticent about publishing extensively on their proprietary systems and databases. More informal networks of communication and information exchange exist, we have heard and have surmised, (Jhon Goes in Center, personal communication), however since we have not had a chance to explore or been invited to these networks, we do not have extensive knowledge of further examples of GIS use by indigenous peoples.

With this background of theory and literature context, methodology, and historical and contextual overview, we are now ready to describe our ethnographic findings. In the following section we relate our experiences first with the Nation of Hawai`i, then with GIS at two levels of Hawaiian government, and finally from interviews with three initiatives concerned with public access to GIS.

<-- [3. METHODOLOGY](#)

[CONTENTS](#)

[5. NATION OF HAWAII](#) --

[REFERENCES](#)

>

Shop in **Musical Instruments** (Beta-What is this?) | **amazon.com** | VIEW CART | WISH LIST | YOUR ACCOUNT | HELP

WELCOME | YOUR STORE | **BOOKS** | APPAREL & ACCESSORIES | ELECTRONICS | TOYS & GAMES | MUSIC | CELL PHONES & SERVICE | SEE MORE STORES

Search | Browse Subjects | Bestsellers | Magazines | Corporate Accounts | e-books & docs | New & Used Textbooks | Used Books

Search: Browse:

You clicked on this item...



The Discarded Image

by [C. S. Lewis](#)

Average Customer Review:
 Usually ships in 24 hours

Price: \$11.89
You Save: \$5.10 (30%)

29 used & new from **\$7.95**



Eligible for **FREE Super Saver Shipping** on orders over \$25. [See details.](#)

Synopsis

C. S. Lewis's *The Discarded Image* paints a lucid picture of the medieval world view, as historical and cultural background to the literature of the middle ages and renaissance. It describes the 'image' discarded by later ages as 'the medieval synthesis itself, the whole organisation of their... [Read more](#)

Or [buy used](#): **\$7.95**

You may also be interested in these items...

[Customers also shopped for](#)

Show items from:

- All Products**
- [Books](#) (18)
- [DVD](#) (11)
- [Music](#) (3)

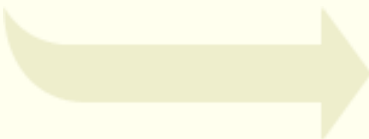

 <u>Studies in Medieval and Renaissance Literature (Canto)</u> by C. S. Lewis 	 <u>Studies in Words (Canto)</u> by C. S. Lewis 	 <u>An Experiment in Criticism (Canto)</u> by C. S. Lewis
 <u>Preface to Paradise Lost</u> by C. S. Lewis 	 <u>Till We Have Faces</u> by C. S. Lewis 	 <u>On Stories</u> by C. S. Lewis

	 Present Concerns by C. S. Lewis More like this	 Of Other Worlds by C. S. Lewis More like this	 God in the Dock by C. S. Lewis, Walter Hooper More like this
--	---	---	---









[More results](#) ▶

<p>New at Amazon.com Visit our new Seasonal Tableware Store and save up to 40% on Lenox, Spode, and more.</p>	<p>\$25 Off Tools & Hardware Take \$25 off when you spend \$199 or more on Tools & Hardware products offered by Amazon.com. Here's how (restrictions apply).</p> <p style="font-size: 2em; color: orange; font-weight: bold;">\$25 Offer</p>	<p>New at Amazon.com</p>  <p>Find more than 600,000 china, crystal, and silver products in the Replacements, Ltd. Store.</p> <p>REPLACEMENTS, LTD.</p>
---	--	---

<p>Where's My Stuff?</p> <ul style="list-style-type: none"> Track your recent orders. View or change your orders in Your Account. 	<p>Shipping & Returns</p> <ul style="list-style-type: none"> See our shipping rates & policies. Return an item (here's our Returns Policy). 	<p>Need Help?</p> <ul style="list-style-type: none"> Forgot your password? Click here. Redeem or buy a gift certificate. Visit our Help department.
--	--	---

Search for

Your Recent History
[Learn More](#)

<p>Recently Viewed Products</p> <ul style="list-style-type: none">  Line of Position Navigation by Michel Vanvaerenbergh  Secrets of the Viking Navigators by Leif K. Karlsen  The Sextant Handbook by Bruce Bauer  Taking the Stars by Peter Ifland  Navigation in the Age of Discovery by Duane A. Cline 	<p>Customers who bought items in your Recent History also bought:</p> <div style="display: flex; justify-content: space-around;"> <div style="text-align: center;">   The Complete On-Board Celestial Navigator by George C. Bennett </div> <div style="text-align: center;">   Latitude Hooks and Azimuth Rings by Dennis Fisher </div> </div>
--	---

▶ [Visit the Page You Made](#)

Turn your past books purchases into \$\$\$
[Learn more about selling at Amazon.com today!](#)

[Top of Page](#)

[Books Search](#) | [Browse Subjects](#) | [Bestsellers](#) | [Magazines](#) | [Corporate Accounts](#)

[e-Books & Docs](#) | [Bargain Books](#) | [Used Books](#)

[Amazon.com Home](#) | [Directory of All Stores](#)

Our International Sites: [Canada](#) | [United Kingdom](#) | [Germany](#) | [Japan](#) | [France](#)

[Contact Us](#) | [Help](#) | [Shopping Cart](#) | [Your Account](#) | [Sell Items](#) | [1-Click Settings](#)

[Investor Relations](#) | [Press Releases](#) | [Join Our Staff](#)

[Conditions of Use](#) | [Privacy Notice](#) © 1996-2004, Amazon.com, Inc. or its affiliates

New URL: www.walter-fendt.de/a14e (Java 1.4)

www.walter-fendt.de/a11e (Java 1.1)



[| Home](#) | [| Mailing Lists](#) | [| Bookstore](#) | [| Forums](#) | [| Weather](#) | [| Tide Predictions](#) | [| Bowditch](#) |

Bowditch -The American Practical Navigator

These files are in Adobe Acrobat format.



[Title Page](#)

[Preface](#)

[Chapter 1 Introduction to Marine Navigation](#)

[Chapter 2 Geodesy and Datums in Navigation](#)

[Chapter 3 Nautical Charts](#)

[Chapter 4 Nautical Publications](#)

[Chapter 5 Short Range Aids to Navigation](#)

[Chapter 6 Magnetic Compass Adjustment](#)

[Chapter 7 Dead Reckoning](#)

[Chapter 8 Piloting](#)

[Chapter 9 Tides and Tidal Currents](#)

[Chapter 10 Radio Waves](#)

[Chapter 11 Satellite Navigation](#)

[Chapter 12 Hyperbolic Systems](#)

[Chapter 13 Radar Navigation](#)

[Chapter 14 ECDIS and The Integrated Bridge](#)

[Chapter 15 Navigational Astronomy](#)

[Chapter 16 Instruments for Celestial Navigation](#)

[Chapter 17 Azimuths and Amplitudes](#)

[Chapter 18 Time](#)

[Chapter 19 The Almanacs](#)

[Chapter 20 Sight Reduction](#)

[Chapter 21 Navigational Mathematics](#)

[Chapter 22 Navigational Calculations](#)

[Chapter 23 Navigational Errors](#)

[Chapter 24 The Sailings](#)

[Chapter 25 The Navigation Process](#)

[Chapter 26 Emergency Navigation](#)

[Chapter 27 Navigation Regulations](#)

[Chapter 28 Global Maritime Distress and Safety System](#)

[Chapter 29 Position Reporting Systems](#)

[Chapter 30 Hydrography and Hydrographic Reports](#)

[Chapter 31 The Oceans](#)

[Chapter 32 Ocean Currents](#)

[Chapter 33 Waves, Breakers, and Surf](#)

[Chapter 34 Ice in The Sea](#)

[Chapter 35 Weather Elements](#)

[Chapter 36 Tropical Cyclones](#)

[Chapter 37 Weather Observations](#)

[Chapter 38 Weather Routing](#)

Glossary

[A](#) [B](#) [C](#) [D](#) [E](#) [F](#) [G](#) [H](#) [I](#) [JKL](#) [M](#) [N](#) [O](#) [P](#) [QR](#) [S](#) [T](#) [UVWXYZ](#)

Acronyms

[| Home | Mailing Lists | Bookstore | Forums | Weather | Tide Predictions | Bowditch |](#)

Astronomy Without a Telescope

[Chapter index in this window](#) — — [Chapter index in separate window](#)

This material (including images) is [copyrighted!](#). See my [copyright notice](#) for fair use practices.

Now that you have some feeling for the scales of time and space that astronomy encompasses and some of the difficulties caused by being Earth-bound (well, okay: solar-system bound!), let's take a look at what is up there in the sky beyond the clouds. In this chapter, you will learn where to find the key points on the night sky, how to use the coordinate system that astronomers use, how the Sun's position among the stars changes and how that affects the temperature throughout the year, and about the phases of the Moon and eclipses. At the end of chapter, you will learn about the motions of the planets among the stars. All of the things in this chapter, you can observe without a telescope---naked eye astronomy (note to Jesse Helms and Sen. Exon: that means astronomy without the use of a telescope). You just need to observe the objects carefully and notice how things change over time. The vocabulary terms are in **boldface**.

Next >

[Go to next section](#)

[Go to Astronomy Notes home](#)

last updated: 04 May 2001

[Is this page a copy of Strobel's Astronomy Notes?](#)

Author of [original](#) content: [Nick Strobel](#)



Search: Browse:

You clicked on this item...



The Stars

by [H. A. Rey](#)

Average Customer Review: ★★★★★
Usually ships in 24 hours



Eligible for **FREE Super Saver Shipping** on orders over \$25. [See details.](#)

Price: \$9.56
You Save: \$2.39 (20%)

84 used & new from **\$3.88**

Review

"The Stars is the best book available for its purpose. It is also a brilliant example of the combined use of art and writing in bringing science to the layman."

Or [buy used](#): **\$3.88**

You may also be interested in these items...

[Customers also shopped for](#)

Show items from:

▶ **All Products**

- [Books](#) (20)
- [Camera & Photo](#) (4)
- [Computer & Video Games](#) (5)
- [DVD](#) (19)
- [Electronics](#) (1)
- [Kitchen & Housewares](#) (1)
- [Music](#) (20)
- [Software](#) (6)
- [Toys & Games](#) (18)
- [Video](#) (3)

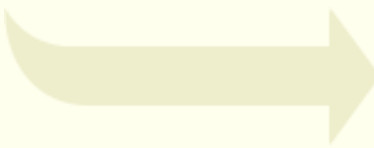

[Find the Constellations](#)

by H. A. Rey

[More like this](#)



[Glow-In-The-Dark Constellations](#)

by C. E. Thompson, Randy Chewning

[More like this](#)



[Nightwatch](#)

by Terence Dickinson

[More like this](#)



[Exploring the Night Sky](#)

by Terence Dickinson

[More like this](#)



[A Walk through the Heavens](#)

by Milton D. Heifetz, Wil Tirion

[More like this](#)



[The Book of Constellations](#)

by Robin Kerrod

[More like this](#)



Astronomy for All Ages, 2nd
by Philip Harrington, Edward Pascuzzi

[More like this](#)

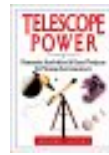

Telescope Power
by Gregory L. Matloff

[More like this](#)



The Night Sky 30°-40° (Large)
by David S. Chandler

[More like this](#)

[More results](#)

New at Amazon.com

Visit our new [Seasonal Tableware Store](#) and save up to 40% on Lenox, Spode, and more.

\$25 Off Tools & Hardware

\$25 Offer

Take \$25 off when you spend \$199 or more on [Tools & Hardware](#) products offered by Amazon.com. [Here's how](#) (restrictions apply).

New at Amazon.com



REPLACEMENTS, LTD.

Find more than 600,000 china, crystal, and silver products in the [Replacements, Ltd. Store](#).

Where's My Stuff?

- Track your [recent orders](#).
- View or change your orders in [Your Account](#).

Shipping & Returns

- See our [shipping rates & policies](#).
- [Return](#) an item (here's our [Returns Policy](#)).

Need Help?

- Forgot your password? [Click here](#).
- [Redeem](#) or [buy](#) a gift certificate.
- [Visit our Help department](#).

Search

for

Your Recent History

[Learn More](#)

Recently Viewed Products

- [The Discarded Image](#) by C. S. Lewis
- [Line of Position Navigation](#) by Michel Vanvaerenbergh
- [Secrets of the Viking Navigators](#) by Leif K. Karlsen
- [The Sextant Handbook](#) by Bruce Bauer
- [Taking the Stars](#) by Peter Ifland

Customers who bought items in your Recent History also bought:

- [The Complete On-Board Celestial Navigator](#) by George C. Bennett
- [Latitude Hooks and Azimuth Rings](#) by Dennis Fisher

[Visit the Page You Made](#)

Turn your past books purchases into \$\$\$
[Learn more](#) about selling at Amazon.com today!

[Books Search](#) | [Browse Subjects](#) | [Bestsellers](#) | [Magazines](#) | [Corporate Accounts](#)
[e-Books & Docs](#) | [Bargain Books](#) | [Used Books](#)

[Amazon.com Home](#) | [Directory of All Stores](#)

Our International Sites: [Canada](#) | [United Kingdom](#) | [Germany](#) | [Japan](#) | [France](#)

[Contact Us](#) | [Help](#) | [Shopping Cart](#) | [Your Account](#) | [Sell Items](#) | [1-Click Settings](#)

[Investor Relations](#) | [Press Releases](#) | [Join Our Staff](#)

[Conditions of Use](#) | [Privacy Notice](#) © 1996-2004, Amazon.com, Inc. or its affiliates

F1 - - Index of Selected Stars - (West to East) - - 05/17/01

The Nautical Almanac gives the location data for 173 stars, but from this listing 57 stars have been chosen from amongst these on account of brightness and distribution in the sky; they will suffice for the majority of observations. The location of a star is given by its sidereal hour angle (S.H.A.) and its declination (Dec.). The locations given below are rounded off to the degree of angle and are an aid in finding the star on a star chart, but for sight reduction, more precise values will be needed from the Nautical Almanac.

No.	Name	Mag.	S.H.A.	Dec.	No.	Name	Mag.	S.H.A.	Dec.
1	Alpheratz	2.2*	358	N.29	31	Gacrux	1.6	172#	S. 57
2	Ankaa	2.4	354	S.42	32	Alioth	1.7	167	N. 56
3	Schedar	2.5*	350	N.56	33	Spica	1.2*	159#	S. 11
4	Diphda	2.2	349#	S.18	34	Alkaid	1.9	153	N. 49
5	Achernar	0.6	336#	S.57	35	Hadar	0.9	149#	S. 60
6	Hamal	2.2*	328	N.23	36	Menkent	2.3	149	S. 36
7	Acamar	3.1	316	S.40	37	Arcturus	0.2*	146#	N. 19
8	Menkar	2.8	315	N. 4	38	Rigel Kentaurus	0.1	140#	S. 61
9	Mirfac	1.9*	309	N.50	39	Zubenelgenubi	2.9*	138#	S. 16
10	Aldebaran	1.1*	291#	N.16	40	Kochab	2.2	137	N. 74
11	Rigel	0.3*	282#	S. 8	41	Alpheca	2.3*	127	N. 27
12	Capella	0.2*	281	N.46	42	Antares	1.2*	113#	S. 26
13	Bellatrix	1.7*	279#	N. 6	43	Atria	1.9	108#	S. 69
14	Elnath	1.8	279	N.29	44	Sabic	2.6	103	S. 16
15	Alnilam	1.8*	276#	S. 1	45	Shaula	1.7	97#	S. 37
16	Betelgeuse	var.*	271#	N. 7	46	Rasalhague	2.1	96	N. 13
17	Canopus	-0.9	264#	S.53	47	Eltanin	2.4	91	N. 51
18	Sirius	-1.6*	259#	S.17	48	Kaus Australis	2.0	84#	S. 34
19	Adhara	1.6	256#	S.29	49	Vega	0.1*	81	N. 39
20	Procyon	0.5*	245#	N. 5	50	Nunki	2.1*	76#	S. 26
21	Pollux	1.2*	244	N.28	51	Altair	0.9*	63#	N. 9
22	Avior	1.7	234#	S.59	52	Peacock	2.1	54#	S. 57
23	Suhail	2.2	223	S.43	53	Deneb	1.3*	50	N. 45
24	Miaplacidus	1.8	222#	S.70	54	Enif	2.5	34	N. 10
25	Alphard	2.2	218#	S. 9	55	Al Na'ir	2.2	28#	S. 47

26	Regulus	1.3*	208#	N.12	56 Fomalhaut	1.3	16#	S. 30
27	Dubhe	2.0	194	N.62	57 Markab	2.6	14	N. 15
28	Denebola	2.2*	183#	N.15				
29	Gienah	2.8	176	S.17				
30	Acrux	1.1	174#	S.63				

* = Stars that are prominent for observers in the Northern hemisphere.

= Stars that are prominent for observers in the Southern hemisphere.

Var. = Variable star, mag. = 0.1 to 1.2

- Note that many stars are visible North and South of the equator.

[\[List in alphabetical order \]](#) - - - [\[HOME \]](#) - - - navtrig@yahoo.com

Is the altitude of Polaris equal to your latitude ?

Let us remind about the definition of Geographical Latitude "G.L." :

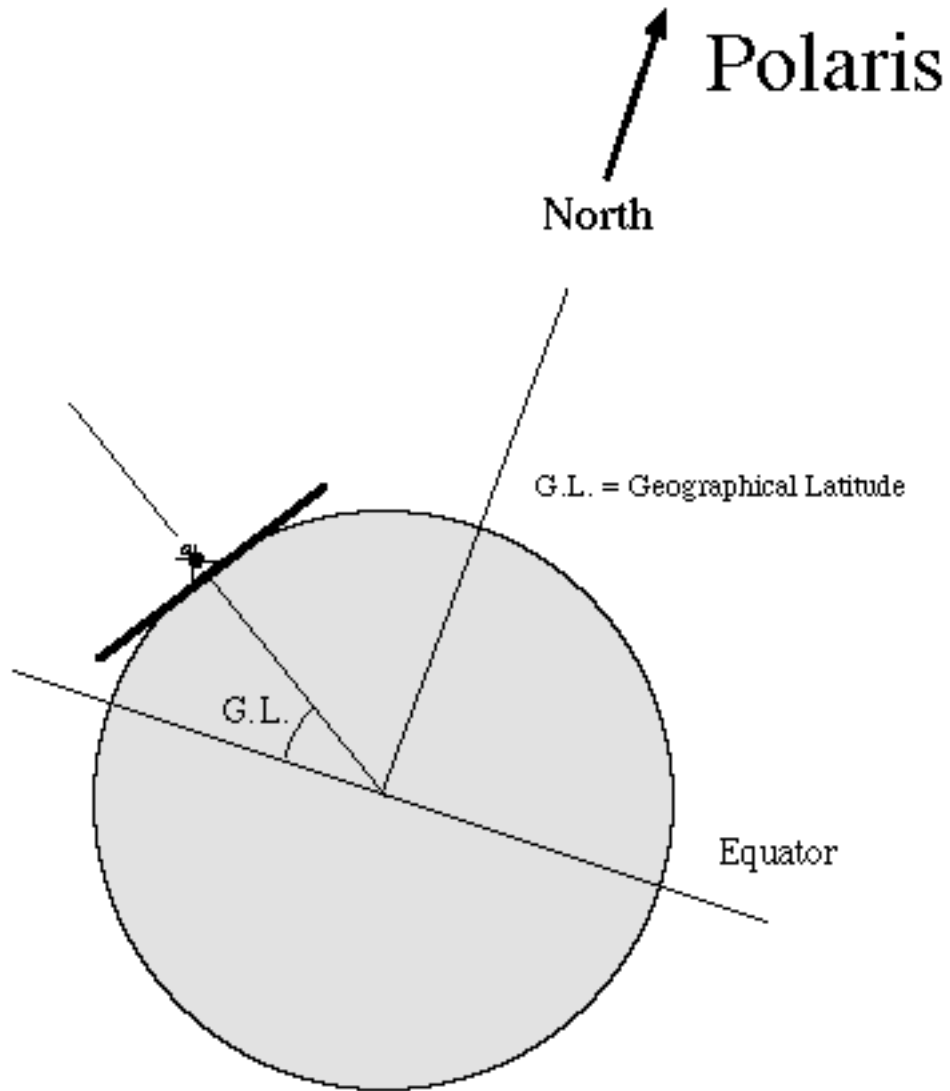

The North Star Polaris is to the upper right. In any math book - you may find drawings like below:

Two parallel Lines

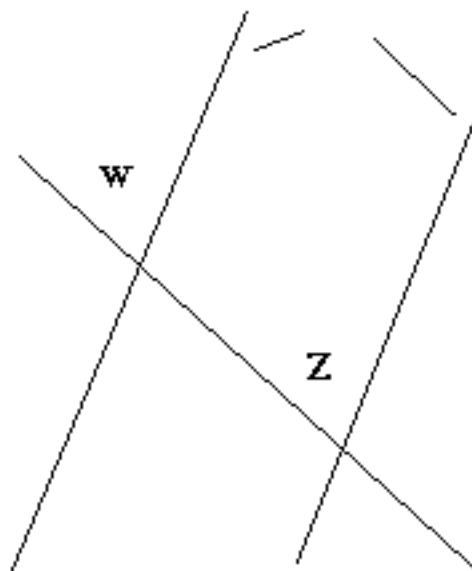

- telling that the angles W and Z are equal.

You may find these angles on the next figure too :

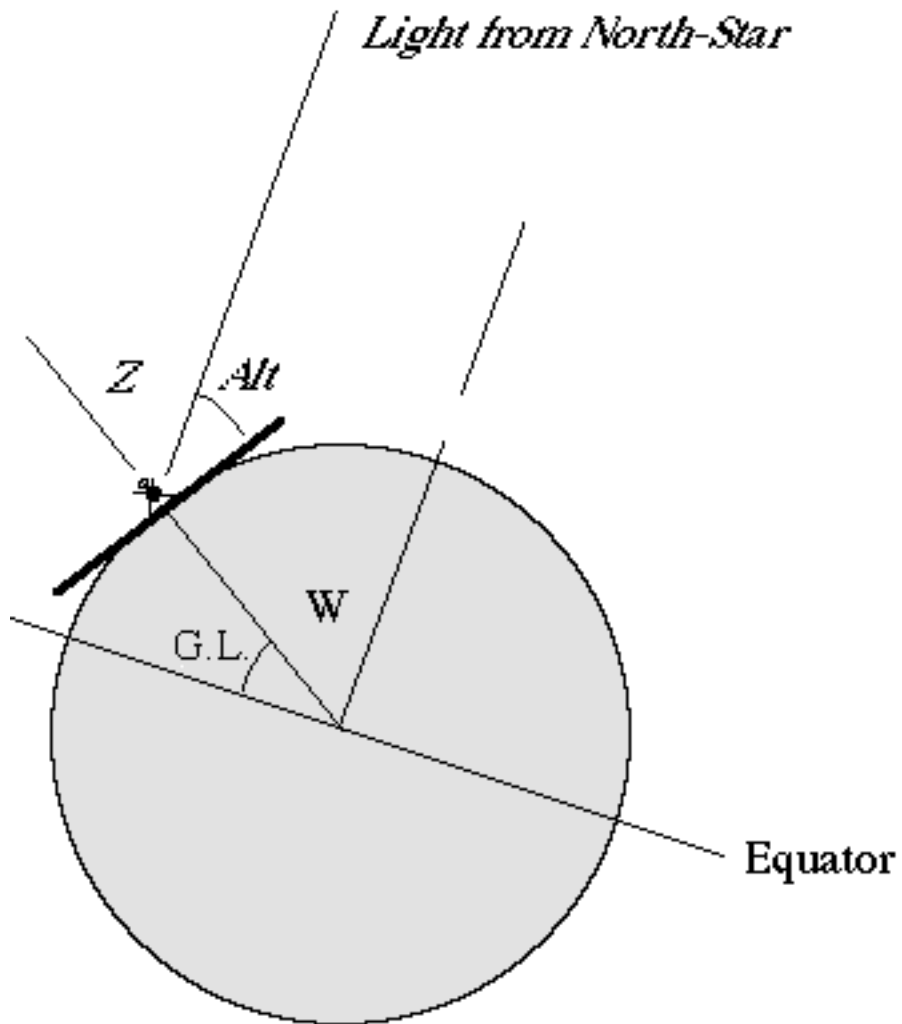

Comparing the angles gives again

$$Z = W$$

giving

$$90 - Z = 90 - W$$

- which gives

$$\text{Alt} = \text{Geographical Latitude}$$

So, we have demonstrated that the Altitude of Polaris above the horizon is equal to the observers' Geographical Latitude.

Celestial Navigation Example

Silicon Sea, leg 57

In these web pages, I will show an example of celestial navigation, step-by step. I have chosen as my example the sample [leg 57](#) from the sample problem series *Silicon Sea*

In this sample problem, we start with a boat whose last known position was $51^{\circ}30.0'S$, $80^{\circ}59.5'W$. We have the boat's heading and speed, and the current. After nearly a day of sailing, we take sextant sights on the moon and four stars. The goal of the exercise is to determine the boat's current position.

Tools

For the purposes of this exercise, we need the following items:

- Nautical Almanac for 1999.
- [Sight Reduction Tables](#).
- [Plotting Sheets](#)
- [Work Sheet](#)
- Compass or dividers
- Plotting ruler or drafting triangles
- Pens and pencils.

Steps

There are several steps to solving for our current position. Each is handled on its own page:

1. [Use dead reckoning to estimate current position](#)
2. [Prepare a plotting sheet](#)
3. [Compute line of position for Rigil Kentaurus](#)
4. [Compute line of position for Acrux](#)
5. [Compute line of position for Aldebaran](#)
6. [Compute line of position for Peacock](#)
7. [Compute line of position for the Moon](#)
8. [Final plot](#)
9. [Answering the questions in the exercise](#)
10. [Addendum -- solving with calculator instead of tables](#)

11. [Glossary](#)



The American Practical Navigator - Pub. 9 The American Practical Navigator, 2002

Current Edition:

Corrected through U.S. Notice to Mariners No.

38/2004 (18 September 2004)

This publication contains the following sections. Click the link to view a section on-line or download the file using your web browser's download mechanism. All documents are in **PDF format**. In order to view them on-line, you must have the Adobe Acrobat Reader© plug-in installed in your browser. For help on viewing/downloading, click [here](#).

Note

You may notice a chapter/filename mismatch for some chapters. This is a result of the elimination of former Chapter 29 and the subsequent renumbering of the remaining chapters. The original file names were retained to preserve the indexing links already built into the documents.

Download Entire Publication

[The American Practical Navigator](#) (37.62 Mb)

View/Download File

[Title Page](#) (19 kb)

[Front Matter](#) (323 kb)

[Table of Contents](#) (127 kb)

[Chapter 1 - Introduction to Marine Navigation](#)
(448 kb)

[Chapter 2 - Geodesy and Datums in
Navigation](#) (373 kb)

[Chapter 3 - Nautical Charts](#) (4.58 Mb)

[Chapter 4 - Nautical Publications](#) (597 kb)

[Chapter 5 - Short Range Aids to Navigation](#)
(710 kb)

[Chapter 6 - Compasses](#) (930 kb)

- [Chapter 7 - Dead Reckoning](#) (226 kb)
- [Chapter 8 - Piloting](#) (780 kb)
- [Chapter 9 - Tides and Tidal Current](#) (1.46 Mb)
- [Chapter 10 - Radio Waves](#) (406 kb)
- [Chapter 11 - Satellite Navigation](#) (327 kb)
- [Chapter 12 - LORAN Navigation](#) (547 kb)
- [Chapter 13 - Radar Navigation](#) (472 kb)
- [Chapter 14 - Electronic Charts](#) (286 kb)
- [Chapter 15 - Navigational Astronomy](#)
(4.1 Mb)
- [Chapter 16 - Instruments for Celestial
Navigation](#) (515 kb)
- [Chapter 17 - Azimuths and Amplitudes](#)
(179 kb)
- [Chapter 18 - Time](#) (1.24 Mb)
- [Chapter 19 - The Almanacs](#) (161 kb)
- [Chapter 20 - Sight Reduction](#) (2.92 Mb)
- [Chapter 21 - Navigational Mathematics](#)
(438 kb)
- [Chapter 22 - Calculations and Conversions](#)
(272 kb)
- [Chapter 23 - Navigational Errors](#) (169 kb)
- [Chapter 24 - The Sailings](#) (1.7 Mb)
- [Chapter 25 - Navigation Processes](#) (169 kb)
- [Chapter 26 - Emergency Navigation](#) (362 kb)
- [Chapter 27 - Navigation Regulations](#) (251 kb)
- [Chapter 28 - Maritime Safety Systems](#)
(678 kb)
- [Chapter 29 - Hydrography](#) (674 kb)
- [Chapter 30 - The Oceans](#) (665 kb)
- [Chapter 31 - Ocean Currents](#) (1.57 Mb)
- [Chapter 32 - Waves, Breakers and Surf](#)
(881 kb)
- [Chapter 33 - Ice Navigation](#) (2.93 Mb)
- [Chapter 34 - Weather Elements](#) (2.06 Mb)
- [Chapter 35 - Tropical Cyclones](#) (1.79 Mb)
- [Chapter 36 - Weather Observations](#) (2.52 Mb)

[Chapter 37 - Weather Routing](#) (1.12 Mb)

[Explanation of Navigational Tables](#) (113 kb)

[Table 1 - Logarithms of Numbers](#) (161 kb)

[Table 2 - Natural Trigonometric Functions](#)
(374 kb)

[Table 3 - Common Logarithms of
Trigonometric Functions](#) (333 kb)

[Table 4 - Traverse Tables](#) (764 kb)

[Table 5 - Natural and Numerical Chart Scales](#)
(15 kb)

[Table 6 - Meridional Parts](#) (54 kb)

[Table 7 - Length of a Degree of Latitude and
Longitude](#) (20 kb)

[Table 8 - Conversion Table for Meters, Feet
and Fathoms](#) (19 kb)

[Table 9 - Conversion Table for Nautical and
Statute Miles](#) (16 kb)

[Table 10 - Speed Table for Measured Mile](#)
(19 kb)

[Table 11 - Speed, Time and Distance](#) (33 kb)

[Table 12 - Distance of the Horizon](#) (16 kb)

[Table 13 - Geographic Range](#) (26 kb)

[Table 14 - Dip of the Sea Short of the Horizon](#)
(21 kb)

[Table 15 - Distance by Vertical Angle
\(Between Horizon and Top of Object\)](#) (24 kb)

[Table 16 - Distance by Vertical Angle
\(Between Waterline and Top of Object\)](#)
(26 kb)

[Table 17 - Distance by Vertical Angle
\(Between Waterline and Horizon\)](#) (19 kb)

[Table 18 - Distance of and Object by Two
Bearings](#) (36 kb)

[Table 19 - Table of Offsets](#) (18 kb)

[Table 20 - Meridian Angle and Altitude of a
body on the Prime Vertical](#) (31 kb)

[Table 21 - Latitude and Longitude Factors](#)
(41 kb)

[Table 22 - Amplitudes](#) (29 kb)

[Table 23 - Correction of Amplitude as Observed on the Visible Horizon](#) (18 kb)

[Table 24 - Altitude Factors](#) (51 kb)

[Table 25 - Changes of Altitude in Given Time From Meridian Transit](#) (30 kb)

[Table 26 - Time Zones, Zone Descriptions, and Suffixes](#) (19 kb)

[Tables 27 & 28 - Altitude Correction for Air Temperature and Pressure](#) (23 kb)

[Table 29 - Conversion Table for Thermometer Scales](#) (20 kb)

[Table 30 - Direction and Speed of True Wind in Units of Ship's Speed](#) (21 kb)

[Tables 31, 32 & 33 - Corrections to Barometric Reading](#) (19 kb)

[Table 34 - Conversion Table for Barometric Reading Units](#) (16 kb)

[Table 35 - Relative Humidity](#) (21 kb)

[Table 36 - Dew Point](#) (21 kb)

[Glossary](#) (4.03 Mb)

[Acronyms](#) (366 kb)

[Index](#) (791 kb)



[Publications Home](#)

[Maritime Safety Home Page](#)



If you have questions or comments pertaining to the information provided on this website or if you are experiencing technical difficulties, please contact: webmaster_nss@nga.mil

HTML last updated 24 Mar 2004

Shop in **Beauty** (Beta-What is this?) **amazon.com**   [VIEW CART](#) | [WISH LIST](#) | [YOUR ACCOUNT](#) | [HELP](#)

[WELCOME](#) | [YOUR STORE](#) | **BOOKS** | [APPAREL & ACCESSORIES](#) | [ELECTRONICS](#) | [TOYS & GAMES](#) | [MUSIC](#) | [CELL PHONES & SERVICE](#) | [SEE MORE STORES](#)

[Search](#) | [Browse Subjects](#) | [Bestsellers](#) | [Magazines](#) | [Corporate Accounts](#) | [e-books & docs](#) | [New & Used Textbooks](#) | [Used Books](#)

Search:

Browse:

You clicked on this item...



Latitude Hooks and Azimuth Rings

by [Dennis Fisher](#)

Average Customer Review: 
Usually ships in 24 hours



Eligible for **FREE Super Saver Shipping** on orders over \$25. [See details.](#)

Price: \$13.97
You Save: \$5.98 (30%)

9 used & new from **\$11.00**

Nautical Collector

"... for people who like to work with their hands and appreciate traditional nautical craftsmanship... Each project emphasizes simplicity and reasonable cost and is true to the spirit and function of the original instrument."

Or [buy used](#): **\$11.00**

You may also be interested in these items...

[Customers also shopped for](#)

Show items from:

 [All Products](#)

[Books](#) (20)

[DVD](#) (2)



The Sextant Handbook

by Bruce Bauer

[More like this](#)



The Complete On-Board Celestial Navigator

by George C. Bennett

[More like this](#)



Celestial Navigation in a Nutshell

by Hewitt Schlereth

[More like this](#)



Sundials

by Albert Edmund Waugh

[More like this](#)



Easy-to-Make Wooden Sundials

by Milton Stoneman

[More like this](#)



Sundials

by R. Newton Mayall, Margaret W. Mayall

[More like this](#)

	 Sundials by Hester Higton More like this	 Sundials by Rene R. J. Rohr More like this	 Celestial Navigation for Yachtsmen by Mary Blewitt More like this
--	--	---	--

[More results](#) 

<p>New at Amazon.com Visit our new Seasonal Tableware Store and save up to 40% on Lenox, Spode, and more.</p>	<p>\$25 Off Tools & Hardware Take \$25 off when you spend \$199 or more on Tools & Hardware products offered by Amazon.com. Here's how (restrictions apply).</p> <p style="font-size: 2em; color: orange;">\$25 Offer</p>	<p>New at Amazon.com</p> <div style="text-align: center;">  REPLACEMENTS LTD. </div> <p>Find more than 600,000 china, crystal, and silver products in the Replacements, Ltd. Store.</p>
---	--	---

<p>Where's My Stuff?</p> <ul style="list-style-type: none"> Track your recent orders. View or change your orders in Your Account. 	<p>Shipping & Returns</p> <ul style="list-style-type: none"> See our shipping rates & policies. Return an item (here's our Returns Policy). 	<p>Need Help?</p> <ul style="list-style-type: none"> Forgot your password? Click here. Redeem or buy a gift certificate. Visit our Help department.
--	--	---

Search **for**

Your Recent History
[Learn More](#)

<p>Recently Viewed Products</p> <ul style="list-style-type: none">  The Stars by H. A. Rey  The Discarded Image by C. S. Lewis  Line of Position Navigation by Michel Vanvaerenbergh  Secrets of the Viking Navigators by Leif K. Karlsen  The Sextant Handbook by Bruce Bauer 	<p>Customers who bought items in your Recent History also bought:</p> <div style="display: flex; justify-content: space-around;"> <div style="text-align: center;">   Find the Constellations by H. A. Rey </div> <div style="text-align: center;">   Studies in Medieval and Renaissance Literature (Canto) by C. S. Lewis </div> </div>
--	---

[Visit the Page You Made](#)

**Turn your past books purchases into \$\$\$
 Learn more about selling at Amazon.com today!**

[Books Search](#) | [Browse Subjects](#) | [Bestsellers](#) | [Magazines](#) | [Corporate Accounts](#)
[e-Books & Docs](#) | [Bargain Books](#) | [Used Books](#)

[Amazon.com Home](#) | [Directory of All Stores](#)

Our International Sites: [Canada](#) | [United Kingdom](#) | [Germany](#) | [Japan](#) | [France](#)

[Contact Us](#) | [Help](#) | [Shopping Cart](#) | [Your Account](#) | [Sell Items](#) | [1-Click Settings](#)

[Investor Relations](#) | [Press Releases](#) | [Join Our Staff](#)

[Conditions of Use](#) | [Privacy Notice](#) © 1996-2004, Amazon.com, Inc. or its affiliates



Pathfinding techniques for the prudent and inquisitive mariner

Emergency Navigation by David Burch

248 pages, 135 illustrations, paperback, published by McGraw Hill (1984) and now an International Marine Book Club selection.

June, 2004 -- This book is temporarily out of print. If you care to be placed on a waiting list, please send an email to Starpath with the request and we will let you know when it is available. [E-mail](#)

[Starpath](#) Requires a onetime-only anti-spam confirmation

\$16.95 ...item# 1830

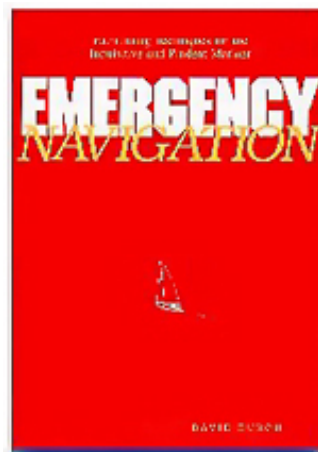

Emergency Navigation



Reviews



Contents

Once we have learned to navigate by conventional methods using all available equipment in all circumstances, the task of the prudent navigator reduces to learning about weather and how to navigate with only limited instruments or none at all. This book teaches the latter subject.

See Contents and Reviews links above for more info.

2003 Note. In the nineteen years now that this book has been published, we have not learned of techniques or principles that should be in it that aren't, nor do we have any reason to believe that anything in it is wrong - which we are happy to report (knock-on-wood.wav) since this book took some six years to write.

6/14/04

[|| home ||](#) [books index ||](#) [order help ||](#)

U.S. Naval Observatory

Astronomical Applications Department



Celestial Navigation Data for Assumed Position and Time

This page allows you to obtain all the astronomical information necessary to plot navigational lines of position from observations of the altitudes of celestial bodies. Simply fill in the form below and click on the "Get data" button at the end of the form.

A table of data will be provided giving both almanac data and altitude corrections for each celestial body that is above the horizon at the place and time that you specify. Sea-level observations are assumed. The almanac data consist of Greenwich hour angle (GHA), declination (Dec), computed altitude (H_c), and computed azimuth (Z_n). The altitude corrections consist of atmospheric refraction (Refr), semidiameter (SD), parallax in altitude (PA), and the sum $\text{Refr} + \text{SD} + \text{PA}$. The SD and PA values are, of course, non-zero only for solar system objects.

The assumed position that you enter below can be your best estimate of your actual location (e.g., your DR position); there is no need to round the coordinate values, since all data is computed specifically for the exact position you provide without any table lookup.

Data can be produced for any date and time from year 1700 through year 2035.

Be sure to check [Notes on the Data](#), located after the form.

Date and time of observation:

Use UT (Universal Time). Specifically, the program assumes UT1.

Year: Month: Day:
 Hour: Minute: Second: UT

Assumed position:

Enter best-estimate sea level coordinates.

Latitude: north south ° '
 Longitude: east west ° '

Notes on the Data:

Data are shown for the navigational stars and planets only if their computed geocentric altitude, H_c , is equal to or greater than +1 degree at the place and time specified. Almanac data for the Sun is shown if its H_c is greater than -12 degrees, the limit for nautical twilight (this is intended as an aid in judging the brightness of the sky). Almanac data for the Moon is shown if its H_c is greater than -3 degrees; when data for the Moon is shown, a note on its phase appears at the end of the table.

Data are shown for objects above the horizon without regard to whether observations of them are practical. For example, data for stars are shown for either day or night, and data for objects that may be too close to the Sun for observation are also shown.

The GHA of Aries is always shown at the end of the list of objects.

The data are color-coded as follows: Data for solar system objects are shown in red and always appear first in the table. Data for the stars that are listed in *Sight Reduction Tables for Air Navigation (Selected Stars)* ([Pub. No. 249](#), [AP3270](#), Vol. 1) are shown in blue providing that their H_c values are between 15 and 65 degrees; otherwise they are shown in black. Data for the other navigational stars are also shown in black. Data for Polaris and the GHA of Aries are shown in green.

The altitude corrections are intended for use during sight reduction. For a given object, to obtain the observed altitude (H_o), the sum of the altitude corrections (in the rightmost column) is added to the apparent altitude (h_a), which is itself obtained from the sextant altitude (h_s) by removing instrumental and dip (height of eye) corrections. That is, $H_o = h_a + \text{Sum}$. Then H_o can be compared to H_c to obtain the altitude intercept in the usual way. The altitude correction values strictly apply only in the case where the observations were in fact made from the assumed position, and, for solar system objects, the lower limb of the object was observed. Generally, however, these corrections are weak functions of altitude and can therefore be applied, with some small error, to sights made close to the assumed position. The first of the listed corrections, refraction, applies to sea level observations made under standard atmospheric conditions. The SD correction for the Moon includes augmentation.

The tabulated data can also be used for observation planning, where a prediction of the the apparent altitude (h_a) may be formed by subtracting the sum of the altitude corrections (in the rightmost column) from the computed altitude: h_a (predicted) = $H_c - \text{Sum}$. In many cases, the sum of the altitude corrections is negative, so that h_a (predicted) will be greater than H_c .

If you are having trouble seeing the date fields on this page, try the [version without JavaScript](#).

Back to [input form](#)

[[Publications](#) | [Data Services](#) | [Software](#) | [FAQ](#) | [Research](#) | [About AA](#)]
[[News](#) | [Site Map](#) | [Index](#) | [Home](#)]

[Need help?](#)

Last modified undefined NaN, NaN at NaN:NaN

This service generates "Nautical Almanac" like daily pages.

Date range: between 1950 and 2050

Parameter: initial date of a 3 day period.

Generated data includes:

- Star position table (SHA and declination).
- Sun and Moon hour tables, complete with increments and Semi diameter.
- Planets hour tables, with increments.
- Aries hour table.

A few tables are **not** included:

- Twilights, Sun and Moon rise and set.
- Sun E.T. and meridian passage.
- Moon meridian passage, age and phase.
- Correction tables (yellow pages) - Tables from an old Almanac can be used instead.

While not intended to substitute the Nautical Almanac, this information is enough to do celestial navigation using the traditional methods.

Other celestial navigation stuff in this site:

- > [Navigator Software](#) - Theory and practice in celestial navigation. Software for Windows.
- > [Navigator Star Finder](#) - Polar chart of the sky in a given time and position.

Questions? check Online Nautical Almanac [tips](#)

Date [mm/dd/yyyy] :

Navigator Light® Almanac Pages

<http://www.tecepe.com.br/nav>

(c)Copr 99-04 Omar Reis



NGA Digital Navigation Publications

Corrected through U.S. Notice to Mariners No.

38/2004 (18 September 2004)

Updates to a digital publication product or service are available for download as a ZIP file. To download, click on the link to store the file in the appropriate directory. The updates will be contained in the **Digital Update** column. If "Update Available" appears in this column, a new update file has been attached. This file represents new changes to be downloaded. For help on viewing/downloading, click [here](#).

Sight Reduction Tables for Air Navigation - Pub. 249

Volume	Title	Current Edition	Last NTM Applied	Digital Update
1	Vol. 1 (Selected Stars) 2000 Ed. (Epoch 2005.0)		04/2001	
2	Latitudes 0°—40° Declinations 0°—29°		46/1952	
3	Latitudes 39°—89° Declinations 0°—29°		46/1952	

[Publications Home](#)

[Maritime Safety Home Page](#)

If you have questions or comments pertaining to the information provided on this website or if you are experiencing technical difficulties, please contact: webmaster_nss@nga.mil

HTML last updated 24 Mar 2004



catalog

ACCESSORIES

[courses](#) [software](#) [books](#) [index](#)

2102-D Star Finder

plastic plates, 12" diameter, in sturdy case

\$37.00 ...item# 1841



2102-D Star Finder

The unit consists of a base plate (North Hemisphere on one side, South on the other), plus set of latitude plates. Use the [Nautical Almanac](#) to look up the GHA of Aries for the time of interest, then set the appropriate latitude disk on the base plate. Rotate the arrow on the latitude disk to the Local Hour Angle of Aries, and you have in your hand a complete (quantitative) picture of sky around you. From the disk you can read numerical locations of stars and planets, sun and moon — for example, the star Antares bearing 187° true and 25° above the horizon.

This is an invaluable device for celestial navigators, but also useful for more general star gazing. See related discussion under [The Star Finder Book](#), which describes in detail how to use this versatile device.



Note that all you need from the almanac is the GHA of Aries, and this can be obtained from a simple long-term almanac (a short list of numbers); the annual purchase of a Nautical Almanac is not required. Early editions of Bowditch, vol.II, contain such an almanac.

11/8/03

|| [home](#) || [accessories index](#) || [order help](#) ||

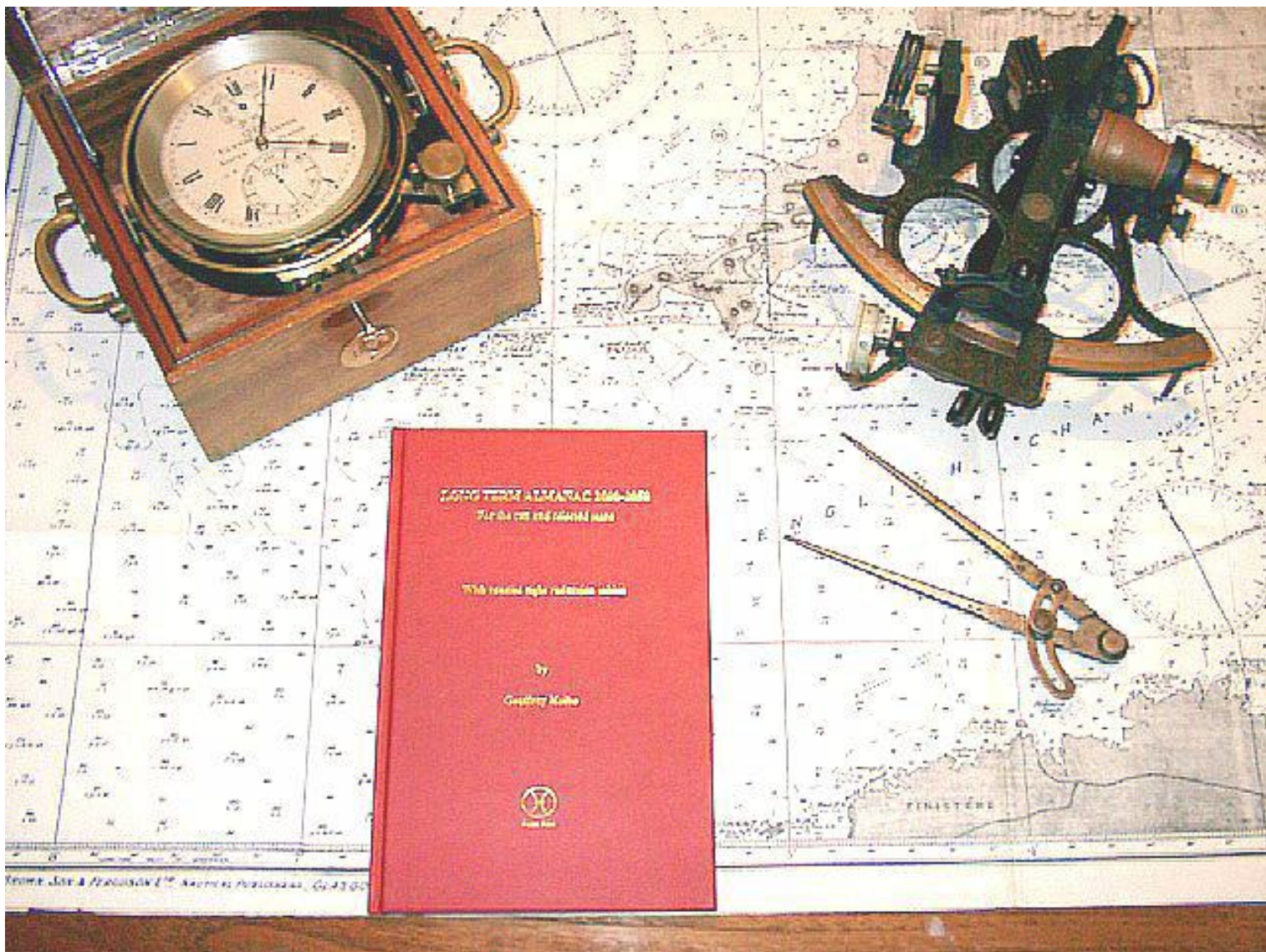

Long Term Almanac 2000 - 2050

As electronic systems become the principal means of navigation, celestial navigation is being relegated to a backup role. However, the usefulness (if not the necessity) of a celestial navigation backup capability makes attractive an almanac which is easily stowed and does not need annual replacement, thus avoiding the danger of it being out of date when needed.

Arrangement

The main body of the Almanac consists of Ephemerides from which the Greenwich Hour Angle (GHA) of the sun, the declination of the sun and the GHA of Aries may be determined for any time from the year 2000 to 2050.

OCTOBER									
DAY	GHA SUN	IRRELY ACCN	QUAD CORR	DEC SUN	IRRELY RATE	QUAD CORR	GHA ARIES		
01	18 33 34.7	+0.20	+0.09	3 13 37.8	+0.97	+0.73	10 02 11.2		
02	18 33 34.8	+0.20	+0.09	3 13 37.8	+0.97	+0.73	10 02 11.2		
03	18 33 34.9	+0.20	+0.09	3 13 37.8	+0.97	+0.73	10 02 11.2		
04	18 33 35.0	+0.20	+0.09	3 13 37.8	+0.97	+0.73	10 02 11.2		
05	18 33 35.1	+0.20	+0.09	3 13 37.8	+0.97	+0.73	10 02 11.2		
06	18 33 35.2	+0.20	+0.09	3 13 37.8	+0.97	+0.73	10 02 11.2		
07	18 33 35.3	+0.20	+0.09	3 13 37.8	+0.97	+0.73	10 02 11.2		
08	18 33 35.4	+0.20	+0.09	3 13 37.8	+0.97	+0.73	10 02 11.2		
09	18 33 35.5	+0.20	+0.09	3 13 37.8	+0.97	+0.73	10 02 11.2		
10	18 33 35.6	+0.20	+0.09	3 13 37.8	+0.97	+0.73	10 02 11.2		
11	18 33 35.7	+0.20	+0.09	3 13 37.8	+0.97	+0.73	10 02 11.2		
12	18 33 35.8	+0.20	+0.09	3 13 37.8	+0.97	+0.73	10 02 11.2		

These are based on the fact that approximately correct values for the position of the sun and the GHA of Aries may be obtained from any almanac that is exactly four years out of date. By applying quadrennial correction factors, an ephemeris for any given year may be used to determine the position of the sun and GHA of Aries to good

accuracy, exactly four years hence and multiples thereof.

The period of validity of these tables has been set at 50 years, that being the period for which simple, linear, quadrennial correction factors will still give good accuracy (about 0.3') for corrected table values.

Tables for the positions of 39 selected navigational stars, including Polaris, are given for the year 2000. Annual correction factors are also given to account

STAR	SHA			DECLINATION		
	MARCH	APRIL	ANN. COR.	MARCH	APRIL	ANN. COR.
Acemrae	315 26.4	315 26.5	-0.5737	S 40 18.6	S 40 18.4	-0.240
Achernar	335 34.8	335 34.9	-0.560	S 57 14.5	S 57 14.3	-0.305
Acub	173 20.1	173 20.1	-0.843	S 63 05.9	S 63 06.1	+0.330
Aldebaran	293 01.2	293 01.4	-0.860	N 16 30.5	N 16 30.5	+0.118
Alkaid	153 06.7	153 06.6	-0.600	N 49 18.6	N 49 18.7	-0.300
Alphard	218 05.9	218 06.0	-0.735	S 8 39.8	S 8 39.8	+0.260
Alphecca	126 19.7	126 19.5	-0.638	N 26 42.7	N 26 42.8	-0.230
Alpheratz	357 54.5	357 54.4	-0.778	N 29 05.3	N 29 05.2	+0.330

for their subsequent apparent motion, so that their positions may be calculated for any subsequent year.

Star charts showing the positions of the selected stars are also given. These stars are also shown in the context of prominent constellations and other stars.

As well as the usual tables for refraction and dip, concise tables for sight reduction are given. These tables may be used to compute a calculated altitude and azimuth from an estimated position. These tables should determine the altitude within one minute.

To order your book

You can order your book online using any popular credit card. The sale of the book will be handled by the "CCNow" e-commerce company. The sales price are given in US dollars. Just click on the price appropriate to the place where you live.

For those living in the UK, the price including Post and Packing is [\\$23](#)

For those living in Europe, the price including Post and Packing is [\\$24](#)

For those living anywhere else in the world, the price including Post and Packing is [\\$29](#)

CCNOW
our authorised online retailer

- Secure Online Shopping
- All Major Credit Cards



catalog

ACCESSORIES

[courses](#) [software](#) [books](#) [index](#)

StarPilot-86

Navigation Calculator for celestial and coastal piloting

[Also available for TI-89 and TI-92Plus](#)

— State of the art solution to ocean and coastal navigation in an economical hand-held device.



Size = 3.2" x 7.1" x 0.75"

Package includes a TI-86 programmable, graphing calculator with built in StarPilot-86 software. Includes printed copy of the StarPilot User's Guide, plus StarPilot CD (which contains program back-up, navigation articles and documents, and TI-86 calculator manual in pdf format).

- [List of features](#)
- [StarPilot-86 Menus and Examples](#)
- [PDF Map of menus](#)
- [Compare the 89 to the 86](#)
- [\(Enhancement details of 89 vs 86 version\)](#)



\$279, shipping weight 3 lbs.

...Item #1863



Tech Support

Accessories and Options are same as with the StarPilot-89

StarPilot does celestial sight reductions of all bodies using high-precision internal almanac, plus mathematical and graphic solutions for position fixes, great circle, rhumb line, traverse and composite sailings, all current problems, piloting solutions, and much more...including lunar distance method of finding GMT from the sky and a unique graphical [Sight Planner](#), and the new [Sight Analyzer](#) function that helps you get the most accurate results from a series of sights.

The StarPilot is the state of the art solution to ocean navigation, fully up-gradeable with free upgrades available via Internet download, easy to use operation from logical menu lists, plus illustrated User's Guide with practice exercises.

Options include: [StarPilot software alone](#) — if you already have a TI-86 or it is more convenient to buy one yourself rather than our shipping it — and [PC-TI Link cable](#) for those who already own a TI-86 and want to load the StarPilot into it. This or similar cable is needed to move sight data and plots between calculator and PC if you care to do that, and to install new releases if they might occur — although we do not anticipate any changes to the StarPilot-86 program.

The StarPilot calculator comes with a hard plastic protective cover, but if you want more protection for use underway, we also have available as an option a very durable [waterproof case](#) for the StarPilot... that floats.

New option from Starpath: if you have or find a TI-86, 89, or 92+ calculator and wish to have the StarPilot loaded into it, but you do not have the cable or wish to get involved in the process, then we can do it for you. Send us the calculator by insured carrier and we will install the program of your choice for the cost of the software (\$129) plus a service charge of \$25 and return shipping, and then ship it back to you ready to go. You can download the manual as a pdf file and print a hard copy if you like.

Or if you have experience with these things and wish to do it yourself, the latest software version can be downloaded by registered owners from the Starpath web site. [Download StarPilot](#).

For navigators outside of the US, we list here [Where to buy a TI calculators worldwide](#).

Buy a calculator locally and download the software for the most economical way to get the StarPilot working for you.

Check here to see a pdf version of the [Emergency Navigation Booklet](#) designed specifically for use with the StarPilot. This is available as a free download to interested navigators, or we have these available for purchase (\$2.50) on durable, waterproof paper. It is designed to fit in the Otter box.

StarPilot is a phenomenal program in a phenomenal calculator. The full calculator functions are available to you even with StarPilot installed — if you care to use them. If you don't, you just need 3 buttons to operate all of the navigation functions of the calculator. The software programming is by Dr. Luis Soltero, a professional scientist, programmer, and worldwide sailor. The program design is by David Burch, director of Starpath School of Navigation. The programmed routines have been tested at sea for several years, the approach to celestial navigation used has been tested underway for 20 years. This product is custom designed to meet the style, efficiency, and precision of the Starpath approach to celestial navigation. You will not find a better product for this application anywhere in the world, at any price.

For more information see: Article on [Calculators and Celestial Navigation](#) or read about actual [recent sights underway](#) analyzed with the StarPilot and related articles.

For those who have other uses for this powerful calculator besides ocean navigation, see [Complete description of the TI-86 calculator](#) — a site which includes the complete TI-86 Guide Book and FAQs. Again, for those who want only ocean nav functions, you can completely forget about these other details of the calculator. Just push the number key next to the function you want, as outlined in the [Menus and Examples section](#). The graphs and plots will pop up when you need them automatically, then go away when you are done. No calculator or computer knowledge is needed.

On the other hand... we do recommend that you know the [old-fashioned way of doing celestial](#) with paper and books before getting too committed to a super-convenient calculator solution. The StarPilot does a tremendous amount of work for us, and does it better than we can by hand, but it is important that we know what it is doing. The beauty of celestial navigation is its transparency. Done right, we can tell immediately when a fix is good, or when we might have made an error. If we do not use the calculator properly and understand what it is doing for us, we run the risk of losing this primary virtue of doing celestial in the first place. A little [Reminder!](#)

|| [order help](#) || [home](#) || [accessories index](#) ||

Sextant Errors And Corrections

Sextant Error

The sextant is a high precision instrument. As such it is to be handled with care as shocks can easily damage or alter its characteristics. When delivered new, it should be accompanied by a calibration certificate which specifies the reading error along its full scale. The arc covered by the lever is slightly over 60 degrees (hence the name sextant). And since the angle measured is twice that, the range of measurement is 120 degrees. The correction sheet should show errors lower than 0.1' of arc at all points along the arc (if it is not, then buy another sextant) except for a constant permanent offset which is adjustable but never actually 0 unless you are very lucky.

This offset error can be checked easily by sighting on a distant object (a bright star is strongly suggested, one can't find much further objects than these), or instead use the horizon. Adjust the cursor until the object and its mirror image are superimposed. The reading is the sextant permanent error. In the tradition of the old navigators, we say the error is "Off the arc" if negative (the sextant is reading low) and the error must be added to the reading. Or the error is "On the arc" (the sextant is reading high) and the error must be subtracted from the reading.

Why take a distant object? Well the image seen from the mirror and the direct image are about 150 mm (6 inches) apart and sighting on a not too distant object will cause a parallax error. If you don't want to use a star, at least use the sea horizon which is a few kilometers away.

Corrective terms

Now this is all very straightforward except for the fact that the sextant altitude is always wrong. Apart from the sextant error itself, which is always the same and the easiest to allow for, there are 5 other measurement errors which require compensation

1. First and most obvious, the horizon that you use is not parallel with the surface of the earth under you feet. and the higher up you are, the greater the error (because the further away is the horizon). Consequently, the measurement that you take is always larger than it should be. The formula to correct for this error depends on the

height of the eye above the surface of the sea. Unless you use a bubble sextant, in which case there is no error, but I defy anyone to use a bubble sextant on a small boat, with the boat motion, the bubble would appear to suffer from St Vitus's Dance.

This effect is called "The dip of the sea horizon" and is equal to:

$$\text{DIP} = 1.753\sqrt{H}$$

Where H is the height of eyes in metres, and DIP is the correction in minutes of arc. This correction is always subtractive.

2. Second, less obvious but just as important is the refraction effect of the atmosphere. This effect, like the dip, always makes the reading larger than it would be if the atmosphere did not exist. The effect is larger for low altitudes (reaching about 30' of arc horizontally. Since the sun has an apparent diameter of about 32' of arc, when we see it just reaching the horizon at sunset, in fact, in reality it has just disappeared, only the refraction effect makes it still visible to us). The atmospheric pressure and the temperature of the air affect this refraction to some degree, in fact, the effect is proportional to the air density and the following formula is the one I use for compensation:

$$\Delta = \frac{0.267 \frac{P}{T}}{\text{TAN} \left(\text{Alt} + \frac{4.848 \times 10^{-2}}{\text{TAN}(\text{Alt}) + 0.028} \right)}$$

The correction is in minutes of arc (and always subtractive)

P is the atmospheric pressure in millibars,

T is the air temperature in degrees Kelvin

Alt is the altitude in degrees.

This formula has been checked against the published figures in the Admiralty's Almanac, Brown's Almanac and Norie's tables. The agreement is better than 0.01' of arc for all altitudes between 7 and 90 degrees. and better than +/- 1' of arc between 7 and 0 degrees.

3. Thirdly, when observing the sun or the moon, it is impossible to judge accurately where the center is, what navigators do is make one edge just touch the horizon,

which edge it is depends on personal preferences and also the contrast (one may be easier to see than the other), the edges are called "limbs" in technical jargon, hence we talk of the sun lower limb, or the moon upper limb. The published tables in the almanac apply to the centre of the object, therefore if using the lower limb, you need to add 1/2 the diameter of the sun (or moon) to your measurement. Vice versa, if using the upper limb, you need to subtract a 1/2 diameter. the apparent size of the object will vary somewhat over the year , the 1/2 diameter values for the sun are listed at monthly interval, for the moon daily.

4. Fourthly, the parallax error needs to be compensated for. For the sun , the error is always less than 1' of arc and not worth bothering about, (all the other effects are imprecise, and with the boat moving constantly, just be lucky to get an answer within 2 or 3'). But if you use the moon, the effects can be quite large (almost as much as 1 degree). The parallax error is because the tables assume that the observer is at the centre of the earth. This means that an observer seeing the moon with its centre on the horizon (after allowing for the refraction correction) would be wrong to assume 0 degree since it means the angle is really the earth radius divided by the distance from the moon to the earth. This value is also published in the almanac under the name of HP (Horizontal parallax, not "Hewlett-Pakard"). The method is to first do the dip and refraction corrections to the measurement, call this the Observed Altitude (OA), then add $HP \times \cos(OA)$ to it. This correction is always additive as the angle measured from the surface of the earth is always less than that which would be seen from the centre.

5. Last, and also for the moon only, one may wish to compensate for "the augmentation of diameter" effect. this is due to the fact that the published 1/2 diameter is as seen from the centre of the earth. It is still valid when the moon is just rising or setting, but when it is close to overhead, the distance from us to the moon has been shortened by the radius of the earth. this causes the moon to appear slightly bigger than the published figure. (the maximum effect is about 0.3' of arc and I personally wouldn't bother with it). However, for the masochists among you, here is the corrective term:

$$d = \frac{D}{2} \cdot \left[\frac{\sin(OA) \cdot \sin(HP)}{1 - \sin(OA) \cdot \sin(HP)} \right]$$

Note also that there is a relation linking the moon 1/2 diameter and the horizontal parallax : $D/2 = 937 \sin(HP)$.

In Practice

If using sight reduction tables, like HO249 or whatever the name of the newer ones is. You will notice that the tables are tabulated for LHA varying in 30' increments. Similarly, the latitudes are also varying in 30' increments. When choosing your DR, since it is likely to be wrong in any case, then choose one with a latitude being an exact multiple of 30', and a longitude which when subtracted from the GHA of the celestial object, will also yield a LHA also a multiple of 30'. This way the interpolations are reduced to the minimum required.

Avoid using the moon, as you can see from above, it requires all sorts of corrections. Not a good thing if you are under pressure.

Another little detail to be aware of is when the declination of the sun changes sign, it is easy to miss it and keep thinking it is North when it is in fact south. Highlight your almanac when you first buy it so when you get to that particular page (March and September) the colouring will spring to your attention.

Learn to know the stars, they are easy to recognise, and the main ones are almost all in the plane of the ecliptic. Sirius (canis major) is so bright that if you know where to look, you can see it when it is still day light. So is Canopus. But even constellation such as Orion (the saucepan is what Australians commonly call it) can be useful, the 3 dimmer stars inside the square are straddling the equator, this means that no matter where you are on earth, the stars always rise exactly east and set exactly west, pretty handy to check what the compass error is. Besides stars are pretty and we should spend more time looking at them.

Celestial Navigation  Rhumb Line Formulas

- [USNO Time in Standard Time Zones](#)
- **MPEG3 delayed audio broadcast of [the USNO Master Clock Voice Announcer!](#)**

Because streaming audio is buffered, the audio time will be delayed (late) by up to 30 seconds from when it left the USNO Master Clock. You may be able to shorten the delay by setting buffering to 3 seconds in your media player.

- [USNO Master Clock Time Animated GIF Clocks](#)

[Requires compatible browser, see [details here](#) .

- [Converting from Universal Time](#)
- [Compute Local Apparent Sidereal Time](#)
- [Another Realtime Clock](#)

See also the [www.time.gov Time Display](http://www.time.gov)

[BACK TO Time Service Home PageTop](#)

A Short Guide to Celestial Navigation

Copyright © 1997-2004 Henning Umland



[Introduction & Tutorial](#)



[Freeware](#)



[Cool Links](#)



[Contact](#)



[Author's Note & Personal Stuff](#)



Visitors since May 20, 1997:

90914

Last update: July 15, 2004



Nautical Almanac — Commercial Edition

Published by Paradise Cay Publications, about 152 pages,
paperback.

\$24.95 ...item# 1844



Order



Covers Jan 1, 2003 to Dec 31, 2003

This is a complete copy of the official government edition. This book lists the "locations" of the sun, moon, stars, and planets for every day, hour, minute, and second of the year. Location, as used here, means the latitude (called declination) and longitude (called Greenwich Hour Angle) of the point on earth that is directly below these objects in the sky — this point is called the Geographic Position of the object. The almanac also includes several other tables needed for the practice of celestial navigation.

The Almanac is needed for the actual practice celestial navigation, but you do not need this to work the home study course on celestial navigation. In the home study course table sections are provided.

The Almanac is published once a year and it is most convenient to use an up to date copy. However, you can use an old copy for the sun and stars, with some corrections which are all explained in the book. For moon and planets, you must have a current edition.

The main reference for the content of this book is the US Naval Observatory. The USNO includes a web site that will compute the almanac data on line for any specific object, time, and date within the current year. See the [Starpath Celestial Resources](#) section for a list of services and see specifically the beautiful Celestial Navigation Data page. The Nautical Almanac is actually a joint publication of USNO and the British counterpart called Her Majesty's Nautical Almanac Office. We try to keep all of these frequently-changing reference links up to date in the Resources sections.

12/30/02

The EZ-Locate interactive page has moved...

Main Menu

- Home
- Contact Us
- FAQ
- News Archive
- News By Topic
- Recommend

Geocoding

- Products & Services
- Batch Geocoding
- ZIP11 ACG
- Postal Points
- The Eagle Geocoder
- Test Drive Eagle

EZ-Locate

- EZ-Locate Interactive
-
- About EZ-Locate
 - Using EZ-Locate
 - Getting Started
 - Trial Account
 - Download Area
 - Subscription
 - Lost Password

Site Search**Test Drive Eagle**

Test drive Tele Atlas' Eagle geocoding technology

Input an Address

The Eagle™ geocoder will match the address and return information about the location and a map to go with it.

Street Address:

e.g. 1405 Adams Drive
or Adams Drive & O'Brien Drive

City:

State:

Zip:

You may geocode up to 25 addresses for pre-purchase evaluation purposes via this Test Drive page. If you need to evaluate a larger quantity of addresses, please [sign up for a free EZ-Locate trial account \(which includes 100 free geocodes\)](#). Alternatively if you have decided to use our technology you can [purchase an EZ-Locate subscription](#)

EZ-Locate rates begin at just \$50 and can be pre-paid with a credit card on our secure [E-Commerce](#) site. [Click here](#) to learn more about EZ-Locate pricing.

All map images, underlying map data and geographic information used on this web site are owned and licensed by Tele Atlas. All Rights Reserved. By accessing this web site or downloading geographic information, you agree to the [license agreement](#)

Contact Sales at 1-800-765-0555
[Subscribe to our e-newsletter!](#)

©2003 Tele Atlas. All rights reserved



NGA Digital Navigation Publications

Corrected through U.S. Notice to Mariners No.

38/2004 (18 September 2004)

Updates to a digital publication product or service are available for download as a ZIP file. To download, click on the link to store the file in the appropriate directory. The updates will be contained in the **Digital Update** column. If "Update Available" appears in this column, a new update file has been attached. This file represents new changes to be downloaded. For help on viewing/downloading, click [here](#).

Sight Reduction Tables for Marine Navigation - Pub. 229

Volume	Title	Current Edition	Last NTM Applied	Digital Update
1	Latitudes 0°—15°, Inclusive		11/1971	
2	Latitudes 15°—30°, Inclusive		11/1971	
3	Latitudes 30°—45°, Inclusive		07/1971	
4	Latitudes 45°—60°, Inclusive		03/1971	
5	Latitudes 60°—75°, Inclusive		03/1971	
6	Latitudes 75°—90°, Inclusive		23/1970	

[Publications Home](#)

[Maritime Safety Home Page](#)

If you have questions or comments pertaining to the information provided on this website or if you are experiencing technical difficulties, please contact: webmaster_nss@nga.mil

HTML last updated 24 Mar 2004

Plotting Sheet

This is an example of a plotting sheet. These are purchased in large pads from a marine supply store. You may also download a [postscript version](#) or [fig version](#) if you like for practice purposes, although an 8½x11 plotting sheet is a poor substitute for a full-size commercial plotting sheet.

Scroll down for some [more information](#) about the plotting sheet.

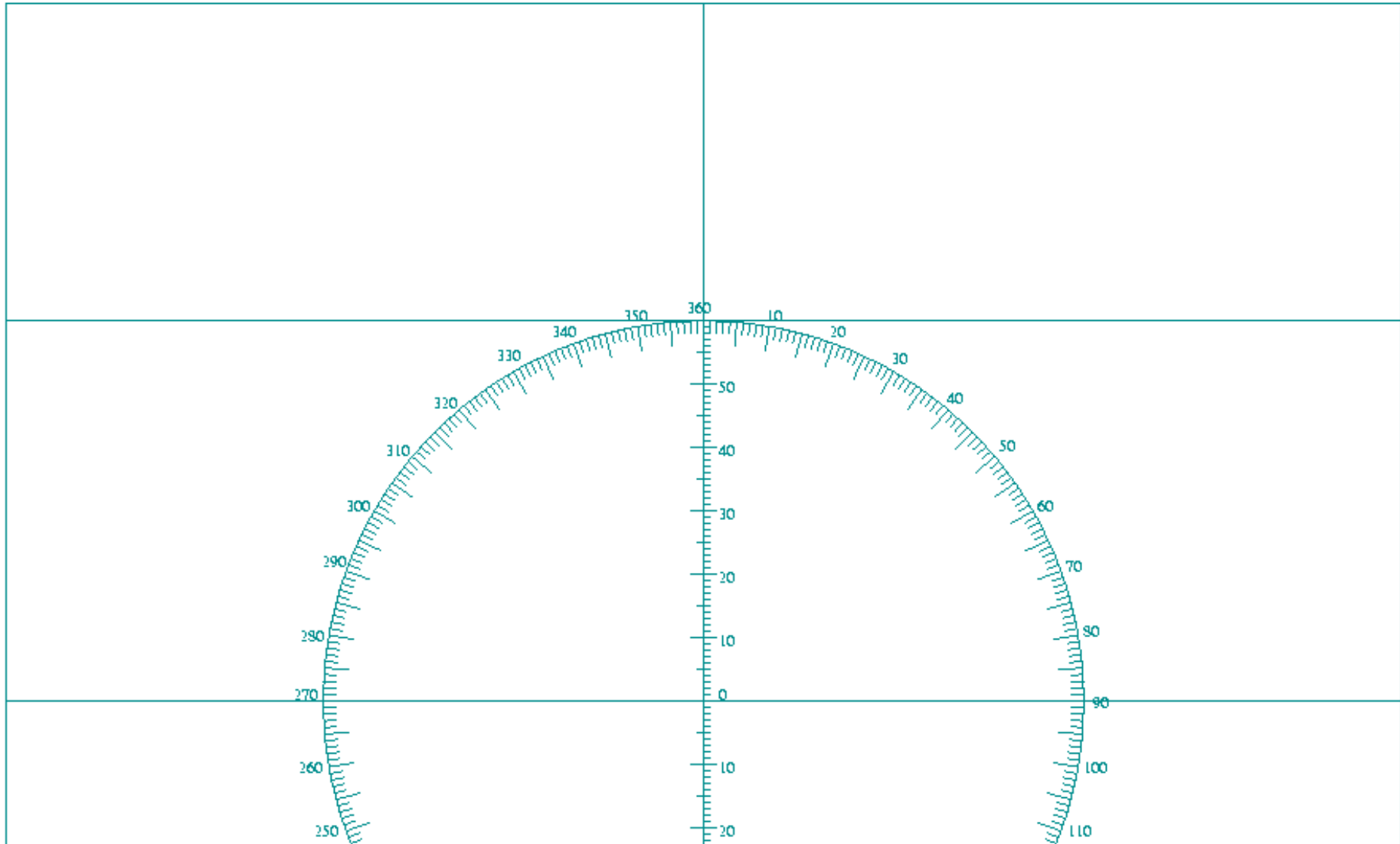

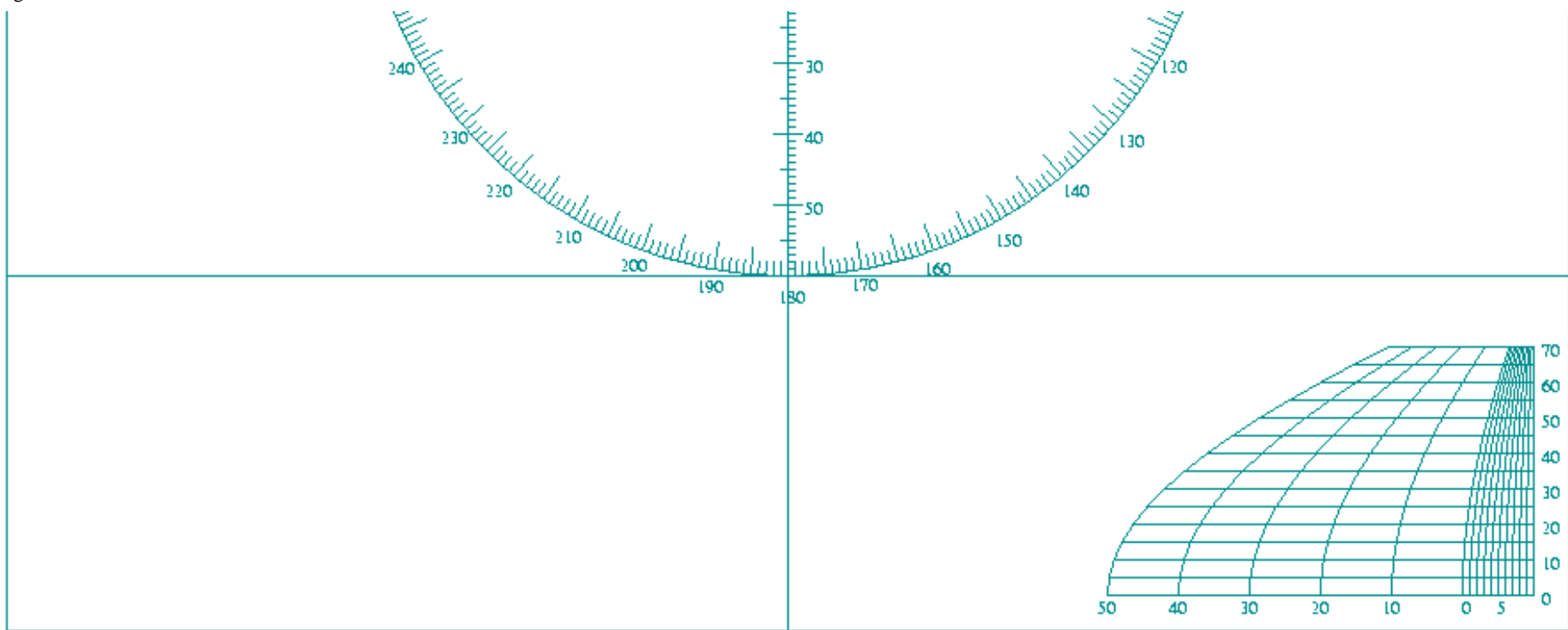

Compass Rose

The large circle in the center is obviously a compass rose, although it has other purposes as well. The scale of the plotting sheet is (normally) such that the radius of the compass rose is 60 nm.

Latitude Lines

The scale of the plotting chart is such that the distance between the horizontal lines is one degree of latitude. As you can see, the vertical line has been marked in one-minute increments. Also remember that one minute of latitude equals one nautical mile.

It's a good idea to mark the central latitude line with your working latitude

Longitude Lines

There are no other vertical lines since this chart is intended to be used at any latitude. At the equator, the longitude lines would have the same spacing as the horizontal lines. As you move away from the equator, the longitude lines are drawn progressively closer together.

The first thing you do when using a plotting sheet is to draw in some longitude lines. The easiest way to do this is to use the compass rose as your guide. Starting at the most horizontal points of the rose (90° and 270°), count up and down the number of degrees of your latitude. For example, when working at latitude 54° , you would count

up and down from the 90° and 270° points to find 36°, 144°, 216° and 324° respectively. Mark these points. Draw two vertical longitude lines through these two pairs. You now have a rectangular-projection map of your local area. Feel free to draw in some sea monsters and mermaids if it makes it look more like a map to you.

See [this picture](#) to see a plotting sheet with working lines added for latitude 54°.

Scale

This scale deserves some special attention. The plotting sheet is a map, and all maps need some scales. The marks on the central vertical line represent nautical miles (as well as minutes of latitude.) Measurements anywhere on the map may be made by using dividers to transfer distances to this scale.

This scale in the corner is used to measure minutes of longitude. To use, find your working latitude in the scale on the right edge and draw a horizontal line through the scale. Now, minutes of longitude may be measured along this horizontal line.

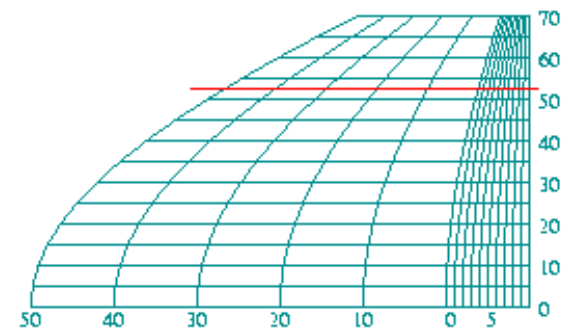

Object: _____

Hs: ____°__._
±ie ____._
-dip ____._
=Ha: ____°__._
±R0 ____._
=Ho: ____°__._

date, time: ____-__-__ __:__:__

almanac:

GHA: ____°__._ v: _____ decl: ____°__._ d: _____ HP: _____
+corr: ____°__._ +d: _____
+v: ____._ =decl: ____°__._
+SHA: ____°__._
=GHA: ____°__._
±AP: ____°__._
=LHA: ____°__._

Sight reduction table:

Hc: ____°__ d: _____ Z: ____°
+d: _____
=Hc: ____°__._
-Ho: ____°__._
=dist: ____._ +away, -towards

Freeware



Interactive Computer Ephemeris 0.51 (ICE) by U.S. Naval Observatory

This powerful DOS program calculates Greenwich hour angle and declination for Sun, Moon, planets, and the navigational stars with a precision equal to that given in the *Nautical Almanac*. ICE is very similar to the former *Floppy Almanac* but covers a time span of almost 250 (!) years. Rising, setting, and twilight times are also provided. It further performs sight reduction (including altitude corrections) for any assumed position. Beside its navigational functions, ICE provides highly accurate ephemeral data for astronomers. Results can be stored in an output file. ICE, predecessor of MICA (Multiyear Interactive Computer Almanac), is in the public domain now and no longer controlled or supported by *USNO*. This program is a must!

[Download ice.zip \(1 mb\)](#)

The Navigator's Almanac 2.0 by J. K. Simmonds

Another compact and user-friendly computer almanac. Creates and prints daily pages (interpolation tables required).

[Download almanac.zip \(63 kb\)](#)

JavaScripts

JavaScript is a nice language for programming scientific calculators. It is fairly easy to learn and

has a complete set of mathematical functions. The following utilities are interactive HTML documents containing JavaScript code. They have a user-friendly graphic interface (like Windows programs) and require much less space on the hard drive than stand-alone software. To run these programs, you need a web browser. One of the advantages of JavaScript is that browsers are available for most operating systems. Therefore, JavaScript programs are more or less platform-independent. The programs have been tested with Microsoft Internet Explorer 6 and Mozilla Firefox 0.9. Other browsers have to be checked individually.

Long Term Almanac for Sun, Moon, and Polaris 1.08 *by H. Umland*

A perpetual almanac for Sun, Moon, and Polaris. Calculates GHA, SHA, and Dec, GHA_{Aries} , and miscellaneous astronomical data. Requires current value for Delta T. To test the program click [here](#).

[Download longterm.zip \(14 kb\)](#)

Long Term Almanac for Sun, Moon, Brighter Planets and Polaris 1.12 *by H. Umland*

A perpetual almanac for Sun, Moon, Venus, Mars, Jupiter, Saturn, and Polaris. Calculates GHA, RA, Dec, and miscellaneous astronomical data. Requires current value for Delta T. This is an extended version of the above program. Since the uncompressed file is rather large (1.1 mb), starting the program from the hard drive is recommended.

[Download planets.zip \(340 kb\)](#)

Long Term Almanac for Moon, Stars, and Lunar Distances 1.11 *by H. Umland*

A perpetual almanac for the Moon and 58 bright stars including Polaris. Calculates GHA, SHA, and Dec for the Moon and a chosen star and the lunar distance of the star. In addition, GHA_{Aries} as well as HP, SD, and the phase of the moon are displayed. Requires current value for Delta T. To test the program click [here](#).

[Download staralm.zip \(13 kb\)](#)

Sight Reduction for the Sun 1.36 by *H. Umland*

A user-friendly sight reduction program for observations of the Sun. Includes 40-year almanac and altitude corrections. To test the program click [here](#).

[Download sunsight.zip \(8 kb\)](#)

Sight Reduction for the Moon 1.03 by *H. Umland*

A user-friendly sight reduction program for observations of the Moon. Includes 10-year almanac and altitude corrections. To test the program click [here](#).

[Download moonsght.zip \(8 kb\)](#)

Sight Reduction Calculator 1.49 by *H. Umland*

A compact sight reduction program. Includes altitude corrections. Requires GHA and declination from the *Nautical Almanac* or ICE. To test the program click [here](#).

[Download sightred.zip \(4 kb\)](#)

Fix Calculator 1.07 by *H. Umland*

A program calculating the point where two lines of position intersect. Replaces a graphic plot. To test the program click [here](#).

[Download fixcalc.zip \(3 kb\)](#)

RA to GHA Converter 1.02 by *H. Umland*

A utility calculating the GHA of a celestial body from right ascension and Greenwich sidereal time as provided by MICA (Multiyear Interactive Computer Almanac). To test the program click [here](#).

[Download ragha.zip \(2 kb\)](#)

Sight Reduction Tables *by H. Umland*

An extended version of Ageton's Tables in PDF format (90 pages). Includes instructions for use and a workform template.

[Download tables.zip \(650 kb\)](#)

A compact version of these tables (15 pages only) is also available.

[Download compact.zip \(334 kb\)](#)

Attention! If you downloaded an older version of the file compact.zip (dated before Jan 17, 2002), update it now. The old version contains a systematic error in one column of each page.

Other Stuff



Molecular Weight Calculator 1.06 *by H. Umland*

A JavaScript program for chemists and lab technicians. Calculates the molecular weight of a chemical substance. To test the program click [here](#).

[Download molwt.zip \(3 kb\)](#)

Disclaimer:

I provide the software on this page to you "as is" without any express or implied warranties of any kind including, but not limited to, any implied warranties of fitness for a particular purpose. I make no representations or warranties of any kind

with respect to any support services I may render to you. I do not warrant that the software will meet your requirements or that the operation of the software will be uninterrupted or error-free or that the software contains no defects or errors. You assume full responsibility for the selection, possession, performance, and proper installation and use of the software and for verifying the results obtained therefrom. You, the user, are solely responsible for determining the appropriateness of this software for your use and accept full responsibility for all risks associated with its use.



Home



Irbs.com

Navigation-1 Mailing List Archive

[| Home](#) | [| Mailing Lists](#) | [| Bookstore](#) | [| Forums](#) | [| Weather](#) | [| Tide Predictions](#) | [| Bowditch](#) |

Enter what you want to search for in the mailing list:

Browse the archive:

2004

September	22 messages
August	223 messages
July	257 messages
June	95 messages
May	270 messages
April	292 messages
March	257 messages
Februrary	261 messages
January	406 messages

2003

December	460 messages
November	177 messages
October	261 messages
September	162 messages
August	105 messages
July	126 messages
June	134 messages
May	150 messages

April	194 messages
March	220 messages
Februrary	218 messages
January	193 messages

2002

December	132 messages
November	91 messages
October	261 messages
September	172 messages
August	30 messages
July	47 messages
June	80 messages
May	57 messages
April	231 messages
March	143 messages
Februrary	241 messages
January	226 messages

2001

December	97 messages
November	67 messages
October	40 messages
September	35 messages
August	82 messages
July	204 messages
June	84 messages
May	61 messages
April	161 messages
March	31 messages
Februrary	64 messages
January	50 messages

2000

December	45 messages
November	44 messages

October	14 messages
September	72 messages
August	49 messages
July	47 messages
June	3 messages
May	121 messages
April	36 messages
March	21 messages
Februrary	46 messages
January	26 messages

1999

December	35 messages
November	14 messages
October	91 messages
September	51 messages
August	121 messages
July	107 messages
June	62 messages
May	44 messages
March	78 messages
Februrary	92 messages
January	46 messages

1998

December	12 messages
November	14 messages
October	36 messages
September	13 messages
August	1 messages
July	2 messages
June	4 messages
May	2 messages
January	3 messages

1997

December	3 messages
June	2 messages
May	14 messages
March	11 messages
Februrary	15 messages
January	2 messages

1996

December	5 messages
November	4 messages
October	8 messages
September	10 messages
August	15 messages

[| Home | Mailing Lists | Bookstore | Forums | Weather | Tide Predictions | Bowditch |](#)



amazon.com



VIEW CART

WISH LIST

YOUR ACCOUNT

HELP

- WELCOME
- YOUR STORE
- BOOKS
- APPAREL & ACCESSORIES
- ELECTRONICS
- TOYS & GAMES
- MUSIC
- CELL PHONES & SERVICE
- VIDEO
- SEE MORE STORES

- advanced search
- browse genres
- top sellers
- new & future releases
- kids & family
- movie showtimes
- today's deals
- used videos

SEARCH

WEB SEARCH

Powered by A9.com

Celestial Navigation Simplified (1992)

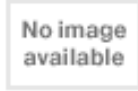

List Price: \$39.95
Price: **\$39.95** & This item ships for **FREE with Super Saver**
Shipping: [See details.](#)

Availability: Usually ships within 24 hours

12 used & new from **\$20.00**

Edition: **VHS**

[See more product details](#)

READY TO BUY?

or

[Sign in](#) to turn on 1-Click ordering.

MORE BUYING CHOICES

12 used & new from **\$20.00**

Have one to sell? [Sell yours here](#)

Welcome to **DVD & Video!**
[Click here](#) to explore more.

Top Sellers in Video:



1. [The Passion of the Christ](#)
2. [Laurie Berkner's Video Songbook](#)
3. [The Sound of Music](#)

Product Details

- **Starring:** [William F. Buckley Jr.](#), [William Buckley Jr.](#), [See more](#)
- **Format:** Color, NTSC
- **Rated:** NR
- **Studio:** Bennett Marine Video
- **Video Release Date:** January 1, 1992
- **VHS Features:**
 - **NTSC format (US and Canada only).** This VHS will probably NOT be viewable in other countries. Read more about [VHS formats.](#)
 - Color, NTSC
- **ASIN:** 6302138760
- **Amazon.com Sales Rank (VHS):** 28,532

Don't have one?
We'll set one up for you.

What's Your Advice?

Is there an item you'd recommend instead of or in addition to this one? Let the world know! Enter the item's ASIN ([what's an ASIN?](#)) in the box below, select advice type, then click Submit.

I recommend: _____ in addition to this video
 _____ instead of this video

Customer Reviews

Be the first person to review this [video!](#)

VIDEO INFORMATION

Explore This Video

[buying info](#)

[technical information](#)

RECENTLY VIEWED

Browse for **VIDEO** in:

- [VHS](#) > [Genres](#) > [Special Interests](#) > [Instructional](#) > [General](#)
- [VHS](#) > [Genres](#) > [Special Interests](#) > [Outdoor Recreation](#) > [Boats & Boating](#)
- [VHS](#) > [Genres](#) > [Special Interests](#) > [General](#)

 [Latitude Hooks and Azimuth Rings: How to Build and Use 18 Traditional Navigational Instruments](#) by Dennis Fisher

 [The Stars : A New Way to See Them \(Astronomy\)](#) by H. A. Rey

 [The Discarded Image : An Introduction to Medieval and Renaissance Literature \(Canto\)](#) by C. S. Lewis

 [Line of Position Navigation: Sumner and Saint Hilaire the Two Pillars of Modern Celestial Navigation](#) by Michel Vanvaerenbergh

► [See more in the Page You Made](#)

Featured Item:

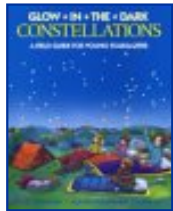

[Glow-In-The-Dark Constellations](#) by C. E. Thompson, Randy Chewing

- **I have seen this video, and I want to [review](#) it.**
- [E-mail a friend about this item.](#)
- [Write a So You'd Like to... guide.](#)
- [Check Purchase Circles.](#)

RATE THIS VIDEO

I dislike it I love it!

1 2 3 4 5

[Edit your ratings](#)

Favorite Magazines!



Subscribe to [entertainment magazines](#) today.

Visit the [Sports & Outdoors Store](#)



[Boating](#) equipment and apparel to help you set sail.

Suggestion Box

Your comments can help make our site better for everyone. If you've found something incorrect, broken, or frustrating on this page, let us know so that we can improve it. Please note that we are unable to respond directly to suggestions made via this form.

If you need help with an order, please [contact Customer Service](#).

Please mark as many of the following boxes that apply:

Product information is missing important details.

Product information is incorrect. Propose corrections using our [Online Catalog Update Form](#).

The page contains typographical errors.

The page takes too long to load.

The page has a software bug in it.

Content violates [Amazon.com's policy on offensive language](#).

Product offered violates [Amazon.com's policy](#) on items that can be listed for sale.

Comments or Examples:

Examples: Missing information such as dimensions and model number, typos, inaccuracies, etc.

Where's My Stuff?

- Track your [recent orders](#).
- View or change your orders in [Your Account](#).

Shipping & Returns

- See our [shipping rates & policies](#).
- [Return](#) an item (here's our [Returns Policy](#)).

Need Help?

- Forgot your password? [Click here](#).
- [Redeem](#) or [buy](#) a gift certificate.
- [Visit our Help department](#).





Search

for

Your Recent History

[Learn More](#)

Recently Viewed Products

-  [Latitude Hooks and Azimuth Rings](#) by Dennis Fisher
-  [The Stars](#) by H. A. Rey
-  [The Discarded Image](#) by C. S. Lewis
-  [Line of Position Navigation](#) by Michel Vanvaerenbergh
-  [Secrets of the Viking Navigators](#) by Leif K. Karlsen

Customers who bought items in your Recent History also bought:



-  [Find the Constellations](#) by H. A. Rey



-  [Studies in Medieval and Renaissance Literature \(Canto\)](#) by C. S. Lewis

▶ [Visit the Page You Made](#)

**Turn your past video purchases into \$\$\$
[Learn more about selling at Amazon.com today!](#)**

[Top of Page](#)

[Advanced Search](#) | [Browse Genres](#) | [Top Sellers](#) | [New & Future Releases](#)
[Kids & Family](#) | [Movie Showtimes](#) | [Bargain Outlet](#) | [Used Videos](#)

[Amazon.com Home](#) | [Directory of All Stores](#)

Our International Sites: [Canada](#) | [United Kingdom](#) | [Germany](#) | [Japan](#) | [France](#)

[Contact Us](#) | [Help](#) | [Shopping Cart](#) | [Your Account](#) | [Sell Items](#) | [1-Click Settings](#)

[Investor Relations](#) | [Press Releases](#) | [Join Our Staff](#)

[Conditions of Use](#) | [Privacy Notice](#) © 1996-2004, Amazon.com, Inc. or its affiliates



amazon.com



VIEW CART | WISH LIST | YOUR ACCOUNT | HELP

WELCOME

YOUR STORE

BOOKS

APPAREL & ACCESSORIES

ELECTRONICS

TOYS & GAMES

MUSIC

CELL PHONES & SERVICE

SEE MORE STORES

Search

Browse Subjects

Bestsellers

Magazines

Corporate Accounts

e-books & docs

New & Used Textbooks

Used Books

Search:

Browse:

You clicked on this item...

Practical Celestial Navigation

by Susan Peterson Howell

Out of Print--Limited Availability

6 used & new from \$18.15

buy used: \$18.15

You may also be interested in these items...

Show items from:

All Products

Books (2)

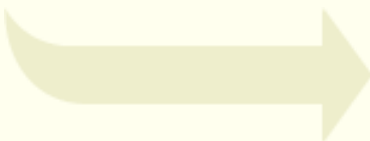

Celestial Navigation in a Nutshell

by Hewitt Schlereth

More like this



The Sextant Handbook

by Bruce Bauer

More like this

New at Amazon.com

Visit our new [Seasonal Tableware Store](#) and save up to 40% on Lenox, Spode, and more.

\$25 Off Tools & Hardware

\$25 Offer

Take \$25 off when you spend \$199 or more on [Tools & Hardware](#) products offered by Amazon.com. [Here's how](#) (restrictions apply).

New at Amazon.com



REPLACEMENTS.LTD.

Find more than 600,000 china, crystal, and silver products in the [Replacements, Ltd. Store](#).

Where's My Stuff?

- Track your [recent orders](#).
- View or change your orders in [Your Account](#).

Shipping & Returns

- See our [shipping rates & policies](#).
- [Return](#) an item (here's our [Returns Policy](#)).

Need Help?

- Forgot your password? [Click here](#).
- [Redeem](#) or [buy](#) a gift certificate.
- [Visit our Help department](#).





Search

for

Your Recent History

[Learn More](#)

Recently Viewed Products

-  [Celestial Navigation Simplified](#) VHS ~ William F. Buckley Jr.
-  [Latitude Hooks and Azimuth Rings](#) by Dennis Fisher
-  [The Stars](#) by H. A. Rey
-  [The Discarded Image](#) by C. S. Lewis
-  [Line of Position Navigation](#) by Michel Vanvaerenbergh

Customers who bought items in your Recent History also bought:



 [Secrets of the Viking Navigators](#) by Leif K. Karlsen

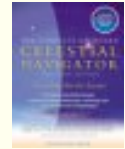

 [The Complete On-Board Celestial Navigator](#) by George C. Bennett

[Visit the Page You Made](#)

Turn your past books purchases into \$\$\$
[Learn more](#) about selling at Amazon.com today!

[Top of Page](#)

[Books Search](#) | [Browse Subjects](#) | [Bestsellers](#) | [Magazines](#) | [Corporate Accounts](#)
[e-Books & Docs](#) | [Bargain Books](#) | [Used Books](#)

[Amazon.com Home](#) | [Directory of All Stores](#)

Our International Sites: [Canada](#) | [United Kingdom](#) | [Germany](#) | [Japan](#) | [France](#)

[Contact Us](#) | [Help](#) | [Shopping Cart](#) | [Your Account](#) | [Sell Items](#) | [1-Click Settings](#)

[Investor Relations](#) | [Press Releases](#) | [Join Our Staff](#)

[Conditions of Use](#) | [Privacy Notice](#) © 1996-2004, Amazon.com, Inc. or its affiliates



amazon.com



VIEW CART | WISH LIST | YOUR ACCOUNT | HELP

WELCOME

YOUR STORE

BOOKS

APPAREL & ACCESSORIES

ELECTRONICS

TOYS & GAMES

MUSIC

CELL PHONES & SERVICE

SEE MORE STORES

Search

Browse Subjects

Bestsellers

Magazines

Corporate Accounts

e-books & docs

New & Used Textbooks

Used Books

Search:

Browse:

You clicked on this item...



Celestial Navigation for Yachtsmen

by [Mary Blewitt](#)

Average Customer Review: ★★★★★
Usually ships in 24 hours



Eligible for **FREE Super Saver Shipping** on orders over \$25. [See details.](#)

Price: \$10.36
You Save: \$2.59 (20%)

12 used & new from \$6.48

Practical Sailor

"For those interested in learning or brushing up on their celestial skills... not much on theory, just how to do it."

Or [buy used](#): \$6.48

You may also be interested in these items...

[Customers also shopped for](#)

Show items from:

- ▶ **All Products**
- [Books](#) (20)
- [DVD](#) (7)

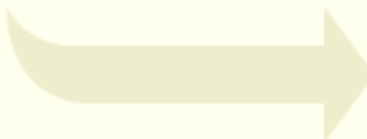

The Sextant Handbook

by Bruce Bauer
[More like this](#)



The Complete On-Board Celestial Navigator

by George C. Bennett
[More like this](#)



Celestial Navigation in a Nutshell

by Hewitt Schlereth
[More like this](#)



Boatowner's Mechanical & Electrical Manual

by Nigel Calder
[More like this](#)



Nigel Calder's Cruising Handbook

by Nigel Calder, Nigel Calder
[More like this](#)



Storm Tactics Handbook

by Lin Pardey, Larry Pardey
[More like this](#)



Emergency Navigation

by David Burch
[More like this](#)



How to Read a Nautical Chart

by Nigel Calder
[More like this](#)



World Cruising Routes

by Jimmy Cornell, Jimmy Cornell
[More like this](#)

[More results](#) ▶

New at Amazon.com

Visit our new [Seasonal Tableware Store](#) and save up to 40% on Lenox, Spode, and more.

\$25 Off Tools & Hardware

\$25 Offer

Take \$25 off when you spend \$199 or more on [Tools & Hardware](#) products offered by Amazon.com. [Here's how](#) (restrictions apply).

New at Amazon.com



REPLACEMENTS.LTD.

Find more than 600,000 china, crystal, and silver products in the [Replacements, Ltd. Store](#).

Where's My Stuff?

- Track your [recent orders](#).
- View or change your orders in [Your Account](#).

Shipping & Returns

- See our [shipping rates & policies](#).
- [Return](#) an item (here's our [Returns Policy](#)).

Need Help?

- Forgot your password? [Click here](#).
- [Redeem](#) or [buy](#) a gift certificate.
- [Visit our Help department](#).

Search

for

Your Recent History

[Learn More](#)

Recently Viewed Products

- [Practical Celestial Navigation](#) by Susan Peterson Howell
- [Celestial Navigation Simplified](#) VHS ~ William F. Buckley Jr.
- [Latitude Hooks and Azimuth Rings](#) by Dennis Fisher
- [The Stars](#) by H. A. Rey
- [The Discarded Image](#) by C. S. Lewis

Customers who bought items in your Recent History also bought:

- [Find the Constellations](#) by H. A. Rey
- [Studies in Medieval and Renaissance Literature \(Canto\)](#) by C. S. Lewis

▶ [Visit the Page You Made](#)

Turn your past books purchases into \$\$\$
[Learn more](#) about selling at Amazon.com today!

[Top of Page](#)

[Books Search](#) | [Browse Subjects](#) | [Bestsellers](#) | [Magazines](#) | [Corporate Accounts](#)
[e-Books & Docs](#) | [Bargain Books](#) | [Used Books](#)

[Amazon.com Home](#) | [Directory of All Stores](#)

Our International Sites: [Canada](#) | [United Kingdom](#) | [Germany](#) | [Japan](#) | [France](#)

[Contact Us](#) | [Help](#) | [Shopping Cart](#) | [Your Account](#) | [Sell Items](#) | [1-Click Settings](#)

[Investor Relations](#) | [Press Releases](#) | [Join Our Staff](#)

[Conditions of Use](#) | [Privacy Notice](#) © 1996-2004, Amazon.com, Inc. or its affiliates



- [Home](#)
- [View Cart](#)
- [Contact](#)

POWER UP YOUR PDA!
25% Off Orders of 2 or More Items Totalling \$25 or More!

My PalmGear | Developers



- [Software](#)
 - [Top 50](#)
 - [eBooks](#)
 - [Devices](#)
 - [Accessories](#)
 - [Knowledge Base](#)
 - [Community](#)
 - [StreamLync2](#)
- New & Updated Specials Essentials Gear's Choice Categories SL² Enhanced Education & Enterprise

Search Software Titles

[Advanced Search](#) [Search](#)
[Tips](#)

Software

The selected product has is no longer available.
Please use the search function to locate an alternative.



Your cart is empty

Your recent downloads

[what is this?](#)

New to handhelds?

[PDA Power Training](#)

[Enhance your PalmGear experience](#)

[Find the answers you need](#)



PocketLingo

Featuring

- First-Rate Content
- MyWord List
- Study Cards
- Multi-Dictionary
- Tap-and-go & more

Best Sellers

- ▶ **[Handmark Checklist 2.0](#)**
#1 Checklist Manager for the Palm OS!
- ▶ **[Top 1000 Hi Res 3D Icon Collection 1.2a](#)**
3D Hi Res Iconset for SplashID 3*, Agendus, DateBk5.1, MonthPlanner, Datashield & Handyshopper users.
- ▶ **[EarthDefender 1.05](#)**
Defend the earth from invading aliens!
- ▶ **[AppLock 1.02](#)**
Take your data security to a new level!
- ▶ **[PilotMicroRace 1.32d](#)**
Fun 1 or 2 player(s) car racing game!



Never miss our specials!

Receive notification of all PalmGear.com specials and feature applications directly in your inbox.

▶ **PalmaryClock Screensaver**

1.0

PalmaryClock Screensaver is a full-featured clock with skin and background support. Slideshow mode, Users skins and backgrounds, Fast Skin and Background processing.

▶ **Tip-Tap for Palm OS 1.1**

Board game in the spirit of Color Lines

▶ **Robot Panic (Puzzle Games)**

2.0H

An old time classic puzzle game as never seen before. Hi-Res+ fully supported.

▶ **emWord Elevator 1.0**

Excellent word game for your PDA. First time on your Palm device. Just RECONSTITUTE WORDS from SCRAMBLED LETTERS. ELEVATE THE WORDS using UP and DOWN elevator buttons.

▶ **ZLauncher 4.30**

The Most Customizable & Feature-packed Application Launcher! An Ultimate System Manager for PalmOS!

International



[Simplified Chinese](#)
简体

[Traditional Chinese](#)
繁體



[Company Info](#) | [Advertising](#) | [Terms of Use](#) | [Privacy Policy](#) | [Refund Policy](#) | [Contact Us](#)

© Copyright 1997-2004 - All Rights Reserved

PalmGear.com uses the PalmGear trademark under exclusive license from PalmSource, Inc.

Navigator 4.1 user manual

Table of contents

Version 4.1 [new features](#)

The [access](#) window

>> Chapter 1 - [Celestial Navigation](#)

- [Preparing](#) the sky
- The [twilights](#)
- Taking [altitudes](#)
- The [meridian passage](#) for the Sun (noon sight)
- [Better meridian](#) passage
- Using [artificial horizons](#)
- Print your own [Nautical Almanac pages](#)

>> Chapter 2 - [Star Finder](#)

>> Chapter 3 - [Chart Navigation](#)

- [Vector and raster](#) charts
- Using [raster images](#)
- [Printing](#) chart images
- Chart [tools](#)
- Navigator [desktop](#) files
- Using the [GPS interface](#)
- [Troubleshooting](#) the GPS connection
- The [Leg calculator](#)

>> Chapter 4 - [ChartMaker](#)

- [How it works](#)
- [Mercator latitude scale correction](#)
- [Which images](#) can be used ?
- Tips for [scanning](#) charts
- Choosing the 3 [reference points](#)
- Importing a [raster chart image](#)
- Making [vector charts](#)

Celestial Navigation links

1. New to celestial navigation? To understand how it works, go to the [Fundamentals](#) page.
2. Other Navigator [screen shot](#)
3. Navigator software [Homepage](#)

Version 4 new features

[▲ to table of contents](#)

Version 4 of the Navigator software has many new features and improvements.

In the celestial navigation side, I implemented several features suggested by users and Brazilian Navy School officers. I'm proud to announce that the program was adopted by this school, for use in celestial navigation classes.

These are the new features:

Star Finder

The star finder was improved, particularly the printed results.

- > Now the star chart and table are printed in a single sheet of paper.
- > Boat course indication, for easy orientation.
- > Improved celestial object identification in the chart . Now all planets have their own icons, for easy identification. The most visible stars (mag<3.0) are also indicated by a larger star icon.

Celestial Navigation

- > Checkbox do select/deselect LOPs, for Astronomical Position calculation. Now you don't have to delete a LOP that is either wrong or nearly parallel with other LOP. Just deselect it and recalculate the position.
- > Automatic LOP transport. In the prior versions, to calculate a running fix, it was necessary to transport each LOP by hand. In version 4.0, you can specify the boat course and speed; and the LOPs will be automatically transported (either to current time, LOPs mean time or last LOP time) when calculating the astronomical position. This feature makes calculating running fixes as easy as normal twilight positions.
- > Better Moon position calculations (version 4.+).

Chart Navigation

Perhaps the most dramatic usability improvement is in the chart navigation area. For a long time I have been looking for a way to import electronic charts into the program's chart viewer. I have considered many "popular" electronic chart formats, but was always confronted with same problems:

- Proprietary formats - Most electronic chart formats in use today are proprietary, and there is little or no documentation on how parse these chart files. Many chart vendors sell charts and viewer software, and are not interested in releasing chart format documentation.
- Low availability and high price - Electronic charts are sometimes more expensive than printed versions and not available for all areas in the world, as printed charts are.

For the reasons above, I choose to implement plain raster chart import directly from popular image formats (.bmp, .gif and .jpg). This has the following advantages:

- Scanners today are very cheap. One can buy a good A4 page scanner for less than US\$100.
- Gif and jpg are very popular image formats in the Internet. There are many charts available in these formats on the Internet.
- Most users already have paper charts on the areas of interest. That is, they have already paid for the license to use these charts.
- Some satellite images can also be used .
- Allows the flexible 'do it yourself' approach.

Also:

- > Fixed strange chart scrollbar behavior.
- > Changed the help format from Windows help to html.

The access window

[▲ back to the top](#)

Both **Navigator** and **ChartMaker** programs have access windows. These are the main menus of these applications. From the access window you choose the module you want to work with.

For **Navigator** you have the following options (buttons):

- Chart Navigation
- Celestial Navigation
- Star Finder

For **ChartMaker**:

- Make vector chart
- Import chart image

Take some time to read the License Agreement and disclaimer (click "important information"). Closing the access window will terminate the program.

Chapter 1 - Celestial Navigation

[▲ to table of contents](#)

The goal of the celestial navigation is to find the **astronomical position**, the position of the boat. In this section we will see how this can be done with the help of Navigator software. As we have seen in the **fundamentals**, crossings of two or more Lines of Position, taken for two or more celestial objects, define this position.

Preparing the sky

[▲ back to the top](#)

But before you start taking altitudes of celestial objects, you must be able to find them with the sextant. Trying to find a star with the sextant on a rocking boat is not easy. The eyepiece has a relatively small angle of view and the sight is twisted by the sextant mirrors.

One technique to find a star is to turn the sextant upside down, point it to the star, and bring the horizon by adjusting the arm.

Better yet is to know the approximate altitudes and azimuths of the stars you are going to observe. This is known as **preparing the sky**.

The twilights

[▲ back to the top](#)

Navigators wake up early. They do so to take advantage of the two times of the day when the sky is in best condition for celestial navigation: the **twilights**. In the civil twilights - times when the sun is 6° below the horizon - it's dark enough to see the stars and planets, and light enough to see the horizon. This happens before sunrise and after sunset.

The first step of the sky preparation is to determine the time of the twilights.

To calculate the times of twilights do:

- Select the **Sun** in the celestial objects listbox.
- Set the date of the observation. Since you are probably going to prepare the sun in the night before, set the date to the following day.
- Set the assumed position (Latitude and Longitude). It's the position you think you are going to be in the time of the observations.
- Select the tab "Other calculations"
- Press "Object data" button.

The last two lines show the time of twilights. Like this:

```
dawn civil twilight: 9:13 GMT
Set civil twilight: 20:46 GMT
```

Selecting stars and planets

[▲ back to the top](#)

Now that we know the twilight times, you can select the celestial objects you are going to observe. At any time, **Navigator** gives you more than 33 celestial objects to choose from. Of course you will only need 4 or 5. To select stars and planets you will observe, follow these guidelines:

- Select stars and planets that you are most familiar with.
- Select the brighter objects. Planets are easier to spot, because they are very bright. Some stars are also very bright and easy to find. Some constellations have distinct look and are easier to locate.
- Select objects with altitudes between 30° and 60°. Less than that you result in greater atmospheric refraction error, which is not easy to correct (because it depends changing on atmospheric conditions). And altitudes higher than 60° are more difficult to measure.
- Do not select stars that have similar azimuths or that are in opposition. The resultant Lines of Position will be nearly parallel, which is undesirable.

To **prepare the sky** do:

- Set date and twilight time of your next observation.
- Set the assumed position (Latitude and Longitude).
- Select the tab "Visible stars".
- Press the "Calculate" button.

Now choose the stars in the spreadsheet or chart. To see the name of star in the chart, click the mouse over it. The name will show in a "hint label". Or select the star in the spreadsheet. A circle will show around the correspondent star in the chart.

If a printer is available, Navigator can print a convenient sky preparation (one page), with visible objects table and polar chart.

Input tip: When unsure about how to enter a value (date/time format, number format or number unit), place the mouse cursor over the input box. A hint will show with the field name, input format and/or example.



Taking altitudes

[▲ back to the top](#)

Now lets take the actual measurements. Take the following items to the deck of the boat:

- 1) Sextant.
- 2) Watch.
- 3) Pencil.
- 4) Paper with your sky preparation. Attach the paper to a board, so it's easy to take notes and your work will not be carried away by the wind.

Try to establish a routine to handle these items. You will be observing two numbers (altitude and time) at once, possibly on a rocking boat, so don't let these items make things difficult in the critical time. You might want to use preprinted tables to organize your data, like the one below. Save them as the documentation of your work.

Date:		twilight time:		assumed lat:		assumed lon:		
index error:		watch error:		time zone:		Obs:		
celestial object		sky preparation		observations		results		
LOP	Name	Altitude	Az	Time	Hi	Delta	Dir	Az
1								
2								
3								
4								
5								
6								
Astronomical position for ____ LOPs				Lat:		Lon:		

-> Click [here](#) to open this table in a new window, to print some copies

When taking an observation, set your sextant to the expected altitude and point it to the expected azimuth (from your "preparation"), using a hand compass. The celestial body will probably show in your view.

- Adjust the sextant to the correct instrumental altitude. Write name, time and altitude of the observed celestial object.
 1. It's good practice to adjust the sextant micrometer drum always in the same direction. For example, put the star below the horizon and then bring it up by turning the drum in the same direction in all observations. If you go past, repeat the operation from the start. Do the same for the Index Error measurement. The sextant will give different readings, depending on the direction you adjust the drum. Using the same direction for both altitudes and index error measurements cancels this problem.
 2. After adjusting the sextant's drum, read the watch first, because it's changing fast. Write the time. Then write the sextant altitude.

Before **and** after taking altitudes, measure the Index Error:

- Set the altitude to 0°00' and point to the horizon.
- Adjust the drum until both sides of the horizon are level.
- Read the Index Error and write it.

Back to the navigation table, run Navigator.

- Enter the index error.
- Enter Height of the eye (Dip). In version 3.0+, you can choose the Dip units (meters, feet or minutes) .
- Enter **watch error**, in seconds. See [keeping the time](#) for more information on time keeping methods.

Note on the index error: In versions prior to 2.5, the IE was typed with the plus signal when the index error was inside the drum scale. This number was then subtracted from sextant reading by the program.

Many users complained that this input convention was against the common practice in celestial navigation. They were used to work with the Index Correction (**IC**), with signal - when the IE was inside the arc scale.

After many messages, I agreed. Starting with version 2.5 and up, I changed this. So, if you are upgrading, make sure you use the correct input convention, as illustrated on the right.

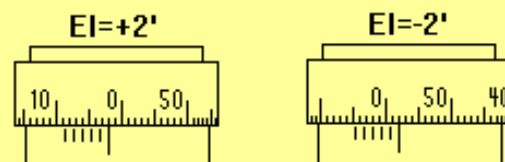

Navigator 2.5 and up

Type IC = -2

type IC = +2

Old versions (navigator 2.0 and prior)

Type +2

type -2

Clear all previous LOPs:

- Select the tab "Astronomical Position".
- Press the toilet button, to clear all LOPs.
- Now select the "Line of Position" tab.
- Set the assumed position (Latitude and Longitude).

Now enter the measurements, one by one. For each celestial object, do:

- Select the celestial object from the listbox.
- Enter time of the observation.
 1. You can use local time or GMT time edit boxes. In this case, automatic conversion to GMT is done.
 2. If using local time, make sure the time zone and watch error edit boxes are correctly set.
- Enter altitude of the celestial body.
- Press the "Calculate" button.

The result will be something like this:

```

LOP for Sun
05/04/2001 13:43:54 GMT
Ass.Pos. Lat:23°40.0'S Lon:40°30.0'W
Inst. Altitude: 56°24.5'
Altitude of lower limb
Altitude corrections -----
Par: 0.0' Refr:-0.6' SD:16.0'
Dip:-3.1' IE:-2.0'
Total Altitude Correction:10.3'
Corrected Inst Altitude: 56°34.8'
Object Positional data -----
LHA: 344°48.9'
GHA: 25°18.9'
Decl: 6°13.8'N
LOP Results-----
Calculated Altitude: 56°37.8'
Intercept: -3.0 NM (away)
Az.calc: 28°
  
```

The two last lines have the results (Delta and Azimuth).

If you feel the result is consistent with the expected , press the button "Save LOP". This will save this Line of Position for the calculation of the Astronomical Position (Fix), which will be done after you calculate all LOPs.

After calculating and saving all LOPs, go for the astronomical position calculation:

- Select the tab "Astronomical Position". The LOPs you have just saved will be in the spreadsheet.
- Press the "Calculate" button, to calculate the astronomical position. Your astronomical position will show. Please note that, in order to calculate the astronomical position, you have to have two or more LOPs. Having more lines is advisable, because errors in one observation will show more easily. A good number is 4 LOPs. Also, as we will see, sometimes we are going to discard some of them.

Refining your calculations

[▲ back to the top](#)

To achieve good results in celestial navigation, you need to be methodic. As you can see, there are many steps, and a mistake in one of them will only show in the end, if at all.

Enumerate the tasks you are doing - or are going to do - and read the measurements loud before taking note (navigators are said to speak to themselves). Make your notes in an organized table, one row for each celestial object. In the header of the table, write date, assumed position, time of twilight and index error. Have the sky preparation ready before going to the deck.

But even with all the care, some errors will eventually show. Wrong time or altitude (the so called 60 mile error). Bad star identification. Even wrong date. The important thing is to detect mistakes, and drop the LOPs with problem.

Having good dead reckoning navigation helps a lot. It's also a good idea to take a look in the chart showing the Lines of Position. If one of them seems out of the flock, you may deselect it and recalculate de position. This is why it's good to have more lines.

Another problem is to have two or more LOPs that are nearly parallel. They will probably cross very far from the correct position, even if they are close together. Navigator accounts for this situation by giving a small weight to crossings forming small angles. But it's better to deselect one of them and recalculate the position.

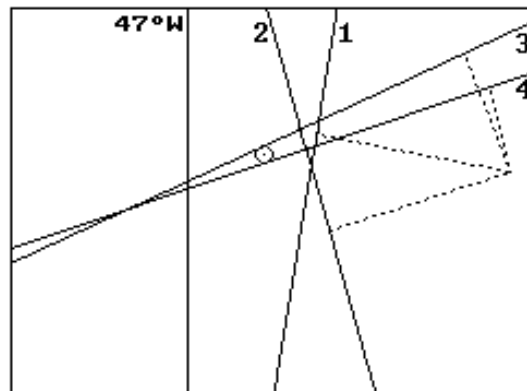

LOPs 3 and 4 nearly parallel. Select only one of them.

In the figure above, we can see that LOP 3 and 4 are nearly parallel. Deselecting one of them would improve the resulting calculated astronomical position.

Observing the Sun

During the day, you can observe the Sun and the Moon. If you can see both at the same time, and they are in suitable positions for observation, you can calculate a fix, using the two lines of position. The procedure is the same described above for stars and planets.

The only difference is that the Sun and Moon have appreciable diameters (about 32'). When measuring the altitude of Sun and Moon, align the lowest part of the body with the horizon. This is known as the lower limb. Navigator will correct for the semi-diameter automatically.

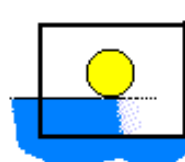

Sextant image

You can also use the upper limb. In this case, uncheck the "Use lower limb" checkbox.

Running fix

[▲ back to the top](#)

The altitude of the same celestial object in two different times may be used to find the position. For example, you can take two Lines of Position for the Sun, one in the morning and one in the afternoon. Because your boat is moving, you will have to transport the first line to the second line time. The position obtained with this method is called **running fix**.

Navigator (version 4.0 and up) can be set to transport LOPs automatically, when calculating the astronomical position. This is done by moving the assumed position. The LOPs chart shows the original LOP (blue) and the transported (red).

Take a look at the Auto Transport frame in the image to the left. This is where LOP transport is setup.

The screenshot shows the 'Celestial Navigation' software interface. The 'Auto Transport' frame is visible, with the following settings:

- Auto Transport: Don't transport, To latest LOP Time, To LOPs Mean Time, To Selected Time
- 26/07/2000 18:25:14 GMT
- Course: 60° T
- Speed: 2.0 Knts
-

The 'Line of Position' table is as follows:

#	Object	Date/time	Hi	Delta	Az
<input checked="" type="checkbox"/>	Sun	26/07/2000 12:43:37	33°30.5'	-25.6	43°
<input checked="" type="checkbox"/>	Sun	26/07/2000 18:25:14	26°30.5'	8.5	308°

The 'Astronomical Position' table shows the calculated position:

AP for LOPs 1,2
1 crossings calculated
26/07/2000 18:25:14 GMT
Lat: 23°31.4'S
Lon: 46°46.7'W

The 'Auto Transport' frame also displays the 'Assumed position' (Lat: 23°25.7'S, Lon: 046°30.0'W) and the 'Sextant' (instrumental altitude: 26°30.5', IE: -2.1', Dip: 2 meters).

- Choose one of the following transport modes.
 - Don't transport
 - To latest LOP time
 - To LOPs mean time
 - To Selected Time (i.e. specified in the top time frame)
- Click 'Edit boat C&S' (course and speed) and update boat movement data.
- Click 'Calculate' to calculate the astronomical position.

Simple meridian passage (noon sight)

[▲ back to the top](#)

When the Sun crosses our meridian, its azimuth is either 0° or 180° (North or South). This means that a Line of Position (LOP) for the Sun, taken at this time, will have constant latitude. This event is called transit or meridian passage. For the Sun, it happens around local noon (+/- 20 minutes).

The navigator can take advantage of this event to check the latitude. The longitude can also be calculated, although with smaller precision.

This is what you must do:

- Start taking observations of the Sun (time and altitude) about 25 minutes before the expected transit time. In **Navigator**, select the Sun and use the command **Object Data** to estimate the transit time for the Sun in your assumed position. Take a couple altitude observations (p.e. 5 minutes apart) until 15 minutes before transit.
- At transit time, observe the highest altitude the Sun reaches. This is known as culmination altitude. It's easy to measure, since the Sun will appear to hang with constant altitude while passing your meridian. After that, it will start to go down.



- Write the culmination (maximum) altitude.
- Keep checking the altitude until the Sun, now going down, is at the same altitude it was in one of the observations made before transit. The time of transit is the average of two times with equal altitudes (before and after transit).

For example, if you measured $61^{\circ}32'$ at 11:45:30 and $61^{\circ}32'$ at 12:10:10, the time of transit is $(11:45:30+12:10:10)/2$ or 11:57:50. The altitude value is the maximum altitude you observed (near transit time).

- Enter the transit time (the average you calculated) and the culmination altitude in **Navigator**. Select the tab "**Other calculations**" and click the "**Simple Sun Meridian Passage**" button. Program will give your position.

It's important to understand that the Latitude result is related to the maximum altitude the Sun reaches, and the Longitude to the exact time of the passage. So, the latitude can be safely determined even if you don't have a reliable watch.

Better meridian passage calculation

[▲ back to the top](#)

While the method just described is OK, it does not account for two factors: Sun declination change and boat position change. These two factors can affect the longitude result.

The Sun declination is always changing. It changes faster on equinoxes (spring and fall) and slower in solstices (summer and winter). So, the Sun 30 minutes after the passage is not in the same place (in the celestial sphere) as 30 minutes before the passage.

The boat movement during this period can also be of significance, particularly if the boat is fast and is moving along the meridian.

These two changes affect the actual meridian passage time. In this case, the average time between two equal altitude observations (before and after transit) is not the meridian passage time, but rather the culmination time. A correction must be applied to find the right passage time (and the Longitude).

To perform this calculation on the Navigator, select the tab "**Other calculations**" and click the "Sun Meridian Passage by Equal Altitudes" button. The form below will show.

Enter maximum altitude (w/o corrections), IE, Dip, GMT date, GMT time of altitude 1 (before transit, w/o watch correction), GMT time of altitude 2 (after transit), watch error, boat speed, boat course and assumed position. The GMT times 1 and 2 are the ones of equal altitude observations (the actual value of the altitude is not used in the calculation, but remember to write it down, because you will have to use the sextant to measure the maximum altitude between the two observations).

The correction i is the difference, in seconds, between the culmination time and the transit time. It can be as much as a minute, or 15' in the longitude.

Please note that there are a couple **conditions** to use this method:

1. Sun altitude must be at least 65°.
2. The Sun's azimuth must be at least +/-20° on equal altitude observations.
3. The equal altitude observations must be up to 40 minutes - before and after - transit time.

This method is particularly useful near the Equator.

Tip: If there are clouds in the sky, it's recommended that you take several observations before transit. If you take only one, the Sun may become covered in the critical time after transit. By having many observations, you increase the chance of having one usable observation pair.

Artificial Horizon

If you live in a city far from the sea, you can't take altitudes of celestial bodies with a marine sextant, because you can't see the sea horizon. One way to work around this problem is to use an **artificial horizon**. The artificial horizon can easily be made with a plate filled with liquid. Water will do, but oil is better. The surface of a pool can also be used, if there is no wind or waves (the water surface must be completely flat).

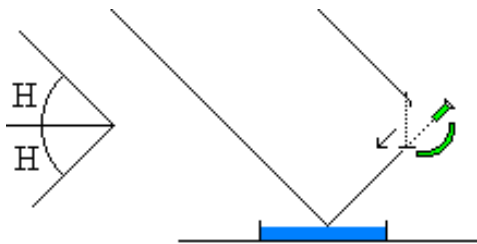

To take the altitude with the artificial horizon, point the sextant towards the artificial horizon and make reflected image of the celestial body coincide with the direct image. The angle you read is twice the altitude of the body, as illustrated in the figure below.

Also read the index error.

Navigator automatically corrects for the use of artificial horizons:

- The program divides instrumental altitude by two. Enter sextant reading directly.
- The Dip and semi-diameter corrections are set to zero.
- The index error is also divided by two.

Printing Nautical Almanac Pages

Navigator (registered version 2.5 or latter) has a Nautical Almanac page generator/printer. These pages are not exactly the same as real almanac pages, but they contain most of the information needed to do celestial calculations in the traditional way, without the computer.

Navigator generates the so-called "daily pages" (the ones with 3-day celestial data for planets, stars, Sun, Aries and Moon). The yellow ("increments") pages are not generated because they don't change from year to year. You can use the yellow pages of an old almanac or do the interpolations with a pocket calculator.

I choose to make the Navigator daily pages as similar as possible to actual almanac pages. But there are differences:

- Did not include the latitude dependent tables (Twilights, Sunrise, Moonrise, Sunset, Moonset).
- Did not include the Aries meridian passage time. This number is used to calculate the meridian passage of stars, and is seldom used.
- Did not include the Sun's Equation of Time and meridian passage table. You may use an old almanac for the Sun's meridian passage calculations, as these tables are almost unchanged from year to year. Just use the table of the same day.
- Did not include the Moon's meridian passage and age table.
- Did not include the planets' SHA and meridian passage table.
- Added three stars not included in most Nautical Almanacs

I plan to include some of these numbers in future versions. Feedback from users about what features are most important is welcome.

If you compare the Navigator's almanac pages with nautical almanac pages, you will note small differences in the

numbers. These are caused by different celestial calculation methods and should not be bigger than 0.5'. This error is small when compared with other imprecisions that affect celestial navigation, and will not impact your position significantly.

Printing the almanac pages

To print almanac daily pages, do:

1. Go to the celestial navigation window.
2. Select the "Other calculations" tab.
3. Press the "almanac pages" button. The "Almanac Pages" window will show.
4. Set the initial date for the 3-day page.
5. Select "Aries and planets" (left side page).
6. Press "Build page" and "Print".
7. Select "Sun, Moon and Stars" (right side page).
8. Press "Build page" and "Print".
9. Click in the "Arrow" button to advance 3 days and repeat operations from step 5). Proceed until you have printed all the pages for the desired period.

In order to print your almanac pages, you have to use a non-proportional font (a font with fixed pitch). The default font is Courier New, size 7. Pages printed with this font will use a single sheet of paper (size A4). I know this is a small font, but using a larger one will result in two paper sheets for each page. You may experiment with other non-proportional fonts. True type fonts are better, because they can be resized to any small size.

Check the online web service, open to the public. Click to [visit this service](#).

Chapter 2 - Star Finder

 [to table of contents](#)

Navigator Star Finder (version 3.0+) was completely redesigned. To accommodate the new set of features, this chart of the visible sky was moved to its own window (in previous versions, it was part of the celestial navigation window).

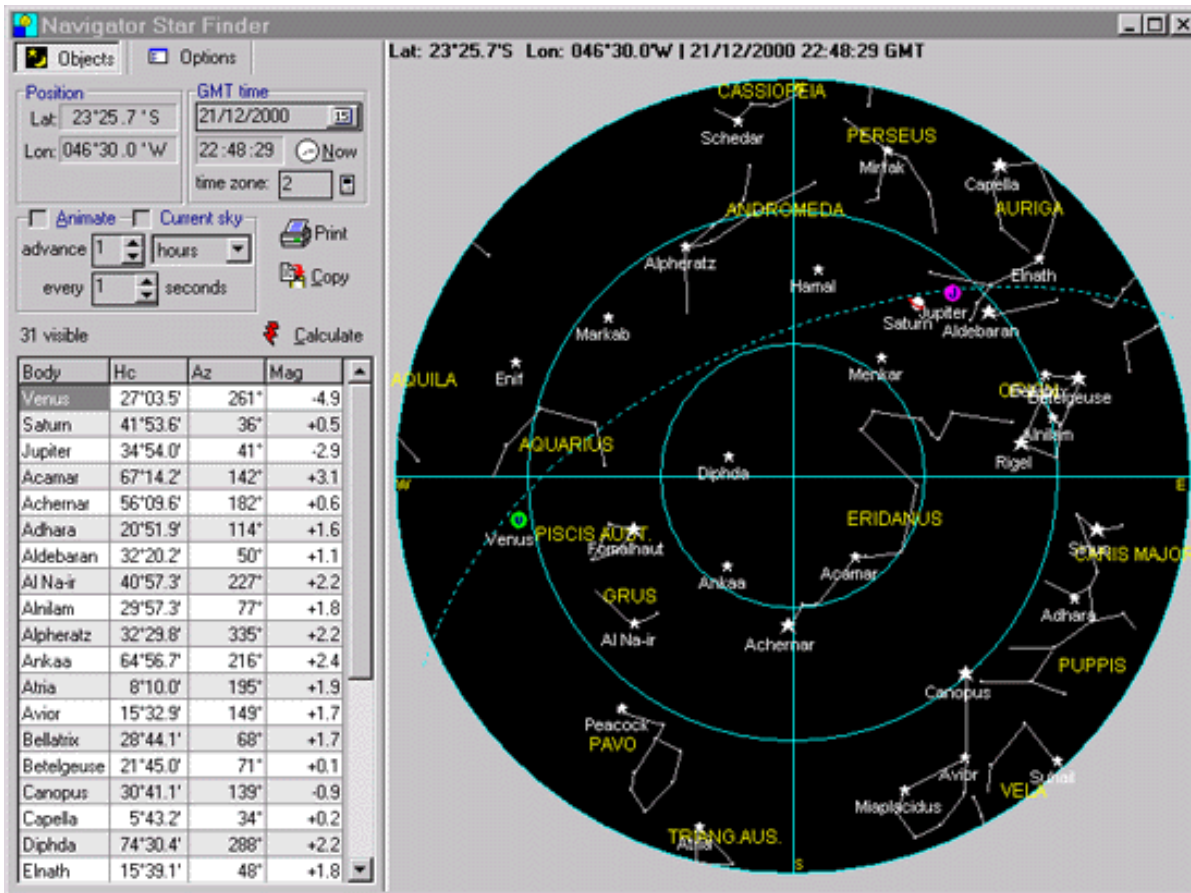

The new features include:

- Constellation lines and names make it easy to identify constellations and celestial objects.
- Ecliptic plot shows the path of the Sun, Moon and planets.
- Celestial objects grid can be sorted by columns (ascending and descending order) clicking the column header.
- The spreadsheet now includes object magnitudes (note: many celestial objects have changing magnitudes. These values are fixed, to be used only as rough estimate).
- Mouse cursor shows altitude and declination when moving. When pointing an object, its name, altitude, azimuth, declination and right ascension are shown. Values cursor is transparent, so you don't lose the big picture.
- Prints the object list and chart. The printed chart uses the printer higher resolution.
- Time zone is now imported from the operating system, accounting for Day Light Savings time.
- Sky background color indicates the light conditions (day=blue, night=black and twilight=navy).
- Windows® Clipboard support allows to cut-and-paste the chart to other applications.



- Overhead view option, so you can look up to the sky and the chart simultaneously. In this representation, E and W are flipped and the chart is to be viewed upside down (see figure to the left)

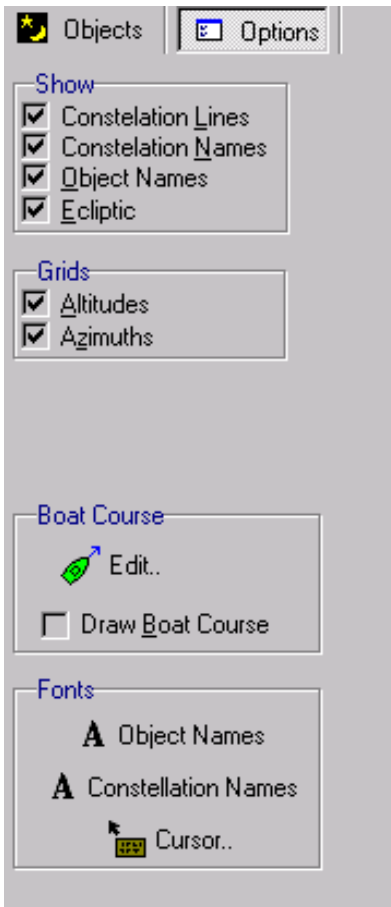

- Options tab allows easy and interactive chart setup (see figure to the left).
- Boat course plot, to easy printed chart orientation.
- Star finder chart and table now print in the same sheet of paper, much more convenient.

Using the Star Finder is easy:

1. Set your position (Lat/Lon)
2. Set the GMT date and time. If you opened the star finder by clicking the button in the celestial navigation window, these values are automatically set.
3. Set the boat course (optional)
4. Click the **Calculate** button

You can also animate the sky, specifying time increments and calculation frequency. This can produce very interesting animations, like how the sky changes from hour to hour, day to day and year to year.

And it can also be set to show the current sky.

Chapter 3 - Chart Navigation

[▲ to table of contents](#)

The **Navigator** chart module is relatively new (started in version 2.5), but has received important additions in version 4.0. It's now much more useful with the addition of raster chart capabilities.

Instead of supporting the existing electronic chart formats, I choose to provide a set of tools to allow the user to

import existing paper chart images into the program. This 'do-it yourself' approach gives the user maximum flexibility.

All **Navigator** files are in text format and their structures are easy to understand, to allow integration with other applications and Internet file sharing. The table below enumerates the **Navigator** data file types.

File extension	Description
.CHT	Navigator vector chart file
.NAV	Navigator desktop file
.CID	Navigator chart image description (raster image)

Vector and raster charts

[▲ back to the top](#)

The **Navigator** chart engine can show two kinds of charts: vector charts and raster charts.

Vector charts - In this type of chart, islands, continents, routes and tracks are represented by polygons and lines, defined by a collection of points (Lat/Lon pairs). This kind of chart can be easily zoomed in and out, and is very fast to render. Navigator uses its own vector chart file format. No other chart file format is supported at this time. These files can be produced, from scanned charts, using the **ChartMaker** program.

Raster charts - These charts are images (normally scans of paper charts). Navigator can use raster images in formats **JPG**, **GIF** or **BMP**. These are popular file formats in the Internet, and many charts can be found for download over the Net.

All raster chart image files must first be imported - using **ChartMaker** program - before they can be used in the **Navigator**. This step is necessary to describe the chart image scale (i.e. how pixels in the image map to the real world).

Both vector and raster charts can be produced or imported using the **ChartMaker** program, which is described in the next chapter.

Using raster chart images

[▲ back to the top](#)

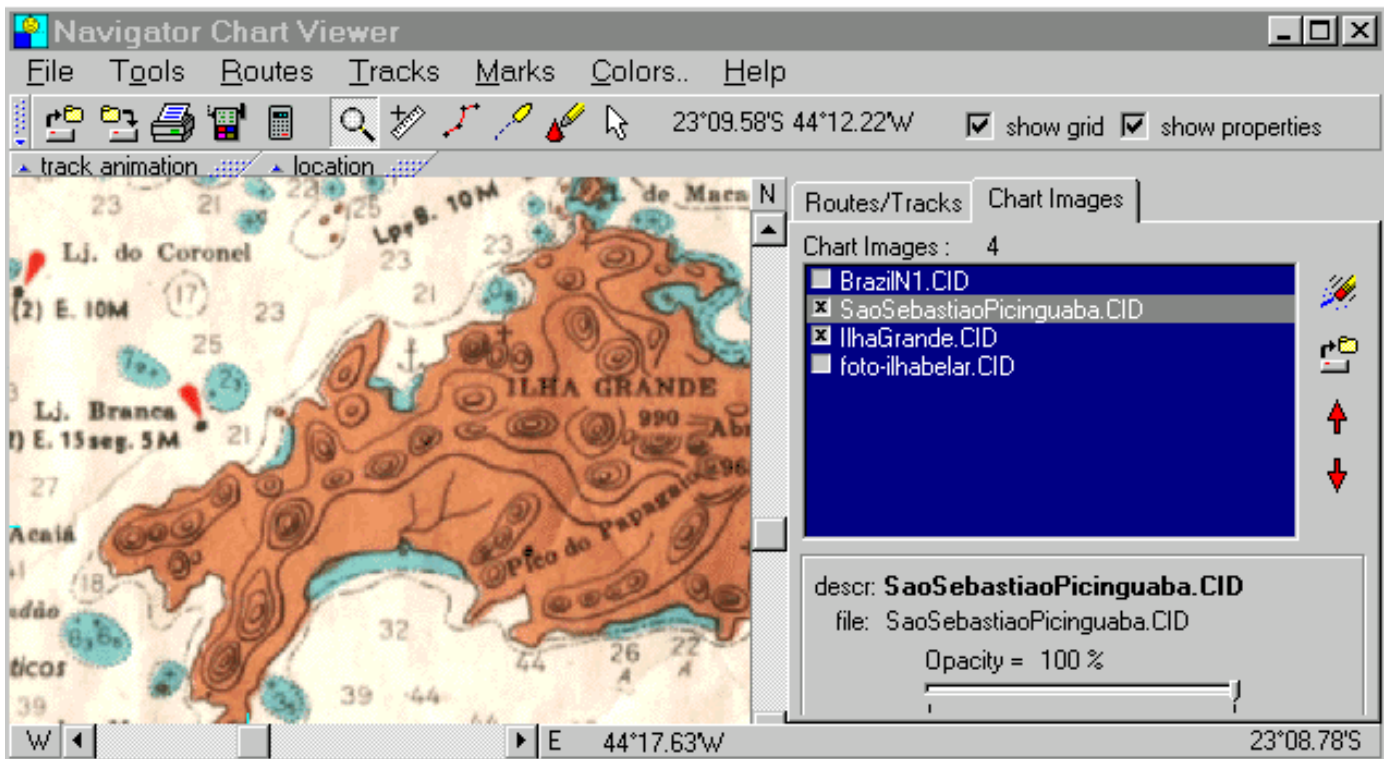

In the image above you can see two raster chart images visible in a desktop, on a zoom animation. Before opening it in the **Navigator**, a raster chart image it must be imported. This is done only once for each image, with the **ChartMaker** program. The step creates a .CID file that is associated with the chart image (GIF or JPG). This file contains:

- Name of the associated image file (GIF, JPG or BMP)
- File description
- Reference points (which define how the image pixels map to the real world)
- Image MD5 digital signature (to prevent accidental changes in the chart image)
- Chart limits (outside rectangle)

Once the CID file is created, it can be added to a desktop. Click the chart image open button and select the CID file. Many chart images can be added to a given desktop. Images can be either visible or not. To play with chart visibility, use the small checkbox in the chart images listbox.

Tip: Since images are large in size, making many visible at the same time would consume a lot of memory. Making only the charts you need **visible** reduces the amount of memory used by the program. A memory of at least 32MB is recommended to use raster charts.

The image resampling process also consumes a lot of CPU power. To reduce the bumpy behavior while zooming or scrolling, these calculations are implemented in different threads of program execution. That's why it takes some time for the raster charts to show after you zoom or scroll.

You can also play with raster image **opacities**, making them partially transparent. This allows you to see how two charts overlap each other or compare them with the vector chart underneath.

Tip: Partially opaque (i.e. transparent) chart images consume CPU power - a 100% opaque chart will display a lot faster.

The chart images rendering order can also be changed, using the up and down arrow buttons in the right. The rendering order is:

- 1- Background (sea color)
- 2- Vector chart polygons
- 3- Chart images (top-down order in the listbox)
- 4- Routes, tracks and marks

Tip: To transfer a CID file to another computer (or to share it over the Internet) , you also need to transfer the associated image file (GIF or JPG). Since the CID file contains the image file digital signature, there is no risk of accidentally changing the image while copying.

Printing Chart Images

[▲ back to the top](#)

Navigator Desktops containing raster chart images can be printed. You can use this to integrate different charts together in a single and compact printout. Quality is even better than the computer screen, because printers have a much higher pixel resolution than monitors (monitors typically 75 DPI x printers 300 or 600 DPI).

This quality comes at a **cost**. Resampled chart images may turn out big, requiring a lot of CPU cycles and memory to calculate. So be patient and make sure your computer has at least 64MB of memory. If you have a laser printer, limit the print resolution to 600 DPI. Don't use 1200 DPI, because this would result in really big resampled image and would probably hang your computer.

I'm working to make sure that the printing process is smooth. You may find problems in extreme situations (printing large chart images with high resolution printers and little memory available).

Partially opaque (transparent) images are not supported by printers. When printing, all chart images will be rendered opaque.

Chart tools

[▲ back to the top](#)

The **Navigator** chart viewer has the following tools:

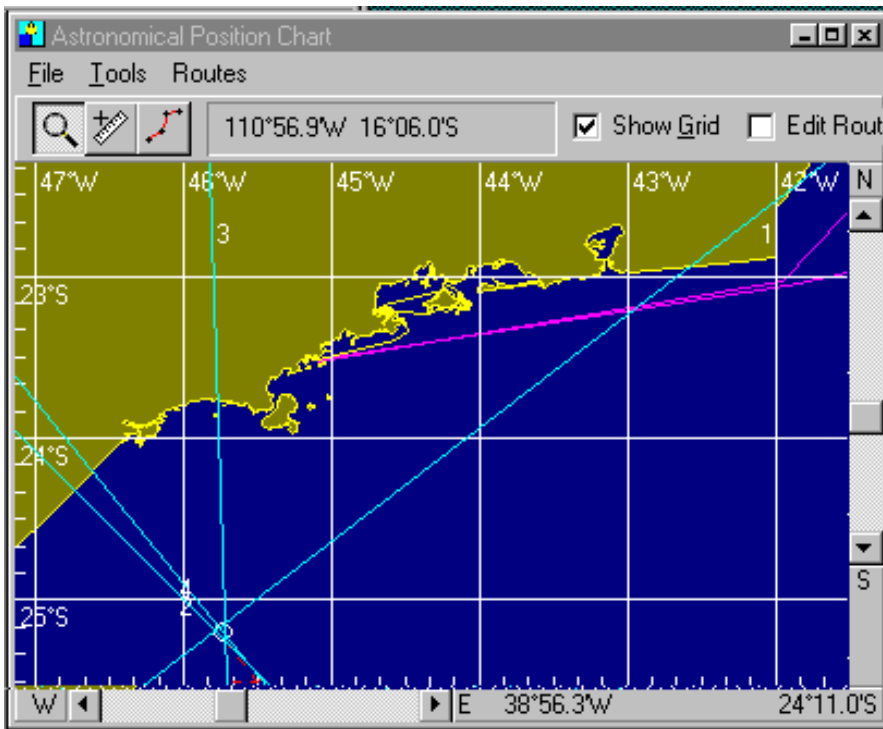

Zoom tool

Zoom - Lets you zoom in and out the chart, from the whole world to a very small scale. To zoom in, press the left mouse button in the point you want to focus (screen center). To zoom out, use the right mouse button or click the left mouse button with Shift key pressed.

Measure - Click a position and drag the mouse. The caption will show two numbers: COG and Range.

COG is Course Over Ground. It's the true direction of the line. Range is the distance between the end points, in nautical miles.

Both COG and Range are calculated using Lines of Great Circle (LGC). This means that they are accurate, even for large distances.

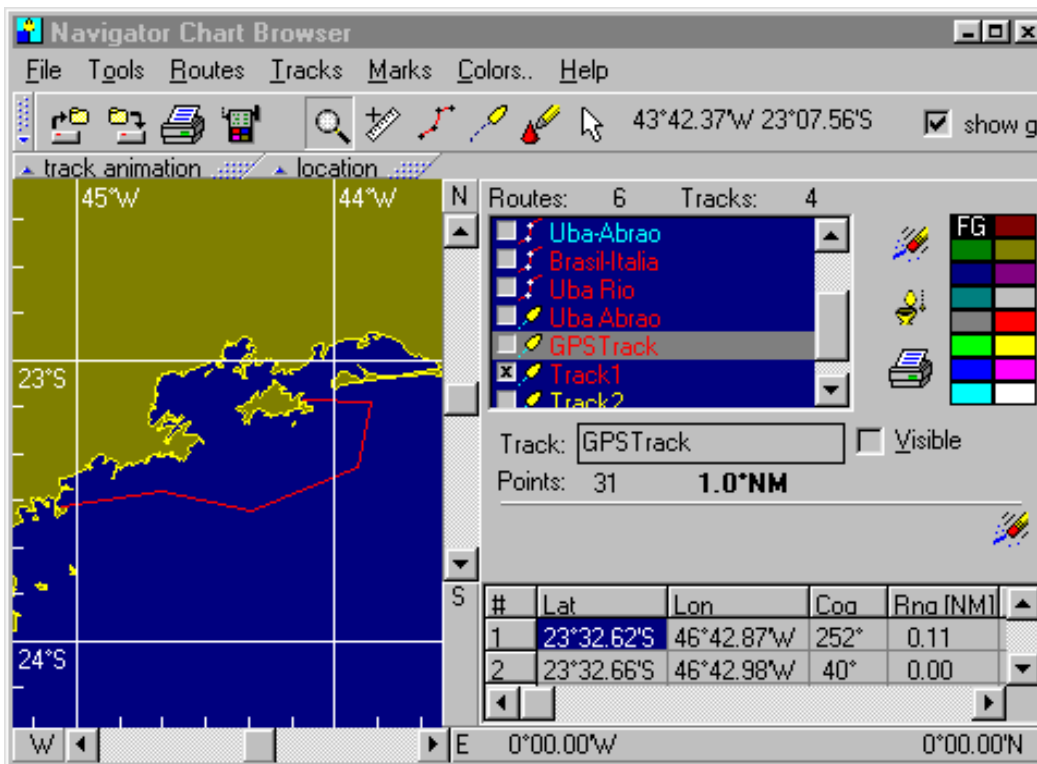

Navigator's vector chart interface

Route - This tool is used to draw routes. A route is a set of points in the surface of the earth, with optional associated text. Routes can have any number of points or waypoints. You can draw as many routes as you wish. Routes can be stored in Navigator Desktop files (.NAV files). You can make some routes invisible and concentrate on your current route. You can also edit routes, change their colors and names.

At anytime you can check the COG and Range between two points of a route, and the total length of a route. To edit a route, click the checkbox "Edit routes/tracks". The route editor will show. You can change all attributes of a route (Color, Name, and Visible). You can also edit coordinates of points, by double-clicking the point in the spreadsheet. To add a point to an existing route (or track), click the route tool. In the menu, select *Routes Add Point* to route. Choose the route. Add one or more points. Right click to save points and end addition.

To create a new route, click the route tool and click the route points. Right click end route. When prompted, enter route name.

Tracks - This tool is used to draw tracks. Tracks are like routes, except that each track point has an associated date/time value. They are used to log the positions on a trip. Like routes, they can have any number of points. Tracks can be stored in Navigator Desktop files (.NAV files). You can make tracks invisible to concentrate on your current track. You can also edit tracks, change their colors and names.

To edit a track, click the checkbox "Edit routes/tracks". The track editor will show. You can change all attributes of a route (Color, Name, and Visible). You can edit point data, by double-clicking the point in the spreadsheet.

To create a new track, select the track tool and click the first route point (left button). If you want, add more points with left clicks. When done adding points, right clicks the chart. Enter track name.

To add a point to an existing track, click the route tool. In the menu, select Tracks Add Point to route. Choose the track. Add one or more points. Right click to save points and end addition.

Marks- You can also add marks to the desktop. Select the mark tool and click one point, specify optional text for the mark and choose a mark icon.

Pointer- Use the pointer tool to point chart objects (islands, tracks, marks etc). If a name is associated with the object, a text will appear near the cursor.

Navigator Desktop files

[▲back to the top](#)

After loading a vector chart and/or raster charts; changing routes or tracks, you can save all to a desktop file. A **Navigator** desktop file contains the state of the chart viewer, including:

- One Vector charts.
- Raster charts (i.e. chart images)
- Routes
- Tracks
- Marks

Desktop files have the extension .NAV, and are in text format.

GPS Interface

[▲back to the top](#)

Navigator has GPS interface. This interface accepts NMEA (National Marine Electronics Association) standard GPS messages. Two kinds of NMEA messages are accepted:

RMC - Transit Specific Navigation information message- This is the recommended (default) accepted message, because it has date and course information. RMC messages give Latitude, Longitude, date, time, course and speed.

GLL - Geographic Position Latitude/Longitude message - Select this one if your GPS does not support RMC

messages. GLL messages have only Latitude, Longitude and time (no date).

Note: The NMEA interface, available in most GPS devices, uses a RS422 hardware interface. This is not the same as the RS232c serial interface, available in PCs. While the 422 interface uses +12/-12V electric signals, the RS232 uses 0/5V. But since the PC uses the level of about 3V to distinguish between 0s and 1s, the connection works fine in most cases. However, they are different things, and you may experience problems connecting them.

You will need a connection cable, which is an optional part for some GPS models. Check your GPS documentation for more details on activating the NMEA interface and selecting the messages. Some GPS devices disable the dataport, to save battery. You probably will have to change the default configuration to enable the GPS data output.

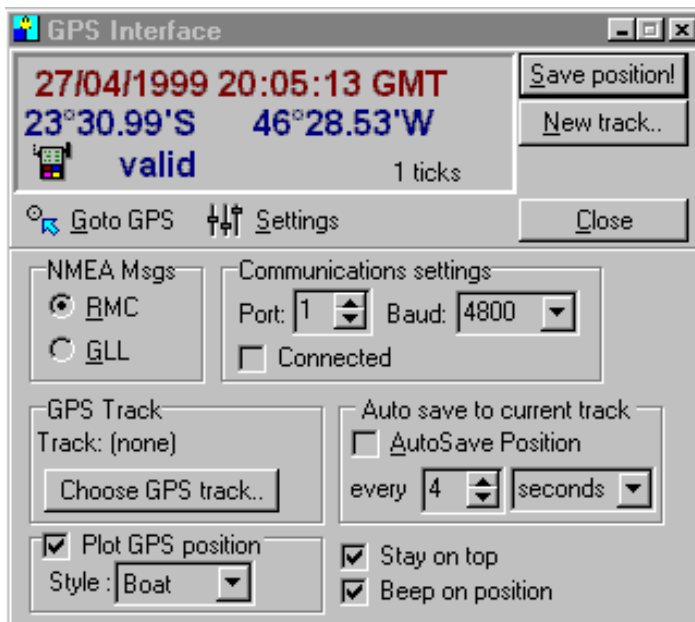

To open the GPS interface dialog click the GPS Interface button. A window will show, with current GPS position. Clicking the *Settings* button will show the GPS settings page, as shown below. Clicking again hides the settings.

- Set the baud rate to the same value as your GPS device. Most GPSs have a default baud rate of 4800.
- Choose computer port number.
- Click the "connected" checkbox to open the communications port and start receiving GPS data.

The upper panel will show the current position, date/time and position status (as reported by GPS device).

The GPS interface can be set to save a position periodically (AutoSave feature). Positions are saved to the current GPS track. A given desktop can have only one GPS Track. Use the "Choose GPS Track" button to choose the GPS track. If starting a new travel, use the "New track" button.

You can also save positions manually, by clicking the "Save position!" button. Just make sure the current position status is "valid".

Tip: If you use RMC messages, Navigator will plot a small boat in the current position, pointing to the actual course. If you use GLL, which has no course information, a square will be plotted.

Troubleshooting the GPS connection

[▲back to the top](#)

PC/GPS connections are sometimes tricky. A problem of either PC or GPS settings will unable the communication.

First, make sure that the GPS device is transmitting data. Stop the Navigator and open the Windows terminal (or Hyperterminal in Windows 95/98). Set terminal communications settings to 4800 baud, 8 data bits, parity None, 1 stop bit. If the GPS device is set correctly, you will see text messages coming from the GPS, like these:

```
$GPRMC,001556,A,2332.648,S,04642.969,W,000.9,045.8,230997,018.5,W*6E
or
$GPGLL,2337.479,S,04718.352,W,235808,V*3
```

The first is a RMC message and the second a GLL. If you don't see any message, the GPS is probably not sending data. You may have to activate the GPS dataport and/or the transmission of each message type (Some GPS devices disable the data port every time they are turned off). After you start receiving one of these messages (choose RMC if available), return to the Navigator and make sure the correct data port, baud rate and NMEA message type are set. You may set the Navigator's GPS interface to beep on each incoming message.

Leg Calculator

[▲back to the top](#)

When planning a route between two points far away (over 1000 NM), many issues must be carefully considered: sea currents, prevailing winds, ship routes, shallow and dangerous areas, foul weather, etc. While these points are very important, there are also geometric considerations: the Earth is a sphere and routes are not straight lines but arcs in the spherical surface. Two kinds of routes are of special interest: the **lines of great circle** and the **rhumb lines**.

A **Line of great circle** (LGC) is the shortest path between two Earth points. This kind of route is contained in a plane defined by three points: the two route end points and the center of the Earth. When plotted in a Mercator chart, a LGC is represented by a curve, and a straight line in Gnomonic charts. While LGCs are shortest, they have a few problems:

- True course changes constantly from point to point.
- Depending on the end points, a LGC can take you to high latitudes, which is sometimes undesirable.

Rhumb lines (RL) are routes with constant true course. They are represented by straight lines in Mercator charts and curves in Gnomonic charts (the opposite of LGCs). RLs are easy to navigate because the course is constant. They are, however, a little longer (the difference is larger in higher latitudes).

Navigator **Leg Calculator** will calculate both LGC and RL routes between the two end points. To open the Leg Calculator, press the calculator button in the toolbar or choose 'Routes, Leg Calculator' in the menu.

Besides distance and course, Navigator shows the difference between the two options and builds routes with specified number of segments.

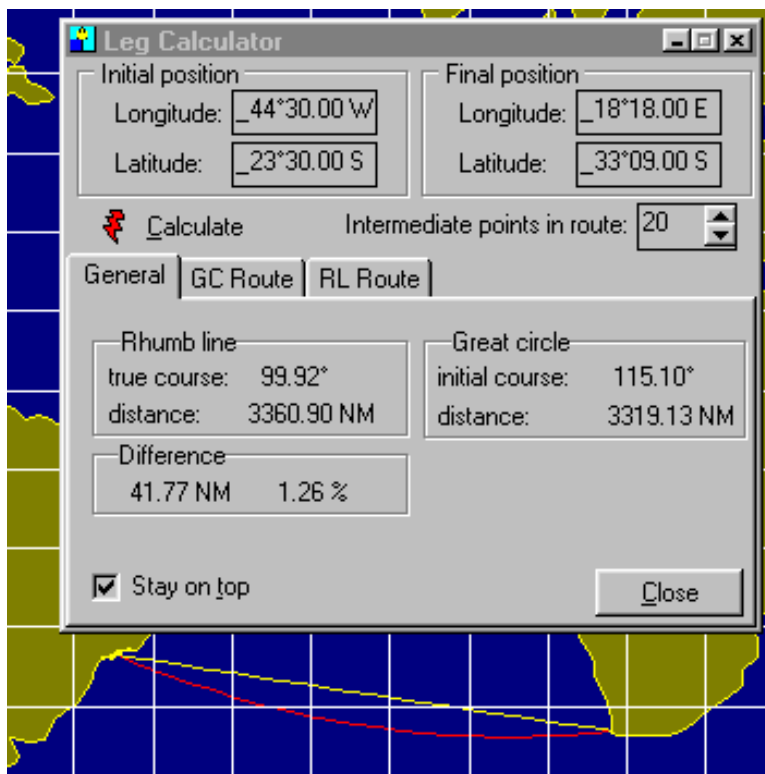

These routes can be inserted in the current desktop. Routes are added to the desktop with names "Rhumb Line" and "Great Circle". You may change these names in the route editor.

In the picture to the left, the yellow line is the RL route and the red one is the LCG (both created with 22 points). The difference between the two is 41.8 NM (1.26%). The LGC route has a crosstrack difference of 241 NM to the RL route (that is, it goes up to 4° south of the RL).

When building the routes, LGC route points are set by the program at constant longitude increments. RL route points are set at constant distance increments.

Chapter 4- ChartMaker program

[▲ to table of contents](#)

The **ChartMaker** program was designed to work with chart images in formats GIF, JPG and BMP, and prepare them for use in the **Navigator** chart viewer.

This program has two main functions:

1. Importing a raster chart images, producing CID files.
2. Making vector charts (i.e. digitalizing points and polygons), producing CHT files.

How it works

[▲ back to the top](#)

A computer image is formed by a large number colored dots - also known as pixels - disposed in a rectangular mesh. If the image is from a nautical chart or satellite photo, an algorithm can be designed to find the real world coordinates of any of these pixels and vice-versa. This is exactly how ChartMaker works.

The first step to make a vector chart or to import a raster chart image is to establish the scale model between the

image and the real world. To do this, you have to click 3 **reference points** and enter their world coordinates (Lat/Lon pair). This is enough to define a scale between the real world and the image pixels.

Technically, when you click the three reference points and enter the Earth coordinates, you are actually defining four vectors: two in screen coordinates (S12 and S13) and two in Earth coordinates (E12 and E13). Since both geometries are similar, for any point P, we can write:

$$SP = S1 + k * S12 + r * S13 \quad (1)$$

$$EP = E1 + k * E12 + r * E13 \quad (2)$$

where:

SP = Screen coordinates of point P

EP = Earth coordinates of point P

S1 = Screen coordinates of reference point 1

E1 = Earth coordinates of reference point 1

r and *k* constants

From relation (1), we can calculate constants *k* and *r*. With these constants, we can calculate the earth coordinates of P from relation (2). This is how the program calculates the earth coordinates of any screen point (and screen coordinates of a Lat/Lon pair).

Mercator Latitude scale correction

[▲back to the top](#)

The method above works for linear latitude and longitude scale charts. But most navigation charts (and particularly the detail charts) are Mercator projections. Mercator projections have a great advantage: distances and courses between points can be measured directly from the chart. Angles are true, no correction is needed.

As any coast navigator knows, distances in these "regular" charts must be measured in the latitude scale, one minute of latitude being one nautical mile. To allow this, the Mercator projection latitude scale is not linear.

If you look at the picture below, you will see that, as latitudes get higher, distance between parallels in Mercator charts expands. The size, measured in screen pixels, of a given latitude minute is proportional to $1/\cos(\text{Lat})$. For instance, when $\text{Lat}=0$, $\cos(0)=1.0$. For $\text{Lat}=60^\circ$, $\cos(60)=0.5$, and so a minute of latitude at this point twice as large as at $\text{Lat}=0$. Of course this "latitude grow" is variable, and integral calculations are needed to calculate the size factor between two latitude intervals.

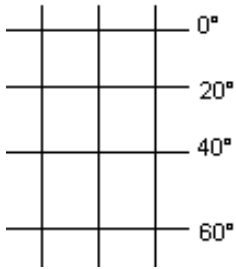

Navigator's screen chart representation is **not** a Mercator chart. The latitude scale is linear and the factor between latitude and longitude axis tick sizes is equal to Mercator projections in the center of the chart window. This is, however, of no consequence, since you are not going to "measure" anything on the screen. You will use programs calculators and measurement tools, which use the mathematically perfect Lines of Great Circle (LGC) for distance and course calculations.

Still, **Navigator** knows how to deal with Mercator chart images. When using a Mercator chart image on the Navigator, remember to **check the Mercator latitude scale checkbox**. The program will correct for the Mercator scale automatically.

Which chart images can be used ?

[▲back to the top](#)



chart 1 - Grid rotated

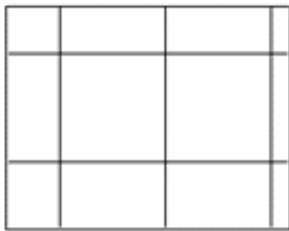

chart 2 - Grid adjusted

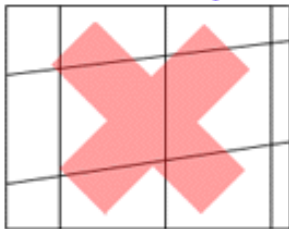

chart 3 - unsuitable skewed grid

- Mercator chart images are OK, even if the image is rotated (like chart 1 on the left). It's difficult to perfectly align a large chart when scanning. **ChartMaker** will rotate the chart in order to align its grid with the vertical direction (chart 2). This is necessary to speed up chart resampling, for displaying.
- Gnomonic and other curved grid projections **cannot be used**.
- Some images (particularly satellite images) are skewed. Their constant latitude and constant longitude lines are not orthogonal (like chart 3 on the left). These images **cannot be used**. After entering the three reference points, Chartmaker will inform you if this kind of problem is present.

Tips for scanning charts

[▲back to the top](#)

- Scan using resolutions between 75 and 150 dpi. Avoid large files (over 1MB GIFs or JPGs). Images will have to be resampled by the Navigator at run time while zooming. Large images will consume a lot of CPU cycles, resulting in poor and bumpy performance.
- When scanning large paper charts, you may detach the page scanner cover (if the scanner allows) to avoid folding the chart. Put some weight over the scanner cover, so that the paper is flat and perfectly in contact with scanner bed.
- If the chart doesn't fit in the scanner bed, scan it in parts, overlapping between them. Then make a CID file for each image. Navigator can display different charts together, and will even allow partially opaque rendering, merging the overlaps.
- Larger scanners (A3) are preferred, when available. A4 scanners are small for large paper charts.
- Hand scanners are not recommended, because they can distort the image scale. Use only page scanners.
- Images should be saved in GIF or JPG format (JPG is usually better).

Choosing the 3 reference points

The 3 reference points indicate how the pixels in the chart image map to the actual world. Care must be taken in choosing these points, in order to achieve a precise scale. Below are some guidelines for choosing the reference points:

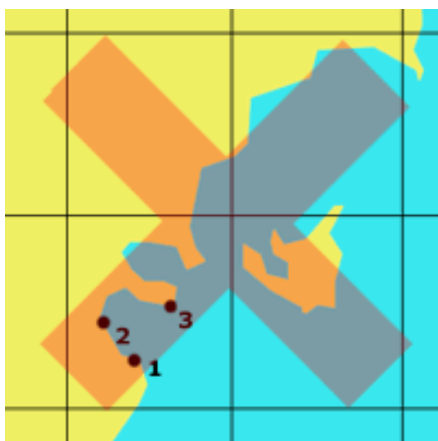

bad points- too close!

Choose reference points that are **as far from each other as possible**. This will result in a more precise scale. If possible, choose points near the corners of the image. In the image on the left, points are too close and the scale will be poor.

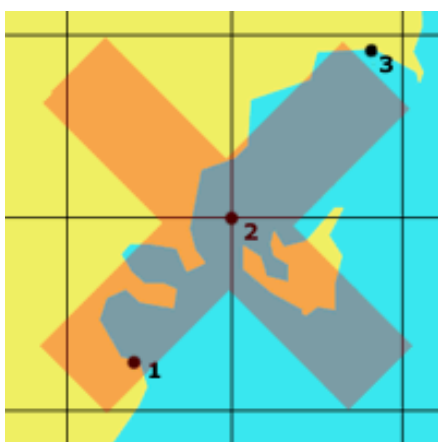

bad points- nearly aligned!

Reference points **must not be aligned**. In the image on the left, points are nearly aligned and the scale will be poor.

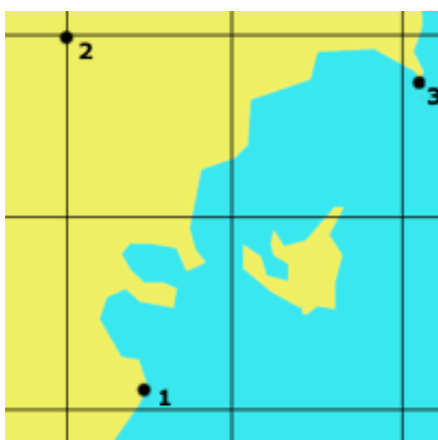

good reference points

In the image on the left, points are well positioned (i.e. far from each other and not aligned). Choose points that are close to the corners of the image, if possible.

If the chart has a grid, the grid line crossings are logical candidates for reference points (like point 2). But other points can be used and they don't need to define a right angle between them.

Importing a raster chart image

[▲back to the top](#)

1. Open the **chartmaker** program and click **Import chart image** and load the image to be imported.
2. Check the **Mercator scale** checkbox, if chart is a Mercator projection (most are).
3. Take a good look in chart and choose the 3 **reference points**, as described **above**. Click each reference point with great care. Inform the precise latitude and longitude for the point.
4. Chartmaker will then calculate the scale and produce a summary, rotating the image as needed (rotation is considered necessary if the angle between a meridian and the vertical is larger than 0.001 rad).
5. If the image was rotated by ChartMaker, you must save it. I use to save the image with a different name, keeping the original scan intact, but you may save with the same name, overwriting the original.
6. If you made any mistake or if the image is unsuitable for use, the summary will inform you of this. You may try again, if you think the image is suitable and you made a mistake.
7. After the summary, you can click extra points in the chart. This is optional, but highly desirable, to further check if any error was done in the reference points.
8. If everything is OK, save the **CID** file (Chart Image Definition). This text file contains the information for the Navigator program to use the image: the reference points data, image file name and description.
9. The CID file also contains the image digital signature (of type MD5). This is to make sure that the associated image is unchanged. So, if you do any changes in the image - even changing a single pixel color, the CID file will become invalid. This is a **security feature** to avoid accidental image change.

Making vector charts

[▲back to the top](#)

While raster charts are very complete, with the all relevant navigation information, vector charts consume less memory, are a lot faster to draw and are "zoomable". This is why is interesting to have a vector chart to be loaded underneath the local raster charts.

Navigator uses a custom chart file format, with the CHT extension. These are plain text ASCII files and can be edited with the Windows Notepad or Wordpad. Because providing detailed vector charts of all regions of the Earth is a demanding task, I choose to give users a tool to roll their own charts. Producing a vector chart means using a raster chart image to digitalize the points in the shoreline.

Chartmaker accepts three image formats: Windows BMP, GIF and JPG. If you are scanning paper charts, JPG is probably the best format, because files are smaller. It's a compressed format.

The CHT file

Once you have the image of the chart, load it in Chartmaker. Now you have to define the scale for this chart. Click and enter the Earth Coordinates for three distinct **reference points** of the image, as described **above**.

1. Choose three points that are relatively distant to each other (at least 1/3 of the screen). Select points that form a right angle. Click the points and enter their Earth coordinates.
2. After the third point, the caption will show the coordinates of the cursor, as you move the mouse. Check the coordinates of other points, to certify that your scale is accurate.
3. Select "Edit, Draw Axis" in the menu. The program will draw vertical and horizontal axis in 30' intervals.

Check if they are the same as the image's axis. Draw again to erase the axis.

4. Now draw the shoreline, clicking the points with the mouse. Draw different polygons to represent the islands and continents.
5. After clicking all points of a given polygon, press the "close polygon" button. The last point will be connected to the first. All polygons must be closed.
6. Give a name for the polygon.
7. After drawing all the polygons, save the **CHT** file.
8. Open it in Navigator chart viewer, to see the result. Zoom in and out, to check the details.

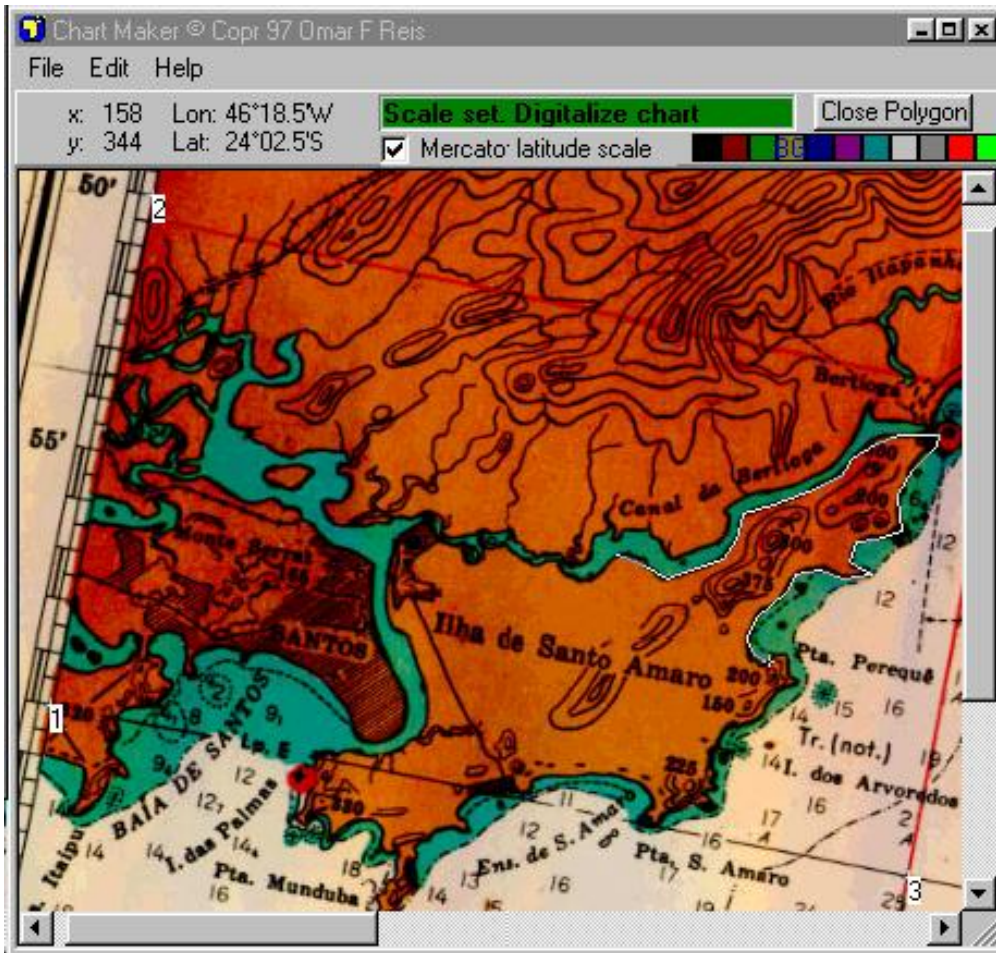

In the figure to the left, the 3 reference points are marked 1, 2 and 3. The coordinates are:

- 1) 24°00.0S 46°25.0W
- 2) 23°50.0S 46°25.0W
- 3) 24°00.0S 46°06.6W

If you open the supplied **myworld.cht** file in Navigator, you will see a simplified chart of the whole world. I made it more detailed in one part (44°00'W 23°30'S), the region I usually navigate. You can do this for your region, by directly editing the CHT file with a text editor and adding the polygons of your region. This is a little tricky. You might prefer to roll a chart of your region only.

You may also merge CHT files, using an ASCII text editor (like the Notepad or Wordpad). Take a look in the CHT file header for more technical details on the CHT file format.

XXX

(c) Copr. 1991-2001 Omar F. Reis - All rights reserved

Apparent Movement of a Star

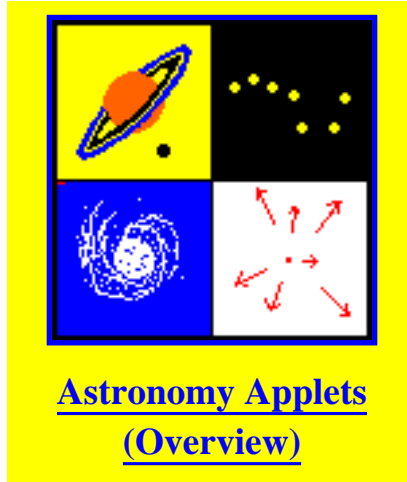

URL: <http://www.walter-fendt.de/a11e/starposition.htm>

© Walter Fendt, February 11, 1999

Last modification: January 18, 2003

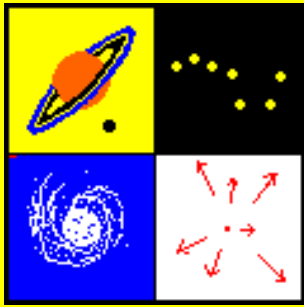

Java Applets on Astronomy

Walter Fendt

English version

www.walter-fendt.de/a14e

(Java 1.4, 3 applets, latest version)



www.walter-fendt.de/a11e

(Java 1.1, 3 applets, 2003-01-17)

[Download](#)

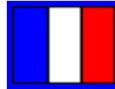

Spherical Astronomy

[Celestial Poles](#)

07/12/1998 - 01/17/2003

[Apparent Movement of a Star](#)

02/11/1999 - 01/18/2003

Stars

[The Brightest Fixed Stars](#)

04/19/2001 - 01/18/2003

Walter Fendt, January 18, 2003

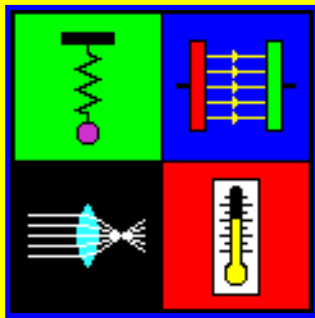

[Physics Applets](#)

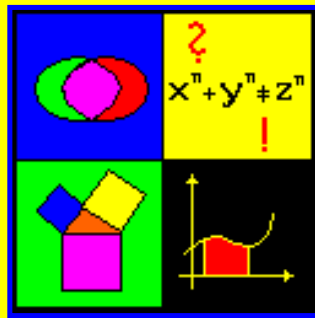

[Mathematics Applets](#)

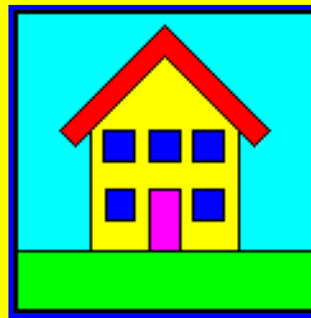

[Homepage](#)



[E-Mail](#)

[Copyright](#)

Book Categories:

- Celestial Atlases & Catalogs
- CCD's & Astrophotography
- Handbooks
- Math & Celestial Mechanics
- Photoelectric Photometry
- Almanacs
- Telescope Making & Optics
- History of Astronomy
- Navigation
- ON-LINE ORDERING
- HOME
- WHAT'S NEW
- SOFTWARE
- SOFTWARE UPGRADES

Math & Celestial Mechanics

Click on book cover for a more detailed description of the publication.

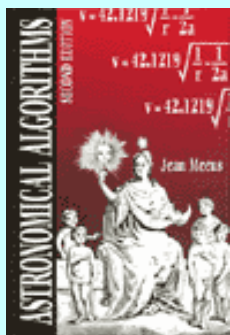

Astronomical Algorithms
\$29.95



Astronomical Formulae For Calculators
\$14.95



Astronomical Tables Of The Sun, Moon And Planets
\$24.95

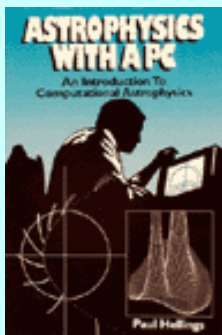

Astrophysics with a PC
\$19.95



Canon of Lunar Eclipses
\$29.95

Computer Canon Of Lunar Eclipses
\$29.95



Computer Modeling: From Sports to Spaceflight... From Order to Chaos
\$34.95

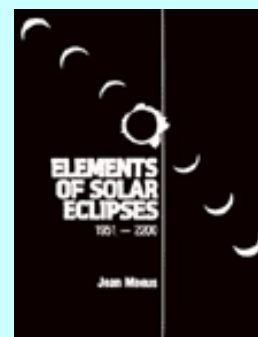

Elements of Solar Eclipses 1951 - 2200
\$19.95

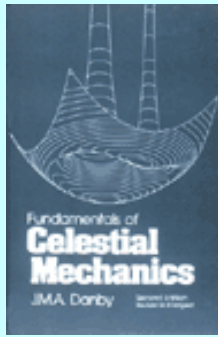

Fundamentals of Celestial Mechanics

\$29.95

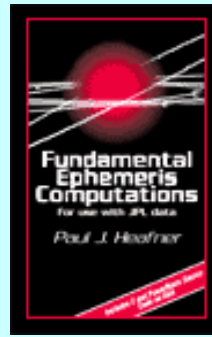

Fundamental Ephemeris Computations

\$29.95

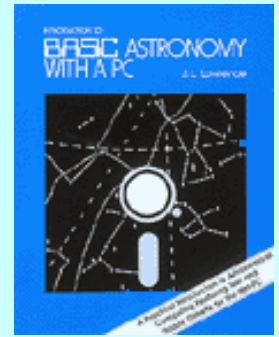

Introduction to BASIC Astronomy With a PC

\$19.95

Low Precision Formulae For Planetary Positions

\$5.00

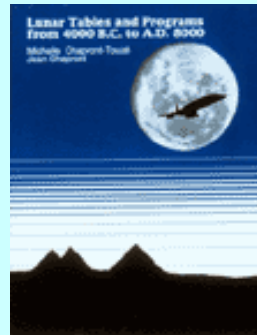

Lunar Tables and Programs 4000 BC to AD 8000

\$19.95



Mathematical Astronomy Morsels

\$24.95

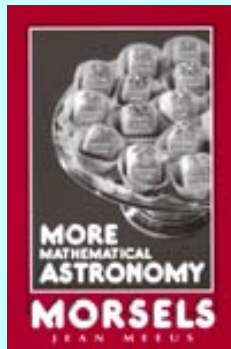

More Mathematical Astronomy Morsels

\$24.95



Methods of Orbits Determination

\$24.95

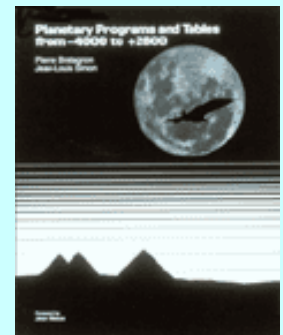

Planetary Programs and Tables -4000 to +2800

\$19.95

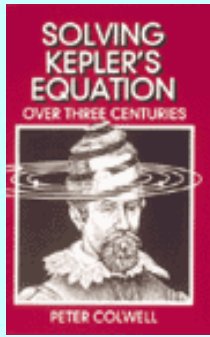

Solving Kepler's Equation

\$29.95

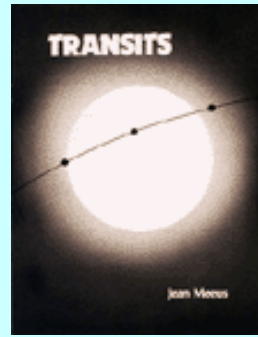

Transits

\$14.95



The Orrery: Computer Models of Astronomical Systems

\$29.95

THE EUROPEAN WEEK FOR SCIENTIFIC AND TECHNOLOGICAL CULTURE 1996

ASTRONOMY ON-LINE



*The World's biggest
Astronomy Event on
the World-Wide-Web*

COLLABORATIVE PROJECTS

Final Event - The Polar Star.

Here follow detailed instructions about the measurement of the altitude of the Polar Star (also known as the *North Star* and *Polaris*) above the horizon - the first method within the **Astronomy On-Line** Final Event that you may use to determine your geographical latitude.

Where do you live ?

It is fairly easy to find the North-Star - if you do not know it, click here to see a [finding chart](#)

The North Star has the advantage it stays fixed in the sky - all night long - as illustrated here :

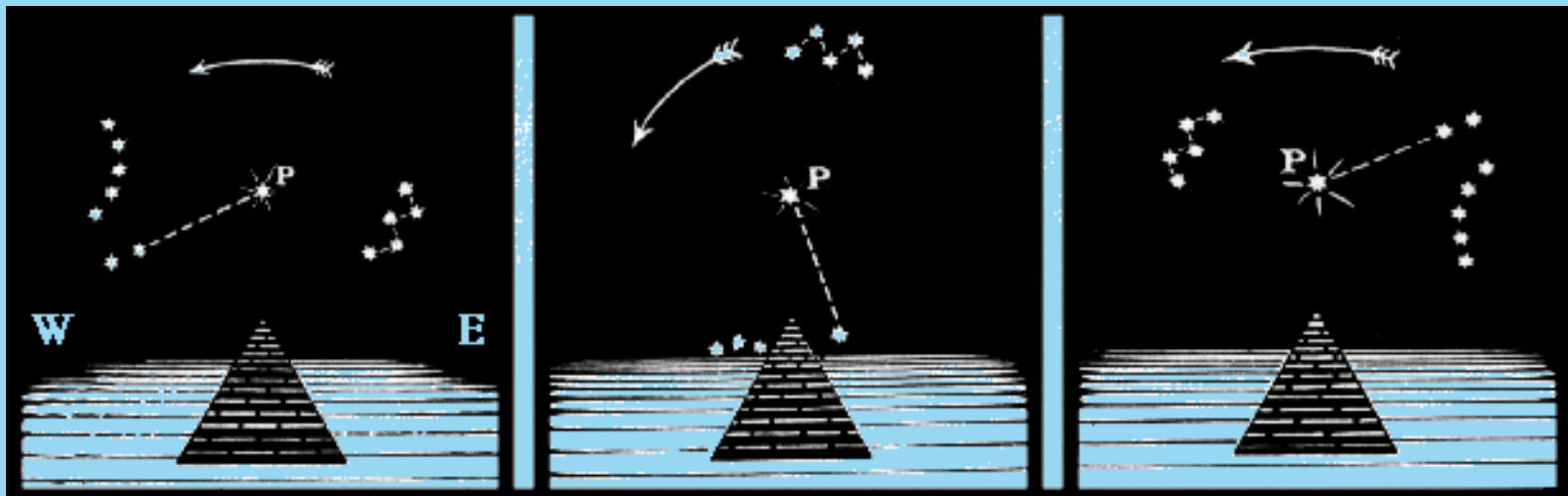

Movement of the Stars during a typical Night

[Figure 1](#)

On these Figures you will see the well-known constellation **The Big Dipper** - in the opposite corner of the last Figure, you may find **Cassiopeia**. The star Polaris is right in between.

This North-star has **two** advantages, known since ancient times.

- First of all, it tells the direction of accurate North.
- Secondly, it may in an easy way tell your geographical latitude

Note that the Geographical Latitude is 0 deg at Equator, and 90 deg at the North Pole.

Geographical Latitude

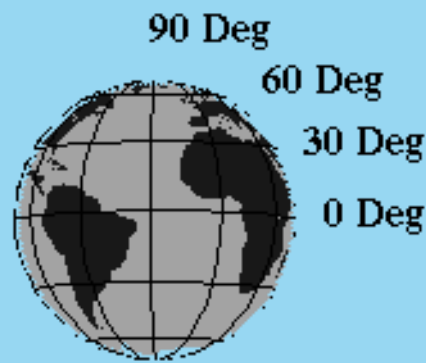

[Figure 2](#)

An easy exercise

- Find your latitude on a globe.
- With a bit of [North Star Trigonometry](#) it is possible to show a simple relation :

Your Geographical Latitude = Height of North Star above horizon.

So, if you live in, say, Paris at 48° North, Polaris will be 48° above the Northern horizon.

Put in another way - the North Star Polaris will be placed high on the sky when viewed from the Arctic (90° from the Pole):



Figure 3: taken from "Elementary General Science", Toronto 1935 - by G. H. Limpus and J.W.B. Shore. Click to obtain larger figure (GIF, 35k).

Some history

During the Middle Ages, every Christian man with self-respect should visit Jerusalem at least once during his life.

Bishop Nicolas from Iceland published a method to determine the altitude of the North Star and thereby to determine the geographical latitude in 1150:

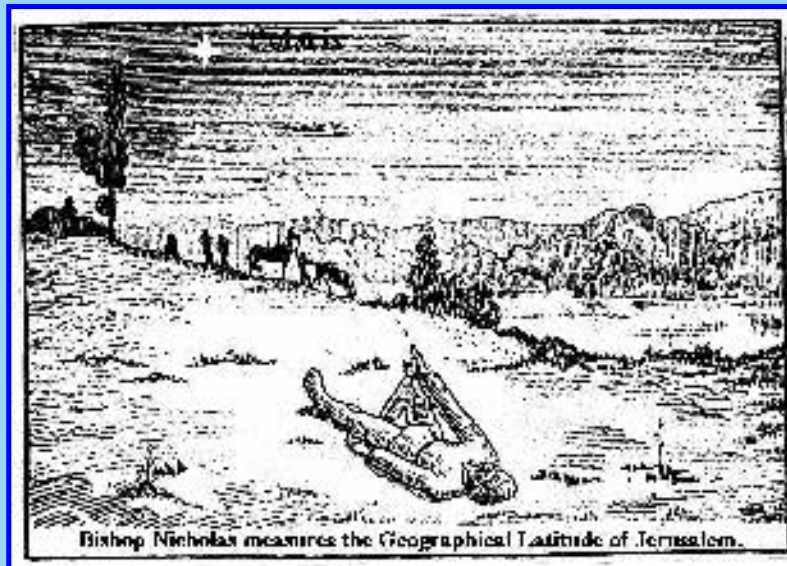

Figure 4. Click to obtain larger figure (JPG, 85k)

This method works the following way: Lie down on the ground and put your right hand above the knee, as shown on the picture. When the North Star is right above your thumb, then you have arrived at the latitude of Jerusalem.

Another exercise

[Check Bishop Nicolas' method with your school-fellows.](#)

Measure the altitude of the Polar Star

Now we are ready to measure the height of our polar star ourselves.

There are several ways to do this, first of all by means of the **astrolabium** - an instrument applied by Columbus during his voyages to America:

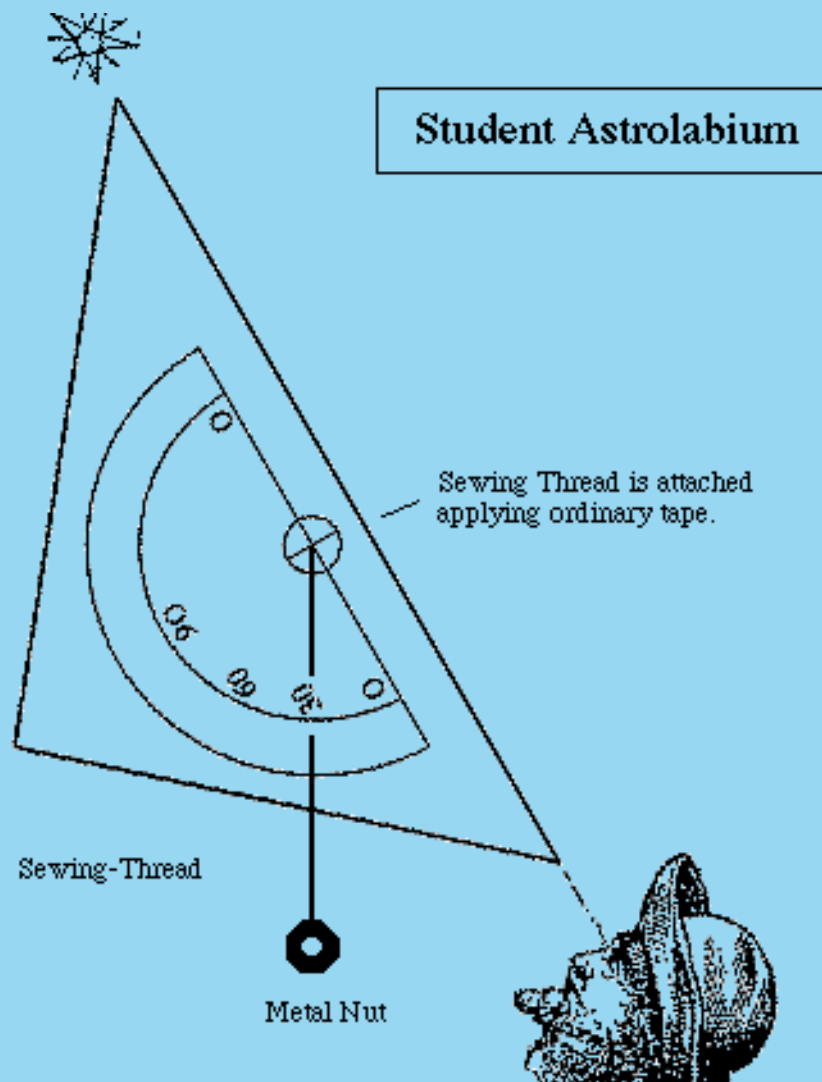

Figure 5: A simple astrolabium - based on what you may find in any school

Measure the height of Polaris applying the equipment above. You merely have to point the long side of the triangle towards the Northstar. Having done this, put a finger on the sewing thread and move into your house. Standing in clear light, read the number and write it down.

Please observe - if you apply a protractor-device like above - it will not show the altitude directly, but instead it will show $z = (90 - alt)$.

So, if the measured angle above is say 32 deg, you live on $90 - 32 = 58$ deg latitude.

Not all explorers applied the astrolabium, some applied the Jacobian Stick:



Figure 6: The Jacobian Stick

Construct such a device and calibrate it. Ask your math-teacher how to do so.

The Jacobian device had the disadvantage of being a bit clumsy - it is difficult to keep an eye on both a star and the horizon. If you construct this instrument - beware - don't fall while you are aiming it out in the dark !

A much more handsome device was presented to Vasco da Gama (1469-1524) by native sailors outside India. This device is called a "**Kamal**".

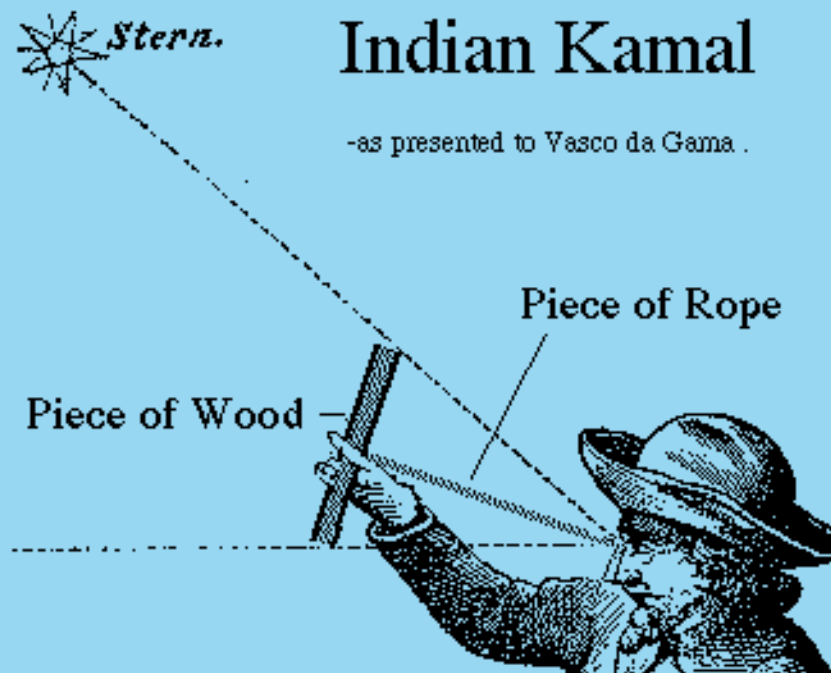

Figure 7

The Kamal is far more easy and handsome compared to the Jacobian Stick. Notice, you only need a piece of wood - and a tiny rope. Pull the rope - until the wooden piece fills your field of vision from the horizon up to the North Star.

Sailors off the shores of India marked the different cities simply by tying a knot.

Today, sailors apply a sextant or similar device. Mostly they do not look for the North Star, but instead look for the Sun during daytime.

However - the Danish sailor and author Troels Klovedal once rescued an American shipwrecked sailor off the coast of Bermuda. This sailor had navigated his lifeboat for weeks - by means of the North Star. Keeping an ordinary pencil in outright arms distance - he tried to keep the same latitude all time. This made him stay within the ordinary shipping routes - were he was later picked up by Troels Klovedal.

So, once again, stay awake during the astronomy lessons - it may actually save your life!

Have a nice Hunt! - and don't forget to report your results!

Note

Figure 4 is courtesy of **Soren Thirslund** - Naval Museum, Helsingor - permission to reproduce only if AOL and Soren Thirslund are mentioned. Soren has written several interesting books on navigational history - some of them are to be published by the Conway Maritime Press - London. Soren Thirslund would appreciate a feedback.

Author: [Mogens Winther](#)

Amtsgymnasiet Sønderborg
Gruntvigs Allé 66
DK-6400 Sønderborg

[Astronomy On-line](#) | [EAAE](#) | [ESO](#) | [Help](#) | [Search](#)

[Send comments to <Richard.West@eso.org>](mailto:Richard.West@eso.org)

Last update: Nov 19, 1996



Welcome to our collection of children's online astronomy activities.

In the following six chapters are hundreds of fun explorations into astronomy as a classroom tool for learning how to theorize, experiment, and analyze data. The activities are fully illustrated and contain detailed, step-by-step instructions as well as suggested discussion topics. This book is lots of fun for teachers and students alike.

This site contains the complete text and graphics of the collection along with related links, a table of contents, an explanation of how to use this book, and email links to the authors. We do hope you enjoy these adventures in astronomy as much as we enjoyed designing them.

[Table of Contents](#) | [Everyday Classroom Tools](#)



Selected as a Valued Internet Site
for the Discovery Channel Online



This site is best viewed with Netscape Communicator. Download Netscape
Now!

CHOOSE

Copyright © 1996 Smithsonian Institution
These pages designed by Tania Ruiz. Last updated September 9, 1998.



Practicality aside, being able to read and understand a map is an important analytical skill. Mapping has been a part of our lives since the very first explorers set forth to chart the lands beyond their countries. After centuries of such adventures, very little of the Earth's surface is yet uncharted. Orbiting satellites also have been making many detailed maps of the Earth's surface. However, much of the most exciting mapping being done today happens from our explorations away from the Earth! Several robotic space missions have traveled to other planets to map their surfaces. Most recently, the Magellan space probe which orbited Venus made a detailed radar map of its terrain, obscured by Venus' thick atmosphere. The CfA Redshift Survey is a project of over a decade which is mapping the galaxies of the entire Universe!

Whether a map is of a classroom, a city, a planet, or an Universe, the same basic knowledge is required to understand the information it contains: scale, orientation, angles, and measurement. In this chapter, we practice reading maps, first of our nearby surroundings, then of our town, and then of the Earth and stars. We begin this topic by using maps, then learning how to make our own.

Topic 1: Reading Maps

Whether to get across town or across the world, maps are crucial for navigation. They

can help us discover the distances between objects and their relative orientation to one another.

The ideas of following direction and relating to a two-dimensional representation of a landscape are to be introduced first with a fun scavenger hunt. The chapter will then move on to political maps, and then see how topographical maps describe terrain.

Activity 4-1: Scavenger Hunt

This activity is best suited to younger students.

Scavenger hunts are always fun, but in this hunt, the rewards include not just the "goodies" found on the course, but also the skill of following a map.

Materials: An interesting, yet safe and supervised, course for the hunt; a simple, handmade map of the course; small prizes like toys, trading cards, booklets of stories, etc.

- 1. Lay out the course for the scavenger hunt on a field or playground. Make a map with the locations of the goodies. Be sure to include enough reference points like buildings, trees, rocks, and playground equipment. ([sample map](#))
- 2. Split the class into small teams and give each student a map of the course. It would be best for the "hunt" to be non-competitive, so plan different maps for each group with different treasures— even if they cover the same area. The focus should be on the map, not the clock or the other teams.
- 3. Discuss the map with the students to eliminate any areas of confusion, and let the hunt begin!
- 4. After the hunt, make sure all of the treasures were found. If one was missed, analyze the map containing it with the entire class, and go find the missing booty.

Discussion

Were the students able to find all of the goodies? Could they find all of the reference

points? Which ones were easier to find? Were they able to find topographical features like hills. Would compass directions help? What about distant landmarks? What makes a good map? What should a map convey? Are all maps meant for the same purpose? How might the map had been different if the students were driving cars or flying planes instead of walking around?

Activity 4-2: Follow a Map of the Town

This activity may be done in small groups.

Instead of looking at a map of a small area, like the playground, we will look at a larger area: our home town or city. See how many landmarks the students can find. Can they find where they live? Can they find their school? You should make a list of places for each student or group to find. The type of places which can be found depends greatly on the type of map available.

Materials: Road map of city or town; list of places, landmarks, or streets to find; rulers.

- 1. Find a good map of the local area. It can be any kind of map: political, road, sight-seeing, etc. The town or city hall or the local Chamber of Commerce may be able to help. You could also find maps to photocopy in the school or public library.
- 2. Make a list of places which each student or group should locate, such as the town or city hall, public library, police station, barber shop, pharmacy, etc.
- 3. Give a copy or portion of the map to each student or group. How many of the places can they find? Can they find where they live?
- 4. This is a good place to introduce the concept of "scale". Show the students where the scale is on the map and what it means. Provide rulers so they can practice measuring and determining distances. When the students have found some locations, ask them how far it is between any two of them.

Discussion

If one map has a scale of "1 inch = 1 mile" and another has "1 inch = 10 miles", which map covers more area? Which map can show more detail? Is a map with more detail always better? What kind of information might a political map have which a topographic map might not? What kind of information would a nautical chart have? Can anyone think of a problem with making a map of the entire Earth? Hint: is the Earth flat like the map?

Activity 4-3: Topographic Maps

This activity assumes you are in the United States, but similar surveys and maps exist in other countries as well.

In 1960, the federal government conducted a complete topographical survey of the United States. The commission responsible for this survey, the United States Geological Survey Commission, has field-checked and updated the Survey several times in the years since. The Survey maps show features of the land, like lakes, ponds, rivers, and streams, and man-made landmarks like permanent buildings, roads, churches, graveyards. They are very detailed, being of the scale 1:24,000; one centimeter on the map represents 24,000 centimeters (240 m or 0.24 km) on the Earth (in English units, one inch represents about 0.38 miles). Neither the roads nor the buildings are labeled, however; these maps are intended to record surface features, especially variations of altitude. To do this, there are contours drawn on the maps, to indicate 10-foot variations in altitude. As a result, these maps are able to convey a sense of the three-dimensional lay of the land. In this activity, we will compare the Survey maps with the land they represent.

Materials: Topographic map available from the U.S. Geologic Survey (details below).

- 1. Obtain a Survey map for an area around or near the school where the class can visit for an hour or so. The Survey maps may be available in nearby public or college libraries. They are also available for \$2 each from the United States Geological Survey Commission, Denver, Colorado 80225.
- 2. Make a photocopy of the map or parts of the map for each student. Discuss the

various symbols and the contours. Make a list of obvious geographic features on the map which should be apparent at the site.

- 3. Visit the site with the class. It can be the school grounds themselves, or somewhere near enough for a field trip. See how many of the features on the map are apparent at the site. Did the map help to visualize the site before the visit? Try to find a feature at the site which does not match the map. Why might this be?

Discussion

Who might use a map like this? Is it a good road map? Does it should political boundaries like precincts, counties, and states? What sorts of uses would this map have that, say, a sightseeing map wouldn't? Why bother recording altitude? Can you think of way other than contours to record it? If the contours on a hill are closer together, does that mean the hill is more or less steep than one whose contours are farther apart?

Topic 2: Making Maps

Now that the students have had some experience using and interpreting maps, the next logical step is to try to make some. We'll start small- literally - by mapping a small, familiar area, the classroom. We'll then venture outside and map the school grounds.

Activity 4-4: Making and Using a Trundle Wheel

It is suspected that in the making of the precise dimensions of the Egyptian Pyramids, architects used a device known as the trundle wheel. We have often used rulers or meter sticks to measure distances, but this requires several steps: placing the ruler down, marking the far end of the ruler, lifting the ruler up and putting the close end on

the mark, marking the far end, etc., until the distance is measured. Even using a flimsy tape measure requires several people to hold one end firm, to keep the tape from flipping, to measure the end, etc. The trundle wheel, however, relies on the simple fact that a circle with a known circumference can be used as a ruler. The circumference is the distance around any circle. Take a string one foot long and bring the ends together to form a circle -- the circumference of this circle is one foot. Rolling a circle with a known circumference along on its edge and counting how many times the circle can go around will tell you how many feet make up that distance you rolled it.

Materials: Big pieces of cardboard (a movers box is fine), scissors or blade, meter stick with hole at end or strong, narrow piece of cardboard resembling such, brass fasteners, dark marker, ruler and a drawing compass

- 1. Making circles of different circumferences requires knowing the radii of the circles. The relation, $\text{Circumference} = 2 \times \text{radius} \times \pi$ is used. We've figured out circles for circumferences of 1 foot, 3 feet, and 18 feet by calculating their radii. These

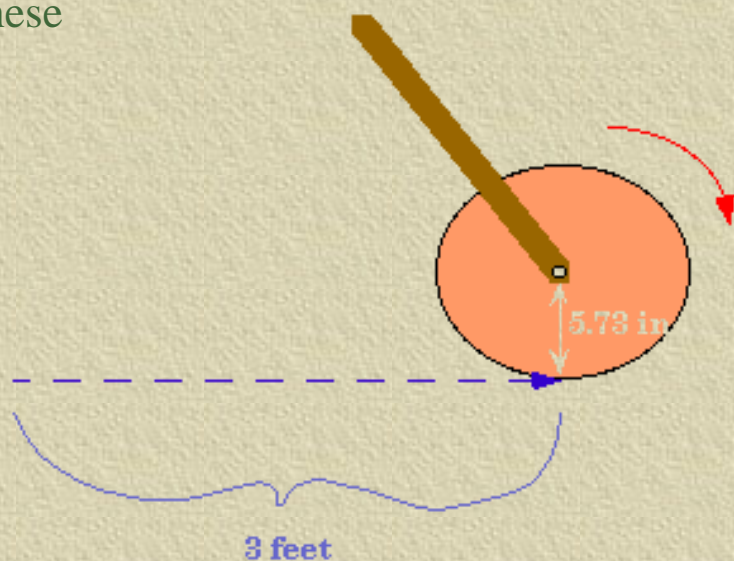

trundle wheel sizes are convenient for measuring distances as big as rooms or as small as the distances between desks. For the 1 ft trundle wheel, spread the two legs of the compass such that one end points to the zero line on the ruler and the other lines up with a little less than 2 inches (the radius). Lock the compass if you can, otherwise, be careful not to accidentally readjust them. Firmly stick the pin end of the compass into the cardboard and swing the pencil end around on the cardboard outlining a circle.

- 2. Carefully, with scissors or with a blade, cut out the circle. With a dark marker,

make one straight line connecting the center to one edge of the circle. This will help you count how many circumferences the wheel has traveled.

- 3. To the center of the circle in the compass pin hole, fasten one end of the meter stick or the cardboard strip with a brass fastener.
- 4. Repeat those steps for the 3 ft circumference circle, but spread the compass points to a little less than 5.75 inches. The 18 ft circumference circle requires a bit of string cut to 2.87 feet. One end of this string is held firmly onto the cardboard while the other end of the string is pulled taut and held with a pencil. By swinging the string around on the cardboard and marking with the pencil where the end of the string meets the paper, you will have another circle to cut out. Then follow the rest of the steps to make it a trundle wheel.
- 5. Start measuring by lining the marker line pointed down with the ground where you want to begin the measurement. Roll the wheel along, counting how many times the marker line hits the floor. NOTE: Because the shape of the circle is a problem for reaching into corners of the room, simply start room measurements with the wheel edge touching the wall and roll to other end of the room until the wheel touches the other wall. Since from the edge to the center of the wheel is defined as the radius of the wheel, and since you had to line the wheel up with the edge twice, add twice the radius of the circle to any measurement made from corner to corner.
- 6. Practice measuring the size of the blackboard, the length of the room, the distance to first base on the kickball field, the height of students in the class. Compare the measurements with those gotten from laying down meter sticks.

Discussion

Are the trundle wheels easier to use than the meter sticks? Are the measurements different? Can students make their own wheels of different sizes using the circumference relationship to the radius? What are the advantages and disadvantages of the trundle wheel? Can students think of other shapes which might be good measuring tools?

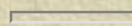

Activity 4-5: Mapping the Classroom

For our first mapping exercise, we'll start small- literally- by mapping the classroom. First we'll examine the room, and discuss the objects in it. Then we'll build a scale model on a large sheet of paper. By tracing the objects we've placed on the paper to represent things in the room, we will have created our first map. The students can then develop a key to represent all of the objects in the room, and then they can make their own versions using their key.

Materials: Trundle wheels or tape measures; small wood scraps (enough of uniform size and approximate scale to represent desks, etc.); large chart paper (cut from 3-4 foot roll); rulers; pencils; markers; 9"x 18" white construction or oaktag paper; stencils of small shapes.

- 1. Students should measure the sizes of the classroom and sizes of a few major pieces of furniture.
- 2. The class should sit around the chart paper cut about 9 x 4 feet. This paper represents the floor of the classroom and on will be placed representations of the objects in the classroom. Mark the length and the width of the classroom.
- 3. Look around the room and discuss the objects in it. Which objects are the same size? Which is the smallest? Are all of the objects the same shape? Students can make up a key which could be useful to themselves or others for this map and include it. For example, all desks could be represented by squares, chairs by circles, and so on.
- 4. Students can start mapping by arranging blocks of wood on the chart paper to represent the various pieces of furniture in the classroom. It may help to start with a few reference points such as the teacher's desk and the classroom door. When students have completed placing the blocks, they should trace the outline of each block onto the chart paper before putting them away.
- 5. Working either alone or in small groups and using the large chart paper as a guide, each student should then make his own map of the classroom on construction paper or oaktag. Rulers should be used to make straight lines and stencils to make circles, squares, and rectangles. How can they draw these objects so that the map will look like their classroom? If they show this to their parents, will they know how to locate their desk when visiting? What other information will this give to others? How could they improve the map? How can they make it look attractive?

- 6. Older students should try to represent objects to scale, perhaps using graph paper.

Discussion

What reference points were the most helpful when starting to map the classroom? Why? How does a key simplify making the map? Would it be more or less work to try to capture the distinct shape of each and every piece of furniture? When might it be necessary to record each shape? How does scale help one make sense of a map? Classes from different rooms could team up, exchange maps, and try to find their partners' desks. Visiting parents could try to use the maps to find their children's desks.

Activity 4-6: Perspective and Reference Points

As students begin to make maps, the importance of scale and perspective become clear.

Materials: Teddy Bear or any suitable objects; large picture; variety of different size balls; paper; markers; blocks; construction paper, 18"x 24".

- 1. Have the students look at the teddy bear on a stool in the center of the room. They can draw it and compare perspectives. Move the students so they view it from a different perspective. How does this affect what they see?
- 2. Students look at a very large picture which has been divided into four numbered quarters. They work in four groups, each student drawing the assigned section of the picture in a variety of paper sizes. When the student finishes, he finds a person from each of the other groups and they put them together. Students may analyze the results and find another way to work together to do a better representation.
- 3. Place various balls on a table. Darken the room and shine a light on the balls. Have students move around the table viewing the balls. They can stoop down low or stand up high on a chair to gain different perspectives. They may then discuss how these objects looked from a variety of reference points.

Discussion

How does measuring with tools help us to make a map? Does it make any difference where you stand when you make a map? Do objects look smaller from one place than from another? How does this effect your map? How can this help students in their map making? If students make another map of their playground (Activity 4 of this topic) will they do it differently? How can they use the measuring reference points in making maps? Would it change the way you made a map if you stand in another place to make it? How can you devise a system to represent the area and the objects in it so that they will be the same relative size or scale on your maps?

Activity 4-7: Mapping the School Grounds

The move outside provides students with different mapping challenges; scale, elevation, and topology take on added importance. Students learn by developing their own techniques for showing these; only when they have experienced this, they will benefit from materials for measurement of elevation such as large rods and levels. Through representations they will increasingly see the relationships between the three-dimensional world and the two-dimensional symbols which represent it on their maps.

When mapping a large area outside, such as the school yard, what tools will help you to make a map? Can you show how far away objects are after you measure them? Does it matter if you move around or should you stand in the same place? How can you use the compass to help you place objects? How can you represent directions accurately? How could you show the hilly parts of the land.

Materials: Large sheets of paper (one for each group of two students), with outline of school grounds and a few key features; pencils; measuring devices; yardsticks; trundle wheels, string; directional compasses.

- 1. Students should work in pairs standing in the center of the school grounds. They should measure and record the distances and directions to different objects on a map.

- 2. The students should discuss and compare their maps with the others. Do the maps look the same? If not, what makes them different? Are some distance determination techniques better for some objects (or some distances) than for others?
- 3. Students should note differences in topography and find a way to represent these differences? What else might help them to do this?
- 4. Students may wish to use materials such as clay, sand, or blocks to represent elevations. This may help them to find a way to represent these area on a two-dimensional map. How many ways can they show this change in terrain? Could colors, shapes, different kinds of lines show height?

Discussion

Students discuss their results. Were their maps similar? What problems did they encounter? How did they represent changes in elevation? What about various surfaces? How did they established directions? What kind of symbols did they use?

Activity 4-8: Mapping the City or Town

The step to mapping a larger area is the next in our investigation of mapping. Representing one's school and playground on a large map allows students to trace their routes to school by moving model cars and buses on the map. The streets represented may lead to major buildings such as libraries, fire and police stations, and town and city halls. Directionality may be established and a compass rose included in the map. Students may work from a map of their town which has been enlarged and then enlarge that again. Students may map a route to a playground or other area of interest and then walk that route together.

How could students help to map an area when the whole area cannot be seen? What materials would be helpful to use in making such a map? What unit of measure would be appropriate to use? If the school is the focus point and placed at the center of the map, how could students represent it? What other buildings would they want to represent on this map? What about other areas of their town? How could they make a very large map even large enough to walk on? How could they determine directions?

Materials: One large sheet (3'x 8') of heavy paper from standard 3' roll for each group; wide tape; yardstick; pencils; markers; photographs of buildings; large piece of heavy plastic to cover map; blocks of wood; map of students' town or city (enlarged to largest size possible on large capacity copy machines); plastic figures and cars; oaktag; glue.

- 1. Students discuss their school location and its proximity to other areas of interest in their town or city. They decide which buildings, areas and landmarks are important to include in a map of their area.
- 2. Students see a map of their town or city. This can be placed on the floor and students may sit around it. They look for their school and discuss the surrounding area such as streets and parks. They locate other buildings of importance and note the relative distance to their school. They discuss making a larger size map.
- 3. Some groups may want to work on streets and others may want to show playgrounds and ponds or lakes. They use markers to color the map. Three dimensional buildings may be made by drawing a building on oaktag. Cutting it out and standing it upon the fold at the bottom and supporting it with a strip of oaktag. These may be glued to the map.
- 4. When the map is finished, all students gather around it sitting in a circle and discuss this map and the experience shared in making it. They may add a compass rose. How is distance represented?
- 5. Discuss and compare the units of measure used in measuring the classroom or playground. Are they able to find a route they take to school? Using figurines to represent the students, could the class find a route to walk to the city hall or library. Would this route be different if going by car? Discuss taking a trip together using this map as a guide and test the route with figurines. Can the class predict how long such a journey would take? Can they devise a system to help them make an accurate prediction?
- 6. Students should walk to a designated area after making this map. This may be useful in visiting the library or the town hall or an historical site.

Discussion

Was this activity helpful to the students? In what ways? If they had to map an area

foreign to them, how might they start? How would they measure large distances? Can the students find their own streets? If so, can they locate where their houses should be? If students were building a new town or city, how would they plan it? What would they include? exclude? What would they do differently?

Topic 3: Coordinate Systems

A coordinate system is just a way of systematically denoting and labeling points in space. Numbered aisles in supermarkets, grids on road maps, and lines of latitude and longitude on the Earth are all coordinate systems which we use every day. Coordinate systems are usually based on two lines, or axes, which are most often perpendicular to one another. In a city, for instance, one building may be "two blocks north and four blocks east", from another, in which case the compass directions of north and east are used as a basis for the grid of the city.

Activity 4-9: Reference Directions on the Earth

This activity requires a sunny day.

On the Earth, we use the directions of the compass for reference: Boston is north and east of New York, San Diego is south of Los Angeles. Canada is north of the United States and Mexico is south. The direction "north" is defined as the direction from any point on the globe towards the North Pole, where the axis of rotation of the Earth sticks out of the surface in the Northern Hemisphere. Similarly, "south" is towards the South Pole. We usually look at maps and globes where North is on the top. Why might this be? Are the two hemisphere's equally populated? Do you think "north is up" seems natural to people in Australia?

If one faces north and extends ones arms straight out to the sides, the left hand points to the west and the right to the east. Looking at a compass rose, one can remember this

because the "W" of west and the "E" of east spell a word - "WE" - if they are properly aligned - "EW" is not a word! The Earth is spinning about its axis such that its surface moves eastward. This is why the Sun and Moon and the stars all rise on the eastern horizon, move westwardly through the sky, and set on the western horizon.

In this activity, we use the midday shadow to find true north, much as in the activity "Sun Shadows" of Chapter 1. If there is not sufficient time (or suitable weather) to use the shadow stick, a compass may be used instead, but keep in mind that the compass points towards magnetic north, not towards the North Pole of the Earth.

Materials: Shadow stick from activity "Sun Shadows" of Chapter 1; large piece of paper; markers; rock or brick.

- 1. Using the shadow stick, determine the direction of north, which will correspond to the shortest (midday) shadow and mark this line on the large piece of paper. Secure the paper from the wind with a rock or brick..
- 2. Draw a line perpendicular to the north-south line. This is the east-west line. Mark each cardinal direction on the paper.
- 3. Have four students stand a few paces from the paper, one at each of the cardinal directions. Have the class name the direction at which each is standing.
- 4. Now have four more students stand at the same distance, but have each one stand between two at cardinal points. These students will be standing at northeast, southeast, southwest and northwest. Draw two diagonals on the paper and mark these directions.
- 5. Now have the class stand near the paper with the compass rose. Look around the school yard for reference points like hills, swingsets, jungle gyms, buildings, etc. Also look for distant landmarks; is there a city nearby? tall buildings on the horizon? or maybe some towering overhead! Determine the directions to these points, with the aid of the compass we've drawn on the paper.

Discussion

Is north always the same direction for everyone? What are the advantages of using such a "global" coordinate system? Are there any disadvantages? Why not just use directions like "three blocks to the left" or "a mile and a half to the right"? Do these directions make assumptions about the traveler's original position and orientation? Are

these directions better for local areas or larger areas? If northeast (NE) is halfway between north and east, where might north by northeast (NNE) be? Where would south by southwest SSW be? If something is northeast of you, what direction are you from it?

Activity 4-10: Mapping on a Grid

This activity will introduce the students to mapping on a grid. While most grids we map by are made of invisible, imaginary lines, the lines of our grid in this activity are clearly visible, the cracks between linoleum floor tiles. Having placed objects on such a grid, the students can then try mapping the area on some graph paper, essentially a scaled down version of the grid. Once the concept of a map on a grid is understood, specific grids like latitude and longitude should make more sense to the students. A great game to play with the students to give them practice with grids is the game of Battleship.

Materials: Linoleum tile floor; masking tape; Post-it pads; markers; objects like blocks, balls, books, boxes to place on the grid; sheet of graph paper for each student.

- 1. Tape off a region of a tiled, linoleum floor (6'x 6' or so) to act as the grid area. If such a floor is not available, grid lines can be laid down with masking tape.
- 2. Label the lines of the grid with Post-it pads. To simplify the coordinate system, label one axis with letters ("A", "B", "C"...) and the other with numbers ("1", "2", "3"...).
- 3. Scatter various objects throughout the grid region. Books, blocks, toys, boxes all make good choices.
- 4. Give each student a sheet of graph paper. Have the students map the area on the graph paper, using the graph paper's grid as a scaled-down version of the grid on the floor. Have them compare maps and discuss results.

Discussion

Did the grid help to map the area? How? What kind of maps use grids? Do grids help on interstate highways maps? Why or why not? Are there any grids on the Earth with

lines we can see like the ones on the floor?

Activity 4-11: Latitude and Longitude on the Earth

The dawn of the Great Age of Discovery, some five hundred years ago, greatly increased the demand for accurate maps and charts. The explorers needed maps which covered areas much more vast than those we have yet constructed; they required maps of nothing less than the entire world which they were exploring. Indeed, much of the work of these early explorers involved making newer, more accurate maps of little- or never-traveled regions.

Even still, it was not until about a century ago that a standard coordinate system to describe locations on the Earth's surface was adopted. An international convention devised the now-familiar system of latitude and longitude and fixed its reference points. As illustrated in the figure, a line of longitude (a meridian) passes through both the North and South Poles. They are labeled according to their angular distance from the prime meridian which passes through Greenwich, England by international agreement. Meridians are labeled between 0° and 180° East or West of the prime meridian. Lines of latitude (often called "parallels") are parallel to the Equator, and are labeled according to angular distance from the Equator- between 0° and 90° North or South. Any point on the surface of the Earth can be uniquely specified by just these two coordinates, latitude and longitude.

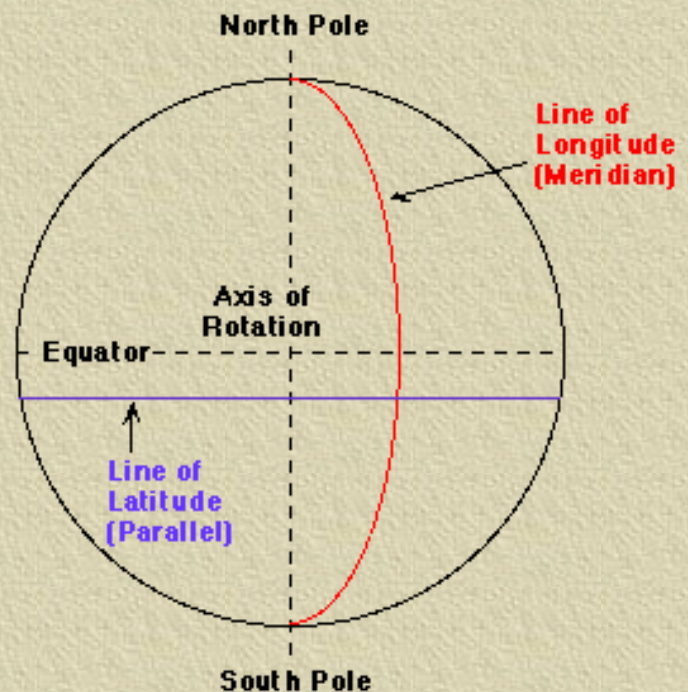

Any point on the surface of the Earth can be uniquely specified by just these two coordinates, latitude and longitude.

Materials: Globe or map of world and local maps with clearly marked latitude and longitude scales; list of cities (on world map) or landmarks (on local map) to find by latitude and longitude coordinates.

- 1. Make a list of several of places with their longitude and latitude for the students to find.

- 2. List a couple of places for each student or each group of students to find. See if they can identify the right place only knowing its longitude and latitude.
- 3. Have each student make a new list of places. The students can trade their lists and try to find the new places too.

Discussion

The lines of latitude and longitude are not straight, since they are on the surface of a sphere. Nevertheless, if one looks at a small enough region, like a city or a town, that region of the Earth is nearly flat, so the lines of longitude and latitude appear straight and seem to form a square grid. Note that close to the Poles, where the meridians converge, the slant of the meridians is quite noticeable, even on small scales, so even if they appear straight, they won't form a square grid.

Topic 4: Celestial Mapping

It is possible to determine your latitude and longitude from observations of the night sky wallpaper. Finding your latitude in the northern hemisphere is the easiest, as it only requires one night's observation of the Pole star. This figure shows a diagram of the Earth with the dashed lines denoting the Earth's equator and the axis of spin. We've placed a small figure of a person on the Earth to show someone observing from a city on the Earth.

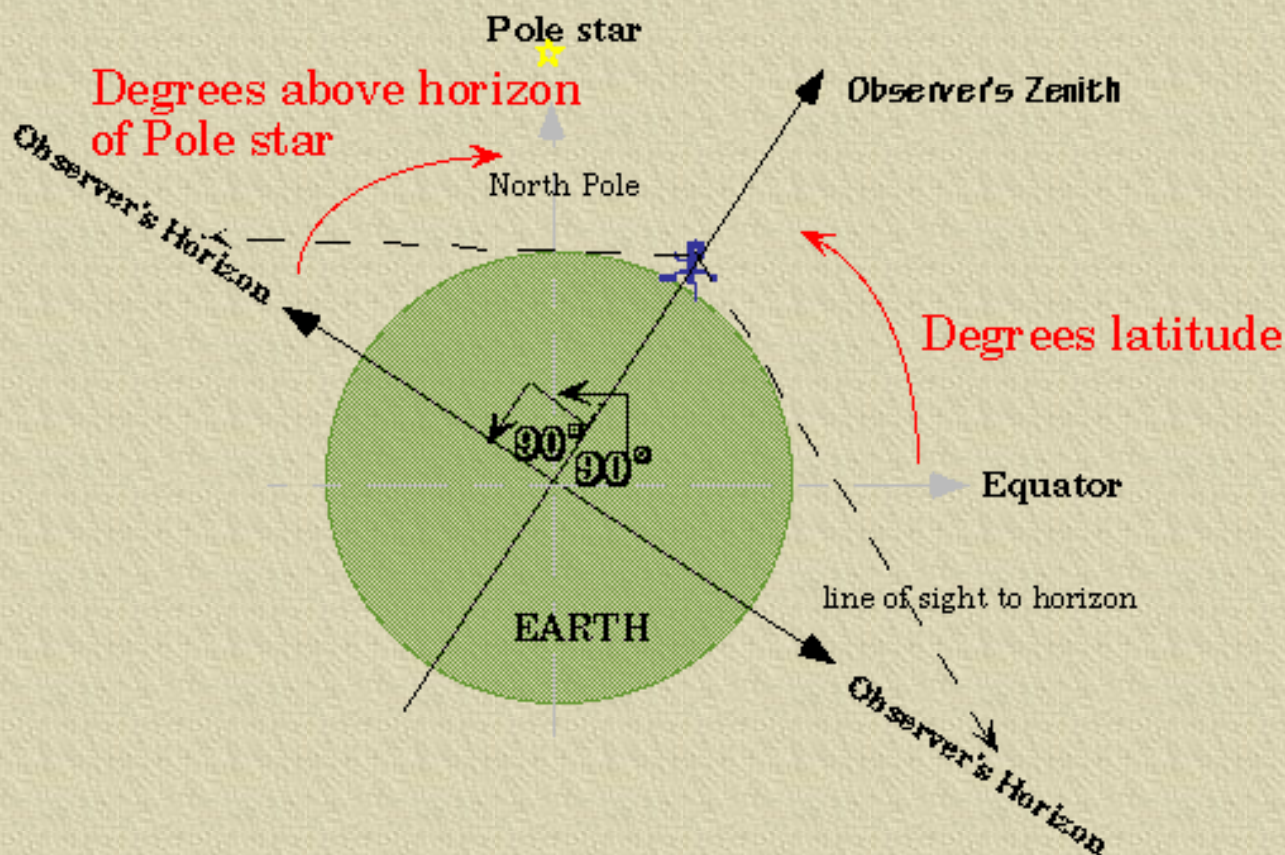

Notice that tracing the line straight up to the zenith point for this observer makes an angle with the equator which is the degrees latitude for this observer (since latitude is defined as the angle above or below the equator). Also notice that the horizon for this observer is marked as the diameter of the Earth perpendicular to the zenith line, or 90° below the zenith point in all directions, defined as such because you can look straight out as well as straight up. Thus, the equator of the earth, if extended up to the sky, is not on the horizon of this observer, but is above it by a number of degrees which are difficult to determine! So, how do we find out how many degrees from the equator, i.e.; degrees latitude, our city is? The figure below shows you that since you know the equator is 90° from the pole by definition and our latitude is 90° from our horizon by definition, that 90° minus our degrees latitude equals 90° minus the height (in degrees) of the Pole star over the horizon OR our degrees latitude equal the degrees of height of the pole star over the horizon! Using the fists method, students can count how many fists and fingers above the horizon they see the Pole Star and that is how many degrees above the equator they are!



Activity 4-12: Calibrating your fist

All you need to know is that 90° is the angle between holding your arm straight out to the side and straight out in front of you. All you need to do is stand still and put your arm out in front of you at eye level, with your hand in a fist. Close one eye. Carefully begin moving your arm stiffly, watching and counting how many fists you can line up side by side until your arm is 90° away from where you started, or straight out to your side. Use things around the yard as guides to help you count those imaginary fists. The figure helps you see what we are describing. Dividing 90° by the number of fists you counted will give you how many degrees your fist covers! (Hint: In case you are not sure of your answer, an average fist covers 10° on the sky. Your value should be close to this.) Similarly, you can try to calibrate your finger! But we will tell you that the human finger held at arm's length will cover 1° on the sky.

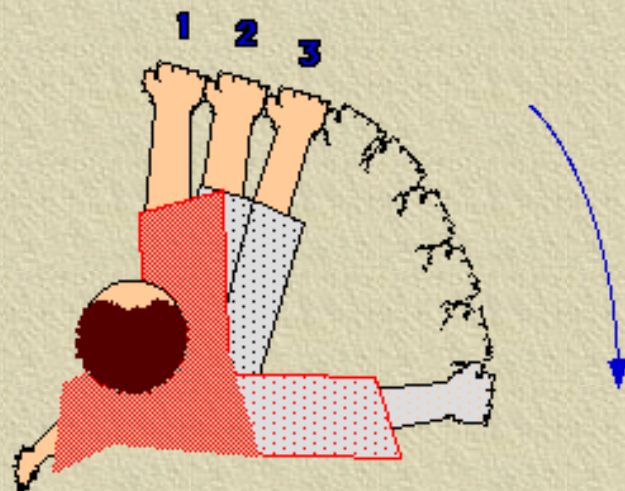

Use things around the yard as guides to help you count those imaginary fists. The figure helps you see what we are describing. Dividing 90° by the number of fists you counted will give you how many degrees your fist covers! (Hint: In case you are not sure of your answer, an average fist covers 10° on the sky. Your value should be close to this.) Similarly, you can try to calibrate your finger! But we will tell you that the human finger held at arm's length will cover 1° on the sky.

Activity 4-13: Measuring your latitude

Materials: Paper and pencil.

- 1. In the evening after the sun has set, students should face north, using their Big Dipper guide from Chapter 1. Students should locate Polaris.
- 2. Students place their fist straight out in front of them with the bottom of the fist resting on the horizon line. They should then count how many fists they can stack up before the top of their fist reaches Polaris.
- 3. Since the students have already calibrated their fists, they know that the number of fists they counted up to Polaris multiplied by how many degrees their fist will cover will give them the number of degrees up to Polaris, or their latitude! Write this down for reference.

Discussion

What kinds of values did the students get for their latitude? Checking with the real latitude of your town, how accurate were these measurements? Could the students find this fists method useful for measuring other heights? Distances between stars on the sky? Sizes of constellations? Diameter of the moon ($1/2^\circ$, or a pencil held at arm's length!)? Perhaps further night observations will allow students to make star atlases describing the constellations in terms of degree sizes on the sky.

Activity 4-14: Mapping the Sky

The visible stars can be used as markers on the sky which can be placed on a map. Such star maps are useful not only to astronomers trying to find a certain star with a telescope but also to children trying to find the Big Dipper. Making a map of the entire sky is similar to making a map of the entire world—both are round and too big to observe all at once, for example. It turns out that celestial maps use a coordinate system very similar to latitude and longitude of their terrestrial counterparts, but on a sky map these coordinates are called "right ascension" and "declination".

These activities can be used either to help students become familiar with constellations before locating them or to help reinforce their observations and help them learn. It may be useful to use these activities to introduce the concept of magnitude of stars. Magnitude is the term used to define the brightness of a particular star. The brighter the star, the lower the magnitude number. The brightest stars have magnitudes from negative numbers up to around 3. The brightest star we can see is Sirius in the constellation Canis Major, which is visible in January and February. It has a magnitude of -1.42. This star is labeled on the Star Map included in Activity 1 of this topic. Conversely, the fainter stars have higher magnitudes. A star whose magnitude is 6 is difficult to see without an optical aid. Also, stars differ in color. They range from the hottest which are blue, then green, white, yellow, orange and red, in descending temperature. Stars appear to twinkle although giving off steady light as our sun does because of the atmosphere of the Earth. Therefore, stars just above the horizon appear to twinkle more than stars up above us because we are viewing them

through more density of the Earth's atmosphere at the horizon.

Discuss constellations and stars already found. What questions do students have? What would they name these patterns or individual stars if they were just discovering them and making order out of them? They may share their ideas about new shapes and configurations from existing star patterns. Some students may want to make up stories to give more meaning to their ideas or this could be a group activity. One person might begin to tell a story about his new creation/constellation and others add to it around a circle. Did the ancients tell stories this way? Without writing down the story, tell it again the next day or week. Does it change? What value would be gained from writing these stories down? What value might be lost?

Activity 4-15: Introduction to Mythology and Storywriting

This may be an appropriate time to introduce the study of Greek mythology since many of the constellations were named by ancient Greeks. After students have found many constellations the stories will capture their attention and have more meaning for them. Students may do research to find out about the Greek gods and goddesses such as Zeus, Athena, Hera, Apollo, Hermes and others. They may enjoy hearing myths as well as reading them. Perhaps they would enjoy hearing a story for each of the zodiac constellations. These are told in a beautifully illustrated book, *The Shining Stars: Greek Legends of the Zodiac*. A companion book to this is *The Way of the Stars: Greek Legends of the Constellations* or Dauliere's *Greek Myths* (for older students). These are listed in the bibliography. Myths often were told because there was a problem that needed to be solved and it was solved within the myth. Students may write their own myths, creating their own gods, goddesses, and part god, part human characters. They too will work through their problems as they learn to write and develop their creativity. Myths often explained natural phenomena. This activity may be enlarged to hearing and discussing the elements of myths from different cultures. The comparisons show universality of themes across time and space. Students will find meaning by reading, listening, and writing these stories without extrapolating a moral or reason.

What is a myth? How does it differ from other stories? Why are there so many stories linking gods, goddesses and part god part human figures? What could ancient people have needed to tell, accomplish by telling stories about the constellations in the sky? If you don't know a story about a constellation could you make one up that has meaning?

Materials: Greek Myths and other myths from a variety of cultures

- 1. Students listen to a number of Greek Myths which relate to the constellations. They read some on their own and do research on the characters in these stories.
- 2. Students may write stories of their own choosing using existing gods, goddesses and heroes or creating new ones. They may imagine that they are in the time frame of the ancients and discuss the effect this has on their writing. What kinds of reasons might they have to write a story? (i.e., explaining natural phenomena such as the occurrence of seasons or happens when people die?) Or do they just want to tell about how they feel about their lives and what is important to them?
- 3. Can they find examples of myths from other cultures which are about the cosmos? Are any of these similar to the ones told by the Greeks? Did any other cultures see the same configurations of constellations? Did they give them similar names? Perhaps students will continue to write stories based on other cultural mythology or they may wish to record stories they make up to go with an imaginary constellation configuration.
- 4. Students may record stories on tape, on the computer, or on paper. Sharing these stories out loud might be done in a circle at various times. If students tell their tales (rather than read them), they will be more expressive.
- 5. Students may wish to tell what this writing experience was like for them. What kinds of stories do people tell now? What about space stories? How has story telling changed? Why has this happened? What kinds of stories will people write in the future?

Activity 4-16: Understanding Star Maps

Materials: Five foot circle of heavy white paper; yarn; pencil; enlarged map of

constellations for current month (available in Sky & Telescope, for instance); yardstick; silver, red, yellow, blue shiny paper; blue tempera paint (small amount of black added), watered down; crayons; colored chalk; white glue.

- 1. Students should find several bright stars on the map and noting colors and sizes.
- 2. They help to make a circle on the heavy paper by determining center and using yarn and chalk to circumscribe a five foot circle using radius of two and one half feet. They mark off eight equal sections, like pie pieces, or other pattern.
- 3. They make the same division into eight parts or more on the star chart and number each section on both circles. Try whenever possible to make the pie pieces along lines which do not cut off constellations.
- 4. Students copy stars (in pencil) and patterns from small to large map section by section. They mark over each penciled star in crayon to resist paint. Try to represent star sizes in scale and colors.
- 5. Students paint entire 5 foot circle with tempera paint over crayoned wax marks and paint in a circular direction (Make sure paint is dark enough to simulate the night sky).
- 6. They represent star sizes, colors and positions by cutting stars of various sizes and colors of shiny papers and glue to maps.
- 7. They then cut direction labels; N, S, E, W out of silver paper and glue them as they are on the star chart, i.e., N on northern horizon, S on southern horizon, etc.
- 8. When dry, hang map on ceiling -- if possible, matching directions with the position of the school. If not possible to hang on ceiling, hang on wall as if facing northern horizon (north at bottom of circle).
- 9. Students use map to locate constellations without lines drawn between them and to identify various stars. They help other students to begin star studies.

Discussion

How did this compare to making an earth map? Did this help students to remember the star groupings and other stars? Could they locate the constellations? North Star? What other ways could they help others to learn what they have learned? How have people used stars for maps? In what other way could this new knowledge help them in their lives? Students may choose a constellation formation, draw it and make a new form

out of it. What name would they give to it? Students may discuss their observations and share theories about stars, their magnitudes, sizes, and configurations.

Activity 4-17: Understanding Distance in Space

The function of this activity is to give the students an understanding that constellations are not flat pictures in the sky, but rather the product of three-dimensional space. The stars are so far away that they appear flat, as if forming a dome above the Earth. Constellations are patterns of stars. For the most part, they are named after characters or animals in mythology. They usually do not look like what they are named for. For instance, Pegasus doesn't resemble a winged horse at all and Cygnus the swan looks more like a cross. Some, such as Canis Major (the large dog), are easier to imagine. The question of whether the stars that make up a constellation are as close to each other as they appear in the sky is a puzzle for students to solve. They should ask themselves what would they see if one star was both next to and far back from another. They should also be wondering why the sky seems flat. The following activity will demonstrate how constellations really are positioned in space, and should give students a better definition of a constellation.

Materials: Large flat field; paper plates.

- 1. Number seven paper plates.
- 2. Hand out the plates to seven students. These plates will serve as stars.
- 3. Demonstrate the positions for holding the plates as the following:
 - LOW: The student sits with the plate at his/her feet.
 - CHEST: The student stands holding the plate at his/her chest.
 - FACE: The student stands holding the plate over his/her face.
 - HIGH: The student stands holding the plate over his/her head.
- 4. Using the diagrams as a guide, have the even numbered students line up about 30 feet from the rest of the class. Have the student with plate no. 2 stand on the far right (from the point of view of the rest of the class) with the plate at his/her chest. Have the student with plate no. 4 stand with the plate at his/her chest about 5 feet to the right of the student with plate no. 2. Have the student with plate no.

- 6 stand with the plate over his/her head 10 feet to the right of the student with plate no. 4.
- 5. Have the odd numbered students stand on a line about 20 feet from the rest of the class. Have the student with plate no. 1 sit in front of the student with plate no. 2 with the plate at his/her feet. Have the student with plate no. 3 do the same thing with respect to the student with plate no. 4. Have the student with plate no. 5 stand with the plate over his/her face about 5 feet to the right of student no. 3. Have the student with plate no. 7 stand with the plate over his/her face to the right of student no. 5.
 - 6. Have the rest of the class look at the seven plates from a distance of about 20-30 feet with one eye shut. Do they see a flat or three-dimensional pattern?
 - 7. Have the odds and evens switch lines so that all the odds are on the back line. Have the rest of the class look at them again. Do they see the same thing?

Discussion

What is a constellation? Are the stars in the sky all the same distance from the Earth? Why do the stars appear to be flat in the sky? What else could be in space besides stars? What do these other objects do in space? Do objects in space move? Are there patterns to the arrangement of the stars? to their movement?

Activity 4-18: Using Star Maps

Note: Finding groups of stars is easier when done with a guide to help. The maps included for this activity are fairly uncomplicated. However, when gazing at the stars, the sky looks much different because of the numerous additional stars visible.

Your students should be able to find the Big Dipper, North Star, and the Little Dipper from the exercises in Chapter 1. Now they will observe more constellations in the night sky.

Materials: Star charts (one for each two month period, included here); flashlight, red cellophane paper to cover lens; rubber bands; binoculars (optional); journals

- 1. Introduce students to the appropriate star map. Discuss using these at home and how to do so effectively. Try them out with students in the classroom using the directions given on the charts. It is important to hold this map so that the direction you are facing is pointing toward you if you are holding it horizontally, or is on the bottom if you are holding it vertically. Have students hold the chart in front of them and raise it above their heads to simulate the actual sky above them. Help them locate Ursa Major (the Big Dipper), Polaris, the Little Dipper, and Cassiopeia. What other constellations (if using November-December chart) do they think they can locate? Have them record observations in journals right after viewing.
- 2. Repeat star map activity with new chart for next two months throughout the year. Are students able to make better predictions to find constellations based on earlier observations? If given one map at a time after using two maps and locating constellations can they predict what the third map will include or not include? Will there be new constellations visible? How about the zodiacal constellations? Can they predict when the next one will appear on the map if given a diagram of the zodiacal procession of constellations?
- 3. Identify particular stars. If observing in September or October look for Vega in Lyra and Deneb in Cygnus. Mizar, which is the star at the bent part of the Big Dipper's handle, has a faint companion star which can be seen by many people without binoculars. If not, binoculars should reveal it.

Discussion

Discuss the observations as a group. Students may have been recording their activities in journals and this should help them to share more easily and accurately. Have the students share their records of the changing positions of the circumpolar stars (or dippers).

How can this pattern be useful to us? What do they notice about the other constellations over a period of time? What do they think is happening? Can they predict what the sky will look like a year from now? Why are some stars brighter than others? Different colors? Throughout this activity students may discuss, compare and predict results of these recordings. How helpful are these predictions to them in their understanding of the patterns of movement they observe in the stars? Are they able to predict the movement of the stars in the next months? Are they able to compare these

observations with those from the seasons and the calendar? How can the pattern of the stars and planets help us keep records?

Activity 4-19: Making a Star Plotter

This activity is appropriate for students in grades 4-6.

Sky mapping is an active way to make an original guide to the sky. Since students are actively engaged in this project, it will help them to view and report findings accurately. A star plotter will help them to chart the positions of the stars just as they see them in the sky. This activity provides a means of illustrating changes in the stars' positions. In this activity, students take records of where the stars have been and when they were there. This activity adds to their education of how the universe moves in orderly patterns.

Students may discuss stargazing experiences. How can they record their experiences and select what they want to remember? How could they use this information? How could they plot the stars and planets to help them learn and remember more about patterns? To explain observations to others?

Materials: Plexiglas or Lucite square about 12" by 12" (1/8-1/4" thick), strip of wood (about 6" by 1" by 1/2" thick) for handle; grease pens; tracing paper; glue for Lucite/wood or screws; drill (1/4" bit)

- 1. Students may make a few star plotters to take turns using. To make: drill two 1/4-inch holes about at the middle of one side of the Plexiglas in about 1/2 inch. Attach the handle with wood screws or appropriate glue.
- 2. Discuss using these plotters. Outside, students must remember to find a place to rest the hand holding plotter to steady it on a tree or post. Then they can point the plotter to a section of the sky with many stars visible. They can make a mark for each object visible making them larger or smaller according to the brightness of the objects. Viewers should record on one corner of the Plexiglas, the direction in which viewing, the angle from the horizon (degrees such as 30°, 45°, 60° - see note in box following Activity 1 in this topic), the hour, and the date.

When inside, tape tracing paper to plotter and trace marks onto it as well as the information on time, etc. Then clean the plotter. Make another map either in another part of the sky or in the sky or in the same area a few hours later.

- 3. Students may make a number of these maps of the same area of the sky at intervals over a period of months in order to record the movement of the stars.
- 4. They may also make maps of constellations with the plotter. Find one of the constellations already discovered with the sky map. Place the star plotter so that this constellation is in the middle of the Plexiglas square. Mark the stars of the constellation with the grease pen as in other plottings. Then add as many of the surrounding stars as possible. Remember to write in the direction, angle, date, and hour you observe. Then trace the dots on the plotter. Connect the stars in the constellation to make a pattern such as the one on the sky map and write the name. This is a more realistic depiction of the constellation as it appears in the sky than on a star map because it includes surrounding stars.

Activity 4-20: The Astrolabe

These activities are more appropriate for grades 4-6.

When students build and use the star plotter in Activity 2, they learn to estimate angles and distances in the sky using their fists. These measurements are not very accurate. To obtain more accurate figures, an instrument may be made to help determine measurements. This is an astrolabe which was invented by the Greeks and disseminated by Islam. This instrument was used to observe and calculate the position of celestial bodies before the invention of the sextant. This activity includes two models, one simple and the other more complicated to measure angles by the stars. It also includes an exercise in geometry using a clock to understand dividing circles into degrees and naming angles. This system of dividing circles into 360° is an ancient one. A circle of 360 equal parts can be divided into



quarter circles (four quadrants) each containing 90 degrees. If using a clock for a model from 12 O'clock to three o'clock is 90 degrees. From 12 O'clock noon to 12 O'clock midnight is 360 degrees.

Polaris or the North Star is a place to start measuring the angle above the horizon. This angle is equal to the latitude at the point where the calculation is figured. Latitude refers to the parallel lines which are numbered from the equator at 0 degrees north to the pole (90 degrees north latitude) and south to the opposite pole (90 degrees south latitude). The latitude of the North Star is 90 degrees at the North Pole and overhead there. At the equator, it would be 0 degrees and visible if possible in a direct horizontal position. If one uses the complex astrolabe it is possible to calculate the position of other celestial bodies by comparing them to the position of Polaris. The complex astrolabe will help students to find constellations and make sky maps with the important stars in their correct positions as viewed from a particular latitude. An inexpensive (around \$3.00) astrolabe is available from:

Science Kit, Inc.
777 East Park Drive
Tonawanda, NY 14150.

Is it helpful to have a system to measure the position of the stars and their height from where we stand? Would it help us to be more accurate in these measurements? How would a measurement made by fists compare numerically with one done by an instrument? How could we check for accuracy of results?

Materials: 8-1/2"x11" sheet of paper or 4' tube; protractor; small weight such as key; thread; tape.

- 1. Discuss measuring and the ancient use of an astrolabe to find the angle of the north star and other sky objects. This is called latitude. The system of measuring degrees can be introduced to students by using the clock as an example.
- 2. Use the tube or roll a paper into a 1/4" tube. Tape the protractor to the length of the tube. Tie a thread around the middle of the flat side of the protractor and attach the weight on the free end of the thread. Practice using this model in the classroom. If 0° represents the equator and 90° the position at the North Pole. Can you predict the latitude where you are?

- 3. At night, locate the North Star. Point the tube directly at it. Look through and find the star. Read the degrees on the protractor as you hold the string at that place. Do this a few times to make recording more accurate.
- 4. How can you check this information for accuracy? Did this instrument change the measurement that you determined or estimated? Can you devise another model to measure the position of objects in space? What other measurements can you make with this model? What differences do you think will occur in measurements of these objects from night to night? In one night, measuring at intervals, what changes do you observe and record?

Building a Complex Astrolabe

Materials: Protractor; thread; weight; 1" thick wood 6"x 3"; (2) 1/2" thick wood 12' x 1/2'; 1/4" bolt and wing nut; nail; heavy cardboard for 12" circle; straw; glue for metal wood; metal fastener.

- 1. Discuss astrolabe; its history and use. Then build one for testing. To build place the two thin strips of wood in a T shape and drill a 1/4 inch hole through the pieces. Fasten them together with the bolt and wing nut leaving it loose enough to move for sighting. Then attach (glue) a protractor to the cross stick centering it on the bolt exactly.
- 2. Attach this to the other piece of wood to form a base. Nail the support stick to the center of one of the long sides. Then cut a 12" circle of heavy cardboard. Divide the circle into quadrants or corners by making two lines at right angles to each other through the center of the circle and mark the end of each of these lines with the directions North, East, South and West. Then divide the spaces between into three equal parts. Each of these represents 30°. Make a hole with a drill through the center of the base and circle. Attach the circle to the base with large metal paper fastener. Draw a line on the center of the base and mark one end North. Tape a drinking straw on top of the narrow strip forming the cross part of the "T". Line the straw up so that it is even with one end of the stick which is the sighting stick. Attach a thread to the bolt and tie the other end to the weight.
- 3. When finished, students can place this outside on a level place with the straw at eye level. After finding Polaris they should sight it through the straw. Since

Polaris is always in the North, the circle can be turned so that the mark for North faces Polaris. Have a student locate another bright star. Leaving the wheel intact, he/she turns the sighting stick to face the star. Then he/she sights the star through the straw. It helps to use a flashlight covered with cellophane to read the direction in which the line on the base is pointing. That line tells you the direction and how many degrees the star is from due north. Then find where the thread crosses the protractor. This indicates the angle above the horizon or latitude. Students may record this information.

Discussion

After many experiences testing this model, students may discuss experiences. In what ways did using this instrument prove helpful? Was it easier to locate constellations with this instrument? Did they record changes in position of stars over a period of hours? Days? What did they discover. How could ancient people learn from this instrument? How could this instrument help us if lost? Is this instrument helpful in making sky maps with the Star plotter?

Related Links

Comments?

[Contents](#) |



[Back to Top](#) |

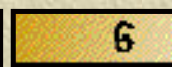

[Home](#)

INTRODUCTION AND INDEX - - 08/07/2004

The following is a short review of spherical trigonometry, celestial navigation, and great circle sailing. The solution of the navigation triangle (section C) can be used for great circle course determination and for determining a location of the observer from astronomical observations. There are many ways to solve spherical triangles, but my interest in this discussion are those methods that can be used on a calculator without the need of special tables.

NAVIGATION TRIGONOMETRY INDEX

A1 [The rhumb line, \(graphical Mercator sailing and middle latitude sailing \)](#)

A2 [Calculated Mercator sailing](#)

B1 [Definitions, the spherical triangle](#)

B2 [The right spherical triangle](#)

B3 [The oblique spherical triangle](#)

C1 The navigation triangle [using the law of cosines](#)

C2 The navigation triangle [using the Ageton method](#)

C3 The navigation triangle [using Napiers analogies](#)

C4 The navigation triangle [using the no-name method](#)

D1 [Approximation methods for great circle sailing](#)

D2 [Graphical great circle sailing](#)

D3 [Calculated great circle sailing](#)

E1 [The Marine sextant](#)

E2 [The Sumner line](#)

E3 [Spherical coordinates](#)

E4 [Sight Reduction](#)

E5 [Sight Reduction Formulas](#)

E6 [The Nautical Almanac](#)

E7 [Sight Reduction Summary](#)

F1 [Selected Navigation Stars](#)

EXTERNAL LINKS

[NAVIGATION AND TRIGONOMETRY - - \(with fewer adds \)](#)

[U. S. NAVAL OBSERVATORY](#)

[Javascript Programs for Navigators](#)

[Java script program for rhumb line sailing](#)

[NAVWORLD](#)

[\[NEXT \]](#) - - - - - navtrig@yahoo.com

The Event Inventor

Make a Quadrant:

- 1) **Print this page on your printer (** [More on my copyright policy HERE](#) **)**
- 2) **Cut out the quadrant scale below**
- 3) **Glue the scale onto particle-board (like the back of a note pad) & cut the board down to the shape of the scale (outer perimeter only)**
- 4) **Glue the FOLDED edge (dashed line) onto the wide edge of your yardstick (or ruler), several centimeters back from the end**
- 5) **Glue one end of a 12 cm. (5 inch) long string to the orange circle & tie a weight to the other end of the string**

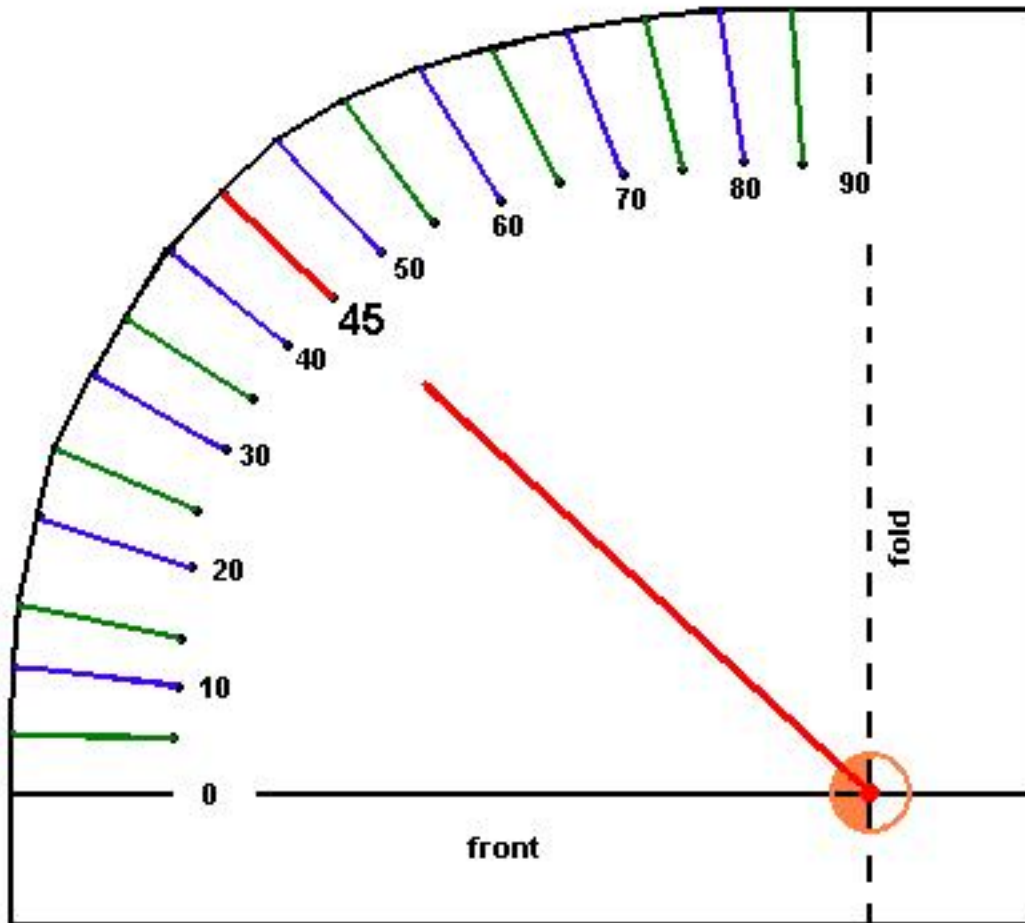

Quadrant scale

[Using a Quadrant](#)

[Back to Pythagoras' Playground to choose a project](#)

[Back to Mars Projects](#)

Instant-Payday-Loans.us

Low Rate Payday Loans

NEED CASH FAST

[Payday Loans Online](http://www.instant-payday-loans.us)

www.instant-payday-loans.us

Provides payday loans up to \$500 in 24 to 48 hours. Loans are deposited into your account. Apply today and get the cash you need, when you need it!

Cash-Advance.biz!

FAST CASH NOW AND WHEN YOU NEED IT!

[Cash Advance.BIZ!](http://www.Cash--Advance.BIZ)

www.Cash--Advance.BIZ -

Don't pay your bills late - avoid late fees by taking a Cash Advance. We make advances up to \$500 with overnight turnaround.

Site Sponsors:

Please visit our sponsors to keep our site up and running!

[Click here](#) if you are interested in sponsoring our site.

The Event Inventor

How to Use a Quadrant;



The quadrant is a device for measuring the altitude of an object.



Altitude is measured by sighting an object along the meterstick, with the zero end touching your cheek bone (under your eye) and the other end pointing directly at the top of the object.



Let the weight swing freely so that the string is "pointing" straight down.



Tilt the stick so that the string touches the quadrant scale, then with your finger and thumb hold the string against the scale, bring the scale end around where you can read it.

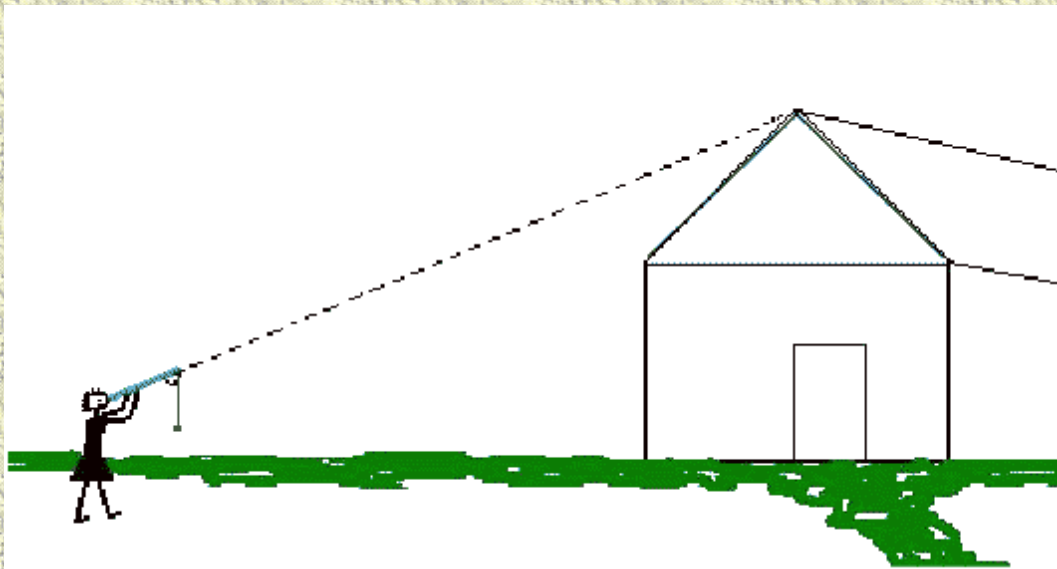

[Forward to Project List](#)

[Back to Pythagoras' Playground](#)

[Return to the Event Inventor's HOME PAGE](#)

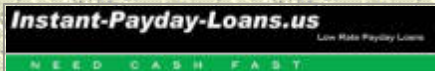

[Payday Loans Online](http://www.instant-payday-loans.us)

**www.instant-payday-loans.us
Provides payday loans up to \$500 in 24 to 48 hours. Loans are deposited into your account. Apply today and get the cash you need, when you need it!**



[Cash Advance.BIZ!](http://www.Cash-Advance.BIZ)

**www.Cash-Advance.BIZ -
Don't pay your bills late - avoid late fees by taking a Cash Advance. We make advances up to \$500 with overnight turnaround.**

Site Sponsors:

Please visit our sponsors to keep our site up and running!

[Click here](#) if you are interested in sponsoring our site.

[Index](#) : [Math](#) : [Geometry](#)

Ptolemy's Ptools

Ever wonder how high a cloud is? You can calculate altitude right from your own backyard and this site will tell you how. It will also show you how to have fun while completing math projects. Learn more about Claudius Ptolemy, a famous Greek mathematician. Check out quadrants and the properties of triangles. Do math projects which measure trees, buildings, cloud altitude, wind speed, and the altitude of a model rocket flight. [Visit Site](#)

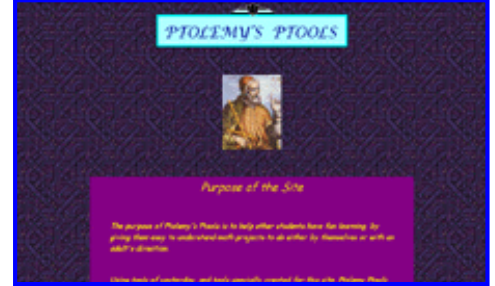

[Visit Site](#)

1998 ThinkQuest Internet Challenge

Languages English

Students Corey
Carl

home schooled
home schooled

Coaches Kye Ewing Palm Beach County Library, West Palm Beach, FL, United States
Shelley Costantino home schooled



Want to build a ThinkQuest site?

The ThinkQuest site above is one of thousands of educational web sites built by students from around the world. [Click here](#) to learn how you can build a ThinkQuest site.

The Event Inventor

Project #3

Measuring Your North Latitude at NIGHT:

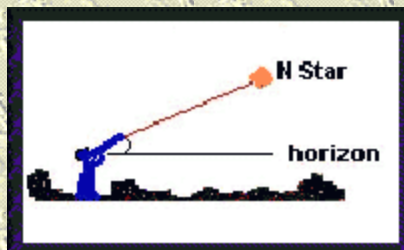

Materials needed:

- 1) Quadrant (from [Make a Quadrant](#) page)

What to do:

 Plan this investigation for a time after dark, in a location where you can see the North Star (if you need help finding the North Star click [HERE](#)).

 Talk about where the North Star would be in the sky if we were at the North Pole (directly overhead at ALL TIMES) and where it would be if we were on the Equator (right on the horizon at ALL TIMES)

 After discussing how to find it, locate the North Star. A bright, directional flashlight can help.

 Note that it is NOT one of the brightest stars in the sky, but that it just happens to be in the RIGHT PLACE in the sky (directly overhead at the North Pole).

 Sight the North Star with your quadrant and note the degree marking its height above the horizon.

 This is your NORTH LATITUDE.

How It Works:

 In this session we take our magic triangles into outer space! We will do this by measuring how high the North Star is above the horizon. We don't even need to be able to see the horizon, because the weighted string will ALWAYS point directly towards the Earth's center. This will always be exactly ninety degrees from a true, level horizon.

💡 The three sides of our **GIANT TRIANGLE** will be:

(a) the horizon line, projected into space

(b) a line from our location to the North Star

and

(c) a line from the North Star to our horizon line, projected into space

💡 The **TRUE** North and South Poles are the places on our planet where **it spins on its axis** (magnetic North, as would be indicated on a compass, is slightly different).

💡 The North Star (Polaris) just happens to be located directly overhead at the North Pole (there is no such conveniently located star in the sky for the South Pole!) This position causes Polaris to appear to **stay in the same place in the sky** (due north) at all times, as the rest of the sky seems to spin around it.

For a view of how to sight Polaris with your QUADRANT

[\(Click HERE to see a DIAGRAM\)](#)

💡 Since the North Star is directly overhead **at the North Pole**, our quadrant reading there would be "**90°**". The North Pole is located at **90° north latitude**. At the **Equator**, our quadrant would show "**0°**" since the North Star would be right on the horizon. The Equator is located at **0° latitude**.

[More Celestial Delights to measure with your quadrant](#)

[Back to the Project List](#)

[Return to the Event Inventor's Home Page](#)



Photo credit: [Russell Kaye](#)



[Payday Loans Online](http://www.instant-payday-loans.us)

www.instant-payday-loans.us

Provides payday loans up to \$500 in 24 to 48 hours. Loans are deposited into your account. Apply today and get the cash you need, when you need it!



[Cash Advance.BIZ!](http://www.Cash-Advance.BIZ)

www.Cash-Advance.BIZ -

Don't pay your bills late - avoid late fees by taking a Cash Advance. We make advances up to \$500 with overnight turnaround.

Site Sponsors:

Please visit our sponsors to keep our site up and running!

[Click here](#) if you are interested in sponsoring our site.

The Event Inventor

[HOME](#) | [TELESCOPES](#) | [SITE MAP](#)

How to Use a Cross Staff:

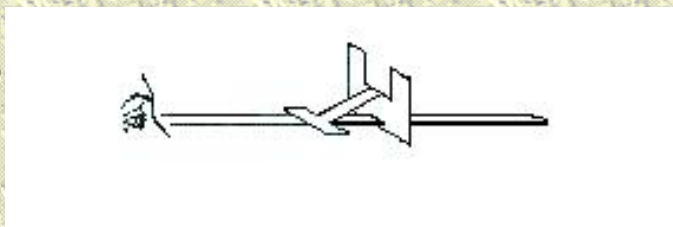

- 1) The cross staff consists of a meterstick and a sliding cross-piece. It is used by sighting an object between the *sighting edges*, with the zero end of the meterstick just below your eye.
- 2) Slide the sighting-piece back or forth until the object(s) being observed fit **EXACTLY** within the sight's edges. ***
- 3) Read the distance from your eye to the slider on the meterstick.

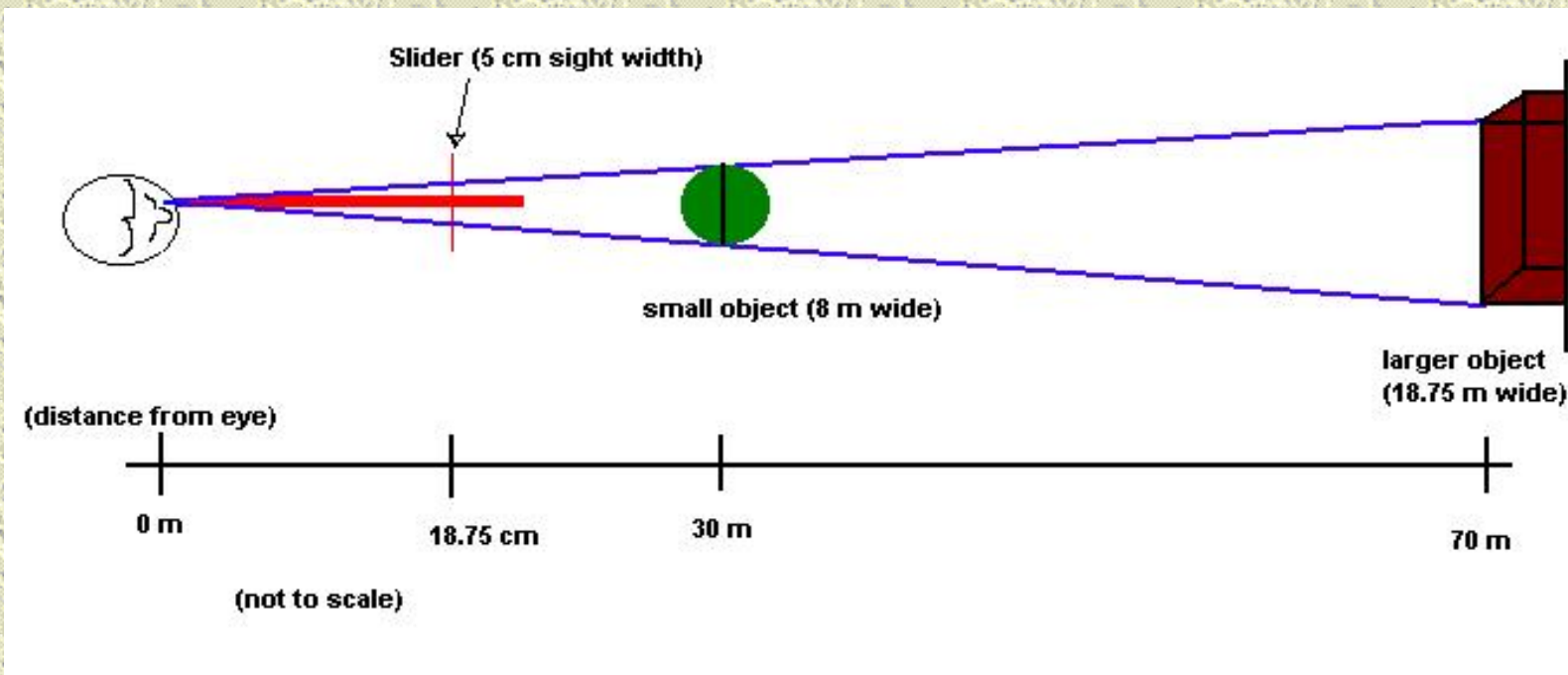

You can consider the triangle from your eye to the sliding-piece's edges as two right triangles put together along the sides of the right angle. Each right triangle's right angle meet at the center of the slider so we will consider 1/2 of the width of the slider to be the base of our right triangles. We can find the tangent ratio (describing the shape of the triangles) by dividing this base

by the distance from your eye to the slider. You could also find the same ratio by dividing one half of the actual width of the object being sighted by your distance from you to it. Using the cross staff to create similar triangles makes it possible to have only one of the triangle's dimensions in order to find the others, since you know its shape.



In our example the slider's sight width is 5 cm., so we will **divide** this in half to get 2.5 cm. as the base of our right triangle. We now **divide** 2.5 cm. by the distance we measure our eye is from the slider (18.5 cm.) The result, 0.135, describes the shape of each of the triangles in the form of a ratio.



If we take this ratio and **multiply** it by the distance to the object we have sighted (30 m) and double the result (remember we are looking at TWO triangles), we find that the tree is about 8 m in diameter.



If we use the same reading for another object that we have sighted (0.135) and know the width of the object (18.75 m), we can **divide** one half of the width by the tangent ratio to find that it is about 70 m away.



Notice that since this is a **ratio** you don't need to worry about the fact that you are measuring centimeters (or inches, or ??) on the cross staff and meters (or feet, or ??) for the object being sighted! The result will always be in whatever units you multiply or divide the ratio by, just remember to keep the units of measure the same!



******* Remember that your cross staff is a simple device and your measurements will be rough approximations. The margin of error is rather high on where exactly the slider should be for the object to EXACTLY fit into view!

[To Regular Cross Staff Project List](#)

[Return to the Event Inventor's HOME PAGE](#)

Site Sponsors:

Please visit our sponsors to keep our site up and running!



[Payday Loans Online](http://www.instant-payday-loans.us)

www.instant-payday-loans.us

Provides payday loans up to \$500 in 24 to 48 hours. Loans are deposited into your account. Apply today and get the cash you need, when you need it!



[Cash Advance.BIZ!](http://www.Cash--Advance.BIZ)

www.Cash--Advance.BIZ -

Don't pay your bills late - avoid late fees by taking a Cash Advance. We make advances up to \$500 with overnight turnaround.

[Click here](#) if you are interested in sponsoring our site.

- ▶ On TV
- ▶ Lesson Plans
- ▶ Teacher's Store
- ▶ Custom Classroom
- ▶ Teaching Tools
- ▶ Curriculum Center
- ▶ Homework Helpers

Favorites

- ▶ Brain Boosters
- ▶ Clip Art Gallery
- ▶ Puzzlemaker
- ▶ Science Fair Central
- ▶ Study Starters

sign up!

For our newsletter and special teacher promotions.

Science

SKY WATCH

HOW TO SEE THE STARS

- HOW TO SEE THE STARS
- SKY EVENT SCHEDULE
- SKY STORIES
- LINKS

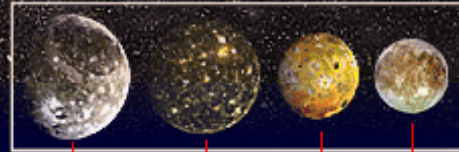

The Planisphere

Download both pages of the planisphere by clicking on each image below and follow the instructions for constructing it. You'll be an astro-wiz in no time!

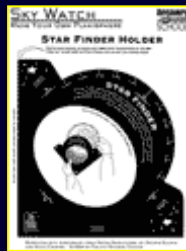

328k 420k

To print the planisphere, you'll need Adobe Acrobat Reader. You can download it for free here:

- | | | | |
|----------------------------|-----------------------------|------------------------------|---------------------------------|
| Windows 95 | Windows 3.1 | Mac (BinHex) | Mac (MacBinary) |
| 4.7 MB | 3.9 MB | 7.4 MB | 5.5 MB |

[Return to - How to See the Stars](#)

[Sky Watch Home](#) · [How to See the Stars](#) · [Sky Events Schedule](#) · [Sky Stories](#) · [Links](#) · [Discussion](#)





1-888-Navigate

Departments

[Online Catalog](#)

[Download Catalog](#)

[Why Celestial Navigation?](#)

[How it Works](#)

[Selecting a Marine Sextant](#)

[About Us](#)

[Related Links](#)

[Contact Us](#)

[Celestaire Home](#)

Navigation Equipment

World's largest selection of marine sextants, navigation computers, compasses, books, videos and software for traditional navigation.

Also included are plotting tools, weather stations, binoculars, radios and GPS receivers to enhance navigation capabilities. Astronomy and historical literature will satisfy the need to delve further.



Copyright © Celestaire, Inc. All Rights Reserved.



Porter Case

Search

More Search Options

Customer Service

Product Index

Ordering Information

Contact Us

Celestaire Home

Shipping Rates

United States

International

Shopping Cart

View Cart

Check Out Now

Top : [Historical Interest](#) : Trilogy of Time

The skills and esthetics of the past were combined with modern technology to produce this kit of three working instruments. Rendered with all the care of early craftsmen, and executed in precision die-cut metallic surfaced cardboard, they effectively mirror the heritage of earlier ages. They are:



- **NOCTURNAL:** A 16th century instrument for converting star-time to sun-time at sea.
- **SUNDIAL:** To tell time from the lengthening shadows cast by the sun
- **PERPETUAL CALENDAR:** A functional instrument which is accurate until the year 2016.

 Trilogy of Time

Item#: 1702 - \$18.00



Lightning Detector

Search
[More Search Options](#)
Customer Service
[Product Index](#)
[Ordering Information](#)
[Contact Us](#)
[Celestaire Home](#)
Shipping Rates
[United States](#)
[International](#)
Shopping Cart
[View Cart](#)
[Check Out Now](#)
Top : [Historical Interest](#) : Planispheric Astrolabe

The Astrolabe is one of the earliest, and at the same time, one of the most sophisticated of all ancient scientific instruments. It served as sextant, star-finder, and time-piece for early astronomers, astrologers, and navigators.

Although designed in the manner of the beautiful Renaissance instruments, this is an original Astrolabe, computed for modern star positions, useful through the year 2046. The Astrolabe comes in kit form. The traditional parts of mother, rete, rule, alidade, and tympan are printed on gold metallic surfaced cardboard, precision die-cut for true accuracy. The parts assemble easily into a working Astrolabe 8 3/8" in diameter. An excellent 21 page booklet concerning its history and construction is included.



Through the high quality materials, and ease of assembly, one not only creates a working instrument, but is afforded a wonderful opportunity to study and relate to historical navigational methods.

 Planispheric Astrolabe

Item#: 1701 - \$24.00

**Wireless Weather****Search**

More Search Options

Customer Service

Product Index

Ordering Information

Contact Us

Celestaire Home

Shipping Rates

United States

International

Shopping Cart

View Cart

Check Out Now

Top : [Historical Interest](#) : Mariner's Astrolabe

This astrolabe was developed by the Portuguese in the 15th Century (much later than the "planispheric" astrolabe). It was designed to be used for both sun and star observations, and as a practical working model is the simplest of all to use. The construction of this astrolabe kit, is precision die-cut in metallic surfaced cardboard. It is easy to assemble and comes with an illustrated brochure outlining its history at sea.



 Mariner's Astrolabe

Item#: 1703 - \$18.00



amazon.com



VIEW CART

WISH LIST

YOUR ACCOUNT

HELP

WELCOME

YOUR STORE

BOOKS

APPAREL & ACCESSORIES

ELECTRONICS

TOYS & GAMES

MUSIC

CELL PHONES & SERVICE

SEE MORE STORES

Search

Browse Subjects

Bestsellers

Magazines

Corporate Accounts

e-books & docs

New & Used Textbooks

Used Books

Search:

Browse:

You clicked on this item...



Longitude

by Dava Sobel

Average Customer Review: ★★★★★
Usually ships in 24 hours



Eligible for **FREE Super Saver Shipping** on orders over \$25. [See details.](#)

Price: \$9.56
You Save: \$2.39 (20%)

140 used & new from \$3.95

Need it today? Available for in-store pickup from \$10.76 . Price may vary based on availability. To check availability in your area, enter your ZIP Code

Or [buy used](#): \$3.95

Amazon.com

The thorniest scientific problem of the eighteenth century was how to determine longitude. Many thousands of lives had been lost at sea over the centuries due to the inability to determine an east-west position. This is the engrossing story of the clockmaker, John "Longitude" Harrison, who solved... [Read more](#)

You may also be interested in these items...

[Customers also shopped for](#)

Show items from:

▶ **All Products**

[Books](#) (20)

[DVD](#) (15)

[Electronics](#) (1)

[Kitchen & Housewares](#) (1)

[Magazine Subscriptions](#) (2)

[Music](#) (7)

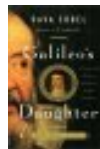

Galileo's Daughter

by Dava Sobel

[More like this](#)



The Riddle of the Compass

by Amir D. Aczel

[More like this](#)



The Map That Changed the World

by Simon Winchester

[More like this](#)



The Illustrated Longitude

by Dava Sobel, William J. H. Andrewes

[More like this](#)



The Professor and the Madman

by Simon Winchester

[More like this](#)



Longitude

DVD

[More like this](#)

	 <p><u>Brunelleschi's Dome</u> by Ross King More like this</p>	 <p><u>The Measure of All Things</u> by Ken Alder More like this</p>	 <p><u>The Meaning of Everything</u> by Simon Winchester More like this</p>
--	--	---	---

[More results](#) ▶

<p>New at Amazon.com Visit our new Seasonal Tableware Store and save up to 40% on Lenox, Spode, and more.</p>	<p>\$25 Off Tools & Hardware Take \$25 off when you spend \$199 or more on Tools & Hardware products offered by Amazon.com. Here's how (restrictions apply).</p> <p>\$25 Offer</p>	<p>New at Amazon.com</p>  <p>Find more than 600,000 china, crystal, and silver products in the Replacements, Ltd. Store.</p> <p>REPLACEMENTS LTD.</p>
--	--	--

<p>Where's My Stuff?</p> <ul style="list-style-type: none"> Track your recent orders. View or change your orders in Your Account. 	<p>Shipping & Returns</p> <ul style="list-style-type: none"> See our shipping rates & policies. Return an item (here's our Returns Policy). 	<p>Need Help?</p> <ul style="list-style-type: none"> Forgot your password? Click here. Redeem or buy a gift certificate. Visit our Help department.
--	--	---

Search **for**

Your Recent History
[Learn More](#)

<p>Recently Viewed Products</p> <ul style="list-style-type: none">  Celestial Navigation for Yachtsmen by Mary Blewitt  Practical Celestial Navigation by Susan Peterson Howell  Celestial Navigation Simplified VHS ~ William F. Buckley Jr.  Latitude Hooks and Azimuth Rings by Dennis Fisher  The Stars by H. A. Rey 	<p>Customers who bought items in your Recent History also bought:</p> <div style="display: flex; justify-content: space-around;"> <div data-bbox="836 1302 1185 1533">  <p> The Sextant Handbook by Bruce Bauer</p> </div> <div data-bbox="1201 1302 1567 1564">  <p> Celestial Navigation in a Nutshell by Hewitt Schlereth</p> </div> </div>
--	--

▶ [Visit the Page You Made](#)

Turn your past books purchases into \$\$\$
[Learn more](#) about selling at Amazon.com today!

[Top of Page](#)

[Books Search](#) | [Browse Subjects](#) | [Bestsellers](#) | [Magazines](#) | [Corporate Accounts](#)

[e-Books & Docs](#) | [Bargain Books](#) | [Used Books](#)

[Amazon.com Home](#) | [Directory of All Stores](#)

Our International Sites: [Canada](#) | [United Kingdom](#) | [Germany](#) | [Japan](#) | [France](#)

[Contact Us](#) | [Help](#) | [Shopping Cart](#) | [Your Account](#) | [Sell Items](#) | [1-Click Settings](#)

[Investor Relations](#) | [Press Releases](#) | [Join Our Staff](#)

[Conditions of Use](#) | [Privacy Notice](#) © 1996-2004, Amazon.com, Inc. or its affiliates

You are here: [NMM Home](#) / [What's on](#) / [Exhibitions](#) / Royal Observatory

[Go back one level](#)

[National Maritime Museum](#)

[Royal Observatory](#)

[Queen's House](#)

John Harrison and the Longitude problem

The Harrison timekeepers are on permanent display in Flamsteed House at the Royal Observatory, Greenwich. [Take our interactive virtual tour of Flamsteed House.](#)

The Longitude problem

Whereas, in order to the finding out of the longitude of places for perfecting navigation and astronomy, we have resolved to build a small observatory within Our Park at Greenwich...

Charles II



The Royal Observatory, Greenwich

[Repro ID PU8920](#)© NMM London For every 15° that one travels eastward, the local time moves one hour ahead.

Similarly, travelling West, the local time moves back one hour for every 15° of longitude.

Therefore, if we know the local times at two points on Earth, we can use the difference between them to calculate how far apart those places are in longitude, east or west.

This idea was very important to sailors and navigators in the 17th century. They could measure the local time, wherever they were, by observing the Sun, but navigation required that they also know the time at some reference point, e.g. Greenwich, in order to calculate their longitude. Although accurate pendulum clocks existed in the 17th century, the motions of a ship and changes in humidity and temperature would prevent such a clock from keeping accurate time at sea.

King Charles II founded the Royal Observatory in 1675 to solve the problem of finding longitude at sea. If an accurate catalogue of the positions of the stars could be made, and the position of the Moon then measured

Page index

1. The Longitude problem
2. [John Harrison \(1693-1776\)](#)
3. [H1 \(1730-1735\)](#)
4. [H2 & H3 \(1737-1759\)](#)
5. [H4 \(1755-1759\)](#)
6. [Winning the Longitude Prize](#)
7. [Rupert Gould](#)

Related websites

- [The Harrison initiative](#)
- [The Worshipful Company of Clockmakers](#)
- [English attack on the Longitude problem](#)
- [How a pendulum clock works](#)
- [Celestial navigation](#)
- [British Horological Institute](#)
- [A walk through time](#)
- [Collections online](#)

Useful tools

- [Single page](#)
- [PDF version](#)
- [Find similar](#)
- [Email this document](#)
- [Print this page](#)

accurately relative to the stars, the Moon's motion could be used as a natural clock to calculate Greenwich Time. Sailors at sea could measure the Moon's position relative to bright stars and use tables of the Moon's position, compiled at the Royal Observatory, to calculate the time at Greenwich. This means of finding Longitude was known as the 'Lunar Distance Method'.

In 1714, the British Government offered, by Act of Parliament, £20,000 for a solution which could provide longitude to within half-a-degree (2 minutes of time). The methods would be tested on a ship, sailing

...over the ocean, from Great Britain to any such Port in the West Indies as those Commissioners Choose... without losing their Longitude beyond the limits before mentioned

and should prove to be

...tried and found Practicable and Useful at Sea.

A body known as the Board of Longitude was set up to administer and judge the longitude prize. They received more than a few weird and wonderful suggestions. Like squaring the circle or inventing a perpetual motion machine, the phrase 'finding the longitude' became a sort of catchphrase for the pursuits of fools and lunatics. Many people believed that the problem simply could not be solved.

[1](#) | [2](#) | [3](#) | [4](#) | [5](#) | [6](#) | [7](#) | [Next >](#)

See also:

- [Time telling](#)

© NMM London



NOVA Teachers

SEARCH NOVA TEACHERS

[Back to Teachers Home](#)

Lost at Sea -- The Search for Longitude

Program Overview

NOVA chronicles the seventeenth-century journey to determine longitude.

- In 1714, following a maritime disaster, British Parliament offers £20,000 for the first reliable method of determining longitude on a ship at sea.
- It is known that longitude can be found by comparing a ship's local time to the time at the port of origin. The challenge is finding a clock -- a chronometer -- that can keep time at sea, where temperature changes, humidity, gravity and a ship's movement affect accuracy.
- Early attempts are based on the assumption that astronomy can solve the problem.
- Self-taught clockmaker John Harrison believes the answer lies in large mechanical clocks. Through careful observation and experimentation, he invents many adaptations to improve clock accuracy. After decades of work, he realizes pocket watches are a better choice and redirects his efforts to pursue this smaller technology.
- In 1764, Harrison's watch proves accurate in helping determine the longitude on a six-week voyage to Barbados.

TEACHER'S GUIDE

Lost at Sea -- The Search for Longitude



Original broadcast:
October 6, 1998

[BUY THE VIDEO](#)[PROGRAM OVERVIEW](#)[VIEWING IDEAS](#)[CLASSROOM ACTIVITY](#)[IDEAS FROM TEACHERS](#)[RELATED NOVA RESOURCES](#)

[NOVA Home](#) | [Teachers Home](#) | [TV Schedule](#) | [E-Mail Bulletin](#) | [Help](#) | [Shop](#)

[NOVA](#)

[Teacher's Guide by Title](#) | [by Subject](#) | [Transcripts](#) | [Credits](#) | [Site Map](#)

[PBS TeacherSource](#)

© | Updated December 2003



"Lost at Sea - The Search For Longitude"

PBS Airdate: October 6, 1998

[Go to the companion Web site](#)

NARRATOR: During the following program, look for NOVA's Web markers, which lead you to more information at our Web site.

Tonight on NOVA: In the days when sailors had to find their speed in knots and dead reckoning could be fatal...

VOICE OF ___: It was very easy for the pirates to catch the cargo ships.

NARRATOR: An unknown genius discovered the key to navigating the open seas—time. Now, based on the best selling novel by Dava Sobel, "Lost at Sea - The Search For Longitude."

Major funding for NOVA is provided by the Park Foundation, dedicated to education and quality television.

And by Iomega, makers of personal storage solutions for your computer, so you can create more, share more, save more and do more of whatever it is you do. Iomega, because it's your stuff.

NARRATOR: This program is funded in part by Northwestern Mutual Life, which has been protecting families and businesses for generations. Have you heard from the quite company? Northwestern Mutual Life.

And by the Corporation for Public Broadcasting and viewers like you.

[*THE EYE OF THE WIND—LONELY SHIP AT SEA*]

VOICE OF FISHERMAN: Oh, God, thy sea is so great, and my boat is so small.

NARRATOR: To be lost at sea meant wandering an empty ocean. A lonely ship, far from shore and never finding safe harbor. These perils were the stuff of legend since ships first sailed beyond the sight of land. But until just over 200 years ago, there was no sure way of knowing the position on the high seas. Navigation because the greatest scientific challenge of the age of sail.

[*PARIS OBSERVATORY—EMBOSSSED STONEWORK OF INSTRUMENTS WS GREENWICH EXTERIOR AND OCTAGON ROOM*]

Any nation which found the method of accurate navigation could rule the

economy of the world. In Paris and at Greenwich, observatories were built, to chart the sky in an effort to learn if the moon and stars could help guide a ship at sea. It was, of course, assumed that the answer would come from these royal institutions or great universities.

[VILLAGE OF BARROW/COTTAGE WINDOWS—SOUND OF LATHE/RECREATION—HARRISON WORKING]

NARRATOR: But far away, in a remote English village called "Barrow-on-Humbar," a carpenter named John Harrison was teaching himself clock making. He had no formal education, but his clocks were highly original. Harrison learned his craft while observing village life around him.

[CU CLOCK PENDULUM/BELLS SWINGING]

JOHN HARRISON: I, from being a bell ringer since a boy, had saw the bell swinging in an enormous arc, 250 degrees or more.

[CLOSE SHOT—THE TENOR BELL/CU CHILD RINGING THE BELL—HANDS ON ROPES]

VOICE OF JOHN HARRISON: And when I went to plot out the pendulum of my first timekeeper, I knew that proper point in the swing where to best apply the force. I speak from strictly due experience, which is the best proof of usefulness, notwithstanding what University men may write or do.

[BELLS]

NARRATOR: Neither a university man nor an astronomer, having never been to sea, what role could John Harrison have in solving the greatest technical enigma of his time?

[THE CREW LETTING OUT THE LOG WITH WILL ANDREWES]

NARRATOR: Consider the problems of the sailors and navigators of the 1700s. On the training vessel Eye of the Wind, the passengers and crew are about to experience the challenges of being at sea on board a tall ship and finding their way across vast reaches of open ocean. Will Andrewes, Curator of Harvard University's Collection of Historical Scientific Instruments, has joined the crew in this exploration of ancient navigation. They're trying out a replica of a typical log and line of the early 1700s.

WILL ANDREWES VO: It was a triangle of wood which was called the log, and onto that was tied the line. It was a knotted line, knots tied at intervals of about 48 feet 3 inches. The navigator would throw the line over the side of the ship. And the first 50 feet of line would be clear, but as soon as the marker on the line passed through the navigator's fingers, the navigator would shout "Turn" and count the number of knots flowing through his fingers in the time it took a 28-second sand glass to flow through. This would give the speed of the ship in knots.

NARRATOR: Measuring the speed with knots was one of the techniques of

dead reckoning. It was a crude method, and it didn't allow for currents or cross winds, which could easily push a ship off course. But it was then the only way to estimate distance traveled at sea.

[ANIMATION 1—DEFINE LATITUDE AND LONGITUDE]

NARRATOR: For centuries map makers have used grid lines to indicate points on the surface of the earth. This grid system evolved into lines of latitude and longitude. Latitude is represented by parallel horizontal lines circling the earth, with the Equator as the line of zero degrees latitude.

Longitude is depicted by the vertical lines, or meridians, running from Pole to Pole.

Any point on earth can be defined by a degree of latitude and a degree of longitude. But 300 years ago only the latitude was measurable, and that with great difficulty.

[*EYE OF THE WIND*—WILL USES CROSS STAFF]

NARRATOR: Navigators knew that the height of the noon-day sun varies. On the equator, it would be high in the sky, but in the far north, the sun remains low on the horizon.

By measuring the angle between the sun and the horizon, latitude could be calculated—if the navigator could survive the hazards lurking in his own instruments.

[*EYE OF THE WIND*—WILL USING CROSS STAFF]

WILL ANDREWES VO: As a cross staff, this was actually designed for use on land, and it was adapted for use at sea. One of its problems is that one has the staff held against one's eye and, with the ship moving up and down you not only get blinded by the sun, but you also get badly bruised on the eye bone. so it's not the easiest of instruments to use.

NARRATOR: But without any means of figuring longitude - their east-west position—latitude was all navigators could hope to use.

DAVA SOBEL: The safest way to go was to get to the right latitude in waters that had favorable currents and winds and then just go. Except that everybody else knew that you'd be going that way. So it was very easy for the warring nations to lie in wait for each other or for the pirates to catch the cargo ships. And it was an untenable situation, but what else could you do? If you struck out on a new route, you were just as doomed.

[GRAY SEAS - PAN TO ROCKS]

NARRATOR: On a damp October day in 1707 a fleet of British warships was returning home from battle with the French. They were just a day's sail from England.

[ANTIQUÉ MAP ILLUSTRATES THE ROUTE]

NARRATOR: Although they had no way of determining their exact position, they believed they were safely clear of the treacherous Scilly Islands off the English coast.

[SEAS AND ROCKS]

NARRATOR: But as the ships sailed on, a crash was heard on the lower decks of the flagship.

[PAINTING OF THE DISASTER]

NARRATOR: They had run aground, and the hull had been severed below the water line. One by one, four ships hit the rocks. And one by one, they sank. In a matter of minutes, thousands of men drowned and an important part of England's fleet was lost.

[MEMORIAL STONE/WS AISLE OF CHURCH, CHURCH WINDOWS]

NARRATOR: The wreck of Admiral Shovell's fleet was a national tragedy. There were days of mourning, official inquiries. If England was to be master of the seas, how could such a disaster have happened in her home waters?

An official of the Royal Navy, Samuel Pepys, had expressed the nation's alarm:

[PORTRAIT - PEPYS]

VOICE OF SAMUEL PEPYS: It is most plain from the confusion all these people are to be that it is by God's almighty providence and the wideness of the sea that there are not a great many more misfortunes in navigation than there are.

[LONGITUDE ACT DOCUMENTS]

NARRATOR: The unfortunate situation had been exposed, and an outcry finally forced some action. In 1714 Parliament offered a reward to anyone who could solve the key problem of navigation—how to find longitude at sea.

The prize was big enough to capture the attention of the nation: £20,000, equivalent to millions today.

Proving voyages to the West Indies would be required to test the method, and a distinguished board would pass judgement.

DAVA SOBEL: Sir Isaac Newton, one of the—the Prime Commissioner, showing just how important the problem was and high-powered the board was. There were—the top scientists were on it, the top admirals, members of parliament. This was a blue ribbon panel, if ever there was one.

NARRATOR: But if Newton and the Board expected that the huge prize would quickly produce an answer, they were frustrated by the rush of loony, half-backed pamphlets which flooded the book stalls of London.

[CRANK PROPOSALS]

VOICE OF CRANK #1: The Only Method for Discovered Longitude, Humbly Proposed for the Consideration of the Publick.

VOICE OF CRANK #2: Longitude Explained, or Taking the Time on Tiptoe

[HOGARTH ETCHING: LUNATICS]

NARRATOR: William Hogarth's etching shows a pack of Longitude Lunatics searching for solutions within their asylum walls. Finding longitude, in the public's mind, had become the work of madmen.

[RECREATION—CLOSE SHOTS OF HARRISON—HANGS PENDULUM]

NARRATOR: For John Harrison, at the age of twenty, clock making had become a passion. He was obsessed with accuracy and, by about 1720, he too had become intrigued with the problem of longitude at sea.

[CU HARRISON'S JOURNAL]

NARRATOR: Although he was mostly unschooled, Harrison kept a detailed journal. Some of his writings have survived, and his own words reveal how quickly he grasped the essence of the longitude problem—its connection to time.

[HARRISON NEAR WALL BESIDE HUMBER]

JOHN HARRISON VO: I suppose that the difference of longitude betwixt a ship at sea and the port it sailed from might be as nearly known as its latitude if the ship had along with it a machine or watch that would exactly point out what time it was at the home port.

But it is said by all the—the motion of the ship has rendered all such machines as have been tried so irregular as to be of no service to the seaman in the matter of the longitude.

[ANIMATION OF GLOBE WITH LONGITUDE MERIDIANS]

NARRATOR: In theory, a clock should work. The earth turns a full 360 degrees in 24 hours, or 15 degrees each hour.

[ANIMATION 2 - FINDING LONGITUDE MEANS FINDING TIME]

NARRATOR: To know the longitude, one must know the time in two places

at once. If a sailor knew when it was noon at the home port—Greenwich England, for example—and then had to wait one our until it was high noon on board his ship, he would know that the ship was 15 degrees west of Greenwich. If the sailor had to wait two hours for the sun to reach its high point, he was 30 degrees west. The challenge was knowing the time at the home port while sitting hundreds or thousands of miles away.

[HARRISON BESIDE HUMBER]

JOHN HARRISON VO: I judged that my intended sea clock will indeed require a regularity, a performance, as has not been seen before. A nicety of two or three seconds a month.

[BROCKLESBY PARK STABLES]

NARRATOR: Harrison understood that an exceptionally accurate timekeeper which would work at sea could solve the problem. But few clocks had reached the level of accuracy, even on land. Here, above the stables of the great English country house at Brocklesby Park, one of Harrison's first machines still keeps time. Each Thursday morning the estate's carpenter winds the movement.

[HARRY WINDS THE MECHANISM]

HARRY VO: I've been coming here to wind this Harrison clock for 30 years or thereabouts. My predecessor, he was winding it for 50 years. As far as I know, it's been very little trouble since 1722, when Harrison installed it.

[CLOCK MECHANISM, CU GRASSHOPPER, THE PENDULUM AND WOODEN BEARINGS]

NARRATOR: It was a wooden clock, like all of Harrison's early timekeepers. Its sturdy frame disguises its extraordinary accuracy and innovative features.

Harrison refined the mechanisms found in other clocks of the period. Tick by tick, the gear wheels rotate as their driving weights descend.

On each side of the toothed wheel, the unique grasshopper escapement transfers its impulses at the start of each swing.

All of this as the pendulum provides a constant measure of time.

HARRY VO: Being a joiner myself, I appreciate the quality of the timber that he used. The wood has a natural oil in it, so the clock is virtually maintenance-free. The materials that Harrison used are still in perfect condition, considering the time—1722—he didn't do a bad job, really.

[RECREATION—HARRISON TURNING SPINDLE ON LATHER/PULL FOCUS TO CU HARRISON]

NARRATOR: As a carpenter, Harrison knew the properties of wood. And this led him to a new way of reducing friction, which all clock makers knew was the enemy of accuracy.

ANDREW KING VO: Harrison had to deal with the problems of friction. The oils of the early 18th century were terrible. They'd dry out, they'd gum up very, very quickly. The main wood Harrison used to reduce friction was a tropical wood called "lignum-vitae." It's found in the Caribbean and South America. And it has natural resins in it, which never, never dry. For the top of the clock and the last wheel of the wheel tray, instead of using a plain bush, Harrison pivots the wheel on little—these little rollers made of lignum-vitae, which reduce friction enormously. It was the first time this had ever been done.

[*EYE OF THE WIND—STORMY SEAS*]

NARRATOR: But could a clock based on these methods work at sea?

WILL ANDREWES VO: There are enormous problems in trying to make a precision piece of clockwork perform accurately at sea. There's the humidity. There are changes in atmospheric pressure. There's different gravity and different latitudes. There are enormous variations in temperature, from the cold North Sea to the blazing suns of the Caribbean. These affect the materials out of which the timekeeper is made. And then, of course, the most obvious of all is the rocking of the ship, the tremendous shocks that the ship receives when it moves from one wave to the other. All these things made it virtually impossible for a timekeeper to keep time at sea, or so they thought in the 18th century.

NARRATOR: But some way of keeping the time at sea had to be found.

[*GRAPHIC—WHISTON-DITTON PAMPHLET*]

NARRATOR: Desperate problems invite desperate solutions. One fantastic scheme was presented by Professors William Whiston and Humphry Ditton.

[*ANIMATION OF WHISTON-DITTON METHOD*]

VOICE OF WILLIAM WHISTON: All that would be needed is a straight row of 20 or 30 warships somehow permanently anchored across the Atlantic. At midnight each night, the ships would fire off large sky rockets, which could be seen or heard for 100 miles around. With the explosions, mariners will always know when it is midnight in Greenwich and will be able to determine their longitude by comparing Greenwich time to the local time on board their ship.

NARRATOR: If sky rockets were impractical, the sky itself might provide time signals if one knew where to look.

[*GRAPHICS—PORTRAIT OF GALILEO AND CHARTS*]

NARRATOR: Using a primitive telescope, in 1610 the great astronomer

Galileo discovered four moons circling the planet Jupiter.

[ANIMATION—TABLE AND ANIMATION OF MOONS OF JUPITER]

NARRATOR: He carefully charted their motions. The four moons would become a celestial timekeeper when tables were eventually drawn, to show their positions at seven o'clock each night, precise to within a few minutes.

[PARIS—FOUNTAIN AND OBSERVATORY]

NARRATOR: By the 1660s the Italian disciples of Galileo were close to perfecting his method of telling time with Jupiter's moons. News of this breakthrough reached the Paris Observatory, which was soon to become the home of the greatest Italian astronomer since Galileo—Giovanni Domenico Cassini.

[CAFE D'OBSERVATOIRE—UP TO STREET SIGN: RUE

CASSINI/DRAWING—LOUIS XIV WITH CASSINI/DR. SUZANNE DEBARBAT WALKS UP STAIRS]

NARRATOR: Using the moons of Jupiter to find longitude promised to revolutionize map making. And, hoping to provide better maps for his busy map collectors, King Louis XIV set his new Italian astronomer to work.

[DR. SUZANNE DEBARBAT WALKS THROUGH OBSERVATORY]

NARRATOR: Cassini would start by measuring the distance from the Paris meridian to the coasts.

[CASSINI'S MAP OF FRANCE]

SUZANNE DEBARBAT VO AND ON-CAM SYNC: In 1671, an operation of measuring the position of the French coast began. VO: Cassini was observing the eclipses along the meridian line and astronomers were doing the same observations along the coast of France. The measurements of—by the astronomers made a big difference in the coast, and the areas of France diminished of about 20 percent.

NARRATOR: When the stunned Louis XIV first saw the new, highly accurate map of his diminished kingdom, he is said to have exclaimed "I have just lost more territory to my astronomers than to all my enemies."

[STATUE OF CASSINI/LES HYPOTHESES ET LES TABLES DES SATELLITES DE JUPITER]

NARRATOR: Cassini's method relied on the best telescopes of the day. It has a high level of accuracy—perhaps a bit too high for the King. But could the same system be used at sea?

SUZANNE DEBARBAT VO: It's impossible to do the same at sea because of the motion of the boat.

[*EYE OF THE WIND AT NIGHT*]

SUZANNE DEBARBAT VO: To observe the eclipse of the satellites with good accuracy, you need to be stable, which is not the case on a boat.

[RECREATION—TELESCOPES AT SEA]

NARRATOR: With Jupiter unable to be used as a clock at sea, there seemed to be two alternatives. Either find a different astronomical clock, or build a mechanical one. And Newton and the Board of Longitude were skeptical of mechanical clocks.

[PORTRAIT—NEWTON]

VOICE OF ISAAC NEWTON: I have told the world oftener than once that longitude is not to be found by watchmakers but by the ablest astronomers. I am unwilling to meddle with any other method than the right one.

DAVA SOBEL VO: Newton really prejudiced the Board by saying in no uncertain terms that no clock would ever succeed in finding the longitude.

[HARRISON LOOKING OUT AT SKY]

NARRATOR: Working in isolation, John Harrison never heard Newton's doubts; and the labor to perfect his clocks went on.

He now needed to check the accuracy of his timekeepers to within seconds a day, but the village sundial wasn't good enough.

[RECREATION—HARRISON CHECKS STARS]

ANDREW KING VO: Harrison quite simply looked at the stars. But there were no time standards whatsoever, but it's quite possible to get—to—to take star readings. As the world rotates, the fixed stars come into your vision every day at a certain time. But they arrive three minutes 54 seconds earlier every day. And Harrison managed to take sightings from his house.

[HARRISON USES HIS WORKSHOP WINDOW TO VIEW THE SKY AS IT PASSES HIS NEIGHBOR'S CHIMNEY/HARRISON LINES UP CHIMNEY/CHIMNEY - SUPER STARS—MIX TO SECOND HAND ON CLOCK/WS HARRISON]

JOHN HARRISON: I fashioned a true way of setting my clocks by the apparent motion of the fixed stars, with a large sort of an instrument of about 25-yard radius, composed of the west side of my neighbor's chimney and the east side of my own window frames. By which the rays of a star are taken from my sight almost in an instant. And counting the seconds of the clock, beginning a little before the star vanish. And so I observe at what second it vanisheth.

[WS HARRISON VIEWING STARS]

NARRATOR: John Harrison's living room had become a genuine scientific laboratory.

[RECREATIONS—WORKSHOP/HARRISON WORKING WITH IRON AND BRASS WIRES]

DAVA SOBEL: If this was a period of scientific revolution, Harrison was a real revolutionary character, a lone genius, totally uncaring about what everyone else was doing. He invented everything he needed.

NARRATOR: Of the many factors which could degrade a clock's performance, none was worse than the effect slight changes in temperature had on the speed of the movement.

VOICE OF JOHN HARRISON: The pendulum must always retain the same length. But there's no metal whatever whereof to make a pendulum that is not continually altering its length according to the degrees of heat and cold.

DAVA SOBEL: Harrison's achievement represents a fundamental issue in science—whether science proceeds by theory or by the hands-on work of an experimenter.

[RECREATION—WIRES AND PENDULUM]

NARRATOR: Searching for a pendulum which would not be affected by temperature, Harrison noticed that heat caused brass and iron wires to expand at different rates. Making use of this observation, he combined wires of the two metals to compensate for expansion, producing and perfecting his gridiron pendulum.

ANDREW KING VO: He developed testing methods. These clocks were incredibly accurate. He tested one clock against another, which is totally unheard of in his own day.

[RECREATION—TEMPERATURE EXPERIMENTS/PAN FROM PENDULUM TO HARRISON WORKING IN COLD HALLWAY]

JOHN HARRISON VO: Two clocks, placed one in one room and the other in another, in very cold and frosty weather, I made one room very warm with a great fire, whilst the other is very cold.

NARRATOR: He would succeed only when there was absolutely no time difference between the two clocks, whether hot or cold. It was brilliant science requiring astonishing feats of observation.

VOICE OF JOHN HARRISON: I could stand in the doorway, and I could hear the beats of both pendulums, by which means I could have the difference of both clocks to the 20th part of a second—less—and thus I proved the operation of my pendulum wires and adjust the same...

[CLOSE SHOT PENDULUM]

ANDREW KING: The very thought that, uh, you could produce a precision timekeeper of a wooden clock seems quite, quite out, out of order, as well. And yet, Harrison claimed that these clocks were accurate to a, uh, accurate to within a second a month. This is something that wasn't even thought of until the 1880's. Harrison was 150 years ahead of his time. He was incredible.

[RECREATION: HARRISON PACKING UP PAPERS]

NARRATOR: By 1730, John Harrison had collected enough information on the effects of temperature, friction, and gravity to convince himself that he could really build a sea clock accurate and reliable enough to win the Longitude Prize.

[GREENWICH - EXTERIOR/PORTRAITS: HALLEY AND GRAHAM]

NARRATOR: For the first time in his life, he ventured beyond the vicinity of Barrow, traveling to London to present his proposal to the esteemed Astronomer Royal, Dr. Edmond Halley, predictor of the comet which bears his name. Halley arranged an introduction to London's most famous clock maker, George Graham.

[RECREATION: HARRISON WALKING BESIDE HUMBER/HARRISON RETURNS HOME]

NARRATOR: After a stay of several weeks Harrison returned to his village. His journals describe his London adventures, and give a glimpse of the country carpenter meeting England's most distinguished scientists. His plain-spoken memoirs suggest that he was less than impressed by the work of the celebrated George Graham.

[RECREATION: HARRISON DESCRIBES HIS LONDON VISIT]

JOHN HARRISON: Dr. Halley, advised me to go to Mr. Graham, advice which went very hard with me, for I thought it a step very improper to be taken. But he told me Mr. Graham was a very honest man and would do me no harm as by pirating anything from me.

Mr. Graham began, as I thought, very roughly with me, which occasioned me to become rough too. But, we uh, we got the ice broke and we reasoned the cases more than once. And our reasoning, or as it were sometimes debating, held from about ten o'clock in the forenoon till eight o'clock at night. I had along with me some drawings of the principal parts of my pendulum clock, and also my intended timekeeper for the longitude.

While Mr. Graham proved indeed a fine gentleman, if truth be told, I was taken aback by the poor little feeble motions of his pendulums...the small force they had like creatures sick and inactive. But I, um, commented not on he folly in his watches.

JONATHAN BETTS: When Harrison knocked on the door, here was a, um, a joiner's son from Lincolnshire with no formal education, and here he was producing plans for a clock with wooden wheels of all things. You can imagine how Graham must have, uh, reacted to that. But, there's no doubt that as soon as Harrison got out his drawings of his gridiron pendulum and showed Geor, three, George Graham that, he would have been incredibly impressed because we know that George Graham has been trying to design just such a temperature compensated pendulum himself some years before and had failed. So, this must have been the turning point for Graham. This was no time waster.

[RECREATION—TRACK PAST BRASS CLOCK UNDER CONSTRUCTION/MIX TO WIDE SHOT]

NARRATOR: Harrison's meeting with George Graham was indeed a turning point. With Graham's support development money began to flow, allowing Harrison to build his first longitude timekeeper, the sea clock known today simply as H-1.

[H-1—WOODEN GEARS BRASS BALANCES AND SPRINGS]

NARRATOR: One by one, Harrison attacked the problems of adapting his clocks to go to sea. Working in brass for the first time, he continued to use wheels of oak to engage rollers of *ignum vitae*. To overcome the motion of the ship Harrison replaced his long pendulum with two rocking balance arms with springs to maintain their oscillations.

JONATHAN BETTS: And in this way, he got round all of these problems and produced, arguably, one of the most remarkable marine timekeepers of all time.

[H-1 AT GREENWICH—FRONT VIEW, THEN TILT UP MECHANISM/MIX TO EYE OF THE WIND/HEAVY GRAY SEAS]

NARRATOR: In 1736, Harrison accompanied his first sea clock on a preliminary testing voyage to Lisbon on board *The Centurian*. The stormy five-week journey was to be the only ocean trip of John Harrison's life.

WILL ANDREWS: VO: On the return voyage from Lisbon there were storms and the ship lost its position. The crew kept a rough idea of where the ship was by dead reckoning. Harrison was maintaining its location as best he could by the timekeeper, and when land was sighted, the South Coast of England was sighted, there was a dispute as to what point of land it was. They knew they were not far from the Scilly Isles where Sir Cloudseley Shovels' fleet had been wrecked. Sync: As land got closer the crew realized that Harrison was right. His timekeeper was proved to be a practical invention.

[RECREATION: HARRISON EXAMINES BALANCE ARMS]

JOHN HARRISON: My clock has been on a voyage, a very rough one. Upon my meeting the Captain, he said to me that the difficulty of measuring time with the motion of the sea gave him concern, and he felt I'd attempted

impossibilities. He later wrote a report and said, Mr. Harrison was sea sick throughout, but the motion of the sea was not in the least detrimental to his sea clock keeping true time.

JONATHAN BETTS: We believe it performed very well, although we don't know the exact performance of H-1, but we have reason to believe it was well within five to ten seconds a day, which would not have won he is not the great Longitude Prize, but it was far better than most people had expected and it gave Harrison great cause to believe that he was on the right track.

[GREENWICH: TRACK FROM H-1 TO H-2]

NARRATOR: Without even asking for additional tests Harrison put H-1 aside and took on the job of producing what he hoped would be an improved model, H-2.

JONATHAN BETTS VO: In working on H-2, Harrison must have employed other workmen and he would only have given one individual a small amount of work to do so that no single person could claim to have made any of it and, therefore, be entitled to any of the prize money. We know Harrison was paranoid about the idea of other people taking his ideas.

NARRATOR: After two years of painstaking work Harrison noticed a fatal flaw. When subjected to a specific extreme movement the accuracy of his bar balances was corrupted.

JONATHAN BETTS: Being a very ruthless man with himself, he simply then set the machine aside and moved straight on to his third machine. There was no way he could improve it, so he simply left it.

[TRACK AROUND ABANDONED H-2]

NARRATOR: Harrison's development of his large sea clocks was bogging down. Years passed as his quest for perfection led up many blind alleys. For a man obsessed with time, his own time meant nothing to him.

And while Harrison stumbled, his rivals, the astronomers, were attempting to win the Longitude Prize by telling time using our own moon. Their method was beginning to show promise.

[GRAPHIC: ASTRONOMERS TAKING READINGS]

NARRATOR: Both moon and stars move across the night sky. Astronomers knew that the position of the moon against the stars was unique for every minute of every day. They had the makings of a true celestial clock if someone could work it all out in advance. Enter the forceful champion of this lunar method, the Very Reverend Nevil Maskelyne.

[PORTRAIT: MASKELYNE]

DEREK HOWSE: Nevil Maskelyne, uh, he was a bit pompous. The fact he

was a reverend, of course, doesn't come into it because all scientific people who wanted to get on in science had to take holy orders at that time, so we can forget that one. But, he was pompous, a bit of a prig, I think, probably.

[PORTRAIT: MASKELYNE (another)]

NARRATOR: If John Harrison was the perpetual outsider, Nevil Maskelyne was the perfect insider. As a well bred, ambitious young astronomer from Cambridge, Maskelyne set out to make a name for himself within the scientific establishment.

DAVA SOBEL: I find Maskelyne a particularly unpleasant character. He did a great deal for navigation, but here is somebody who kept track of every dime...

DEREK HOWSE: ...every penny that he spent for about forty years is, in fact, recorded...

DAVA SOBEL: ...but he took that same maniacle meticulousness and applied it to his astronomical work, and that's where he did a great good service, and perhaps he couldn't have done it without that sort of attention to detail.

[GREENWICH: TELESCOPES AND QUADRANTS (USE WITH OLD PRINT)]

NARRATOR: Laboring at Greenwich, Maskelyne observed the motion of the moon against the background of stars. Eventually, he could predict its position for every minute of every day. Using these predictions, Maskelyne produced a set of astronomical tables.

[ANIMATION - LUNAR DISTANCE]

NARRATOR: Unlike Jupiter, no powerful telescopes were needed. From his ship, a navigator would measure the angle between the moon and certain stars. Then, in theory, he could use Maskelyne's tables to find the time at Greenwich, if he had clear weather, precise instruments, and after hours of calculations.

[EYE OF THE WIND AT NIGHT]

NARRATOR: But from a rolling deck just keeping site of the moon was a difficult chore, even without the lengthy computations.

SUZANNE DEBARBAT: The method of lunar distances was based on very long calculations. I've read that it needs about four hours of calculation after one observation to obtain the longitude. Four hours of calculations, and during these four hours the boat ...went during that time. If you use the clock like it was proposed by Harrison it's enough, more or less, to read the clock.

[DR. DEBARBAT WALKING AROUND CORNER OF LITTLE OBSERVATORY]

NARRATOR: But the Board of Longitude still would not accept that the clock was the answer, and it controlled the funds Harrison desperately needed to work on his difficult H-3.

DEREK HOWSE: I think that it was a question that these new fangled gadgets, uh, should we rely on them. Uh, the method was perfectly satisfactory. If you had a clock or a watch which could keep absolute time over all these times, then, of course, that's fine. But would it?

[RECREATION: JOHN HARRISON LOOKING AT HIS CLOCK]

JOHN HARRISON: They said, a clock can be but a clock, and the performance of mine, though nearly to truth itself, must be altogether a deception.

I say, for the love of money, these professors or priests have preferred their cumbersome lunar method over what may be had with ease, for certainly Parson Maskelyne would never concern himself in such a matter if money were not bottom.

...and yet, these university men must be my masters, knowing nothing at all of the matter, farther than that one wheel turns another; my mere clock being not only repugnant to their learning, but also the loss of a booty to them.

[GREENWICH—TRACK TO H-2 25:32:44/H-3—VARIOUS SHOTS 25:47:07]

NARRATOR: Harrison continued to work. In his H-3 he replaced his swinging bar balance with large balance wheels. Almost as an aside he invented the caged roller bearing, a friction reducing device still widely used today. And yet, his new clock continued to prove troublesome. Perhaps Harrison's large timekeepers had reached a dead end.

[INTERCUT WITH HARRISON WATCHMAKING WORKBENCH]

JONATHAN BETTS: SYNC: It was while he was struggling with H-3 that he made the breakthrough that he was desperately looking for. VO: He knew for many years that it would be extremely useful to him if he could improve these dreadful things called pocket watches, and in 1753, he instructed a watch maker, called John Jefferys, to make a watch for him to his own design, to Harrison's own design.

[INTERCUT WITH HARRISON WATCHMAKING WORKBENCH/CLOSE SHOTS OF THE WATCHES HE WAS EXAMINING/PLANS OF H-4—HE PLACES THE COMPONENTS AGAINST HIS DRAWINGS]

JONATHAN BETTS: VO: The going of the Jefferys watch far exceeded Harrison's wildest dreams and he began to realize maybe he had been barking up the wrong tree for all these years and he should have been working on watch development, not these large machines.

[CLOCKS, WATCHES, PLANS WORKBENCH/HANDS HOLDING SMALL

COMPONENTS]

NARRATOR: This was an extraordinary change of direction. Now Harrison was prepared to reject 25 years of his own work and move ahead on an almost untried technology, struggling to make smaller what he had always assumed should be made larger.

JONATHAN BETTS: The result, of course, was H-4 which was finished in 1759 and which positively proved to Harrison that he had solved the problem.

[EYE OF THE WIND—RECREATION PROVING VOYAGE/BURNT OUT SHOTS, MOVEMENTS FROM SEA UP TO FIGURES]

NARRATOR: The Board of Longitude ordered H-4 to be tested on a proving voyage from Portsmouth, England to the island of Barbados.

[SEA AND REPEAT THROUGH THE SEQUENCE/CABIN INTERIOR H-4 BOX]

NARRATOR: Locked in its new protective box the precious watch had been carefully set to the correct time at Portsmouth using the sighting of the sun at noon.

[CREWMAN]

NARRATOR: For 46 days The Tartar sailed southwest across the Atlantic.

[RECREATION: WA (OVER SHOULDER) TAKES SEXTANT READING OF LOW SUN/THE CLOCK IN ITS CASE IS ASSIDUOUSLY WATCHED OVER/CLOCK IS BROUGHT FOR INSPECTION/ BCU KEYS/WAITING OFFICERS/ON DECK/ROUGH SEAS - PAN TO DECK OFFICER/HELMSMAN CHECKING COMPASS]

NARRATOR: The ship passed from the chill of the English Channel to the tropical Caribbean—a temperature difference of 50 degrees.

[INTERIOR CABIN]

Except for winding, the watch remained untouched in its box throughout the voyage. John Harrison was now 71 years old, and the burden of this test had passed to his son, William.

[SUN/SAILING OFF LAND]

NARRATOR: After a month and a half at sea, on the morning of May 13, 1764, the Tartar dropped anchor off Bridgetown, Barbados.

[MIX TO LONG BOAR HEADING FOR SHORE]

NARRATOR: The watch was rowed ashore to be examined.

[BARBADOS—SEA SHORE 09: 43: 41/WALLS OF OLD FORT, WAREHOUSES/BARBADOS—PAN TO PARLIAMENT BUILDING/ GRAPHIC: PANORAMIC PAINTING OF BRIDGETOWN HARBOR, CIRCA 1760.]

NARRATOR: To know if H-4 has passed the test the exact longitude of Bridgetown itself had to be determined to a new level of accuracy. this was clearly work for an astronomer.

[PORTRAIT: MASKELYNE/RECREATION: LOCAL WORKMEN CONSTRUCT AN OBSERVATION TENT/BRASS TELESCOPE IS SET UP IN TENT/ MIX TO/DUSK—TILT DOWN TO TENT/SHADOW OF ASTRONOMER'S PROFILE SEEN THROUGH TENT]

NARRATOR: In a great irony Nevil Maskelyne, Harrison's chief rival, had been sent to Barbados months earlier to make careful land-based, moons of Jupiter observations for the purpose of determining the correct longitude.

Maskelyne was quick to accept the assignment, but he had his own agenda. He planned to use the trip as a trial of his lunar method.

Working away in the tropical night, Maskelyne toiled with his instruments. It was reported that several of Barbados prominent citizens heard him boast that his lunar distance system was superior to any clock and might itself win the \$20,000 (English pound) Longitude Prize when he returned to England.

Besides the glory, there was a great deal of money at stake.

WILL ANDREWES IN CHURCHYARD: The misunderstanding begins when Harrison arrives in Barbados in May 1764.

[BARBADOS COAST AT SUNSET?]

WILL ANDREWS VO: the principal purpose of this voyage was to test his father's timekeeper, which his father had taken a lifetime to build.]

NARRATOR: The testing of the clock in Maskelyne's hands was bound to be thorough, but would it also be fair and objective?

WILL ANDREWES IN CHURCHYARD: SYNC: William and his father, John Harrison, knew that Nevil Maskelyne was very interested in the lunar distance method. He was a good astronomer and they didn't complain before the voyage that he had been chosen as the principal person to make the observations on the island to determine the success of his timekeeper. However, when William Harrison arrived in May 1764,

[MASKELYNE'S TENT, HIS TELESCOPE AND PORTRAIT]

VO: he found out that Maskelyne had been talking a great deal about the lunar distance method. William Harrison created quite a scene. He didn't want Nevil Maskelyne to do any observations. This was an enormous slur on Maskelyne's character and Maskelyne resented it bitterly.

NARRATOR: Maskelyne's boasting had created an appearance of conflict-of-interest. A century-long quest for longitude had come down to a contest between the work of two stubborn men on the beaches of a remote tropical island.

[RECREATIONS: OPENING BOX BCU KEYS IN LOCK/BOX IS OPENED AND CUSHIONS PULLED BACK TO REVEAL H-4/CLOSE ON MINUTE HAND OF H-4/MIX TO MECHANISM]

NARRATOR: At the moment of noon, just as the sun reached its highest point over Bridgetown, William Harrison prepared to unlock H-4's case. The clock had not been reset for forty-six days. At that same moment the watch indicated that it was 3:55 PM back in Portsmouth. At fifteen degrees of longitude per hour, the clock placed the Harbor at Barbados just under sixty degrees west of Portsmouth, only a few miles from what we now know to be its actual position.

[ZOOM INTO WATCH]

ANDREW KING: When you imagine that the most accurate watch that you could buy in the 18th century was accurate within only a minute a day, Harrison produced this watch. It went to the West Indies and back, and after a six week voyage this thing was accurate to within about 30 seconds of time. This is just unheard of.

WILL ANDREWES: At the meeting of the Board of Longitude in January 1765, along with the official news of the success of John Harrison's fourth marine timekeeper came the devastating news to Harrison that Nevil Maskelyne was to be appointed Astronomer Royal.

[RECREATION - BOARD OF LONGITUDE (DESK)]

NARRATOR: With Maskelyne now able to influence the Board, Harrison's hope that H-4's performance would quickly gain him the prize began to fade.

To the members of the Board, the clock's very accuracy was cause for suspicion.

ANDREW KING: SYNC: They were either government appointees or from the Royal Navy, or professors from universities,....

[H-4 WORKINGS]

ANDREW KING VO: ...they just didn't understand mechanics; I think they were frightened of it. It was a system of solving the longitude problem that they couldn't really cope with. They could understand an astronomical problem, but the SYNC: the very idea of a mechanical timekeeper that was so good that it was just too good to be true. They couldn't accept it.

[RECREATION - BOARD OF LONGITUDE (DESK)]

JONATHAN BETTS: VO: As far as the members of the Board of Longitude were concerned there was no particular vendetta against Harrison. In some ways, these people were far too boring for that kind of exercise, but at this stage they really believed that their summation was best and that these tick-tock clocks simply could not be believed.

ANDREW KING: Just imagine today that the government introduced award of, say, a million pounds for someone who could produce a 2-liter motor car that could do a thousand miles to the gallon. We'd all laugh at the idea. But supposing someone from the remote regions of the country comes down to London with a car and says to the government, "This car will do a thousand miles to the gallon. Where's my million pounds"? And so they say, oh come on, what's under the bonnet? "I want my million pounds then I'll tell you". And so the arguments start. He's not going to tell you what's under the bonnet because he knows perfectly well somebody's going to pinch the idea. And Harrison was in exactly the same position.

[RECREATION—BRIEF CLOSE SHOTS OF BOXES, CART WHEELS ON COBBLES]

NARRATOR: On the instructions of Nevil Maskelyne, Harrison's timekeepers were carted away for further tests. This left Harrison deeply discouraged.

JOHN HARRISON: Justice, as touching my reward or encouragement, has been scandalously frustrated.

Mr. Graham said to several gentlemen that I deserved the 20,000 pounds, yet the Board has turned me into a slave.

Well, they took great care about my watch, for they also locked it up for some time in a closet at the Admiralty because it had performed to voyages so well. And so they would keep it as a piece of treasure for fear nobody else would ever be able to make another. It's a fair sign indeed that they did not understand it. Nay, my timekeeper is beyond the reach of both the Latitude and the Longitude of these villainous priests of Cambridge and Oxford.

The trouble which these lunar men of occasion be.

NARRATOR: Finally, in 1772, Harrison's son wrote a letter to George III, pleading on behalf of his father. The two Harrisons were soon granted an audience with the King of England.

The Monarch must have been moved by the mens' story because he whispered to an aide these two people have been cruelly wronged. And then, turning to face father and son, he cried out for all to hear, "By God, Harrison, I shall see you righted."

DAVA SOBEL: I think it was very difficult for Harrison, and I think after all those years of willing struggle to have finally succeeded and met many unfair demands to push the project through extra trials and repeat replica performances, to get the money grudgingly but never the full trumpet

fanfare, yes you did it, well done, must have left him feeling terribly bitter and disappointed, because it was always the principal of the thing with him.

NARRATOR: And so, forty-three years after a young John Harrison first travelled to London, a reluctant Parliament at the insistence of the King, awarded him the full 20,000 pounds.

JOHN HARRISON: I can boldly say that no timekeeper, whether in the pendulum way or that of the balance can never be able to go any truer or better than mine. And now, at sea, longitude may be had with great certainty and exactness. I've indeed had a long deal of labor, but I thank God I've got it free.

NARRATOR: In 1995, the first truly world-wide navigation system was realized. GPS, the Global Positioning System now provides navigators their latitude and longitude within a few feet anywhere on Earth. As 24 satellites orbit ten thousand miles overhead, their atomic clocks are monitored for almost perfect accuracy.

[TRANSMITTING DOWN 29, ZERO HOURS, 35 MINUTES EXACTLY/THE RESULTS ARE 29]

NARRATOR: Today, just as it was three hundred years ago the secret of knowing where you are is knowing what time it is. ■

Columbus and Celestial Navigation



Although Columbus was primarily a [dead reckoning](#) navigator, he did experiment with celestial navigation techniques from time to time. However, these experiments were usually unsuccessful -- and in some cases, actually fraudulent.

1. Introduction

In celestial navigation, the navigator observes celestial bodies (Sun, Moon and stars) to measure his latitude. (In Columbus's day, it was usually impossible to measure your longitude.) Even in ancient times, it was fairly easy to find your latitude by looking at the Sun and stars, as long as you weren't too concerned about accuracy. Each star has a celestial latitude, or declination. If you know the declination of a star that is directly overhead, that's the same as your latitude on earth. Even if a star isn't directly overhead, if you can measure the angle between the star and the overhead point (called the zenith), you can still determine your latitude that way -- provided you measure the star at the time of night that it is highest in the sky.

But in the Mediterranean Sea, it's not very useful to find your latitude, because your latitude is roughly the same wherever you are. In those confined waters, dead reckoning was the easiest way to navigate. It was not until the fifteenth century, when Portuguese mariners began to make long voyages north and south along the coast of Africa, that celestial determination of latitude began to be useful for southern European sailors.

Columbus was from Genoa, one of the leading Mediterranean ports, and he must have learned his dead reckoning navigation from Genoese pilots. But he had spent time in Portugal, and was aware of all the new ideas in navigation, including celestial navigation. So on his first voyage he made at least five separate attempts to measure his latitude using celestial methods. Not one of these attempts was

successful, in part because of bad luck, and in part because of Columbus's own ignorance of celestial techniques and tools.

2. The tools.

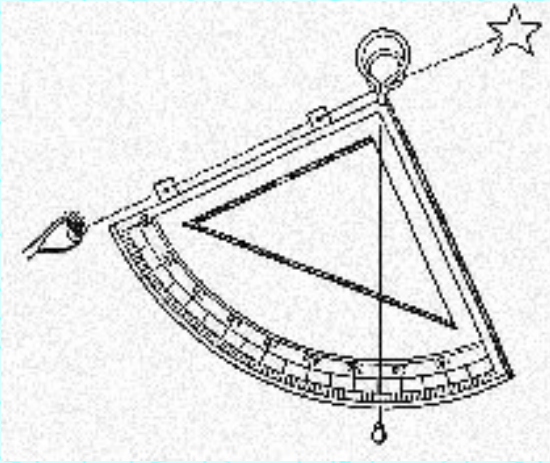

The most important tool used by Columbus in his celestial attempts was the quadrant. This was a metal plate in the shape of a quarter-circle. From the center of the circle hung a weight on a string, that crossed the opposite edge of the circle (see figure 1). The navigator would sight the North Star along one edge, and the point that the string crossed the edge would show the star's altitude, or angle above the horizon. (In the case of the North

Star, this is always pretty close to your latitude). Many examples of quadrants survive in maritime museums, and often have several scales along the edge. For example, in addition to the angle, you might also read the tangent of the angle from the quadrant. The tangent scale is useful if the quadrant is to be used for architectural purposes.

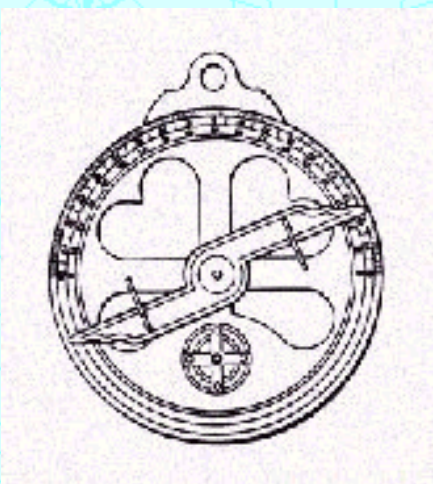

Columbus also carried an astrolabe on the first voyage, which is somewhat similar to the quadrant. The astrolabe was a complete circle of metal, and had a moving arm (or alidate) that the navigator would sight along to find the star's altitude. Columbus tried to use the astrolabe once, but was stymied by bad weather, and he never used it again. Both the quadrant and astrolabe are dependent upon gravity to work, so they can measure only vertical angles. The quadrant was accurate to about

a degree or so, and the astrolabe was a little less accurate.

Time aboard ship was measured by a sandglass (or in Spanish, *ampoletta*). It was

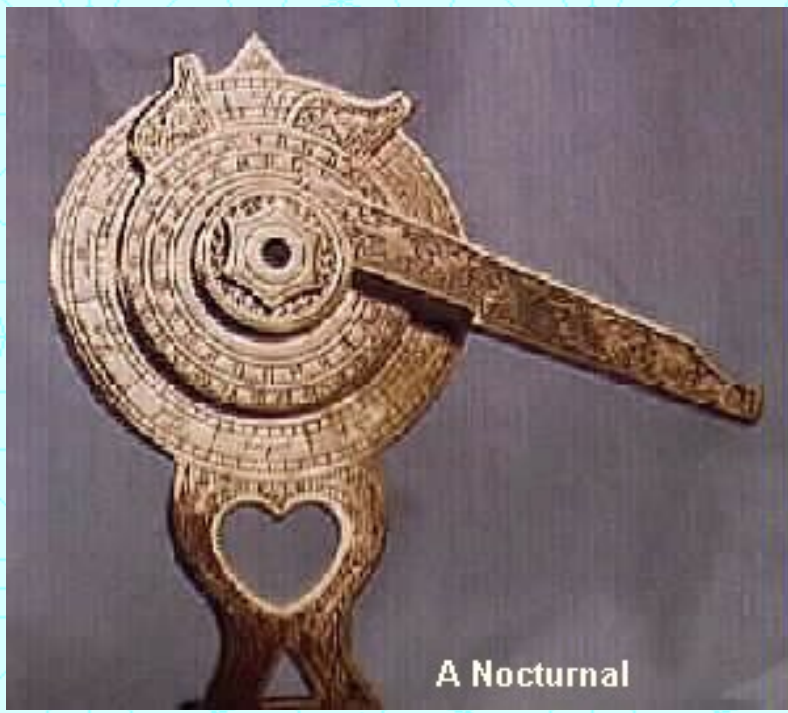

the responsibility of the ship's boy to turn the glass every half-hour in order to measure the time until the watch changed. Since the sandglass was always running a little slow or fast, it was checked daily against the times of sunrise, sunset, or midnight. Midnight could be determined by using a *nocturnal*, a nifty little tool which tells the time of the night by the rotation of stars around the celestial pole.

3. The First Voyage Failures.

After navigating successfully across the Atlantic using his familiar dead reckoning methods, Columbus tried to find his latitude using the quadrant on October 30, 1492. At the time, he was at Puerto de Mares, Cuba, usually identified with the modern Puerto Gibara, at about 20 degrees North latitude. But the result he obtained from the quadrant was 42 degrees. He made another reading from the same place on November 2, and got the same flawed result.

Continuing along the coast of Cuba, Columbus again tried a quadrant latitude reading on November 21, and again came up with 42 degrees. Columbus was by now aware that the quadrant reading was incorrect, but he dutifully recorded the reading in his log anyway -- he blamed the quadrant for the bad result, and remarked that he would not take any more readings until the quadrant could be fixed.

Columbus made two separate attempts to measure his latitude by two different methods on December 13, while anchored in a harbor in northern Haiti. Columbus had read works by the Greek astronomer Ptolemy, and he knew that Ptolemy often referred to a city's latitude according to the length of daylight at the summer

solstice (more northerly places have longer daylight at summer solstice). December 13 was the day after the winter solstice in 1492, which is just as good for latitude measurements (because: the length of daylight at summer solstice is about the same as the length of night at winter solstice). Columbus took the opportunity to measure the length of daylight, finding that the day was 10 hours long. This is also a fairly bad result, but Columbus did not convert the daylight measurement into a latitude, probably because he did not know enough trigonometry to do so.

That night, he made his second attempt to determine latitude within 24 hours. Going back to the quadrant, he again tried to determine the altitude of the North Star, and this time got a reading of 34 degrees -- still far from his correct latitude of 19 degrees.

Finally, on February 3, 1493, while on the return voyage, Columbus tried to determine the altitude of Polaris using both the quadrant and astrolabe; but the waves were so high he could not get a reading.

The quadrant readings Columbus obtained on his first voyage are horrible by any standard. Some have suggested that Columbus mistook another star for Polaris, but that seems ridiculous: Columbus used the stars of Ursa Minor to tell time at night, so he was very familiar with that constellation. In 1983, James E. Kelley, Jr. provided the solution to the mystery: as mentioned above, many quadrants in maritime museums have tangent scales. If Columbus misread the scale, he might have recorded the tangent of his latitude (without the decimal point) instead of his actual latitude. If that were the case, Columbus's measurements would only be wrong by a couple of degrees or so, which is not bad considering the technology.

In any case, it is clear that at this point in his career Columbus was not familiar enough with celestial techniques and tools to use them successfully. So it is not surprising that on his second voyage, there is no record that Columbus attempted to use celestial navigation (except for the fraudulent [eclipse longitudes](#)). Instead, he stuck to the tried and true dead reckoning practice of "rhumblin sailing", keeping a constant west-by-south course the whole way from Gomera to Dominica in the West Indies.

4. The Third Voyage: Some Improvements?

In 1498, Columbus sailed from Spain with six ships of supplies for the settlers on Hispaniola. This is the only voyage on which Columbus made regular and serious attempts at celestial navigation. However, the results he obtained were quite poor, even by the standards of his day.

When he reached the Canary Islands, Columbus split his fleet: three ships would sail WSW, direct for Hispaniola, while Columbus himself would take the other three ships southward to the Cape Verde Islands, and then west. The reasons for this maneuver are still debated.

On the passage west from Cape Verde, he made a series of observations of the North Star to determine his latitude. According to Columbus, the North Star varied from 5° to 15° above the horizon, depending on the time of the night. Actually the North Star was about 3.5° from the celestial pole in 1498, so its total movement in altitude should have been seven degrees, not ten. (This 3.5 degree figure was known to navigators of that era trained in celestial techniques. This is evidence that Columbus was still unfamiliar with celestial navigation.)

The island of Trinidad lies close to the coast of Venezuela, and is separated from the mainland by two straits, which Columbus named *Boca del Sierpe* (serpent's mouth) and *Boca del Drago* (dragon's mouth). Columbus tried to measure the distance between these two straits using celestial observations. Here's a quote from a letter Columbus wrote to the King of Spain:

"I found that there between these two straits, which, as I have said, face each other in a line from north to south, it is twenty-six leagues from the one to the other, and I cannot be wrong in this because the calculation was made with a quadrant. . . . In that on the south, which I named *la boca de la Sierpe*, I found that at nightfall I had the pole star at nearly five degrees elevation, and in the other on the north, which I named *la Boca del Drago*, it was at almost seven."

The true altitudes of the North Star at these places (in 1498) would have been about 12.8° and 13.5° respectively; so Columbus's errors were about 8 and 6 degrees. This is very poor observation by any standard. Shortly after this, Columbus took ill

and there were no further recorded attempts at celestial observation for the rest of the voyage.

5. The Fourth Voyage

Not much of Columbus's own writing about the fourth voyage survives today. But we do know that while marooned on the north coast of Jamaica, he found his latitude to be 19° , which is within a degree of the correct number. This high accuracy could only have been achieved if Columbus had been using celestial techniques. It also suggests that even late in his life, Columbus continued to be fascinated with the latest navigational methods, and continued to learn.



Return to [The Columbus Navigation Homepage](#).

Latitude

Changed Knowledge of the World



What Changed



Without Latitude

In 1440 European Sailors Only Knew



But With Latitude
In 1516 They Knew

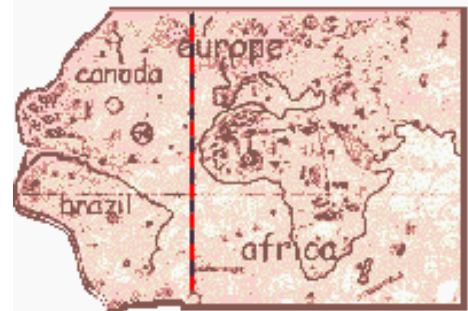

[Ships](#)



[Beacons](#)



[Maps](#)



[Latitude](#)



[Compass
Roses](#)



[Earth's
Magnetism](#)



[Traditional
Sailing](#)



[Science of
Sailing](#)



[Coastal
Navigation](#)



[Ocean
Currents](#)



[Ocean
Weather](#)



[Longitude](#)



[Polynesian
Astronomy](#)



[Math in
Maps](#)



[Calendars](#)



[Site Map](#)



[Net
Resources](#)



[Learning
Page](#)

Portuguese Latitude
Scale circa 1516
(blue/red rectangles,
approx. double
actual size)

sepia maps ©
[Huntington Library](#)

Last modified
9/8/2002 © 1998-
2000 [p seed](#)

SITE AWARDS



[Send Comments](#)

Why world navigation
was impossible in
[1421](#)





Celestial Navigation Before 1400

Before the 1400s Pacific Islanders, Persians, Arabs, inhabitants of Indian Ocean islands such as the Maldives traversed the open seas. While all depended fundamentally upon the ocean's currents and winds, they used the heavens for navigation, since stars and planets were their most dependable "landmarks" on open oceans.



Before scientific navigation, Indian and Pacific Ocean sailors created detailed star maps in their minds and elaborate ways of remembering them. Arab Indian Ocean navigators used sounds--relying on poetic verses--to remember the stars and their position. [Polynesians and Micronesians](#) used elaborate visual images--darting parrot fishes (on left) or trigger fish (on right) or even the circular base of a gourd, lines burnt in to show the meridian of Hawaii. Polynesians and Micronesians, who sailed the greatest distances--thousands of miles across open oceans--created the most elaborate star maps. [Hawaiian Star Map](#) or [Micronesian Star](#)



[Chart](#) at other sites.

Both Polynesians and Micronesians also created elaborate compasses using the stars--while traditional Indian Ocean sailors did not. When the Chinese developed a compass for navigation in the 11th century, it was quickly adopted in the Indian Ocean and Europe, but not the Pacific where traditional [Hawaiian Star Compass](#) or [Micronesian Star Compass](#) were adequate for navigation. (Both compasses elsewhere on the net.)

But none of these techniques of celestial navigation relied upon science. All were good enough for navigating when the winds and currents were predictable. But none of these techniques were adequate for the combination of intense storms and lengthy calms in the South Atlantic.



On-Line Sources

Micronesia, Polynesia, and Melanesia are the three divisions of the Pacific Islands peoples created by the French explorer de Surville after his voyage in 1828, and continue in use today.

| [Introduction to Hawaiian Navigation](#) | [More on Hawaiian Navigation](#)

Micronesia: [Legendary Micronesian Navigator Mau Piailug](#) | [Introduction to Micronesian Navigation](#) | [Documentary on Micronesian Navigation](#)

Polynesia: [Maori Star Knowledge](#) (Polynesian Voyagers. The Maori as a Deep-sea Navigator, Explorer, and Colonizer)

Land-based peoples' use of celestial navigation

[Lakota \(Native American\) Star Maps](#)

Classic Books on Polynesian & Micronesian Navigation



Micronesia: Thomas Gladwin. *East is a big bird; navigation and logic on Puluwat atoll* Cambridge, Mass., Harvard University Press, 1970

Richard Feinberg, *Polynesian seafaring and navigation : ocean travel in Anutan culture and society* Kent, Ohio : Kent State University Press, c1988.

Polynesia: David Lewis, *We, the Navigators : The Ancient Art of Landfinding in the Pacific* Sir Derek Oulton, editor. 2nd ed. Honolulu : University of Hawaii Press, 1994

Ben R. Finney, *Hokulea : The Way to Tahiti* New York : Dodd, Mead, c1979.

Ben R. Finney, *Voyage of Rediscovery* Berkeley: University of California Press, 1994.

Ben R. Finney, [A 1995 Voyage and History of the Controversies surrounding Polynesian Navigation](#) (a must read for advanced students)

[Home page](#) | [The Science of Celestial Navigation](#)

The Columbus Navigation Homepage

Examining the History, Navigation, and Landfall of Christopher Columbus

This and related pages copyright © 1997-2000 by Keith A. Pickering

[Site Map](#)



Sebastiano del Piombo painted this portrait thirteen years after Columbus's death.

Columbus's Navigation

Columbus and [dead reckoning](#) navigation.

Columbus and [celestial](#) navigation.

How long was [Columbus's league](#)?

Columbus and [longitude](#).

Columbus's [ships](#).

Columbus's [crew](#).

Where was [Columbus's first landing place in the New World? Visit the Columbus Landfall Homepage](#).



Columbus History

A Columbus [Timeline](#).

The [First Voyage](#), 1492-1493.

The [Second Voyage](#), 1493-1496.

The [Third Voyage](#), 1498-1500.

The [Fourth Voyage](#), 1502-1504.



Columbus Special Topics

[Who *really* discovered America?](#)

Columbus and the [destruction of native peoples](#).

Columbus's [death and burial](#).

A select [bibliography](#) of Columbus literature, with capsule reviews.

The [Columbus Landfall Homepage](#).

Want to know more? Try these [Links to other sites about Columbus and his times](#).

NEW! [Search](#) The Columbus Navigation and Landfall pages.



[About the author](#).

Questions? Comments? Suggestions? Problems with this site?

Send [Email to Keith A. Pickering](#) .



Reviews and Awards for The Columbus Navigation Homepage

These pages have been viewed **7,354,189** times since September 3, 1999.

	This "The History Ring" site is owned by Keith Pickering . Want to join The History Ring ?	
[Skip Prev] [Prev] [Next] [Skip Next] [Random] [Next 5] [List Sites]		

copyright © 1997-2000 by [Keith A. Pickering](#)

This webpage is:

undefined

This page was last updated:

Invalid Date

This access was:

Mon, 06 Sep 2004 20:29:50 GMT

The Age of Exploration Curriculum Guide

Questions or feedback? Email
Education@mariner.org

Explore by: **MENU** or [TIME LINE](#)

INTRODUCTION: [THE AGE OF EXPLORATION](#)

- [THE ANCIENT WORLD](#)
 - [EGYPT](#)
 - [PHOENICIANS](#)
 - [HANNO](#)
 - [HIMILCO](#)
 - [GREECE](#)
 - [CHINA](#)
 - [POLYNESIA](#)
 - [ARAB](#)
 - [IBN BUTTUTA](#)
- [VIKING EXPLORERS](#)
 - [DISCOVERIES ACROSS THE ATLANTIC](#)
- [VIKING SHIPS](#)
 - [THE GOKSTAD, A VIKING LONGSHIP](#)

- [THE KNARR](#)
- [THE OSEBERG](#)
- [THE EVOLUTION OF THE VIKING SHIP](#)
 - [VIKING CREWS](#)
 - [METHODS OF NAVIGATION](#)
- [THE PORTUGUESE EXPLORERS](#)
 - [PRINCE HENRY, THE NAVIGATOR](#)
 - [THE EXPLOITS OF VASCO DA GAMA](#)
 - [PORTUGUESE SHIPS](#)
 - [MAPS AND CHARTS OF THE FIFTEENTH CENTURY](#)
 - [EARLY NAVIGATION METHODS](#)
- [THE EXPLORATIONS OF CHRISTOPHER COLUMBUS](#)
 - [THE FIRST VOYAGE](#)
 - [LIFE ABOARD SHIP](#)
 - [LAND IS SIGHTED!](#)
 - [THE SECOND VOYAGE](#)
 - [THE THIRD VOYAGE](#)
 - [THE FOURTH VOYAGE](#)
 - [THE DEATH OF COLUMBUS](#)

- [THE FIRST CIRCUMNAVIGATION OF THE WORLD](#)
 - [THE TREATY OF TORDESILLAS](#)
 - [FERDINAND MAGELLAN](#)
- [JOHN AND SEBASTIAN CABOT](#)
- [FRANCIS DRAKE](#)
- [THE VOYAGES OF JACQUES CARTIER](#)
- [HENRY HUDSON](#)
- [JAMES COOK](#)
 - [COOK'S SECOND VOYAGE](#)
 - [COOK'S FINAL VOYAGE](#)
- [CONCLUSION](#)
- [THE EVOLUTION OF STEERING SHIPS](#)
- [VOCABULARY](#)
- [TIMELINE](#)
- [BIOGRAPHIES](#)
- [BIBLIOGRAPHY AND SUGGESTED READINGS](#)
- [ACTIVITIES](#)
 - [Teacher](#)
 - [Student](#)

[Click here to return to the Age of Exploration Main Menu.](#)

Copyright ©1996-2000 by The Mariners' Museum

THE MARINERS' MUSEUM, Newport News, Virginia

[New & Exciting](#) > [Collections & Exhibitions](#) > [Research Library & Archives](#) > [Information & Services](#)
[Educational Programs](#) > [Join & Participate](#) > [Museum Shop](#) > [Monitor Center](#) > [Image Collection](#)



John Charles Frémont

home articles news links book search recents <back

LONGCAMP.COM'S FRANCIS DRAKE ANNEX

Introduction

to

DETERMINATION OF LATITUDE BY FRANCIS DRAKE ON THE COAST OF CALIFORNIA IN 1579



In 38. deg. 30. min. we fell with a conuenient and fit harborough, and Iune 17. came to anchor therein: where we continued till the 23. day of Iuly following. *The World Encompassed*

The World Encompassed

[Skip ahead to article.](#)

About 1595, Jodicus Hondius drew the *Portus Novea Albionis* -- a plan of Drake's "convenient and fit harborough" during a stay in London. A year later he published it as a corner inset to his famous Broadside Map. No place like this exists at Drake's reported anchorage at "N.38.deg 30.min."

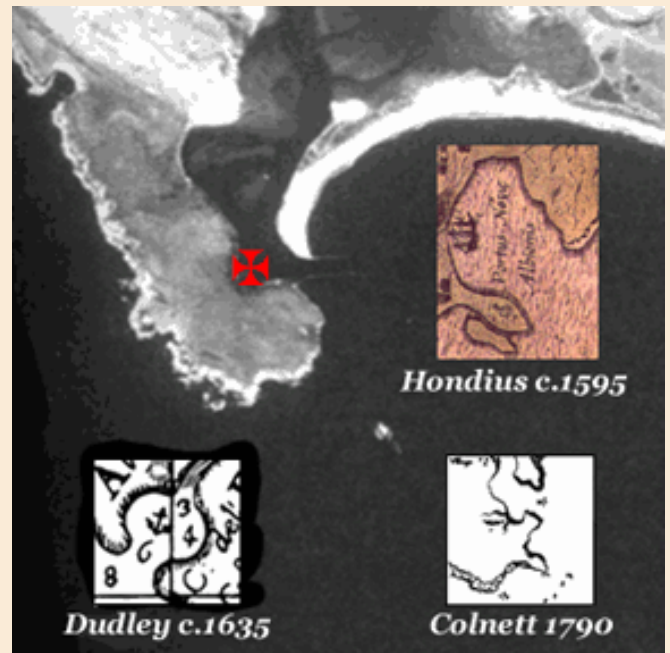

About 1635, Robert Dudley drew *The Map Particulara*, and included **Porto di Nueva Albion** at about **38° 19'**

In 1790, Captain James Colnett sailed into, and charted, what he called the **Port Sir Francis Drake...N38° 21' W123° 00'**

Brian Kelleher studied every detail of Drake's voyage of circumnavigation. He did statistical analysis of all of Drake's determinations of longitude recorded in *The World Encompassed*. He found that, when taken on land, and from positions that can be identified today on modern maps, that Drake's results were +/- 11 minutes of latitude--quite a feat for the day.

The only site that lies within this +/- 11 minutes of latitude of Drake's reported "N.38.deg 30.min" on the Pacific Coast is Campbell Cove (N38° 19'-- W 123° 03') on Bodega Head (large map above). Brian wrote a book called **Drake's Bay - Unraveling California's Great Maritime Mystery**.(see link below).

But Brian had never determined the source of Drake's errors in his determinations. Was it error in sightings? Or, were the instruments of the time incapable of doing better? One day Brian asked me, "Bob, why don't you look at the latitude problem." I did, and we were astonished at what we found.

Many thanks to Andrew T. Young, Astronomy Department of San Diego State University who visited this website and straightened out some of my terminology and provided me with the rule for the obliquity of the ecliptic.

I am not a Drake Scholar. As you can probably guess from the topbar and other contents of this web site, my main interests lie elsewhere. But I have followed the landing site debates for more than twenty years with interest. So, when Brian suggested it, I decided to look at just where a 16th century determination of "N38D. 30.M" at about longitude W123 would have been. Here is what I found.



DETERMINATION OF LATITUDE BY FRANCIS DRAKE ON THE COAST OF CALIFORNIA IN 1579

Many thanks to Dr. Andrew T. Young, Astronomy Department of San Diego State University who visited this website and straightened out some of my terminology and provided me with the rule for the obliquity of the ecliptic.

See also my [news](#) page on my Frémont site for developments at Campbell Cove!

 392978
Visitors

since January 1, 2001.
[FastCounter by bCentral](#)

 Made on a Mac

Copyright ©1999, 2003
[Bob Graham](#)

Nathaniel Bowditch

Born: 26 March 1773 in Salem, Massachusetts, USA

Died: 16 March 1838 in Boston, USA



Click the picture above
to see three larger pictures

[Show birthplace location](#)

[Previous](#) (Chronologically) [Next](#) [Biographies Index](#)

[Previous](#) (Alphabetically) [Next](#) [Main index](#)

Nathaniel Bowditch's father was Habakkuk Bowditch who was a cooper, that is a maker and repairer of wooden casks. His mother was Mary Ingersoll. Although Nathaniel was born in Salem, Massachusetts, his family moved to Danvers, also in Massachusetts, while he was still a baby. After a few years, when Nathaniel was seven years old, they returned to Salem. As Albree writes in [8]:-

The first 50 years of Bowditch's life revolved around Salem, Massachusetts, a compact seafaring town along the picturesque north shore, 16 miles north of Boston.

This was a hard time for the Bowditch family. Habakkuk Bowditch's business collapsed and the family hit really hard times financially. Although Nathaniel went to school until he was ten years old, his formal education had to end at that point and he began working in his father's cooperage shop. After two years of helping his father, Nathaniel became an apprentice clerk in the ship's chandler shop of Hodges and Ropes in Salem in 1785. This shop dealt in provisions and supplies for ships. In 1790 Bowditch, aged seventeen by this time, changed his employers and began working for the shop of Samuel C Ward.

Although Bowditch was working as a clerk, he was educating himself throughout this period. Reingold

writes in [1]:-

... he acquired skill in languages and considerable knowledge of mathematics and other sciences through reading and study. Bowditch's scientific career was largely one of self-education; the United States of his day afforded very little opportunity for research in astronomy and mathematical physics.

There was one way in which Bowditch was lucky. Richard Kirwan (1733-1812) was an Irish chemist who made contributions in several areas of science. Kirwan was elected to the [Royal Society of London](#) in 1780 and helped found the Royal Irish Society some years later. A privateer from Salem, that is a sailor licensed to attack enemy shipping, had intercepted a ship carrying Kirwan's library between Ireland and England and having captured it brought Kirwan's library back to Salem where it was available and used by Bowditch from June 1791. Bowditch had begun to learn algebra in 1787 and two years later he began to study the differential and integral calculus. He learnt calculus so that he might study [Newton's Principia](#) and in 1790 he learnt Latin which was also necessary to enable him to read [Newton's](#) famous work. Later Bowditch learnt other languages in order to study mathematics in these languages; in particular he learnt French in 1792.

Between 1795 and 1799 Bowditch made four sea voyages on merchant ships, and in 1802 he was in command of a merchant ship of which he was also a joint owner. Four of these voyages were to the East Indies while he made one voyage to Europe. The fourth journey was to Philippines while his last voyage was to Sumatra. This was not a period when Bowditch put his studies to one side, on the contrary there was much time at sea for him to carry on his studies and he perfected his French at this time. On his voyage of 1802-03 he read the first volume of [Laplace's](#) *Traité de mécanique céleste* which had been published in 1798. By June 1806 Bowditch had read the first four of [Laplace's](#) five volumes (the fifth volume was not published by [Laplace](#) until 1825).

In March 1798 while Bowditch was back in Salem between voyages, he married Elizabeth Boardman but sadly she died seven months after the wedding. In 1800, before he made his last voyage, Bowditch married for the second time. His second marriage was to Mary Ingersoll who was a cousin and together they had eight children.

Bowditch was now coming up in the world and he gave up his career as a sailor in 1804 to move into the business world. In that year he became president of the Essex Fire and Marine Insurance Company in Salem and under his leadership the Company prospered despite difficult conditions due to the war of 1812 and other political problems. During the years of his presidency of this Company Bowditch undertook mathematical and astronomical investigations which gave him a high reputation in the academic world.

His *New American Practical Navigator* (1802) began as a project to correct and extend the work of John Hamilton Moore. In fact he published the first American edition of Moore's *Practical Navigator* in 1799, having collaborated with his brother on making corrections to Moore's work. In fact Bowditch loved to

carry out complex mathematical computations and the task of checking and correcting Moore's work was one he greatly enjoyed. He published a second edition in 1800, but by the time he came to publish a third edition he had changed Moore's book in such a major way that it was now sensible to publish the work under his own name which accounts for his 1802 publication.

Bowditch had already received high recognition for his academic contributions, including election to the [American Academy of Arts and Sciences](#) in 1799. He was offered the chair of mathematics and physics at Harvard in 1806 but he turned it down. In 1804 he had published an article on observations of the moon, and in 1806 he published naval charts of the harbour at Salem and several other harbours. More scientific publications followed such as one on a meteor explosion in 1807, three papers on orbits of comets (1815, 1818, 1820), and in 1815 he studied [Lissajous](#) figures while studying the motion of a pendulum suspended from two points.

Harvard University was not the only one to offer Bowditch a chair. He was also offered one by West Point and, in 1818, he was offered the chair at the University of Virginia. However, Bowditch had a salary from the Essex Fire and Marine Insurance Company which was 50% higher than the \$2,000 which Virginia offered him. Bowditch refused all the chairs of mathematics he was offered.

Bowditch's translation of the first four volumes of [Laplace](#)'s *Traité de mécanique céleste* was completed by 1818 but he would not publish it for many years. Almost certainly the cost of publication caused the delay, but Bowditch did not just put the work on one side after 1818 but continued to improve it over the succeeding years. Bowditch was helped by [Benjamin Peirce](#) in this project and his commentaries doubled the length of the book. His purpose was more than just an English translation. He wanted [1]:-

... to supply steps omitted in the original text; to incorporate later results into the translation; and to give credits omitted by [Laplace](#).

By this time Bowditch had a high international reputation for he had published articles in British and Continental journals as well as in American ones. We have already noted his election to the [American Academy of Arts and Sciences](#) in 1799. He was elected to the American Philosophical Society in 1809, the [Royal Society of Edinburgh](#) and the [Royal Society of London](#) both in 1818, and the [Royal Irish Academy](#) in 1819.

In 1823 Bowditch left the Essex Fire and Marine Insurance Company in Salem and became an actuary in the Massachusetts Hospital Life Insurance Company. Albree writes in [8]:-

When Bowditch moved from Salem to Boston in 1823, he moved 2,500 books, more than 100 maps and charts, and 29 volumes of his own manuscripts. As president of the Massachusetts Hospital Life Insurance Company, he enjoyed enough material success so that he could afford the \$12,000 it cost to have his translation of [Laplace](#) published (1829-1839).

The work [6] is a reprint in 1966 by the Chelsea Publishing Company of Bowditch's translation. The publisher gives this description of the work:-

*The present work is a reprint, in four volumes, of Bowditch's English translation of Volumes I-IV of *Traité de mécanique céleste de mécanique céleste* [Duprat, Paris, 1798-1805]. The various volumes of the translation were originally published in 1829, 1832, 1834 and 1839, respectively [Hilliard, Gray, Little and Wilkins, Boston], under the title *Mécanique céleste*, which is here translated. The memoir on the life of Bowditch, which originally appeared in Volume IV, has been transferred to Volume I.*

We should note that the memoir on the life of Bowditch originally appeared in Volume IV since this volume was not published until 1839, the year after Bowditch died.

In 1969 by the Chelsea Publishing Company published [4] which is a reprint of the French original of [Laplace](#)'s fifth volume. The publisher describes this is follows:-

*The present work is a textually unaltered reprint of Volume V of *Traité de mécanique céleste*, first published in 1825 [Duprat, Paris] It constitutes the fifth volume of a set, the first four of which are Nathaniel Bowditch's English translation of *Traité de mécanique céleste*. Although Bowditch did not make a translation of this fifth volume, he did make use of relevant portions of this volume in his running commentary in each of the four translated volumes.*

Rothenberg in [9] writes of the value of Bowditch's English translation:-

It would be difficult to overestimate the value of Bowditch's translation and commentary to American physical astronomy during the first half of the nineteenth century. The work marked the beginning of American participation in the field of celestial mechanics. Not only did it allow the poorly trained professors of mathematics in American colleges to explore the wonders of French celestial mechanics, but it also became an essential part of the education of some of Bowditch's successors in the field.

Reingold, however, in [1] notes that:-

Printed in a small edition, the work was perhaps more widely admired than read, simply serving to confirm the translator's already high reputation.

Article by: [J J O'Connor](#) and [E F Robertson](#)

[List of References](#) (10 books/articles)

[A Quotation](#)

[Mathematicians born in the same country](#)

[Cross-references to Famous Curves](#)

[Lissajous Curves](#)

Honours awarded to Nathaniel Bowditch

(Click a link below for the full list of mathematicians honoured in this way)

[Fellow of the Royal Society](#)

Elected 1818

[Fellow of the Royal Society of Edinburgh](#)

[Lunar features](#)

Crater Bowditch

Other Web sites

[Nathaniel Bowditch Initiative](#)

Previous	(Chronologically)	Next	Biographies Index
Previous	(Alphabetically)	Next	Main index
History Topics	Societies, honours, etc.		Famous curves
Time lines	Birthplace maps	Chronology	Search Form
Glossary index	Quotations index		Poster index
Mathematicians of the day		Anniversaries for the year	

JOC/EFR July 2000

[School of Mathematics and Statistics](#)
[University of St Andrews, Scotland](#)



The URL of this page is:

<http://www-history.mcs.st-andrews.ac.uk/Mathematicians/Bowditch.html>



Video Tapes

Topic Area	Physical Science
Title	Underground Railroad: Connections to Freedom and Science
Enterprise	Earth Science
Length/Year	34 minutes/1999
Media	1/2" VHS
Item Number	008.0-10V
Price	\$16.00
Grade Level	Grade 6-12
National Standards	History, Astronomy, Technology, Mathematics, Earth System Science

In July 1998 President Clinton signed a bill into law that would recognize and preserve the Underground Railroad, the South/North escape routes used by freedom-seeking slaves during the 19th century. Specifically, the law authorized the National Park Service to physically link the Railroad's "safe houses," to produce educational materials about the Railroad, and to otherwise commemorate this important part of our nation's history. This fascinating video is the result of a collaboration between the National Park Service and NASA educational resources.

Slaves traveling the Underground Railroad, usually on foot, depended on celestial navigation to find their way northward. They continually looked to the Big Dipper and the North Star for direction. The purpose of this video is to increase student awareness of the Underground Railroad and the role celestial navigation played in the Railroad's success. The video also highlights the importance of modern Global Information System technology in reconstructing historical topographies and finding the exact route of the Railroad. By combining amazing historical facts-such as the use of handmade quilts for communication with mathematics, remote-sensing technology, earth system science, and astronomy, the video presents an educational experience that is dynamic, moving and broadly cross curricular.



ION INSTITUTE OF NAVIGATION
NEWSLETTER
 Volume 10, Number 1 The Quarterly Newsletter of The Institute of Navigation Spring 2000

THE STATUS OF AVIATION-RELATED IMPROVEMENTS
 By Melvin J. Zeltser

SA FADES AWAY

Issue This Issue:

The White House on SA	2	GPS Select Out Events	20
Local Area Selective Availability	3	From the Editor	
Team Based Mode	5	What a Difference a Day Makes	27
GPS III and Modernization	7	Person's Corner	
Smart Weapons	7	Levin and Clark's Expedition	6
GPS Selective Access Restrict WRC	8	Calendar	6
		GPS Around the Globe	
		Issues, Action News, and more	22

The Institute of Navigation • 1000 Diagonal Road, Suite 400 • Alexandria, Virginia 22314

The Status of Aviation Related Improvements

By Melvin J. Zeltser

This article provides a status report of the key technical issues associated with the implementation of improvements to GPS for aviation use, and includes coverage of the Wide Area and Local Area Augmentation Systems (WAAS and LAAS), as well as the new civil signals supported by the White House. Before these subjects are addressed, a few comments are offered regarding the need for WAAS and LAAS given that the White House just announced plans to set selective availability (SA) to zero.

There is little doubt that, without SA, the accuracy of GPS will improve to about 1020 m (95 percent probability). Most existing receivers would have a reduction in the integrity function's false alarm rate, and new receivers could be designed to increase availability of the receiver's autonomous integrity monitoring function. However, this accuracy is still not adequate for precision approaches, and more important, setting SA to zero does not address aviation's safety/integrity requirement (i.e., timely notification to the user within a few seconds when the GPS signals should not be used for a particular operation). The bottom line is that, even though setting SA to zero reduces measurement errors, it has a small impact on the need for and design of WAAS and LAAS ground systems and avionics.

Status: WAAS Accuracy and Integrity

WAAS provides the following augmentations to GPS: differential corrections, an estimate of the error bounds in the differential correction, and a ranging signal. This data is broadcast via a geostationary communications satellite in a form that can be received by a GPS receiver capable of decoding the WAAS message. The differential corrections are transmitted as two components: fast corrections to overcome clock errors and slow corrections to overcome ephemeris errors and map the propagation delay through the ionosphere. The rate of the fast corrections can be reduced when SA is set to zero. The ionospheric mapping is transmitted as vertical delay corrections at the vertices of an imaginary latitude/longitude grid (5° by 5° at an altitude of 350 km). All corrections are generated in a WAAS Master Station (WMS) using range measurements at L1 and L1/L2 from WAAS Reference Stations (WRSs) distributed

throughout the service volume. In the WAAS Phase I system, the 2 s accuracy currently achieved is about 1.52 m horizontally and 23 m vertically. This accuracy exceeds the WAAS accuracy requirements by a significant margin.

The challenging issue in the aviation application is the need to “guarantee” that the errors in the corrections are bounded to levels that would cause the probability of hazardous misleading information (HMI) to be less than 10^{-7} during any landing (150 s interval). This is the WAAS integrity requirement. It is achieved in part by the monitor design in the WMS with corresponding fault detection monitors and an algorithm (in the avionics) that is a function of two parameters measured and transmitted by the WMS: User Differential Range Error (UDRE) and Grid Ionospheric Vertical Error (GIVE). UDRE is a bound on the error in the clock and ephemeris corrections, and GIVE is a bound on the corrected ionospheric delay error. The receiver algorithm generates Horizontal and Vertical Protection Levels (HPL and VPL) that are compared with a threshold preset in the receiver. For example, Vertical Alert Limit (VAL) values of 50, 20, or 12 m are used as thresholds depending upon the classification of the approach.

Figure 1 is a block diagram of the WAAS Phase I showing the 25 WRSs feeding 2 redundant WMSs. Each WMS contains a corrections processor (CP) and a safety processor (SP). The CP uses carrier-smoothed data from each WRS as an input to the algorithm that estimates the corrections and error bounds. The error bounds estimated by the CP are derived from measurements having low level noise inputs. However, these error bounds cannot be used to determine integrity because the CP and its software are certified to level D (and not level B, which is required for landing system integrity). The SP contains an operating system and software certified to level B, and is intended to ensure that error bounds for UDRE and GIVE adequately reflect all “fault” conditions (including rapid changes in the ionosphere). In the initial WAAS Phase I implementation, the SP used minimally smoothed data; this resulted in large values for the UDRE and GIVE parameters, which in turn led to low availability and continuity of service. Also, an initial set of analyses that calculated probability of HMI did not show that the GIVE bounded true errors in the event of an ionospheric trough (i.e., rapid changes in the ionospheric delay in a relatively small region), and some cases of HMI were not detected by the monitor.

WAAS Issues to be Resolved

To expedite the certification of WAAS for operational use, FAA formed two panels: a WAAS Integrity Performance Panel (WIPP) and an Independent WAAS Integrity Panel (IWIP). The role of the WIPP is to define a feasible incremental implementation of the WAAS integrity function. WIPP members include FAA, Stanford University, Ohio University, Jet Propulsion Laboratory, Zeta Associates, MITRE Center for Advanced Aviation System Development (CAASD), and Raytheon. Initial WIPP efforts are focused on providing a precision approach with a VAL of 50 m by retaining the current architecture and making changes to the algorithms in the SP based on new ideas and prototype results. The second WIPP effort will determine the SP’s architecture and algorithms that can support a VAL of 12 and 20 m. In addition to the architecture and algorithm effort, the WIPP will provide the analytic justification for all assumptions and validate the completeness of the monitor. The IWIP members will use the documentation to verify that the integrity requirements are being satisfied. The IWIP comprises experts from FAA, MITRE/CAASD, Stanford University, Ohio University, BoozAllen & Hamilton, and the Naval Air Warfare Center. The individuals on this panel have had no direct involvement with the WAAS project, but have LAAS integrity expertise.

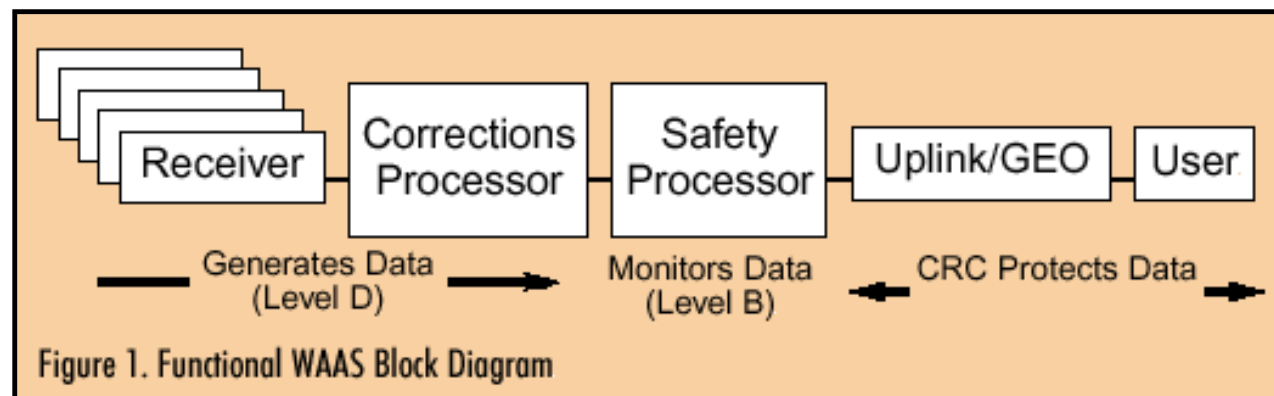

The key technical activities that need to be done are the following:

- *Define the trade space for the correction bounding parameters.*
- *Develop techniques to reduce measurement noise.*
- *Modify the SP algorithms that estimate clock/ephemeris residuals (i.e., ensure that UDRE is a suitable upper bound on*

clock/ephemeris in the presence of measurement noise).

- *Modify the SP algorithms that estimate GIVE residuals under quiet and severe ionospheric storm conditions.*
- *Conduct a comprehensive fault detection analysis.*
- *Develop and prototype a new architecture and algorithms that will improve UDRE and GIVE residuals for a VAL of 20 and 12 m.*
- *Identify the schedule and cost impacts of achieving a VAL of 20 and 12 m.*
- *Compare the performance and cost with user expectations.*

Status: LAAS Developments

LAAS provides these augmentations to GPS: differential corrections, an estimate of the error bounds in the differential correction, and an additional ranging source, if needed. These functions are the same as those of WAAS, but the implementation is different. In LAAS, the differential corrections are transmitted over a VHF communications channel as a single value correcting for all errors impacting the pseudorange and range rate for each satellite. The corrections are generated from inputs from 3 to 4 reference stations. The accuracy of the differentially corrected position is about 1 m. Prototype LAAS ground stations have demonstrated the ability to satisfy CAT I integrity requirements. The challenging LAAS issue is to “guarantee” that the errors are bounded during allweather landing (i.e., including zero ceiling conditions).

The additional ranging source, if needed to improve availability, is provided by an airport pseudolite (APL), which transmits a pulsed signal on the GPS frequency. The APL has been prototyped, and suitable standards have been developed by RTCA. A LAAS CAT I specification has been developed and is being validated by the FAA.

The governmentindustry partnership between FAA, Honeywell, and Raytheon is producing CAT I LAASs that are planned to be type certified next year. FAA plans a LAAS procurement starting in 2003.

Resolving Key LAAS Issues

The key technical activities that still need to be done are the following :

- *Validate the CAT I LAAS specification.*
- *Type certificate industry’s CAT I LAAS ground facilities.*
- *Start FAA procurement of CAT I LAAS systems.*
- *Develop and validate CAT III LAAS integrity concept.*
- *Develop a CAT III LAAS specification.*

Status of Additional Civil Signals

In March 1996, a presidential decision directive made GPS a dualuse, dualservice system. The White House announced (during 1998 and 1999) that two civil signals will be provided: a C/A code will be added to L2 (signal at 1227 MHz), and a new L5 signal will be provided at 1176 MHz. The C/A code on L2 is intended for surface applications able to tolerate occasional interference from the many radars operating in the 12151385 MHz band. The L5 signal is located in the Aeronautical Radio Navigation Service band (i.e., 9601215 MHz), where all emitters are managed by civil aviation authorities for safetyoflife applications. To minimize the impact on existing systems, the new L5 civil signal will have 6 dB more power than the L1 and L2 C/A signal and a higher chipping rate (i.e., 10 vs. 1 MHz), and the receiver will be required to incorporate a “pulse blanker,” and improved selectivity. In addition, current systems in the band (i.e., DME, TACAN, and JTIDS/MIDS) may be “rechanneled” to assure proper L5 reception.

An incremental implementation plan is being developed for these civil signals under the oversight of the Interagency GPS Executive Board. The implementation plan being considered by the GPS Joint Program Office is to add the C/A code on L2 starting with some Block IIR satellites, add both the L2 and L5 signals to the Block IIF satellites, and include both signals in the GPS III modernization. A constellation of at least 24 space vehicles having the L5 signal is not expected before about 2014.

L5, when operational, will provide two primary benefits to safetyoflife applications. First, the L5 signal removes the singlefrequency vulnerability by duplicating the WAAS and LAAS service on L5. (Will it be duplicated at L2 also? — Editor) In addition, L1/L5 avionics could use both frequencies to measure ionospheric delays thereby improving the availability of precision approach service.

What Needs To Be Done?

Significant progress has been made in defining the L5 signal characteristics, conducting theoretical analyses and simulations of receiver operation in the anticipated interference environment, and initiating an L5 standards development activity in RTCA. The L5 signal specification has been completed and is scheduled for RTCA SC159 plenary review in June.

The key technical activities that still need to be done are the following:

- *Confirm the characterization of the RFI environment by direct measurement of DME, TACAN, JTIDS/MIDS, and radars.*
- *Confirm the operation of a receiver with pulse blanking in the RFI and L5 pulsed pseudolite environments.*
- *Confirm the ability to reassign DME and TACAN frequencies.*
- *Confirm the performance of WAAS and LAAS in the presence of the new military (M) code on L1 and L2 (e.g., validate the performance of the WAAS reference stations when the M code is added to L1 and L2).*
- *Complete the development of avionics standards for L5 and L1/L5 operation.*
- *Develop international standards for L5 and L1/L5 operation.*
- *Develop a plan to upgrade WAAS and LAAS to use the L2 and L5 civil signals.*

—Melvin J. Zeltser, with The MITRE Corp.'s Center for Advanced Aviation System Development, is head of the department responsible for navigation support to the FAA.

SA Fades Away

With the press of a button at midnight GMT (8 p.m. EDT) the first day of May, the government shut down selective availability (SA) and opened up what many feel will be a boom market in GPS applications. As one government spokesman dramatized it, a person with a Kmart receiver woke up the next morning finding that “they’re suddenly 10 times more accurate.”

The military, by intensive work on countermeasures, beat the inevitable 2006 deadline for turning SA to zero, by almost six years. At a White House briefing announcing President Clinton’s decision, Dr. Arthur L. Money, assistant secretary of Defense, said the pacing item for the decision was the ability to jam or deny the more accurate GPS signal to an adversary in a selected region. Once that was achieved, he said — final definitive Navwar tests were completed only last February — “we went forth with the recommendation to the President.”

The decision, surprising in its speed, came the week before the opening of the World Radiocommunications Conference (WRC) in Istanbul, where U.S. delegates are trying to safeguard new spectrum allocations for GPS modernization purposes, and rising interest among other countries in rival satellite navigation systems, such as Europe’s Galileo system.

SA had come to be a Cold War legacy of declining value for national security purposes, officials felt, especially when weighed against the benefits that could accrue to the growing majority of civil GPS users world wide. The widespread use of differential (D) techniques largely negated the effects of the military’s deliberate degrading of the civil signal (called selective availability) that limited accuracies to about 100 meters; civil users routinely achieved less than 10 meters accuracy with DGPS. Differential services still are essential, of course, to provide integrity, as well as for certain safety of life applications in transport, for precision survey and geodetic work and other applications.

Some Benefits

In hailing the removal of SA, the White House noted in a fact sheet that a backpacker with a single lowcost receiver now “will find that the accuracy of GPS exceeds the resolution of U.S. Geological Survey topographical quad maps.” Industry leader Charles Trimble said

the commercial impact will be secondary, that “the real beneficiary is the consumer, and GPS applications in information technology. GPS is a fundamental technology, the basis for all sorts of systems that affect the economy.”

Without SA, GPS in cell phones may become the preferred choice for location services. The FCC has mandated that mobile phones using Enhanced911 service must provide location accuracy of 50 meters 67% of the time, and 150 meters 95% of calls — a requirement now easily surpassed by civil GPS capability. Another burgeoning mass market is in vehicle navigation systems; there are more than 40 million vehicles in the U.S. alone.

Timing data broadcast by GPS — widely used to time stamp financial transactions, synchronize utility networks, TV broadcasts, etc. — improves to within 40 billionths of a second. This could mean telecommunications companies could tighten the spacing between data packets, loading more information on existing optical cables, among other infrastructure benefits.

General aviation pilots, who now sometimes wave handheld receivers out the window, enjoy significantly better positioning/navigation. “GPS without SA would yield aviation safety benefits, including better position information to help runway incursions,” says Phil Boyer, President of the 360,000-member Aircraft Owners and Pilots Assn. Principal aviation benefits will be improvements in Receiver Autonomous Integrity Monitoring (RAIM), used for navigation, and in future use of the FAA’s WAAS/LAAS systems, used for precision approaches. SA had been the main cause error in this system.

Gene Conti, assistant secretary of the Department of Transportation, wouldn’t hazard a dollar estimate of increased receiver sales by U.S. manufacturers as the result of the demise of SA. But he noted that the government has forecast a robust \$8 billion GPS industry in 2000, doubling in three years to \$16 billion, before the announcement.

Prelude to SA Decision

A massive, coordinated push within the government, backed by those intent on halting SA sooner rather than later, resulted in the landmark announcement by Clinton. At the Pentagon, the Joint Staff formed a working group in December 1998, comprised of all four services, the U.S. Space Command, GPS Joint Program Office, and associated agencies such as the CIA, National Air Intelligence Center, Defense Intelligence Agency, Defense Information Systems, National Imagery and Mapping, National Reconnaissance Office and the National Security Agency. After a 14-month thorough review by the working group, the Joint Staff submitted its recommendation Feb. 17 this year. U.S. military allies were notified in April; none protested, officials said. The recommendation was coordinated with the Interagency GPS Executive Board (IGEB), chaired by Defense and the Transportation Department.

Defense Secretary William Cohen notified the White House the week of April 24, President Clinton approved it Friday April 28, and the public announcement was made Monday May 1. That day, Dr. Money told a White House press briefing: “Defense, I believe, has demonstrated the capability to negate GPS signals in a threat area, consistent with military needs and the President’s policy; thus, we can set selective availability to zero. Given the widespread use of GPS for peaceful purposes, we believe this approach is (more) effective than world wide degradation.”

Defense has declined to specify the methods it will employ to deny the GPS signal in a theater of threat, nor the size of an area affected. It is believed that directional groundbased jammers will be the principal element, essentially requiring no satellite or system modifications, according to experts familiar with the military planning.

Perhaps the defining statement at the May 1 White House briefing was by Dr. D. James Baker, head of the National Oceanic and Atmospheric Administration (NOAA). “Now we have one system,” Baker declared. “All of these benefits that have been talked about will come without any receiver upgrades or fees whatsoever.”

A WHITE HOUSE PRESS RELEASE

Statement by the president regarding the United States’ decision to stop degrading global positioning system accuracy

Today, I am pleased to announce that the United States will stop the intentional degradation of the Global Positioning System (GPS) signals available to the public beginning at midnight tonight. We call this degradation feature Selective Availability (SA). This will mean that civilian users of GPS will be able to pinpoint locations up to ten times more accurately than they do now. GPS is a dualuse, satellitebased system that provides accurate location and timing data to users worldwide. My March 1996 Presidential Decision Directive included in the goals for GPS to: “encourage acceptance and integration of GPS into peaceful civil, commercial and scientific applications worldwide; and to encourage private sector investment in and use of U.S. GPS technologies and services.” To meet these goals, I committed the U.S. to discontinuing the use of SA by 2006 with an annual assessment of its continued use beginning this year.

The decision to discontinue SA is the latest measure in an on going effort to make GPS more responsive to civil and commercial users worldwide. Last year, Vice President Gore announced our plans to modernize GPS by adding two new civilian signals to enhance the civil and commercial service. This initiative is ontrack and the budget further advances modernization by incorporating some of the new features on up to 18 additional satellites that are already awaiting launch or are in production. We will continue to provide all of these capabilities to worldwide users free of charge.

My decision to discontinue SA was based upon a recommendation by the Secretary of Defense in coordination with the Departments of State, Transportation, Commerce, the Director of Central Intelligence, and other Executive Branch Departments and Agencies. They realized that worldwide transportation safety, scientific, and commercial interests could best be served by discontinuation of SA. Along with our commitment to enhance GPS for peaceful applications, my administration is committed to preserving fully the military utility of GPS. The decision to discontinue SA is coupled with our continuing efforts to upgrade the military utility of our systems that use GPS, and is supported by threat assessments which conclude that setting SA to zero at this time would have minimal impact on national security. Additionally, we have demonstrated the capability to selectively deny GPS signals on a regional basis when our national security is threatened. This regional approach to denying navigation services is consistent with the 1996 plan to discontinue the degradation of civil and commercial GPS service globally through the SA technique.

Originally developed by the Department of Defense as a military system, GPS has become a global utility. It benefits users around the world in many different applications, including air, road, marine, and rail navigation, telecommunications, emergency response, oil exploration, mining, and many more. Civilian users will realize a dramatic improvement in GPS accuracy with the discontinuation of SA. For example, emergency teams responding to a cry for help can now determine what side of the highway they must respond to, thereby saving precious minutes. This increase in accuracy will allow new GPS applications to emerge and continue to enhance the lives of people around the world.

QUOTES OF THE QUARTER

"This move has the potential to do for GPS what the PC has done for computing, making this powerful information technology far more accessible and affordable to the broad public." *Commerce Secretary William M. Daley on halting selective availability.*

"It appears then as if the FAA is trying to justify a very expensive program (WAAS) with many technical uncertainties (that) does not show a favorable cost-to-benefit ratio until 2015..." *Aron Pinker and Charles G. Smith, ANSER Corp.*



Beyond Belief Life After Selective Availability *By Rob Conley*

Shortly after Selective Availability was discontinued, the GPS Standard Positioning Service (SPS) changed dramatically. The transition as seen from Colorado Springs, Colorado, USA at the GPS Support Center is shown in figure 1. The data were taken using a Trimble SVEeSix receiver positioned at a surveyed location. The position solution errors were generated from four-satellite solutions, using single-frequency measurements.

Can It Be That Good?

The first reaction from many people in viewing the transition data has been, "I don't believe it ... it can't be that good!". Well ... yes it can. The basis for Position/Navigation/ Timing (PNT) performance experienced by the user is a combination of User Range Error (URE) and constellation geometry. The GPS Control Segment is currently maintaining constellation signal-in-space User Range Errors (UREs) at a consistent 1.7 meters (1s). From a constellation management perspective, sustaining an average of 25 operational satellites is providing Root Mean Square (RMS) Horizontal Dilutions of Precision (HDOP) values of about 1.4, and Vertical DOP (VDOP) values around 1.9, for four-satellite solutions. Obviously, all-in-view solutions will generally provide even better geometry statistics. When we put these components together into a global assessment of base GPS performance without considering propagation or receiver contributions, it usually looks like the plot in figure 1. The example is for 5 May 2000, and the plot indicates global horizontal performance at a 95% error threshold level, for four-satellite solutions. Below the plot is a table containing key summary statistics associated with the plot.

With the basic GPS service providing such performance, the most significant SPS error source becomes the singlefrequency ionosphere model. In an analysis we conducted at the GPS Support Center last year covering the month of March, we examined singlefrequency model results against instantaneous dualfrequency measurements taken from the National Satellite Test Bed (NSTB). The bottom line to the analysis was that the single frequency model contributed approximately 3 meters (RMS) to satellite UREs.

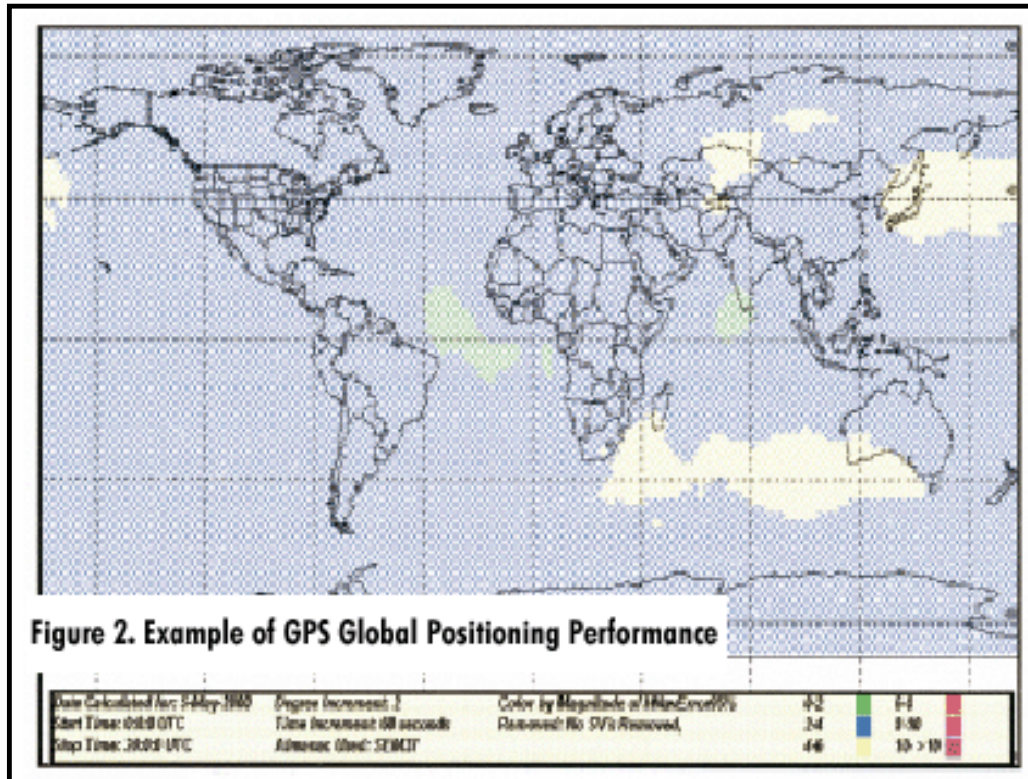
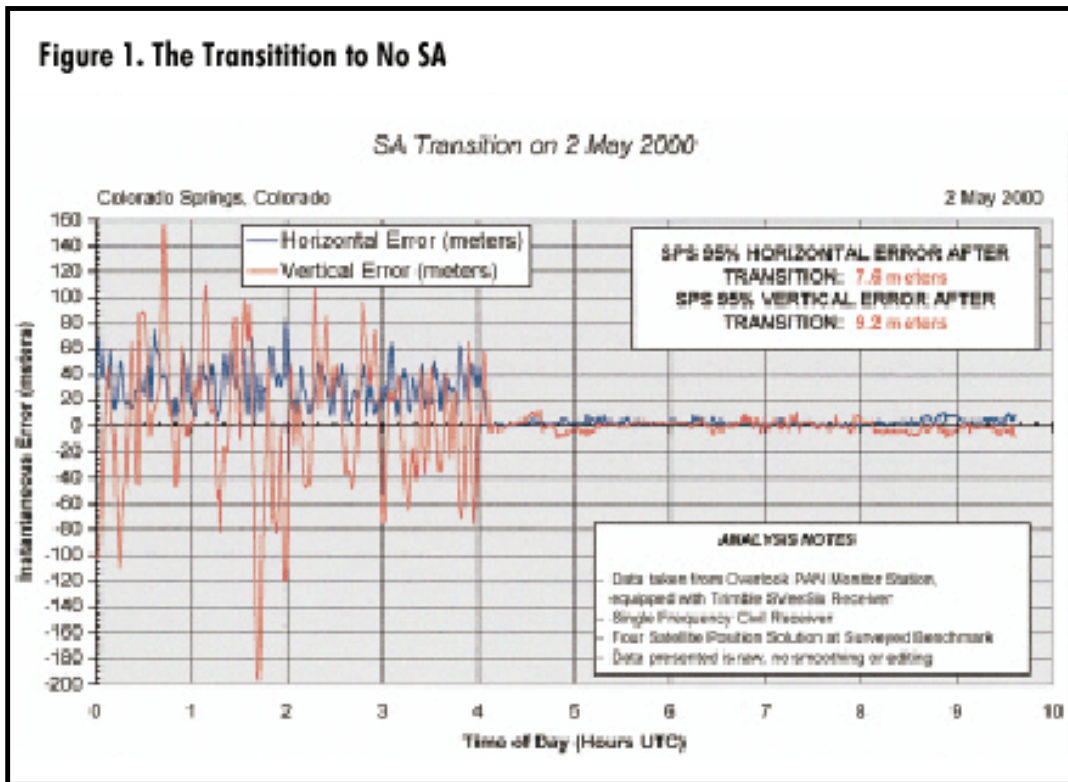

When we examined singlefrequency effects on the foursatellite position solution, vertical error 95% statistics jumped to between 10 and 15 meters.

As the dust settles from this landmark event, users will inevitably wonder what it means to their particular community. In other words, "what does removing SA mean to me?" The answer to this question depends a great deal on who you are. I have provided below some thoughts for several different user groups.

The Aviation User

Aviation applications will in all likelihood be the most visible user group to benefit from the discontinuance of SA, at least in the short term. The primary effect of the improved accuracy will be to improve Receiver Autonomous Integrity Monitor (RAIM) availability to greater than 99.999% for all phases of flight except precision approach, particularly if the avionics suite aids GPS with a barometric altimeter. Even with SA discontinued, precision approach will still require some form of augmentation to ensure integrity requirements are met while providing a sufficient level of availability, and to reduce the probability of Hazardously Misleading Information (HMI) to the lowest possible level.

The Time and Frequency User

Most precise time users may not see significant benefit in the short term after SA is discontinued. This is because most users that depend on precise time transfer currently use techniques such as commonview observations to eliminate almost all the SA effect. Users with time synchronization requirements below the five nanosecond level will still probably use such techniques. Many users may however find that direct access to UTC to within 1020 nanoseconds 95% of the time will be sufficient for their needs. The most likely longterm time/frequency application beneficiaries of setting SA to zero will be communication systems that can realize significant future increases in effective bandwidth use due to tighter synchronization tolerances.

Table 1. Summary of GPS Global Positioning Performance Statistics

Global SIS NAV Assessment	Horizontal Error (meters)	Vertical Error (meters)	Position Error (meters)	Time Error (nanoseconds)
50%	1.2 meters	1.7 meters	2.6 meters	8.7 ns
RMS	1.8 meters	2.5 meters	2.9 meters	9.4 ns
95%	3.1 meters	4.9 meters	6.0 meters	12.7 ns
Average Maximum Magnitude	4.0 meters	7.1 meters	9.3 meters	23.5 ns

Worst Site SIS NAV Assessment *	Horizontal Error (meters)	Vertical Error (meters)	Position Error (meters)	Time Error (nanoseconds)
RMS	2.3 meters	4.5 meters	4.9 meters	12.4 ns
Maximum Magnitude	12.7 meters	36.0 meters	36.9 meters	73.8 ns

The Vehicle Tracking User

Vehicle tracking system needs for precise positioning vary. Tracking an interstate trucker often needs only an accuracy good enough to locate which city the truck is in, whereas, public safety applications can require knowing the precise address of the vehicle. Thus, elimination of SA may have little effect on the trucking application, but will indeed significantly affect public safety's use of GPS. First, current users of Differential GPS (DGPS) for vehicle tracking will in all likelihood drop the need for such. This eliminates the need for sophisticated and costly differential GPS systems, and results in decreased hardware costs at the vehicle (no DGPS required) and software costs at the base station (no DGPS reference stations or special DGPS processing). The loss of these systems will drop the demands on data networks for the transmission of differential correction data. Second, users who are not currently using DGPS will see a marked improvement in performance. Vehicles that used to be reported off the road will now be correctly represented as being on the highway.

The Maritime User

The removal of SA has the potential for significant benefits to maritime use of GPS. These benefits will be seen most directly for navigation in congested waterways or in very poor visibility conditions. The new SPS also provides a great deal more flexibility to waterway management authorities in overseeing and heading off possible navigation problems as commercial traffic increases. A

major benefit will accrue to maritime users that need to navigate to a previous location, since repeatable accuracy has also increased by an order of magnitude. As in aviation, the use of differential services may diminish but will in all likelihood continue for many safetycritical operations due to the increased level of integrity available via a differential broadcast.

The Personal Navigation User

Today, consumers have a variety of options for using GPS for personal navigation. These include invehicle display units, handheld GPS receivers, cellular telephones with GPS and maps, and laptop and palmtop computers with GPS and mapping programs. Without some form of aiding, GPS with SA enabled reported positions with errors up to 100 meters (95%). Several companies have developed a number of techniques to correct for this error, including the use of inertial sensors and mapmatching algorithms, all of which have resulted in increased cost to consumers. Few personal navigation users take advantage of the benefits of DGPS, primarily due to cost and availability. Elimination of SA will in most cases provide an immediate improvement to personal navigation users with no extra effort or cost. The most obvious change to a handheld user will be the fact that the receiver's altitude and velocity values will no longer change dramatically while standing still. Terminating SA should allow manufacturers to produce simpler and less expensive products, resulting in decreased consumer cost and a corresponding proliferation of use.

—*Rob Conley of Overlook Systems Technologies, Inc.,
is Program Director for the DoD's GPS Support Center.*

Tycho Brahe Award

*The next major breakthrough in precision navigation
may well be the brainchild of astronomytrained contemporaries.*

The ION Council is considering the establishment of a new annual ION award, the Tycho Brahe Award, named after the Danish astronomer, for achievements space navigation.

The eligibility requirements are to be reviewed at the June ION Annual Meeting in San Diego. In supporting the award, Len Sugerman, chairman of the Tycho Brahe Award Committee, wrote a refulgent endorsement. "The ION," Sugerman wrote, "can surely become a major player in bringing the frontiers of outer space and discovery to the people."

Sugerman said that for 50 years, ION awards have honored seminal achievements in navigation, and the Tycho Brahe Award continues that tradition, and expands it to space. "Astronomy distinguishes itself from most disciplines in many ways but especially in the mindstretching scales it invokes to describe space, time and the size of objects in the universe," Sugerman said.

"On the horizon is interplanetary navigation, opening up space beyond the limit of earth orbits and travel to the Moon, Mars and other celestial bodies.

"The next major breakthrough in precision navigation may well be the brainchild of astronomytrained contemporaries," Sugerman declared. "A whole new century is dawning. New forces and new players are waiting in the wings to take up the challenges. With determination, imagination, confidence and faith, new space navigation initiatives will surely be developed and expanded."

IAIN WORLD CONGRESS

Links With

U.S. ION ANNUAL MEETING

An international audience will be present for the combined International Association of Institutes of Navigation (IAIN) World Congress / U.S. ION Annual Meeting being held in San Diego June 26–28.

A Plenary Session on Monday morning June 26 opens the three-day meeting that features a rich agenda of 26 separate technical sessions updating U.S. and international developments in navigation / positioning and timing. The Plenary session includes a perspective of where we are now in land, marine and aviation/space uses of navigation and positioning technologies, as well as keynote presentations on GPS and Galileo.

Members of a panel of experts responding to questions during the plenary include Dr. Peter Voersmann, Avionics Zentrum, Germany; Prof. Jac Spaans, Consultant, Netherlands; Olivier Carel, French Ministry of Aviation; Prof. Per Enge, Stanford University; Prof. Gerard Lachapelle, University of Calgary; Dr. A.J. Van Dierendonck, AJ Systems; Prof. Guenter Hein, University FAF, Germany; Dr. Rolf Johannessen, Consultant, UK; Prof. Borje Forssell, University of Trondheim, Norway; Luc Tytgat, European Commission; Col. Douglas Laverro, USAF GPS JPO, and Prof. Brad Parkinson, Stanford University.

New IAIN officers for the next year and other events, such as IAIN awards for outstanding paper and best presentation, will be presented at a closing Plenary session June 28.

The headquarters hotel is the Catamaran Hotel. Information on the conference, hotel reservations, and other data can be found on the ION web site: www.ion.org.

ION GPS 2000

September 19–22
Salt Palace Convention Center
Salt Lake City, Utah

Now that SA has been removed, heightened interest in GPS is drawing attention to the ION's annual GPS conference and exhibition — ION GPS 2000 — being held this year Sept. 19–22 in Salt Lake City, site of the 2001 Winter Olympics.

The world's premier event showcasing the latest developments in GPS technology, sponsored by the Satellite Division of ION, has attracted hundreds of quality papers for the more than 30 technical sessions in six tracks. Exhibitors from top corporate sponsors have signed up for space at the Salt Palace Convention Center. Technical tutorials will precede formal opening of the conference on Sept. 18 and 19. The Little America, the grand dome of Salt Lake City, is the headquarters hotel.

Full registration, for all sessions, ION meals events and other functions, is \$420 for non-members, \$385 for members, on mailed reservations received by August 25; single day registration for sessions is \$170. Information on hotel reservations, and a map of the city, as well as other activities, can be found on the ION web site: www.ion.org.



Portney's Corner Courtesy of Litton G&C Systems

President Thomas Jefferson whose intellect, scientific prowess and foresight led him to realize in 1803 that our continent needed to be explored beyond its border at the Mississippi River. With the acquisition of the Louisiana Purchase, this need became more compelling. Jefferson believed that there was a Northwest Passage, a waterway of adjoining rivers that could connect the Missouri River to the Pacific. Congress approved \$2500 for this expedition. Jefferson selected his secretary, Captain Meriwether Lewis, to organize the "Corps of Discovery" to establish this route and bring back specimens from nature, maps and navigation data. Lewis then chose his close friend Lieutenant William Clark to be his coleader of the "Corps of Discovery."

Lewis received three weeks of studies in celestial observations under Andrew Ellicott eminent astronomersurveyor. He also received tutoring in botany, fossils and more lessons from Robert Patterson in the determination of latitude and longitude. Lewis and Clark carried the necessary instruments for measuring the altitude of celestial bodies (sextant and quadrant), a chronometer for determining longitude and compasses to determine course. They also carried the best available maps of the region, an Astronomical Ephemeris and Nautical Almanac, Practical Introduction to Spherics and Nautical Astronomy and tables for finding latitude and longitude. It is to be noted that Lewis and Clark used an artificial horizon in their celestial observations as the clear horizon was not always available and the terrain elevation above sea level was not generally known. At sea the sextant measured angle to a celestial body which was then corrected for height above sea level (dip angle). Clark maintained a daily record of courses and distances traveled and frequently mapped the regions encountered by taking bearings and estimating distances to references.

The team traveled on a 55 foot masted keel boat and canoes when on the waterways. When they reached their Pacific Coast destination in Oregon territory which they named Fort Clatsop (for the neighboring Indian tribe), Clark estimated that they had traveled 4,162 miles from the mouth of the Missouri to the Pacific. This estimate has been cited to be in error by ~ 1% (40 miles) of the actual distance traveled. It is claimed that Lewis' celestial observations at Fort Clatsop, when reduced to latitude and longitude, would locate

the site within 4 miles of its actual position.

How were these navigational accomplishments achieved?

A. Clark used dead reckoning and Lewis used meridian transits of the Sun for latitude and lunar distances to establish

Greenwich time and longitude.

B. Lewis used eclipse tables to establish longitude and Polaris to establish latitude; Clark used inductive reckoning.

C. Lewis used Viking tables for longitude and meridian transits to establish latitude; Clark used dead reckoning.

D. All of the above.

Clark, versed in surveying and map making, maintained a daily log of courses and distances traveled and transferred the information to his map. Courses were determined from his compass. He could determine the magnetic variation by comparing compass magnetic north to true north. True north could be obtained by taking a bearing of Polaris (which traced a circle approximately 1° in radius around the celestial pole). Knowing magnetic variation he could plot his dead reckoning position relative to true north. He could determine the speed of the boat by timing a log chip dropped in the river along the side of the boat. If the log chip traversed the boat's length in $71/3$ seconds for example, he would know that he was traveling about 5 miles per hour. However, it is doubtful that Clark could achieve a dead reckoning error of 1% without compensatory errors. He relied upon a compass with an inherent error of at least a degree; his estimate of speed and distances was about 5% to 10% if not more.

Determining Longitude and Latitude

Both Lewis and Clark obtained the data for determining latitude and longitude by making equal altitude measurements (before and after noon) of the Sun using the sextant or quadrant and chronometer and were capable of reducing the data. The actual reduction of the data (which was recorded on tabular forms) to establish longitude by lunar distances en route was accomplished at West Point by mathematicians after the expedition was completed. Lewis and Clark were instructed to measure the altitude of the Sun at least two hours before noon, set the instrument down, and wait until the altitude would return to the same altitude verified by observation. The two times were then averaged to establish the time the Sun was on their meridian. This was the local apparent noon. Subtracting the time of noon at Greenwich (obtained from the Nautical Almanac) from the time recorded for the local noon (in Greenwich time) would yield the difference in time of the two locations. Multiplying the time difference by $15^\circ/\text{hr}$ would yield longitude. If the altitude of the Sun were taken and plotted periodically between the initial and final observations, one could determine latitude which would be calculated at the midpoint between the initial and final observations of the Sun when the Sun reached its highest ascension and was on the observer's meridian. This whole procedure was known as determining local apparent noon (Figure 1 and 2). One of the watches could be reset to local time on the basis of this procedure (allowing the chronometer to maintain Greenwich time). The chronometer was regulated prior to the expedition which meant that its error rate was known and could be acknowledged in the computations.

Longitude was to be obtained by performing measurements of lunar distances by Lewis and Clark. Lunar distances was a technique for determining Greenwich time and longitude by measuring the horizontal angle of the Moon to the Sun or one of the selected stars and measuring their altitudes using the sextant. A tedious calculation using a spherical triangle was employed to clear the distance of refraction and parallax effects for each measured altitude and other errors. This information was compared to tabular data in a table to obtain Greenwich time and longitude. This technique was conceived in the 15th century and underwent perfection over the centuries. was a very difficult procedure for most navigators.

Establishing Local Apparent Noon

Assume Lewis and Clark conducted this observation of the Sun and established their position (Figure 1):

Steps in Obtaining

Longitude:

Conversion

Factors Arc time $15^\circ =$

1 hour $1^\circ = 4$ minutes

$15' = 1$ minute $1' = 4$

seconds Arc

Equivalent $^\circ$ degree

of arc ' minute of arc

" second of arc

$1^\circ = 60'$ $1' = 60''$

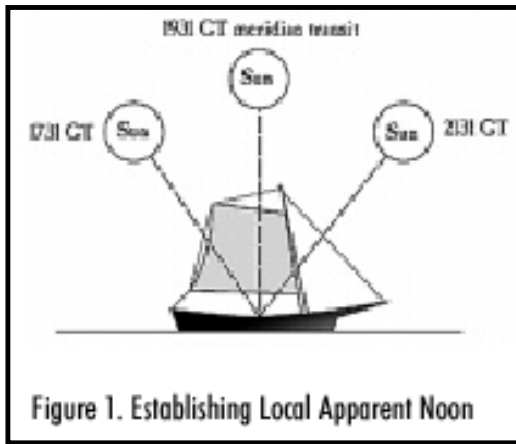

Figure 1. Establishing Local Apparent Noon

Add initial to final time of observation: 21hr. 31min. Greenwich time final observation 17hr. 31min. Greenwich time initial observation = 39hr. 02min.

Establish midpoint of observations for meridian transit: 39 hr. 02 min. /2 = 19 hr. 31 min. GT (Sun is on your meridian) Noon at Greenwich (0° longitude) from the tables was at 1204 1 / 2 . Subtract the Greenwich noon time from Greenwich time of the local noon yields 7 hr 26 1 / 2 min (use conversion factors above) convert the difference in time components to degrees and arc minutes and add them:

$15^\circ/\text{hr} \times (7 \text{ hrs.}) = 105^\circ$

$0.25^\circ/\text{min.} \times$

$(26 \frac{1}{2} \text{ min.}) = 6^\circ 38'$

Longitude = $111^\circ 38'$

W

How latitude is obtained by meridian transit of the Sun is shown in Figure 3.

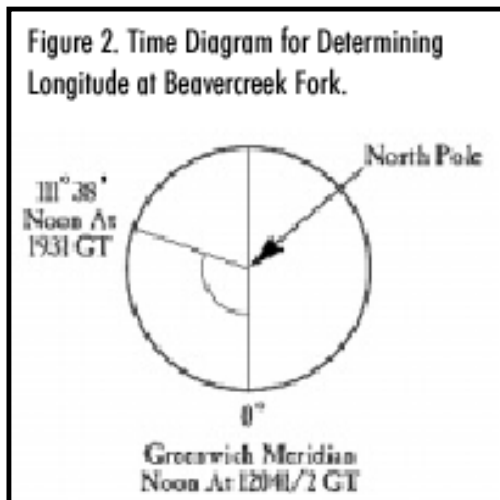

Figure 2. Time Diagram for Determining Longitude at Beavercreek Fork.

Steps in Obtaining Latitude

Lewis determines that at meridian transit of the Sun, its elevation was $60^\circ 02.4'$ (after corrections for refraction and semidiameter)

Latitude = $(90^\circ - h) + d$ Given declination "d" of Sun is $15^\circ 15.4' N$ $h = 60^\circ 02.4'$

Therefore Lewis finds his latitude as $45^\circ 13' N$ and longitude as $111^\circ 38' W$ In reality Lewis and Clark fully calculated longitude by lunar distances only once early in their journey up the Missouri River. It was left for the mathematicians at West Point to reduce the extensive data recorded on the expedition. So vexing was the task to reduce the data for longitude by lunar distances that F.R. Hassler, a West Point mathematics instructor, never succeeded in completing the calculations casting doubt as to whether Fort Catslop was located by lunar distances. If it were located with the fourmile accuracy claimed, it may have been achieved by meridian transit calculations. A lunar positions table (extracted from the British Almanac issued in 1766 for the year 1767) is shown in Figure 4. A diagram of the lunar distances spherical triangle showing the angles to be measured and the angle to be calculated is shown in Figure 5. The meticulous preparation for the expedition, the use of the finest available maps of the region, the creation of maps and charts en route and the recorded data made it possible for Lewis and Clark to accomplish their goal and preserve the Northwest region beyond the Louisiana Purchase for later claim by the United States.

Figure 4. Table of Lunar Positions

[36] MARCH 1767.		Distances of B's Center from ☉, and from Stars west of her.				
Days	Stars Names.	12 Hours.	15 Hours.	18 Hours.	21 Hours.	
		° / ' / "	° / ' / "	° / ' / "	° / ' / "	
3	The Sun.	47.35.32	49.14.7	50.52.15	52.29.58	
4		60.31.52	62.6.53	63.41.28	65.15.37	
5		72.59.57	74.31.33	76.2.45	77.33.33	
6		85.1.42	86.30.12	87.58.22	89.26.11	
7		96.40.30	98.6.26	99.32.5	100.57.27	
8		108.0.35	109.24.27	110.48.7	112.11.34	
9		119.6.21				
6		Arietis.	36.56.52	38.32.5	40.7.2	41.41.42
7			49.30.50	51.3.51	52.36.36	54.9.5
8	Aldebaran.	30.20.33	32.16.45	33.43.9	35.9.45	
9		42.24.35	43.51.40	45.18.45	46.45.51	
10		54.1.29	55.28.35	56.55.42	58.22.48	
11		65.38.23	67.5.29	68.32.35	69.59.42	
12	Pollux.	34.42.35	36.10.18	37.38.5	39.5.57	
13		46.26.22	47.54.39	49.23.0	50.51.26	
14	Regulus.	21.13.28	22.42.27	24.11.34	25.40.48	
15		33.8.32	34.38.25	36.8.24	37.38.30	
16		45.10.46	46.41.36	48.12.32	49.43.36	
17		57.20.54	58.52.45	60.24.45	61.56.54	
18	Spica.	15.48.39	17.20.38	18.52.46	20.25.17	
19		28.12.30	29.46.44	31.21.15	32.65.1	
20		40.53.41	42.30.0	44.6.34	45.43.27	
21		53.51.55	55.30.27	57.9.17	58.48.25	
22		67.8.48	68.49.50	70.31.11	72.12.52	
23	Antares.	34.55.40	36.39.31	38.23.42	40.8.14	
24		48.56.5	50.42.38	52.29.31	54.16.45	
25		63.17.49	65.6.58	66.56.24	68.46.7	
26	Capricorni.	23.43.43	25.32.9	27.21.11	29.10.44	
27	Aquila.	46.57.42	48.20.33	49.44.53	51.10.35	
28		58.36.8	60.7.55	61.40.21	63.13.19	

A slice of the Earth containing your meridian at the moment the Sun 'S' transits it

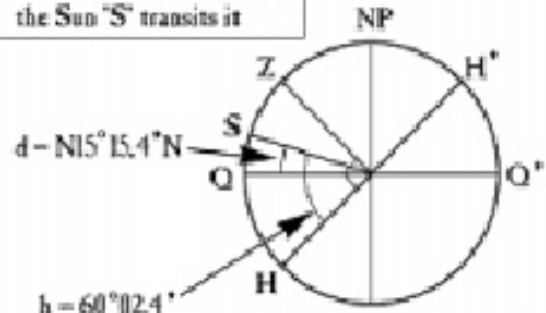

Figure 3. Latitude by meridian transit of the Sun. August 11, 1805, just south of Dillon, Montana at the fork of the Beaverhead River.

NP = North Pole
 Z = Zenith at your latitude
 arc QS = d = declination of Sun
 h = arc HS = altitude (elevation)
 arc ZS = zenith distance = $90^\circ - h$
 OQ' = equatorial plane
 HH' = horizon (90° from zenith)
 arc HZ = 90°

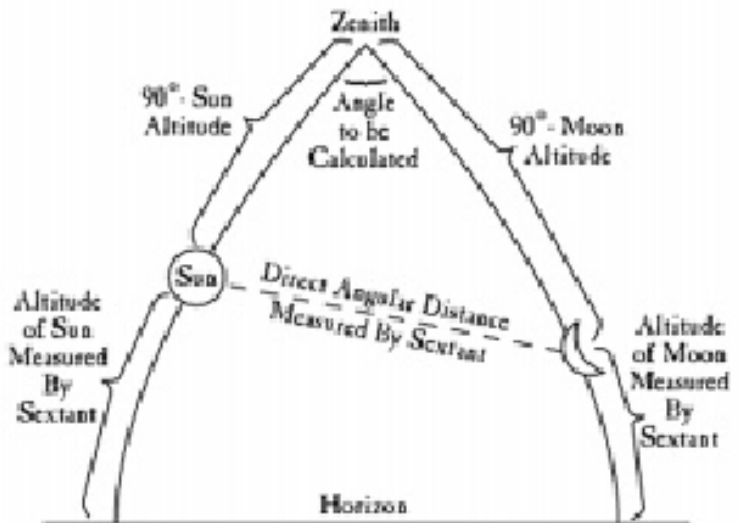

Figure 5. Lunar Distances Spherical Triangle

Afterword on Lunar Distances

Captain Vancouver (earlier a midshipman under Captain Cook), an experienced navigator, utilized lunar distances in establishing the longitude of Nootka a port on the west coast of Vancouver Island in 1792. He and his sailing master Lt. Whidbey made 13 sets of observations with an average difference from the mean value of 8.7 minutes of longitude (5.7 nmi at his latitude) and a standard deviation of the sets of 10.18 minutes of longitude. Each set was an average of from two to eight sets of lunar distances. The average number of observations in one set was 7.5. Since the scatter of a number of operations is reduced by the square root of the number of observations averaged, the standard deviation should be multiplied by the square root of 7.5 or 2.7. Therefore for a single lunar distance observation, the expected random error should have been about 30 minutes of longitude (19.5 nmi for latitude 49.5°). At sea

one could expect not to obtain better than one degree accuracy from a single lunar distances observation.

Bibliography

Duncan, Dayton and Ken Burns. *Lewis & Clark An Illustrated History*. New York: Alfred A. Knopf 1999.

Emmott, Norman W. "Captain Vancouver and the Lunar Distances." *Litton Avionics Newsletter*, Vol. One No. Three (March 1970): 2739.

Jones, Landon Y. *The Essential Lewis and Clark*. New York: The ECCO Press An Imprint of HarperCollins Publishers, 2000.

Calander

JUNE 2000

26-28:

IAIN (International Association of Institutes of Navigation) World Congress in association with the U.S. ION Annual Meeting;

Catamaran Hotel San Diego, CA, USA

Contact: ION,

Tel: 703-683-7101

Fax: 703-683-7105

www.ion.org

29:

Federal Radionavigation Plan (FRP)

Users Group Meeting;

Catamaran Hotel, San Diego, CA

Contact:

CarolAnn Courtney, DOT, Volpe

Conference Office

Tel: 617-494-2686

Fax: 617-494-2569

SEPTEMBER 2000

17-19:

Civil GPS Service Interface Committee (CGSIC),

Hilton Salt Lake City, Salt Lake City,

Utah

Contact:

Rebecca Casswell,

USCG Navigation Center

Tel: 703-313-5900,

Fax: 703-313-5920

Email: cgsic@smtp.navcen.uscg.mil

19-21:

The Satellite Division of the Institute of Navigation,
13th International Technical Meeting;
Salt Palace Convention
Center Salt Lake City, Utah, USA

Contact:

ION, Tel: 703-683-7101

Fax: 703-683-7105

www.ion.org

OCTOBER 2000

31-2 Nov:

The Future for Satellite Navigation;
Royal Institute of

Navigation Contact:

Tel: 44(0) 20 7-591-3130

Email: conference@rin.org.uk

NOVEMBER 2000

1315:

International Loran Association (ILA)
29th Annual Convention and Symposium;
Holiday Inn on the Hill, Washington, DC

Contact:

Tel: 805-967-8649

Fax: 805-967-8471

GPS The Next Generation GPS III and Modernization

Capping an ambitious modernization plan for GPS, the Department of Defense (DoD) is now seeking funds to begin studies for the next generation of GPS satellites, called GPS III, that would carry the global system into 2030 and beyond.

The current modernization program will add new military signals (Mcode) to Block IIR and IIF satellites, as well as new civil capabilities. That schedule now looks like this:

- *Last 12 Block IIR satellites: Add Mcode to L1 and L2 with increased power, add present civil C/A code to L2. First scheduled launch, 2003.*
- *First 12 Block IIF satellites: Add civil signal to third frequency, called L5, increase power. Add Mcode. Improve ground control system. First scheduled launch, in 2006 or later.*

Rather than exercising contract options with Boeing Corp. for up to 21 additional IIFs, and trying to negotiate modifications, the Air Force plans now to halt any further buys of IIFs. Instead, it has announced a decision to launch a new competition for a new generation of spacecraft, or GPS III, expected to cost more than \$1 billion. Military officials estimate this may be a cheaper and more effective way of adding spot beam capability and other modifications than trying to heavyup the remaining IIF satellites in the Boeing contract.

Although very much in the planning stage, the initial definition study for GPS III would be performed by the military's two Federal Funding Research & Development Centers (FFRDC), the MITER Corp. and the Aerospace Corp. The FFRDC's would develop data on such issues as realistic options, system capabilities, reasonable cost factors, etc., according to Pentagon managers familiar with the program.

Definitive Studies Needed

This phase would be followed by contracts, in FY2001, with three industry groups to conduct more definitive studies on requirements, system architecture, competitive trade issues, and other matters. Both civilian and military requirements would be solicited. Boeing, Lockheed Martin and several companies are expected to bid on this architecture study contract. DoD then sees a down selection to one contractor by 2003 for the design and production of the new series of GPS spacecraft.

Some preliminary information relevant to a new generation of satellites already exists in a draft Operations Requirement document prepared by the U.S. Space Command. Civilian input as now envisioned would come through coordination with the existing Interagency GPS Executive Board (IGEB), jointly chaired by Defense and the Department of Transportation.

Smart Weapons

Reprinted from Air Force Print News

Laserguided munitions came to prominence during the Gulf War when television screens across America showed the accuracy of the weapons. Iraqi bunkers, buildings and armored columns were routinely destroyed with unprecedented accuracy, helping make the Gulf War one of the most decisive military victories in global history. In the desert, only a sandstorm or, in some cases, the smoke created by burning targets nearby, would prevent the delivery of laserguided munitions.

Kosovo, on the other hand, reinforced the limitation that laserguided weapons systems are only effective if the target is not obscured. There, the poor weather and low visibility made laserguided munitions undeliverable or inaccurate and, in a handful of cases, dangerously so. Northrop Grumman's Joint Direct Attack Munition, a GPSguided munition, was instrumental in the campaign during Kosovo's consistently poor weather conditions.

"GPS guidance will still direct the munitions to target regardless of the weather," according to AF Col. Robert George, commander of the AF AirtoSurface Munitions Directorate. "If you lose your laser spot while the weapon is guiding, chances are you'll miss your target." A small number of GBU24, GBU27 and GBU28 laserguided bombs currently in the Air Force inventory will be upgraded, but the majority of the inventory of such weapons will be purchased from the manufacturer with GPS already installed.

"There were reports that we're doing GPS (modifications) on all our laserguided bombs," George said. "We're doing some, but we don't plan to retrofit the entire inventory."

While the conversion will end the laserguided munitions era and relegate the laser guidance system to secondary status, according to George, contrary to published reports, the GPS conversion doesn't mean that the Air Force's inventory of laserguided weaponry will be mothballed or no longer used in future warfare. It merely gives Air Force pilots options and flexibility.

"The GPS will guide the weapon to within a few meters. Add laser guidance to that, and, in theory, you should be able to guide it through an open window," George said.



Can We Share?

GPS Spectrum Issues

Pending Before WRC

By Lawrence Chesto

A number of important issues affecting the Global Positioning System are before the World Radiocommunication Conference 2000 (WRC2000), which began May 8 in Istanbul, Turkey, and runs to June 2. The outcome of the conference will be revised International Telecommunication Union (ITU) Radio Regulations (RR). GPS related issues for WRC2000 are listed below and are addressed by their related agenda item. GPS operates under the RR allocation of radionavigation satellite (RNSS). A Conference Preparatory Meeting (CPM) was held in November 1999 and its report addresses the technical, operational and regulatory/ procedural matters to be considered by WRC2000.

GNSS and Fixed Service (FS)

Agenda items 1.1 (deletion of country footnotes to the RR) and 1.15.3 (status of allocations to services other than the RNSS) are related because RR country footnotes S5.355 and S5.359 exist in the 1559-1610 MHz band where RNSS is allocated. S5.355 allows FS to operate on a secondary basis in 25 countries in the 1540-1645.5 MHz and 1646.5-1660 MHz bands. S5.359 allows FS to operate in 44 other countries in the 1550-1645.5 MHz and 1646.5-1660 MHz frequency bands.

Studies have shown that FS stations can cause harmful interference in large areas to GPS operations because of their high power (up to 39 dBW) and wide bandwidth of several MHz. The CPM report stated that "On the basis of these studies, it is concluded that RNSS receivers would be unable to support cofrequency interference from FS transmissions within radio line of sight." It was also noted that "FS stations registered in the ITU MIFR with higher power and greater bandwidths were not considered in the current studies." The CPM also stated, "In order to protect present and future RNSS applications, sharing of the band 1559-1610 MHz between RNSS and FS is not recommended."

Only those countries that are listed in the footnotes can remove themselves from the footnotes. Removal of these footnotes in the 1559-1610 MHz band is required for GPS operations to exist without potential harmful interference within or near these countries when an FS station is in operation in the RNSS band.

GPS, and Mobile Satellite Service (MSS)

Agenda item 1.9 (feasibility of an allocation to MSS in a portion of the 1559-1667 MHz band) addresses the need for more spectrum for MSS in the 1559-1667 MHz band. The issue is can a MSS allocation exist with an RNSS allocation in the 1559-1610 MHz band. There are some that think that sharing with GPS is possible at a certain power flux density but there is no agreement what this power flux density should be. The CPM stated, "It is therefore concluded that sharing between ARNS/RNSS and MSS (space to Earth) is not feasible in any portion of the 1559-1667 MHz band." It is important that no allocation to MSS in the RR be made at WRC2000 in order to protect current and future RNSS operations as there is no way to have MSS meet the stringent RNSS safety requirements (e.g., control of power flux density to ensure no harmful interference).

New Allocations for RNSS

Agenda item 1.15.1 (consider new RNSS allocations in the 1 to 6 GHz band) addresses several potentially new radio frequency bands for the addition of an allocation to RNSS to support new navigation services such as the GPS L5 signal at 1176.45 MHz and other new RNSS systems. The CPM report addresses the 960-1215 MHz, 1260-1300 MHz, 1300-1350 MHz, 5000-5030 MHz and 5091-5150 MHz bands as a potential for new RNSS allocations. The critical band for the new GPS L5 (1176.45 MHz \pm 12 MHz) signal is the 960-1215 MHz band.

The 960-1215 MHz band is currently allocated to the aeronautical radionavigation service (ARNS) on an exclusive, worldwide basis. It is used for ICAO standardized radionavigation and surveillance systems that include the Secondary Surveillance Radar (SSR), the Airborne Collision Avoidance System (ACAS) and the Distance Measuring Equipment system (DME) and is also used for the Tactical Air Navigation system (TACAN). A portion of the band is used by ground DME and TACAN transponders.

The CPM study concluded that RNSS signals could be designed so they do not cause interference to ARNS receivers. However, ARNS transmitters can cause harmful interference to RNSS receivers. Radar systems in the 1215-1400 MHz band are also a potential problem. Several potential solutions to these problems have been investigated including design of the RNSS receiver, reassignment of certain

DME/TACAN frequencies, and use of a dualbandwidth RNSS signal. Interference to RNSS receivers at high altitudes can be reduced by use of a RNSS narrowband signal component and at lower altitudes, use of a wideband signal component can be used for precision applications.

The CPM report stated “It was recognized that, if an allocation to RNSS were to be made in any part of the band 9601215 MHz, further study effort will be required by ITU, ICAO and others to develop recommendations to ensure compatibility between the various systems in the band.”

SpacetoSpace Operations

Agenda item 1.15.2 (addition of RNSS spaceto space direction allocations) addresses new RNSS allocations for spacetospace operations in the 1215–1260 MHz and 1559–1610 MHz bands. This service is being used on satellites and spacecraft for navigation and other related uses. While the CPM text supports an allocation to RNSS spacetospace direction in these bands there are several options that could restrict the amount of protection this new allocation would receive at WRC2000. It is important that an allocation is made for spacetospace RNSS and that any footnotes that limit protection should not be approved at WRC2000.

The CPM report addressed three options. All options propose the addition of an allocation to RNSS, spacetospace direction, in the 12151260 MHz and 15591610 MHz bands with a provision indicating that no protection should be given to spaceborne RNSS receivers from RNSS systems already operating in these bands or for which complete advance publication information has been received prior to the end of WRC2000.

The first option is as above. The second option includes the statement that spaceborne receivers operating in the 15591610 MHz band should not request protection from unwanted emissions of stations of the MSS (Earthospace) operating in the band 16101660.5 MHz. The third option includes an additional statement that spaceborne RNSS receivers should be deployed and operated in a manner that they either avoid or accept possible interference at levels equivalent to those caused by current MSS (spacetoEarth) systems in the bands 15251559 MHz or those for which a request for coordination has been received prior to the end of WRC2000.

Summary of WRC2000 Potential Impact on GPS

WRC2000 will make changes to the RR and is not required to adhere to CPM recommendations. Decisions at the WRC are based more on political and economic issues than on technical and operational considerations.

Country footnotes for FS are a potential problem for worldwide GPS operations. Harmful interference will most likely be caused to GPS operations within radio lineofsight of FS stations operating at or near the GPS frequency. Some countries have changed their frequency assignments to avoid harmful interference to GPS operations. All countries should do this as a minimum.

An allocation to the MSS in the 1559–1567 MHz band could lead to harmful interference to current GNSS receivers and restrict new applications of GNSS in the 1559–1610 MHz band. An allocation to MSS must be avoided to ensure protection of GPS safety operations.

The GPS L5 (1176.45 MHz) frequency (including sufficient bandwidth) needs to be protected by a RNSS allocation. Failure to obtain the RNSS allocation means no international protection for this GPS L5 signal and thus can limit worldwide operational use. Spacetospace RNSS allocations are essential to protect the many new applications now being implemented for GPS receivers on satellites and other spacecraft. The spacetospace allocation should not have too many restrictions or there will be little protection achieved with a new allocation.

—Lawrence Chesto is an aviation consultant. He is chairman of RTCA Special Committee 159 on GPS standards for aviation. He also is an advisor to the U.S. representative of ICAO’s GNSSP.

FCC Releases NPRM on Ultra-Wideband Technology —

Concerns Over Potential Interference To GPS and Other Systems

The Federal Communications Commission released on May 11, 2000, the Notice of Proposed Rule-Making (NPRM) on the Ultra-wideband technology. The FCC has proposed "...permitting the operation of ultra-wideband (UWB) technology on an unlicensed basis" citing "...enormous benefits for public safety, consumers and business" (FCC Press Release).

Concerns of the potential for GPS interference as well as interference to other aviation systems have been raised. Once the NPRM is published in the Federal Register, comments will be due to the FCC within 90 days, followed by a reply comment period of 30 days. The FCC has stated that test results can be submitted up to October 30, 2000. Current testing efforts either being shaped up or underway include a DOT-sponsored testing being conducted at Stanford University, a Time Domain sponsored test at the University of Texas and a testing effort being shaped up by

the National Telecommunications and Information Administration (NTIA). These plans will be briefed at the upcoming meeting of the RTCA Working Group 6 on June 13th in Washington, DC (202) 833-9339.

*The press release can be obtained at:
http://www.fcc.gov/Bureaus/Engineering_Technology/News_Releases/2000/nret0006.htm*

*The NPRM text can be obtained from:
http://www.fcc.gov/Bureaus/Engineering_Technology/Notices/2000/fcc00163.doc.*

Comments to the FCC can be electronically filed through their website (see <http://www.fcc.gov/e-file>). This NPRM is ET Docket 98-153 under the Office of Engineering and Technology with point of contact Mr. John Reed at (202) 418-2455.



The Fourth User Domain GPS Space Use Evolving *By John Rush*

Terrestrial, maritime, and aviation uses of GPS are all well known. However, space is a fourth user domain that has quietly developed over the past few years and is rapidly moving from research to every day application. More and more satellites are being launched that use GPS in a variety of applications. The Figure 1 chart was developed from data collected by Dr. George Davis, Orbital Sciences Corporation, for the Goddard Space Flight Center and it depicts the dramatic increase in the number of satellites launched each year with GPS receivers onboard. A major reason for the increase in recent years has been the introduction of GPS receivers onboard operational commercial satellites.

For the most part, current applications involve position determination and spacecraft time synchronization for satellites in Low Earth Orbit (LEO). In some applications GPS is also used to determine spacecraft attitude (orientation about its axis) as a backup to the sensors traditionally used for this purpose.

Although many of these applications are experimental, there are some instances where GPS is being used in critical spacecraft operations. As we gain more experience with its use aboard satellites and become more confident in its reliability, GPS may become the standard way of accomplishing the satellite tracking function that has been traditionally done using ground communication antennas. The maturity of GPS use on satellites for the tracking function has the potential of reducing operational costs, and can provide more precise positioning information than is typically available through the use of ground antennas. But, perhaps most importantly, satellitebased GPS use is an enabling technology that will lead to the ability to operate satellites more autonomously and enable new capabilities.

A few examples of what satellitebased GPS use can enable in the future.

- *Satellites that maintain their own orbits as ordered with a few simple commands from ground controllers: Today we have to provide tracking information from ground antennas and build detailed commands to adjust and maintain satellite orbits. In the future a GPS receiver combined with onboard orbit determination software and a closed loop propulsion system will be able to autonomously maintain the desired orbit. The commanding needed to do this will be simple descriptions of the desired orbit.*
- *Formation flying of small satellites clusters through the use of differential GPS: Groups of small satellites will be able to conduct coordinated Earth observations while maintaining precise relative location with respect to each other. The satellites in a cluster will be able to work together implementing coordinated observations, for example, enabling new levels of stereoscopic imaging. This same relative navigation technique will be of benefit in future space operations involving orbital rendezvous of autonomous vehicles bringing supplies to the International Space Station or in other autonomous Earth orbit rendezvous operations.*
- *GPS receivers onboard satellites can double as a science instrument: Two applications in particular that show great promise are the use of GPS signals to investigate atmospheric composition, and the use of GPS signals reflected off of the ocean surface to determine sea state. In the first application dual frequency signals are observed for GPS satellites that are low on the horizon such that their signals are partially occulted by the Earth's atmosphere. Measuring the relative distortion in the signal path can provide information concerning the density of the atmosphere at various altitudes which can further be related to atmospheric conditions such as water vapor content. In the second application very weak GPS signals would be detected by GPS antennas that look toward the Earth. Scatter measured in the reflected signal would be a function of the roughness of the water surface. The above examples are just a few instances where GPS may be used to advance the stateoftheart in satellite capabilities and operations. All of the above examples are being actively pursued today in research and development efforts at NASA and international space agencies around the world. But there are a few recent and future events and initiatives of note that will have a significant bearing on GPS space users:*

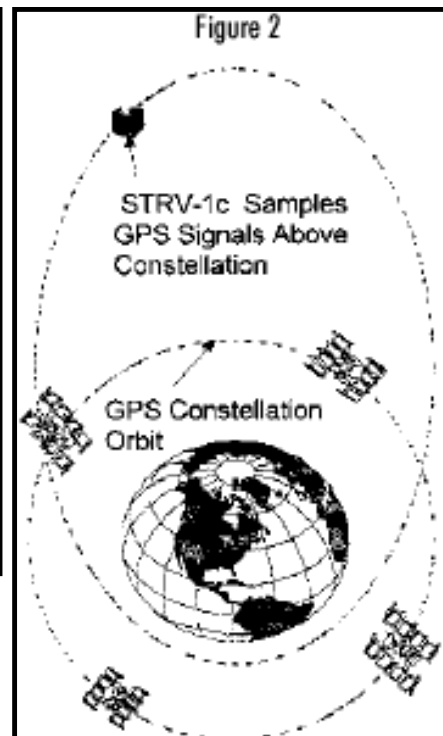
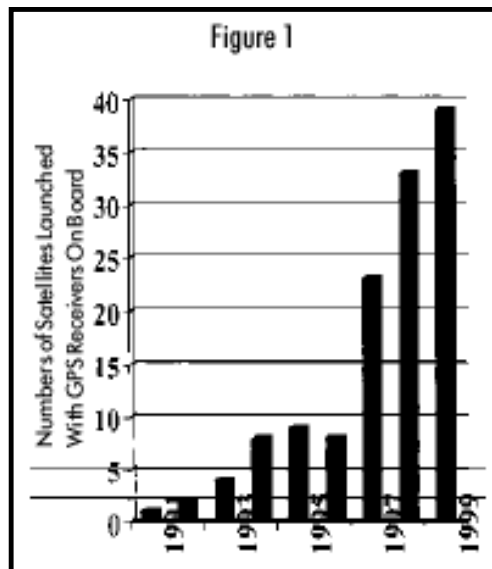

Elimination of Selective Availability

Of course, the recent termination of Selective Availability provided greatly improved precision potential for single frequency space users of GPS. Estimates from the Goddard Space Flight Center indicate that the improvement will allow about 50m in instantaneous orbit positioning precision for a satellite in a 450 km orbit, and about 10m for a satellite in a 700 km high orbit. This is down from about 100m. The difference in the level of precision estimate between the two is attributable to the greater amount of signal distortion encountered by the lower satellite due to the ionosphere.

GPS Modernization

The next major enhancement for space users will come from the GPS Modernization program. Many LEO satellites operate in a region where they encounter ionospheric distortion. The addition of the second civil signal to GPS satellites beginning in 2003 will be a major step toward improving GPS precision in the use of GPS for satellite positioning. With the second civil signal at L2 being broadcast with the same C/A code as on the L1 signal, dual frequency spaceborne receivers that correct for ionospheric distortion can be provided at little added cost.

Expanding the Space User's Envelope — Higher and Higher

As mentioned earlier, space use of GPS today is pretty much limited to Low Earth Orbit. However, there is research ongoing to determine the degree to which GPS can be used by satellites in orbits near and above the GPS constellation. Two early experiments, the EquatorS and FalconGold missions, confirmed that GPS signals can be detected above the GPS constellation. Shortly a number of new experiments will be conducted using satellites in highly elliptical orbits with apogees above the GPS satellite orbits. These experiments will measure the characteristics of the signal near and above the constellation. One such experiment will be the GPS At Geostationary Transfer Orbit Experiment (GAGE). GAGE is a jointly sponsored NASA / GPS JPO / British Defence Research Agency (DERA) experiment that will carry a NASA / JPL BitGrabber GPS receiver into a highly elliptical orbit aboard the British Space Technology Research Vehicle (STRV) 1c. The mission is presently scheduled to be launched in October of this year aboard an Ariane.

Onboard the same launcher will be an amateur radio satellite with a GPS receiver supplied by Goddard Space Flight Center that will enter a similar orbit and conduct a similar experiment. Between the two experiments and together with data already collected from EquatorS and FalconGold, we will be able to better understand the GPS signal characteristics at higher orbit altitudes in order to build GPS receiver systems that will be able to extend the benefits of GPS out to Geostationary Orbits around 20,000 km above the GPS constellation.

Regulatory Protection — The SpacetoSpace Allocation Initiative

Fundamental to the use of GPS onboard satellites is the confidence that the GPS signals can be received free of interference from other radio emissions. The first step in assuring this level of confidence is being addressed in the next few days at the World Radio Conference 2000 (WRC00) in Istanbul, Turkey. In addition to other key considerations affecting surface and aviation GPS users, the Conference will be considering whether to grant a global radio spectrum allocation in the spacetospace direction to protect spaceborne users of radionavigation signals in the bands 1215 – 1260 and 1559 – 1610 MHz. These bands include the GPS L1 and L2 bands. Currently the international allocation only protects the use of GPS signals in a spacetoEarth direction, meaning that spacecraft using GPS have no regulatory protection.

The proposed spacetospace allocation was brought forward at WRC97 where it was put on the agenda for the next Conference (WRC00). It was directed that the proposal undergo technical studies to assure compatibility with the existing electromagnetic environment. During the past two years an NTIAled technical study team has conducted numerous studies on space use compatibility of GPS that have been presented at international study group meetings preparing for WRC00. All of these studies have demonstrated space use compatibility with other uses of the spectrum. At the time of writing we know of no major issues that should stand in the way of achieving the allocation.

During the coming years it is anticipated that the use of GPS aboard Earth orbiting satellites will move from the research to the operational stages in a number of different application areas. As discussed above, many of these applications go well beyond navigation alone and many hold the promise of enabling new ways of doing business in space.

—*John Rush*

NASA Headquarters, Space Navigation and Communications System Architect.



IN MEMORIAM

Dr. Leonard Kruczynski, a member of the ION Council and program chair for the ION GPS '97 conference, died of pneumonia at Stanford Hospital on May 11, after an earlier bone marrow transplant for leukemia failed. Len was director of strategic relationships at Ashtech and previously worked for Trimble. He retired from the U.S. Air Force as commander of the GPS Test Force in Yuma, Ariz. He held a B.S. from the Air Force Academy, an M.S. from Purdue, a Ph.D. from the University of Texas at Austin, and an M.B.S. from Santa Clara University.



ION STUDENT AWARD

Cadet Michael Vincent Danish, U.S. Coast Guard Academy, received the ION award to academy graduates for outstanding work in navigation. The annual ION award and cash prize were presented by current Eastern Council Member-at-Large, Capt. James T. Doherty, to Danish, now Ensign Danish, during graduation ceremonies in May.

Satellite Division News

Satellite Division Nominations

Nominations were submitted by the 2000 Nominating Committee for officers of the Institute of Navigation's Satellite Division. The Satellite Division's Nominations Committee was chaired by Mr. Gaylord Green.

Pursuant to Article V of The Institute of Navigation Satellite Division Bylaws, "additional nominations may be made by petition,

signed by at least 25 members entitled to vote for the office for which the candidate is nominated.”

All additional nominees must fulfill nomination requirements as indicated in the ION Satellite Division Bylaws and the nomination must be received at the ION National Office **by June 26, 2000.**

Ballots will be mailed in July. Election results will be announced during the 13th International Technical Meeting of the Satellite Division of the ION, being held Sept. 19–22, 2000, in Salt Lake City, Utah.

The newly elected officers will take office on Sept. 22, 2000, at the conclusion of the ION GPS Meeting and will serve for two years. Election results will be reported in the ION Newsletter.

Kepler Award Nominations

The Satellite Division is seeking nominations for the esteemed Johannes Kepler Award. The Award will be presented Sept. 22, in Salt Lake City at the ION GPS 2000 Awards ceremony.

The winner of the Award is determined by a special nominating committee. The primary purpose of the award is to honor an individual for sustained and significant contributions to the development of satellite navigation. All members of the ION are eligible for nomination, but the award is bestowed only when deemed appropriate.

Individuals are encouraged to submit names for consideration. Please provide a supporting letter to Dr. Jim Spilker, Satellite Division Awards Committee chair. Fax to 1 7036837105, or email: membership@ion.org before Aug. 1, 2000.

Prior Kepler Award Winners:

1999: Dr. James J. Spilker, Jr.

1998: Dr. Peter Daly

1997: Dr. Gerard Lachapelle

1996: Dr. Frank van Graas

1995: Dr. Richard J. Anderle

1994: Ron Hatch

1993: Dr. A.J. Van Dierendonck

1992: Dr. Rudy Kalafus

1991: Dr. Bradford Parkinson

Parkinson Honored

The University of Calgary, Alberta, Canada, is awarding Dr. Bradford Parkinson an Honorary Degree at its Convocation June 16 in honor of the recipient's leadership as program director, 1973 - 78, while a Colonel in the U.S. Air Force, of the GPS program. Parkinson presently is a professor in the Department of Aeronautics and Astronautics, Stanford University.

Section News

GREATER PHILADELPHIA SECTION.

Bylaws were adopted and a slate of officers submitted at an organizational meeting to revitalize the dormant section at Penn State University (PSU) facilities on April 24. The following officers and chairpersons were designated: Marvin B. May, ARL/PSU, chair;

John Warburton, FAA, vice chair; Ray Filler, CECOM, secretary, and Victor Wulschleger, FAA, treasurer. Chairpersons included Victor Wulschleger, FAA, special activities; Phil Holmer, FAA, programs; John Phanos, Galaxy Scientific, membership; Lou Naglak, NAVMAR, corporate affairs, and Neil Weinman, ARL/PSU, student awards.

NEW ENGLAND SECTION

The Section's 15th meeting was held at the Volpe Center on March 29th and featured a presentation on the Joint Precision Approach and Landing System (JPALS) by Maj. Dan Uribe of the GATO/MC2 Program Office at ESC, Hanscom AFB. Also short presentations were given by Ilir Progrid (graduate student at WPI) on an Evaluation of CATIII Landing with Pseudolites and Bette Winer of MITRE on an overview of MITRE activities in the navigation area.

Third Block IIR GPS Satellite Orbiting

After a three-week launch delay, the third in the Block IIR series of GPS satellites lifted into space aboard a Delta II rocket from Cape Kennedy at 9:48 p.m. on May 10.

The \$42 million satellite, built by Lockheed Martin (LM), replaces one in the constellation launched 11 years ago. LM has a contract to supply 17 more Block IIRs over the next five years. Pending approval of funding by Congress, LM will be tasked to make further improvements in the last 12 Block IIRs, including additional military and civilian signals, increased power and other 'modernization' enhancements.

The Delta series of rockets, now made by Boeing, have racked up a record for launching 31 GPS spacecraft, including the most recent. Boeing has a launch contract on Delta IIs for the next 17 Block IIRs. It also is producing the next generation of GPS satellites, the



The next launch of a IIR is scheduled for the morning of June 21.



The next launch of a IIR is scheduled for the morning of June 21.

Block IIFs, which are to be launched on the new Boeing Delta IV rockets that are part of the Air Force's Evolved Expendable Launch Vehicle (EELV) program.

Global Marketing of GPSBased Aviation Services

With the acquisition of Comsat Corp., Lockheed Martin seeks to strengthen its bid to operate a global satellite system for aviation navigation and offer a full range of WAAS and LAASlike services.

The acquisition of Comsat, largest owner of the global Intelsat and Inmarsat satellite communications networks, is expected to be completed later this summer. Comsat currently leases capacity on two Inmarsat satellites to the FAA for WAAS broadcasts; it recently signed a five year extension of that contract. A LM spokesman said the price is about \$2.4 million per year per satellite.

A new company called Synchronetics, formed by LM, is taking over, and expanding, the company's range of navigation services offerings. Part of the services include the Regional Positioning System (RPS), a plan announced by LM in June of last year to own and operate three geosynchronous satellites to broadcast GPS augmented signals for improved accuracy and integrity. An application for this system is pending before the FCC.

Mating With Ground Segment

Beyond that, Synchronetics is now seeking partners to supply the ground segments for both WAAS and LAASlike systems to countries in Latin America and elsewhere that lack ground augmentation networks. "We're looking for partners for the both the ground and the space segments," explains Daniel Brophy, director of navigation services for LM air traffic control management.

Synchronetics is forming three regional subsidiaries to provide seamless satellite coverage worldwide: the Americas, AsiaPacific and EuropeMiddle East Africa. Each region is to secure separate financing and seek inregion partners to develop the system.

"This structure provides regional participation and control," LM declares in a March 20 statement, "while capturing the efficiencies of a single global architecture and facilitating a single standard for user equipment."

LM says the space system will be compatible with the U.S. WAAS and LAAS and the European EGNOS. Capital costs for a dedicated threesatellite global system are about \$450 million for the space segment, Brophy estimated.

WRC Interest

LM is trying to line up partners, find internal financing, push its application for a dedicated system (not one hosted on other communications satellites) through the FCC, work with Honeywell in building a technical competence in ground segment engineering, all the while keeping an eye on proceedings at the World Radionavigation Conference in Istanbul. It is backing vigorously the U.S. effort to designate frequencies for the GPS L5 carrier.



From the Editor **What a Difference A** **Day Makes**

The White House reports that more than 700 U.S. households connect for the first time to the Internet every hour. They are part of the legends joining the rush to the wired world: “More than half of all American households now use the Internet,” according to the White House statement. “More than half of U.S. classrooms are connected to the Internet today, compared to less than 3 percent in 1993.”

The above examples served to buttress President Clinton’s budget requests for record federal spending in FY2001 on science and technology. Overall, the Administration is asking for a whopping \$43 billion in Research & Development (R&D) across all agencies, including Defense, up \$2.8 billion over the previous year. Federally funded basic research tangentially benefits the sciences of navigation/ positioning and timing.

The proposals are now before Congress. Changes in the Administration’s requests are inevitable, but science and technology generally enjoy the bipartisan support of both Republicans and Democrats.

The Administration repeated the supporting theme that R&D programs form the bedrock of America’s prosperity in the 21st century. Even Alan Greenspan — the world listens when the Federal Reserve Board chairman speaks — said at one time that 70 percent of the U.S. economic boom is due to technological progress.

One of the biggest beneficiaries of the Administration’s R&D largess is the National Science Foundation (NSF). The NSF budget would rise to \$4.6 billion, a proposed 17 percent increase and the largest oneyear dollar increase in its history. Although the NSF accounts for a small portion of overall government R&D spending, it supports about 50 percent of all basic research in science and engineering disciplines (nonmedical fields) at universities and colleges.

Among all the science budget initiatives, perhaps one with an obvious impact on navigation/positioning is new proposed information technology (IT) programs. Like GPS, IT delivers tools and capabilities that benefit almost every R&D effort. An example: research to ensure that mobile and wireless systems can be integral parts of the Internet. These inventions will permit devices embedded in equipment or vehicles such as GPS receivers, or even wearable devices such as navigation boxes for the blind, that identify themselves to networks automatically and operate with appropriate levels of privacy and security.

The column in the previous issue of this Newsletter applauded the Air Force’s Independent Review Team (IRT) for its work in establishing the new GPS L2 and L5 civil codes/signals. It was not meant to give the IRT undue weight, or ignore other contributors. Brian Mahoney, FAA, reminds us in a note that the RTCA made critical inputs in defining the L5 signal. He mentions the work of RTCA SC159, chaired by Larry Chesto. Specifically the work done by A.J. Van Dierendonck and Chris Hegarty on the L5 Working Group within SC159 in “establishing the baseline and trying to find an equitable solution to the coexistence of L5 with the FAA’s DME and DoD’s JTIDs systems.” From the ION standpoint, we’ll add Keith McDonald who early helped stage conferences and ION working groups to identify and define civil improvements.

To others, so many others in industry and government, too numerous to mention here, who contributed to the GPS modernization package, the nation thanks you.

[Close Window / Return to ION Website](#)

Return to
The Expedition

HOME

Return to
MAP OF THE TRAIL



Page 4 of 7

Formal Navigation by Lewis & Clark



uch of what Lewis and Clark had to do in terms of their own mapmaking was to ascertain the accuracy of Indian information by doing what we call today "ground truthing"—checking Indian data against their own visual observations—and "celestial

reckoning," using the instruments they carried for the purpose of fulfilling Jefferson's instructions to "take [careful] observations of latitude & longitude." To fulfill these tasks they used instruments: spirit and telescopic levels, several compasses including a surveyor's compass

or circumferentor with extra needles and even a magnet to "polarize" them, a sextant, a "Hadley's quadrant" or octant, rods and chains, telescopes, artificial horizons, drafting instruments, a very early version of a measuring tape, and a clock or chronometer. They also used books and tables giving the daily locations of sun, moon, and planets for use in computing geographical position after obtaining sightings of these "celestial objects." The two most important groups of items of the Lewis and Clark Expedition, if cost is the measure, were mapping instruments and gifts for native peoples: these were the tools of empire, necessary in establishing a claim to place and space and defending that claim through trade

Both Lewis and Clark were reasonably proficient in the use of these instruments and for 28 months, as long as the Expedition was on the move, a part of the daily routine was the measurement of latitude and longitude and the calculation of course, time, and distance of

travel. Even during those times when Lewis and Clark were fixed in location for lengthy periods of time, such as at Fort Mandan and Fort Clatsop, the "mathematical instruments" saw almost daily use, weather permitting.

**Global Positioning
System**

In this, the captains followed Jefferson's instructions to the letter and throughout the Expedition made the two basic types of geographical observations their sponsor had requested: (1) daily measurements of local features, taken continually during a day's travel; and (2) the more abstract measurements of latitude and longitudinal position, usually made by astronomical observation when and where atmospheric conditions allowed, but most commonly at camp during the night. Their guides were the moon and the stars.

Those Cryptic Journal Entries

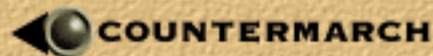

From [Discovering Lewis & Clark®](#), © 1999 VIAs, Inc.

Return to
The Expedition

HOME

Return to
MAP OF THE TRAIL



Mapping
Terrae
Incognitae

Page 5 of 7

Those Cryptic Journal Entries:

Course... Time... Distance... Remarks

By far the most common observations were the daily measurements that are found in the journals of Lewis and Clark as "Course...Time...Distance...Remarks. & returns". These were intended to be used as the early 19th century equivalent of the guide book from AAA, that tells you how to get from place to place, what sights you're going to see on the way, where to lay up at night, and where to get a good chicken-fried steak.

Course referred to the direction the expedition was traveling, stated as a compass bearing between two points. To obtain this bearing, or "azimuth," the captains used one of the pocket compasses or else the larger surveyor's compass (circumferentor) to get direction from one reference point to another—from the point of a bluff along the Missouri's north side, for example, to the tip of a prominent sandbar on the south side of the river (reference points were always identified in the journals). Their compasses registered magnetic north rather than geographic north and their readings had to be adjusted for the difference or "declination." They understood the errors that would creep in as they moved from east to west across the continent and continually adjusted the declination of their compasses to insure accuracy of readings.





Time, stated in hours and minutes, was the time required to get from the reference point used to establish the beginning of a course azimuth to the reference point marking the end of that particular compass bearing. Time was established precisely by chronometer—as long as the captains remembered to keep it wound. Because they did forget to wind it regularly there were frequent occasions when travel time was an estimate. But living as close as they did to the natural world, while still having a temporal frame of reference that included hours and minutes and seconds,

reasonably accurate time estimates would have been less of a problem for them than for the native peoples who possessed few or no short-term time concepts, or for us latter-day folks who are not only more divorced from nature but have relied for so long on the watches strapped to our wrists that we find it difficult to evaluate time any other way. Still, most of the temporal observations of Lewis and Clark were obtained by timepiece—the chronometer that cost more than all the rest of their "mathematical instruments" combined.



Distance was expressed between the same two points used to derive course and time. This was normally given in miles but occasionally in yards or rods. These measurements were obtained either by pacing a course between two points or by [estimating distances](#). Estimations are relatively easy for people having long familiarity with their environment, their own travel paces and their mode of transport. They walked about as often as they rode and this allowed them to judge both time and distances much more accurately than we can while driving a car at speeds that may vary widely (from 15 miles per hour in a school zone to 75 mph on an interstate highway).

Their sense of time and distance was more precise than ours because their survival so often depended on it and because they moved across the landscape in very different ways than we do. Throughout the expedition, the captains were reasonably accurate in their measurement of distance. They accomplished this with good guesswork, enlisted men to do the grunt work of pacing out courses, fairly sophisticated instruments and mathematical calculations, and careful attention to detail.

Remarks or reference observations were comments on the widths of the Missouri and the creeks and smaller rivers that entered it, the heights of bluffs or hills along the river, and—most common and most important—the identification of the reference points upon which the compass bearing/distance/direction information was based. Jefferson's directive to Lewis had included the order to note "all remarkeable points on the river, & especially at the mouths of rivers, at rapids, at islands, & other places & objects distinguished by such



Starboard?
Larboard?

natural marks & characters of a durable kind, as that they may with certainty be recognised hereafter" and the captains were faithful to these instructions.

Careful Observations



From [Discovering Lewis & Clark](#)®, © 1999 VIAs, Inc.

Return to
The Expedition

HOME

Return to
MAP OF THE TRAIL



Page 6 of 7

Careful Observations

... you will take [careful] observations of latitude & longitude

—Thomas Jefferson, *Instructions to Meriwether Lewis*, 20 June 1803

Thomas Jefferson was as interested in the methods and equipment for "ascertaining by celestial observation the geography of the country" as with any other single aspect of the Expedition. He played an important role in making sure that Lewis purchased the proper equipment and learned how to use it before he left for the West. He also insisted that observations be conducted with accuracy, would be redundant, would be comprehensible to others, and that sufficient copies of all observations would be made to guarantee against the possible loss of one or more sets. As faithfully as they could, the captains complied with the President's wishes.

Latitude. For Lewis and Clark, as for so many of their predecessors and contemporaries, calculating latitude was far simpler than calculating longitude. In the northern hemisphere, latitude may be derived by measuring the angle made between the North Star and the horizon. Crude instruments to obtain this angle have existed for thousands of years and by the time of Lewis and Clark, instruments like the sextant and octant, only slightly less precise than those available to us, were in use.

Latitude may also be calculated by measuring the altitude of the sun, moon, or certain planets and stars above the horizon on known days and reading latitude from tables designed for that

purpose. It was not much more difficult for the captains to measure these altitudes with a sextant or octant and to calculate latitude using one of the three *ephemeræ* or astronomical almanacs they carried. These contained tables showing the daily position of celestial bodies such as the sun, the moon, and key stars.

Calculating latitude gave Lewis and Clark few problems and their readings were accurate to within a fraction of a degree.

Measurement Errors

Longitude. Longitude can be calculated using either time or astronomical observation. Calculating longitude by chronometer is based on the fact that any point on the earth's surface moves through a complete circle of 360 degrees once in a 24-hour period; during 1 hour, any point on the earth's surface moves through an east-to-west 15° arc of a full circle. If time can be fixed along any meridian of longitude, then longitudinal distance can be determined by comparing time at that meridian with local time, usually based on the point at which the sun reaches its zenith.



All this seems quite simple. Why, then, were the captain's longitudinal observations so prone to error? The answer is also simple: their chronometer did not have, as ours do, a quartz battery to keep it running. When it ran down, it had to be re-calibrated using local time: using observation of the sun's zenith or local "noon" and then setting the chronometer by estimating the Expedition's current longitudinal position. Over the course of the expedition, the small incremental errors produced by this became larger ones.

Determining Longitude

There were other methods of calculating longitude available to them, using astronomical observation. But many astronomical readings had to be acquired over the course of a night in order to obtain sufficiently precise data to determine longitude. It was asking a lot for men exhausted by the rigors of their daily trek, to spend three or four hours in the cold and damp of a mountain night taking sightings of the moon and stars, recording observations, and making calculations by firelight. It was only natural that errors would exist in data obtained in this manner. Even the most skilled astronomer or surveyor would have been hard pressed to make highly accurate observations under such circumstances.

Clark's Map 

 **COUNTERMARCH**

From [Discovering Lewis & Clark®](#), © 1999 VIAs, Inc.

< ɹWkoÛ: ý^ ÿa@Šmw ĺ Ò<šÛØ¾pl'qo“ë•Ó ýTP %±!H•ɹìº ĺ~ eù‘ɹÝ]i6@E çyæ %w3—ËpË ÝŒ³Ø?sí
)—ó^ s Q8jU@ ‘VŽ+× FÂFzÁ•P)}àKa%©~†’™yÃkE\,xLBÑÁÛÛaf:ÕJ ÅÉ œzñif¼ e«,>LX§ÍÊ[
 F§†[Û DG%ÔS~BÕ- ² “xV Â"+K†Kæ¼šÓä2p4! •/x,| ^è, 0(c^eU Xâ,É™Ë“;j'^ÉçTr"ç-š8ÿ+W S ê WÄ
 Î-#•šröU ä 7°s“•x!-Žñ\p”• , -A 5 çɹyvrqÚ<:::><>êà_€ŽyÈ,ß ẽŸ’sÅ-œEFû[m YQ†m>éh¾d ÞŽXhÛ
 Bfm»-ž-^a,- €F •U€“Ñýui°sF×ãÉÕõ}i“sà îN wf ° ÜŒ{¹^ N f ÑI°Z”•Q:,•ÓÊ¶ !è?2øV .ªM2
 ñø¼ž•úüÕh|1:=,Êøæb<òɹûU ª=W>#V; Ý ³æNÀŠBŠõ .;7.H5+p š~øx5¹•MAÖ 7—Ë§(oí¶}h ói-(•L
 ¾L•Žĵ<Ô(İ6Ê—U °µªr9•“Û^³ɹß ÍŽ - Yñ 4h¾ (a V #~1Đ5— îPZf,S¶i¹ ,1Ê Oü§zÂJé ɹZ !syĐ Œ9=
 o†wÛ-0%o6ä_ªYeO5uZÝ¶O!•”jü‘uÀ57 - r6 = EÕ[]}òÝÓ@×•Lÿg½‡İ@öXâiáÇBlö_2ÿ ³é I]±Ÿøp¼J¾
 ¶ Ifæ-mÒ`ý£æIfÿ•â€- Oİ»mÑoĐëH «óê7)=L ÀE;ö {ua <ĀNPã³•ËS<Pûk ÚâÛ{Ú~w<š-Āñíýø@Ö€
 êxÕ÷<ú7ùĵ -†‘ œ



Shop in
Health & Personal Care

amazon.com



VIEW CART

WISH LIST

YOUR ACCOUNT

HELP

(Beta-What is this?)

WELCOME

YOUR STORE

BOOKS

APPAREL & ACCESSORIES

ELECTRONICS

TOYS & GAMES

MUSIC

CELL PHONES & SERVICE



SEE MORE STORES

Search

Browse Subjects

Bestsellers

Magazines

Corporate Accounts

e-books & docs

New & Used Textbooks

Used Books

Search:

Browse:

You clicked on this item...



Adrift

by [Steven Callahan](#)

Average Customer Review: ★★★★★
Out of Print--Limited Availability

15 used & new from \$3.49

[buy used:](#) \$3.49

From School Library Journal

YA Sailing Napoleon Solo in a single-handed Mini-Transat race from Spain to Antigua, Callahan was west of the Canary Islands when he realized that his sailboat was sinking. He managed to grab the life raft, a knife, his emergency duffel bag, a piece of mains'l, and a sleeping bag. These items became... [Read more](#)

You may also be interested in these items...

[Customers also shopped for](#)

Show items from:

- ▶ **All Products**
- [Books](#) (15)

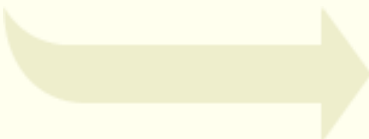

Survive the Savage Sea
by Dougal Robertson
[More like this](#)



Albatross
by Deborah Scaling Kiley, Meg Noonan
[More like this](#)

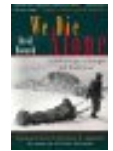

We Die Alone
by David Howarth
[More like this](#)

Capsized/the True Story of Four Men Adrift for 119 Days

by James Nalepka, Steven Callahan
[More like this](#)



Touching the Void
by Joe Simpson
[More like this](#)



Red Sky in Mourning
by Tami Oldham Ashcraft, Susea McGearhart
[More like this](#)



Deep Survival
by Laurence Gonzales
[More like this](#)



The Long Walk
by Slavomir Rawicz
[More like this](#)



Kon-Tiki
by Thor Heyerdahl
[More like this](#)

More results 

New at Amazon.com

Visit our new [Seasonal Tableware Store](#) and save up to 40% on Lenox, Spode, and more.

\$25 Off Tools & Hardware

\$25 Offer

Take \$25 off when you spend \$199 or more on [Tools & Hardware](#) products offered by Amazon.com. [Here's how](#) (restrictions apply).

New at Amazon.com



REPLACEMENTS.LTD.

Find more than 600,000 china, crystal, and silver products in the [Replacements, Ltd. Store](#).

Where's My Stuff?

- Track your [recent orders](#).
- View or change your orders in [Your Account](#).

Shipping & Returns

- See our [shipping rates & policies](#).
- [Return](#) an item (here's our [Returns Policy](#)).

Need Help?

- Forgot your password? [Click here](#).
- [Redeem](#) or [buy](#) a gift certificate.
- [Visit our Help department](#).

Search

for





Your Recent History

[Learn More](#)

Recently Viewed Products

-  [Longitude](#) by Dava Sobel
-  [Celestial Navigation for Yachtsmen](#) by Mary Blewitt
-  [Practical Celestial Navigation](#) by Susan Peterson Howell
-  [Celestial Navigation Simplified](#) VHS ~ William F. Buckley Jr.
-  [Latitude Hooks and Azimuth Rings](#) by Dennis Fisher

Customers who bought items in your Recent History also bought:

-   [The Sextant Handbook](#) by Bruce Bauer
-   [Celestial Navigation in a Nutshell](#) by Hewitt Schlereth

[▶ Visit the Page You Made](#)

Turn your past books purchases into \$\$\$
[Learn more](#) about selling at Amazon.com today!

[Top of Page](#)

[Books Search](#) | [Browse Subjects](#) | [Bestsellers](#) | [Magazines](#) | [Corporate Accounts](#)
[e-Books & Docs](#) | [Bargain Books](#) | [Used Books](#)

[Amazon.com Home](#) | [Directory of All Stores](#)

Our International Sites: [Canada](#) | [United Kingdom](#) | [Germany](#) | [Japan](#) | [France](#)

[Contact Us](#) | [Help](#) | [Shopping Cart](#) | [Your Account](#) | [Sell Items](#) | [1-Click Settings](#)

[Investor Relations](#) | [Press Releases](#) | [Join Our Staff](#)

[Conditions of Use](#) | [Privacy Notice](#) © 1996-2004, Amazon.com, Inc. or its affiliates



Search:

Browse:

You clicked on this item...



My Old Man and the Sea

by [David Hays](#)

Average Customer Review: ★★★★★
Usually ships in 24 hours

Price: \$10.40
You Save: \$2.60 (20%)
268 used & new from \$0.01



Eligible for **FREE Super Saver Shipping** on orders over \$25. [See details.](#)

Amazon.com

Or [buy used](#): \$0.01

David and Daniel Hays, father and son, designed and built a small boat together, then set out to sail it around the tip of South America, a journey that David had dreamed of ever since childhood. Along the way they fought and swore and sweated and shared triumphs large and small.

You may also be interested in these items...

[Customers also shopped for](#)

Show items from:

- ▶ **All Products**
- [Books](#) (20)
- [DVD](#) (1)
- [Music](#) (1)

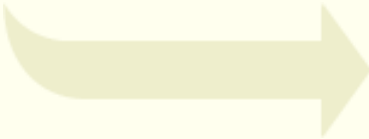

On Whale Island
by Daniel Hays
[More like this](#)



Sail Away
by Lena Lencek, et al
[More like this](#)

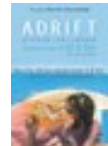

Adrift
by Steven Callahan
[More like this](#)



Close to the Wind
by Pete Goss
[More like this](#)



The Proving Ground
by G. Bruce Knecht
[More like this](#)



The Lobster Chronicles
by Linda Greenlaw
[More like this](#)

	 <p><u>OLD MAN AND THE SEA</u> by Ernest Hemingway More like this</p>	 <p><u>Gipsy Moth Circles the World</u> by Sir Francis Chichester More like this</p>	 <p><u>Godforsaken Sea</u> by Derek Lundy More like this</p>
--	---	--	--

[More results](#) ▶

<p>New at Amazon.com Visit our new Seasonal Tableware Store and save up to 40% on Lenox, Spode, and more.</p>	<p>\$25 Off Tools & Hardware Take \$25 off when you spend \$199 or more on Tools & Hardware products offered by Amazon.com. Here's how (restrictions apply).</p>	<p>New at Amazon.com</p>  <p>Find more than 600,000 china, crystal, and silver products in the Replacements, Ltd. Store.</p> <p>REPLACEMENTS LTD.</p>
--	---	--

<p>Where's My Stuff?</p> <ul style="list-style-type: none"> Track your recent orders. View or change your orders in Your Account. 	<p>Shipping & Returns</p> <ul style="list-style-type: none"> See our shipping rates & policies. Return an item (here's our Returns Policy). 	<p>Need Help?</p> <ul style="list-style-type: none"> Forgot your password? Click here. Redeem or buy a gift certificate. Visit our Help department.
--	--	---

Search **for**

Your Recent History
[Learn More](#)

<p>Recently Viewed Products</p> <ul style="list-style-type: none">  Adrift by Steven Callahan  Longitude by Dava Sobel  Celestial Navigation for Yachtsmen by Mary Blewitt  Practical Celestial Navigation by Susan Peterson Howell  Celestial Navigation Simplified VHS ~ William F. Buckley Jr. <p>▶ Visit the Page You Made</p>	<p>Customers who bought items in your Recent History also bought:</p> <table border="0"> <tr> <td data-bbox="795 1333 1185 1575">  <p> The Sextant Handbook by Bruce Bauer</p> </td> <td data-bbox="1185 1333 1591 1596">  <p> Celestial Navigation in a Nutshell by Hewitt Schlereth</p> </td> </tr> </table>	 <p> The Sextant Handbook by Bruce Bauer</p>	 <p> Celestial Navigation in a Nutshell by Hewitt Schlereth</p>
 <p> The Sextant Handbook by Bruce Bauer</p>	 <p> Celestial Navigation in a Nutshell by Hewitt Schlereth</p>		

Turn your past books purchases into \$\$\$
[Learn more](#) about selling at Amazon.com today!

[Books Search](#) | [Browse Subjects](#) | [Bestsellers](#) | [Magazines](#) | [Corporate Accounts](#)
[e-Books & Docs](#) | [Bargain Books](#) | [Used Books](#)

[Amazon.com Home](#) | [Directory of All Stores](#)

Our International Sites: [Canada](#) | [United Kingdom](#) | [Germany](#) | [Japan](#) | [France](#)

[Contact Us](#) | [Help](#) | [Shopping Cart](#) | [Your Account](#) | [Sell Items](#) | [1-Click Settings](#)

[Investor Relations](#) | [Press Releases](#) | [Join Our Staff](#)

[Conditions of Use](#) | [Privacy Notice](#) © 1996-2004, Amazon.com, Inc. or its affiliates



Search: Browse:

You clicked on this item...

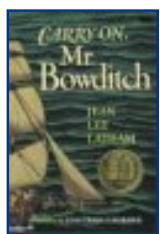

Carry On, Mr. Bowditch

by Jean Lee Latham, John O'Hara Cosgrave

Average Customer Review: ★★★★★

Out of stock

63 used & new from \$0.25

Or buy used: \$0.25

Review

"Illustrations, rich in detail, by John O'Hara Cosgrave II add authenticity and value."

You may also be interested in these items...

Customers also shopped for

Show items from:

- ▶ All Products
- Books (19)
- DVD (6)
- Music (3)
- Software (4)



The Bronze Bow

by Elizabeth George Speare

More like this



Johnny Tremain (Yearling Newbery)

by Esther Forbes, Lynd Ward

More like this

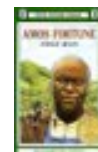

Amos Fortune

by Elizabeth Yates, Nora S. Unwin

More like this



Carry on Mr. Bowditch Study Guide

by Carole Pelttari

More like this



The Witch of Blackbird Pond (Laurel Leaf Books)

by ELIZABETH GEORGE SPEARE

More like this



The Trumpeter of Krakow

by Eric P. Kelly

More like this



I, Juan de Pareja

by Elizabeth Borton De Trevino

More like this



The Wheel on the School

by Meindert DeJong

More like this



The Matchlock Gun

by Walter Edmonds, Paul Lantz

More like this

[More results](#) 

New at Amazon.com

Visit our new [Seasonal Tableware Store](#) and save up to 40% on Lenox, Spode, and more.

\$25 Off Tools & Hardware

\$25 Offer

Take \$25 off when you spend \$199 or more on [Tools & Hardware](#) products offered by Amazon.com. [Here's how](#) (restrictions apply).

New at Amazon.com



REPLACEMENTS, LTD.

Find more than 600,000 china, crystal, and silver products in the [Replacements, Ltd. Store](#).

Where's My Stuff?

- Track your [recent orders](#).
- View or change your orders in [Your Account](#).

Shipping & Returns

- See our [shipping rates & policies](#).
- [Return](#) an item (here's our [Returns Policy](#)).

Need Help?

- Forgot your password? [Click here](#).
- [Redeem](#) or [buy](#) a gift certificate.
- [Visit our Help department](#).





Search

for

Your Recent History

[Learn More](#)

Recently Viewed Products

-  [My Old Man and the Sea](#) by David Hays
-  [Adrift](#) by Steven Callahan
-  [Longitude](#) by Dava Sobel
-  [Celestial Navigation for Yachtsmen](#) by Mary Blewitt
-  [Practical Celestial Navigation](#) by Susan Peterson Howell

Customers who bought items in your Recent History also bought:



 [The Sextant Handbook](#)
by Bruce Bauer



 [Celestial Navigation in a Nutshell](#)
by Hewitt Schlereth

▶ [Visit the Page You Made](#)

Turn your past books purchases into \$\$\$
[Learn more about selling at Amazon.com today!](#)

[Top of Page](#)

[Books Search](#) | [Browse Subjects](#) | [Bestsellers](#) | [Magazines](#) | [Corporate Accounts](#)
[e-Books & Docs](#) | [Bargain Books](#) | [Used Books](#)

[Amazon.com Home](#) | [Directory of All Stores](#)

Our International Sites: [Canada](#) | [United Kingdom](#) | [Germany](#) | [Japan](#) | [France](#)

[Contact Us](#) | [Help](#) | [Shopping Cart](#) | [Your Account](#) | [Sell Items](#) | [1-Click Settings](#)

[Investor Relations](#) | [Press Releases](#) | [Join Our Staff](#)

[Conditions of Use](#) | [Privacy Notice](#) © 1996-2004, Amazon.com, Inc. or its affiliates

Medieval Sourcebook: Geoffrey Chaucer: A Treatise on the Astrolabe c.. 1391

Geoffrey Chaucer lived appr. 1340-1400. "A Treatise on the Astrolabe" was once believed to have been written for a son of Chaucer's. "Lyte Lowys" (Little Lewis) is, however, presumably the son of a friend, Lewis Clifford. The boy probably died in 1391, which might explain why this work is unfinished. The text is the oldest known "technical manual" in the English language, and it was compiled from different foreign sources. The beginning is, however, Chaucer's very own.

Lyte Lowys my sone, I aperceyve wel by certeyne evidences thyn abilite to lerne sciences touching nombres and proporciouns; and as wel considre I thy besy praier in special to lerne the tretys of the Astrelabie. Than for as mochel as a filosofre saith, "he wrappith him in his frend, that condescendith to the rightfulle praier of his frend," therfore have I latitude of Oxenforde; upon which, by mediacioun of this litel tretys, I purpose to teche the a certain nombre of conclusions aperteynyng to the same instrument. I seie a certain of conclusions, for thre causes. The first cause is this: truste wel that alle the conclusions that han be founde, or ellys possibly might be founde in so noble an instrument as is an Astrelabie ben unknowe parfitly to eny mortal man in this regioun, as I suppose. An-other cause is this, that sothly in any tretis of the Astrelabie that I have seyn there be somme conclusions that wol not in alle thinges parformen her bihestes; and somme of hem ben to harde to thy tendir age of ten yeer to conceyve.

This tretis, divided in 5 parties, wol I shewe the under full light reules and naked wordes in Englissh, for Latyn ne canst thou yit but small, my litel sone. But natheles suffise to the these trewe conclusions in Englissh as wel as sufficith to these noble clerkes Grekes these same conclusions in Grek; and to Arabiens in Arabik, and to Jewes in Ebrew, and to the Latyn folk in Latyn; whiche Latyn folk had hem first out of othere dyverse langages, and writen hem in her owne tunge, that is to seyn, in Latyn. And God woot that in alle these langages and in many moo han these conclusions ben suffisantly lerned and taught, and yit by diverse reules; right as diverse pathes leden diverse folk the righte way to Rome. Now wol I preie mekely every discret persone that redith or herith this litel tretys to have my rude endityng for excusid, and my superfluite of wordes, for two causes. The first cause is for that curious endityng and hard sentence is ful hevy at onys for such a child to lerne. And the secunde cause is this, that sothly me semith better to writen unto a child twyes a god sentence, than he forgete it onys.

And Lowys, yf so be that I shewe the in my light Englissh as trewe conclusions touching this mater, and not oonly as trewe but as many and as subtile conclusiouns, as ben shewid in Latyn in eny commune tretys of the Astrelabie, konne me the more thank. And preie God save the king, that is lord of this langage, and alle that him feith berith and obeieth, everich in his degre, the more and the lasse. But considre wel that I ne usurpe not to have founden this werk of my labour or of myn engyn. I n'am but a lewd compiler of the labour of olde astrologiens, and have it translatid in myn Englissh oonly for thy doctrine. And with this swerd shal I sleen envie.

Prima pars. -The firste partie of this tretys shal rehearse the figures and the membres of thyn Astrelabie by cause that thou shalt have the gretter knowing of thyn owne instrument.

Secunda pars. -The secunde partie shal techen the worken the verrey practik of the forseide conclusiouns, as ferforth and as narwe as may be shewed in so small an instrument portatif aboute. For wel woot every astrologien that smallest fraccions ne wol not be shewid in so small an instrument as in subtile tables calculated for a cause.

Tertia pars. -The thirde partie shal contene diverse tables of longitudes and latitudes of sterres fixe for the Astrelabie, and tables of the declinacions of the sonne, and tables of longitudes of citees and townes; and tables as well for the governaunce of a klokke, as for to fynde the altitude meridian; and many another notable conclusioun after the kalenders of the reverent clerkes, Frere J. Somes and Frere N. Lenne.

Quarta pars. -The fourthe partie shal ben a theorike to declare the moevyng of the celestiall bodies with the causes. The whiche fourthe partie in speciall shal shewen a table of the verrey moevyng of the mone from houre to houre every day and in every signe after thyn almenak. Upon which table there folewith a canoun suffisant to teche as wel the manere of the worchyng of the same conclusioun as to knowe in oure orizonte with which degre of the zodiak that the mone arisith in any latitude, and the arisyng of any planete after his latitude fro the ecliptik lyne.

Quinta pars. -The fifthe partie shal be an introductorie, after the statutes of oure doctours, in which thou maist lerne a gret part of the generall rewles of theorik in astrologie. In which fifthe partie shalt thou fynden tables of equaciouns of houses after the latitude of Oxenforde; and tables of dignitees of planetes, and othere notefull thinges, yf God wol vouche saaf and his Moder the Maide, moo then I behete.

PART I

Here begynneth the descripcioun of thin Astralabie.

1. Thyn Astrolabie hath a ring to putten on the thombe of thi right hond in taking the height of thinges. And tak kep, for from henes forthward I wol clepen the heighte of any thing that is taken by the rewle "the altitude," withoute moo wordes.

2. This ryng renneth in a maner toret fast to the moder of thyn Astrelabie in so rowm a space that it distourbith not the instrument to hangen after his right centre.
3. The moder of thin Astrelabye is thikkest plate, perced with a large hool, that resceiveth in hir wombe the thynne plates compowned for diverse clymates, and thy reet shapen in manere of a nett or of a webbe of a loppe.
4. This moder is dividid on the bakhalf with a lyne that cometh descending fro the ring down to the netherist bordure. The whiche lyne, fro the forseide ring unto the centre of the large hool amidde, is clepid the south lyne, or ellis the lyne meridional. And the remenaunt of this lyne down to the bordure is clepid the north lyne, or ellis the lyne of midnyght.
5. Overthwart this forseide longe lyne ther crossith him another lyne of the same lengthe from eest to west. Of the whiche lyne, from a litel cros (+) in the bordure unto the centre of the large hool, is clepid the est lyne, or ellis the lyne orientale. And the remenaunt of this lyne, fro the forseide centre unto the bordure, is clepid the west lyne, or ellis the lyne occidentale. Now hast thou here the foure quarters of thin Astrolabie divided after the foure principales plages or quarters of the firmament.
6. The est syde of thyn Astrolabie is clepid the right syde, and the west syde is clepid the left syde. Forget not thys, litel Lowys. Put the ryng of thyn Astrolabie upon the thombe of thi right hond, and than wol his right side be toward thi lift side, and his left side wol be toward thy right side. Tak this rewle generall, as wel on the bak as on the wombe syde. Upon the ende of this est lyne, as I first seide, is marked a litel cros (+), where as evere moo generally is considerid the entring of the first degre in which the sonne arisith.
7. Fro this litel cros (+) up to the ende of the lyne meridionall, under the ryng, shalt thou fynden the bordure divided with 90 degrees; and by that same proporcioun is every quarter of thin Astrolabie divided. Over the whiche degrees there ben noumbres of augrym that dividen thilke same degres fro 5 to 5, as shewith by longe strikes bitwene. Of whiche longe strikes the space bitwene contenith a myle wey, and every degre of the bordure conteneth 4 minutes, this is seien, mynutes of an houre.
8. Under the compas of thilke degrees ben writen the names of the Twelve Signes: as Aries, Taurus, Gemini, Cancer, Leo, Virgo, Libra, Scorpio, Sagittarius, Capricornus, Aquarius, Pisces. And the nombre of the degrees of thoo signes be writen in augrym above, and with longe divisious fro 5 to 5, dyvidid fro the tyme that the signe entrith unto the last ende. But understond wel that these degres of signes ben everich of hem considred of 60 mynutes, and every mynute of 60 secundes, and so furth into smale fraccions infinite, as saith Alkabucius. And therefore knowe wel that a degre of the bordure contenith 4 minutes, and a degre of a signe conteneth 60 minutes, and have this in mynde.
9. Next this folewith the cercle of the daies, that ben figured in manere of degres, that contenen in nombre 365, dividid also with longe strikes fro 5 to 5, and the nombre in augrym writen under that cercle.

10. Next the cercle of the daies folewith the cercle of the names of the monthes, that is to say, Januarius, Februarius, Marcius, Aprilis, Maius, Junius, Julius, Augustus, September, October, November, December. The names of these monthes were clepid thus, somme for her propirtees and somme by statutes of lordes Arabiens, somme by othre lordes of Rome. Eke of these monthes, as liked to Julius Cesar and to Cesar Augustus, somme were compounded of diverse nombres of daies, as Julie and August. Than hath Januarie 31 daies, Februarie 28, March 31, Aprill 30, May 31, Junius 30, Julius 31, Augustus 31, September 30, October 31, November 30, December 31. Natheles, all though that Julius Cesar toke 2 daies out of Fevever and putte hem in his month of Juyll, and Augustus Cesar clepid the month of August after his name and ordeined it of 31 daies, yit truste wel that the sonne dwellith therfore nevere the more ne lasse in oon signe than in another.

11. Than folewen the names of the holy daies in the Kalender, and next hem the lettres of the A B C on whiche thei fallen.

12. Next the forseide cercle of the A B C, under the cross lyne, is marked the skale in manere of 2 squyres, or ellis in manere of laddres, that serveth by his 12 pointes and his dyvisiouns of ful many a subtil conclusioun. Of this forseide skale fro the cross lyne unto the verrey angle is clepid Umbra Versa, and the nethir partie is clepid Umbra Recta, or ellis Umbra Extensa.

13. Than hast thou a brod reule, that hath on either ende a square plate perced with certein holes, somme more and somme lasse, to resceyve the stremes of the sonne by day, and eke by mediacioun of thin eye to knowe the altitude of sterres by night.

14. Than is there a large pyn in manere of an extre, that goth thorough the hole that halt the tables of the clymates and the riet in the wombe of the moder; thorough which pyn ther goth a litel wegge, which that is clepid the hors, that streynith all these parties to-hepe. Thys forseide grete pyn in manere of an extre is ymagyned to be the Pool Artik in thyn Astralabie.

15. The wombe syde of thyn Astrelabie is also divided with a longe croys in 4 quarters from est to west, fro southe to northe, fro right syde to left side, as is the bakside.

16. The bordure of which wombe side is divided fro the point of the est lyne unto the point of the south lyne under the ring, in 90 degrees; and by that same proporcioun is every quarter divided, as is the bakside. That amountith 360 degrees. And understondwel that degres of this bordure ben aunswering and consentrike to the degrees of the equinoxiall, that is dividid in the same nombre as every lo othir cercle is in the highe hevne. This same bordure is divided also with 23 lettres capitals and a small crosse (+) above the south lyne, that shewith the 24 houres equals of the klokke. And, as I have seid, 5 of these degres maken a myle wey, and 3 milewei maken an heure. And every degre ot thys bordure contenith 4 minutes, and every minute 60 secundes. Now have I told the twyes.

17. The plate under the riet is discribed with 3 principal cercles, of whiche the leest is clepid the cercle of Cancre by cause that the heved of Cancre turnith evermo consentrik upon the same cercle. In this heved

of Cancer is the grettist declinacioun northward of the sonne, and therefore is he clepid solsticiun of somer; which declinacioun, after Ptholome, is 23 degrees and 50 minutes as wel in Cancer as in lo Capricorn. This signe of Cancer is clepid the tropik of somer, of *tropos*, that is to seien " ageynward. " For than beginneth the sonne to passen from us-ward.

The myddel cercle in wydnesse, of these 3, is clepid the cercle equinoxiall, upon which turnith evermo the hevedes of Aries and Libra. And understond wel that evermo thys cercle equinoxiall turnith justly from verrey est to verrey west as I have shewed the in the speer solide. This same cercle is clepid also Equator, that is the weyer of the day- for whan the sonne is in the hevedes of Aries and Libra, than ben the dayes and the nightes ylike of lengthe in all the world. And therefore ben these 2 signes called the equinoxiiis. And all that moeveth withinne the hevedes of these Aries and Libra, his moevyng is clepid north- ward; and all that moevith withoute these hevedes, his moevyng is clepid southward, as fro the equinoxiall. Tak kep of these latitudes north and south, and forget it nat. By this cercle equinoxiall ben considred the 24 houres of the klokke; for evermo the arisyng of 15 degrees of the equinoxiall makith an houre equal of the klokke. This equinoxiall is clepid the gurdel of the first moevyng, or ellis of the first moevable. And note that the first moevyng is clepid moevyng of the first moevable of the 8 speer, which moevyng is from est into west, and eft ageyn into est. Also it is clepid girdel of the first moevyng for it departith the first moevable, that is to seyn the spere. in two llike partyes evne distantz fro the poles of this world.

The widest of these 3 principale cercles is clepid the cercle of Capricorne, by cause that the heved of Capricorne turneth evermo consentrik upon the same cercle. In the heved of this forseid Capricorne is the grettist declinacioun southward of the sonne, and therefore it is clepid the solsticiun of wynter. This signe of Capricorne is also clepid the tropic of wynter, for than begynneth the sonne to come ageyn to us-ward.

18. Upon this forseide plate ben compassed certeyn cercles that highten almykanteras, of whiche somme of hem semen parfit cercles and somme semen inparfit. The centre that stonidith amyddes the narwest cercle is clepid the cenyth. And the netherist cercle, or the first cercle, is clepid the orizonte, that is to seyn, the cercle that divideth the two emysperies, that is, the partie of the lo hevne above the erthe and the partie bynethe. These almykanteras ben compowned by 2 and 2, all be it so that on diverse Astrelabies somme almykanteras ben divided by oon, and somme by two, and somme by thre, after the quantite of the Astrelabie. This forseide cenyth is ymaged to ben the verrey point over the crowne of thin heved. And also this cenyth is the verray pool of the ori- zonte in every region.

19. From this cenyth, as it semeth, there comen a maner croked strikes like to the clawes of a loppe, or elles like the werk of a wommans calle, in kervyng overthwart the almykanteras And these same strikes or divisious ben clepid azimutz, and thei dividen the orisounte of thin Astrelabie in 24 divisious. And these azymutz serven to knowe the costes of the firmament, and to othre conclusions, as for to knowe the cenyth of the sonne and of every sterre.

20. Next these azymutz, under the cercle of Cancer, ben there 12 divisious embelif, muche like to the

shap of the azemutz, that shewen the spaces of the hollres of planetes.

21. The riet of thin Astrelabie with thy zodiak, shapen in manere of a net or of a lopwebbe after the olde descripcioun, which thou maist turnen up and doun as thiself liketh, contenith certein nombre of sterres fixes, with her longitudes and latitudes determinat, yf so be that the maker have not errid. The names of the sterres ben writen in the margyn of the riet there as thei sitte, of whiche sterres lo the smale point is clepid the centre. And understond also that alle the sterres sitting within the zodiak of thin Astrelabie ben clepid sterres of the north, for thei arise by northe the est lyne. And all the remenaunt fixed oute of the zodiak ben clepid sterres of the south. But I seie not that thei arisen alle by southe the est lyne; wittenesse on Aldeberan and Algomeyse. Generaly understond this rewle, that thilke sterres that ben clepid sterres of the north arisen rather than the degre of her longitude, and alle the sterres of the south arisen after the degre of her longitude - this is to seyn, sterres fixed in thyn Astrelabie. The mesure of the longitude of sterres is taken in the lyne ecliptik of hevene, under which lyne, whan that the sonne and the mone be lyne-right, or ellis in the superficie of this lyne, than is the eclipse of the sonne or of the mone, as I shal declare, and eke the cause why. But sothly the ecliptik lyne of thy zodiak is the utterist bordure of thy zodiak there the degrees be marked.

Thy zodiak of thin Astrelabie is shapen as a compas which that contenith a large brede as after the quantite of thyn Astrelabie, in ensample that the zodiak in hevene is ymagyned to ben a superfice contenyng a latitude of 12 degrees, whereas alle the remenaunt of cercles in the hevene ben ymagyned verrey lynes withoute eny latitude. Amiddes this celestial zodiak is ymagined a lyne which that is clepid the ecliptik lyne, under which lyne is evermo the wey of the sonne. Thus ben there 6 degres of the zodiak on that oo syde of the lyne and 6 degrees on that othir. This zodiak is dividid in 12 principale divisiouns that departen the 12 signes, and, for the streitnesse of thin Astrolabie, than is every smal divisoun in a signe departed by two degrees and two! I mene degrees contenyng 60 mynutes. And this forseide hevenysse zodiak is clepid the cercle of the signes, or the cercle of the bestes, for " zodia " in langage of Grek sowneth " bestes " in Latyn tunge. And in the zodiak ben the 12 signes that han names of bestes, or ellis for whan the sonne entrith into eny of tho signes he takith the propirte of suche bestes, or ellis that for the sterres that ben ther fixed ben disposid in signes of bestes or shape like bestes, or elles whan the planetes ben under thilke signes thei causen us by her influence operaciouns and effectes like to the operaciouns of bestes.

And understond also that whan an hot planete cometh into an hot signe, than encrescith his hete; and yf a planete be cold, than amenusith his coldnesse by cause of the hote sygne. And by thys conclusioun maist thou take ensample in alle the signes, be thei moist or drie, or moeble or fixe, reknyng the qualite of the planete as I first seide. And everich of these 12 signes hath respect to a certeyn parcel of the body of a man, and hath it in governaunce; as Aries hath thin heved, and Taurus thy nekke and thy throte, Gemini thin armholes and thin armes, and so furth, as shall be shewid more pleyne in the 5 partie of this tretis.

This zodiak, which that is part of the speer, over-kervith the equinoxial, and-he over-kervith him ageyn in evene parties; and that oo half declineth so southward; and that othir northward, as plainly declarith the Tretys of the Speer.

Than hast thou a label that is shapen like a reule, save that it is streit and hath no plates on either ende with holes. But with the smale point of the forseide label shalt thou calcule thin equaciouns in the bordure of thin Astralabie, as by thin almury.

Thin almury is clepid the denticle of Capricorne, or ellis the calculer. This same almury sitt fix in the heved of Capricorne, and it serveth of many a necessarie conclusioun in equacions of thinges as shal be shewid.

Here endith the descripcioun of the Astrelabie and here begynne the conclusions of the Astrelabie.

PART II

1. To fynde the degre in which the sonne is day by day, after his cours aboute.

Rekne and knowe which is the day of thy month, and ley thy rewle up that same day, and than wol the verrey poynt of thy rewle sitten in the bordure upon the degre of thy sonne.

Ensample as thus: -The yeer of oure Lord 1391, the 12 day of March at midday, I wolde knowe the degre of the sonne. I soughte in the bakhalf of myn Astrelabie and fond the cercle of the daies, lo the whiche I knowe by the names of the monthes writen under the same cercle. Tho leyde I my reule over this forseide day, and fond the point of my reule in the bordure upon the firste degre of Aries, a litel within the degre. And thus knowe I this conclusioun.

Anothir day I wolde knowen the degre of my sonne, and this was at midday in the 13 day of December. I fond the day of the month in manere as I seide; tho leide I my rewle upon this forseide 13 day, and fond the point of my rewle in the bordure upon the firste degre of Capricorne a lite within the degre. And than had I of this conclusioun the ful experience.

2. To knowe the altitude of the sonne or of othre celestial bodies.

Put the ryng of thyn Astrelabie upon thy right thombe, and turne thi lift syde ageyn the light of the sonne; and remewe thy rewle up and doun til that the stremes of the sonne shine thorough bothe holes of thi rewle. Loke than how many degrees thy rule is areised fro the litel crois upon thin est lyne, and tak there the altitude of thi sonne. And in this same wise maist thou knowe by nyght the alti- tude of the mone or of brighte sterres.

This chapitre is so generall evere in oon that there nedith no more declaracioun; but forget it not.

3. To knowe every tyme of the day by light of the sonne; and every tyme of the nyght by the sterres fixe; and eke to knowe by nyght or by day the degre of eny signe that ascendith on the est orisonte, which that

is clepid comounly the ascendent, or ellis horoscopum.

Tak the altitude of the sonne whan the list, as I have seid, and set the degre of the sonne, in caas that it be befor the myddel of the day, among thyn almykanteras on the est syde of thin Astrelabie; and if it be after the myddel of the day, set the degre of thy sonne upon the west syde. Take this manere of setting for a general rule, ones for evere. And whan thou hast set the degre of thy sonne upon as lo many almykanteras of height as was the altitude of the sonne taken by thy rule, ley over thi label upon the degre of the sonne; and than wol the point of thi labell sitte in the bordure upon the verrey tyde of the day.

Ensample as thus: -The yeer of oure lord 1391, the 12 day of March, I wolde knowe the tyde of the day. I tok the altitude of my sonne, and fond that it was 25 degrees and 30 of minutes of height in the bordure on the bak side. Tho turned I myn Astrelabye, and by cause that it was befor mydday, I turned my riet and sette the degre of the sonne, that is to seyn the first degre of Aries, on the right side of myn Astrelabye upon 25 degrees and 30 mynutes of height among myn almykanteras. Tho leide I my label upon the degre of my sonne, and fond the point of my label in the bordure upon a capital lettre that is clepid an X. Tho rekned I alle the capitale lettres fro the lyne of mydnight unto this forseide lettre X, and fond that it was 9 of the klokke of the day. Tho loked I doun upon the est orizonte, and fond there the 20 degre of Geminis ascendyng, which that I tok for myn ascendent. And in this wise had I the experience for evermo in which manere I shulde knowe the tyde of the day and eke myn ascendent.

Tho wolde I wite the same nyght folewyng the houre of the nyght, and wroughte in this wise: - Among an heep of sterres fixe it liked me for to take the altitude of the faire white sterre that is clepid Alhabor, and fond hir sitting on the west side of the lyne of midday, 12 degrees of heighte taken by my rewle on the bak side. Tho sette I the centre of this Alhabor upon 12 degrees among myn almykanteras upon the west side, by cause that she w as founde on the west side. Tho leyde I my label over the degre of the sonne, that was descendid under the west orisounte, and rekned all the lettres capitals fro the lyne of midday unto the point of my Iabel in the bordure, and fond that it was passed 9 of the c lokke the space of 10 degrees. Tho lokid I doun upon myn est orisounte, and fond there 10 degrees of Scorpius ascendyng, whom I tok for myn ascendent. And thus lerned I to knowe onys for evere in which manere I shuld come to the houre of the nyght, and to myn ascendent, as verrely as may be taken by so smal an instrument.

But natheles this rule in generall wol I warne the for evere: - Ne make the nevere bold to have take a just ascendent by thin Astrelabie, or elles to have set justly a klokke, whan eny celestial body by which that thou wenyst governe thilke thinges be nigh the south Iyne. For trust wel, whan the sonne is nygh the meridional lyne, the degre of thc sonne renneth so longe consentrik upon the almykanteras that sothly thou shalt erre fro the just ascendent. The same conclusion sey I by the centre of eny sterre fix by nyght. And more over, by experience I wot wel that in our orisounte, from xi of the klokke unto oon of the klokke, in taking of a just ascendent in a portatif Astrelabie it is to hard to knowe - I mene from xi of the klokke before the houre of noon til oon of the klokke next folewyng.

4. *A special declaracioun of the ascendent.*

The ascendent sothly, as wel in alle nativites as in questions and eleccions of tymes, is a thing which that these astrologiens gretly observen. Wherefore me semeth convenyent, syth that I speke of the ascendent, to make of it speciall declaracioun.

The ascendent sothly, to take it at the largest, is thilke degre that ascendith at eny of these forseide tymes upon the est orisounte. And therefore, yf that eny planete ascende at thatt same tyme in thilke forseide degre, than hath he no latitude fro the ecliptik lyne, but he is than in the degre of the ecliptik which that is the degre of his longitude. Men sayn that thilke planete is *in horoscopo*.

But sothly the hous of the ascendent, that is to seyn, the first hous or the est angle, is a thing more brod and large. For, after the statutes of astrologiens, what celestial body that is 5 degrees above thilke degre that ascendith, or withinne that nombre, that is to seyn neer the degre that ascendith, yit rekne they thilke planete in the ascendent. And what planete that is under thilke degre that ascendith the space of 25 degrees, yit seyn thei that thilke planete is "like to him that is the hous of the ascendent." But sothly, if he passe the boundes of these forseide spaces, above or byneth, thei seyn that the planete is "fallyng fro the ascendent." Yit saien these astrologiens that the ascendent and eke the lord of the ascendent may be shapen for to be fortunat or infortunat, as thus: - A "fortunat ascendent" clepen they whan that no wicked planete, as Saturne or Mars or elles the Tayl of the Dragoun, is in the hous of the ascendent, ne that no wicked planete have noon aspect of enemyte upon the ascendent. But thei wol caste that thei have a fortunat planete in hir ascendent, and yit in his felicite; and than sey thei that it is wel. Further over thei seyn that the infortunyng of an ascendent is the contrarie of these forseide thinges. The lord of the ascendent, sey thei that he is fortunat whan he is in god place fro the ascendent, as in an angle, or in a succident where as he is in hys dignite and comfortid with frendly aspectes of planetes and wel resceyved; and eke that he may seen the ascendent; an that he be not retrograd, ne combust, ne joyned with no shrewe in the same signe; ne that he be not in his discencioun, ne joyned with no planete in his discencioun, ne have upon him noon aspect infortunat; and than sey thei that he is well.

Natheles these ben observaunces of judicial matere and rytes of payens, in whiche my spirit hath no feith, ne knowing of her *horoscopum*. For they seyn that every signe is departid in thre evene parties by 10 degrees, and thilke porcioun they clepe a face. And although that a planete have a latitude fro the ecliptik, yit sey somme folk, so that the planete arise in that same signe with eny degre of the forseide face in which his longitude is rekned, that yit is the planete *in horoscopo*, be it in nativyte or in eleccion, etc.

5. *To knowe the verrey equacioun of the degre of the sonne yf so be that it falle bitwene two almykanteras.*

For as muche as the almykanteras in thin Astrelabie ben compowned by two and two, where as somme almykanteras in sondry astrelabies be compowned by 1 and 1, or elles by 3 and 3, it is necessarie to thy lernyng to teche the first to knowe and worke with thin owne instrument. Wherefore whan that the degre

of thi sonne fallith bytwixe 2 almykanteras, or ellis yf thin almykanteras ben graven with over-gret a poynt of a compas (for bothe these thinges may causen error as wel in knowing of the tide of the day, as of the verrey ascendent), thou must worken in this wise: -

Set the degre of thy sonne upon the hyer almykanteras of bothe, and wayte wel where as thin almury touchith the bordure and set there a prikke of ynke. Sett doun agayn the degre of the sunne upon the nether almykanteras of bothe, and sett there another pricke. Remeve than thin almury in the bordure evene amiddes bothe prickes, and this wol lede justly the degre of thi sonne to sitte atwixe bothe almykanteras in his right place. Ley than thy label over the degre of thi sonne, and fynd in the bordure the verrey tyde of the day, or of the night. Andasverrailyshaltthoufynde upon thin est orisonte thin ascendent.

6. To knowe the spryng of the dawenyng and the ende of the evenyng, the whiche ben called the two crepuscules.

Set the nadir of thy sonne upon 18 degrees of height among thyn almykanteras on the west syde; and ley thy label on the degre of thy sonne, and than shal the point of thy label shewen the spryng of the day. Also set the nader of thy sonne upon 18 degrees of height among thin almykanteras on the est side, and ley over thy label upon the degre of the sonne, and with the point of thy label fynd in the bordure lo the ende of the evenyng, that is verrey nyght.

The nader of the sonne is thilke degre that is opposyt to the degre of the sonne, in the 7 signe, as thus: - every degre of Aries by ordir is nadir to every degre of Libra by ordre, and Taurus to Scorpioun, Gemini to Sagittarie, Cancer to Capricorne, Leo to Aquarie, Virgo to Pisces. And if eny degre in thy zodiak be derk, his adir shal declare hym.

7. To knowe the arch of the day, that sorne folk callen the day artificiall, fro sonne arisyng tyl it go to reste.

Set the degre of thi sonne upon thin est DriSonte and ley thy label on the degre of the sonne, and at the point of thy label in the bordure set a pricke. Turne than thy riet aboute tyl the degre of thy sonne sitte upon the west orisonte, and ley thy label upon the same degre of the sonne, and at the poynt of thy label set there another pricke. Rekne than the quantite of tyme in the bordure bitwixe bothe prickes, and tak there thyn arch of the day. The remenaunt of the bordure under the orisonte is the arch of the nyght. Thus maist thou rekne bothe arches, or every porcioun, of whether that the liketh. And by this manere of worching maist thou se how longe that eny sterre fix dwelleth above the erthe, fro tyme that he riseth til he go to reste. But the day naturall that is to seyn 24 houres, is the revolu- cioun of the equinoxial with as muche partie of the zodiak as the sonne of his propre moeving passith in the mene while.

8. To turne the houres inequales in houres equales.

Know the nombre of the degrees in the houres inequales, and depart hem by 15, and tak there thin houres

equales.

9. *To knowe the quantite of the day vulgar, that is to seyn fro spryng of the day unto verrey nyght.*

Know the quantite of thy crepuscles, as I have taught in the 2 chapitre bifore, and adde hem to the arch of thy day artificial, and tak there the space of all the hool day vulgar unto verrey night. The same manere maist thou worche to knowe the quantite of the vulgar nyght.

10. *To knowe the quantite of houres in, equales by day.*

Understond wel that these houres inequales ben clepid houres of planetes. And understond wel that som tyme ben thei lenger by day than by night, and som tyme the contrarie. But understond wel that evermo generally the houre inequal of the day with the houre inequal of the night contenen 30 degrees of the bordure, which bordure is evermo answeyng to the degrees of the equinoxial. Wherefore departe the arch of the day artificial in 12, and tak there the quantite of the houre inequale by day. And if thou abate the quantite of the houre inequale by day out of 30, than shal the remenaunt that levith parforme the houre inequale by night.

11. *To knowe the quantite of houres equales.*

The quantite of houres equales, that is to seyn the houres of the klokke, ben departid by 15 degrees alreedy in the bordure of thin Astrelaby, as wel by night as by day, generally for evere. What nedith more declaracioun?

Wherefore whan the list to knowe how many houres of the klokke ben passed, or eny part of eny of these houres that ben passed, or ellis how many houres lo or parties of houres ben to come fro such a tyme to such a tyme by day or by night, know the degre of thy sonne, and ley thy label on it. Turne thy ryet aboute joyntly with thy label, and with the poynt of it rekne in the bordure fro the sonne ariste unto that same place there thou desirist, by day as by nyght. This conclusioun wol I declare in the last chapitre of the 4 partie of this tretys so openly that ther shal lakke no word that nedith to the declaracioun.

12. *Special declaracioun of the houres of planetes.*

Understond wel that evermo, fro the arisyng of the sonne til it go to reste, the nadir of the sonne shal shewe the houre of the planete; and fro that tyme forward al the night til the sonne arise, than shal the verrey degre of the sonne shewe the houre of the planete.

Ensample as thus: -The xiiij day of March fyl upon a Saturday, peraventure, and atte risyng of the sonne I lo fond the secunde degre of Aries sittyng upon myn est orisonte, all be it that it was but litel. Than fond I the 2 degre of Libra, nadir of my sonne, discending on my west orisonte, upon which west orisonte every day generally, atte sonne arist, entrith the houre of every planete, after which planete the day berith his name, and endith in the next strike of the plate under the forseide west orisonte. And evere as the sonne

clymbith upper and upper, so goth his nadir downer and downer, teching by suche strikes the houres of planetes by ordir as they sitten in the hevene. The firste houre inequal of every Saturday is to Saturne, and the seconde to Jupiter, the thirde to Mars, the fourthe to the sonne, the fifte to Venus, the sixte to Mercurius, the seventhe to the mone. And then ageyn the 8 houre is to Saturne, the 9 is to Jupiter, the 10 to Mars, the 11 to the sonne, the 12 to Venus. And now is my sonne gon to reste as for that Saturday. Than shewith the verrey degre of the sonne the houre of Mercurie entring under my west orisonte at eve; and next hilr succedith the mone, and so furth by ordir planete after planete in houre after houre, all the nyght longe til the sonne arise. Now risith the sonne that Sondag by the morwe, and the nadir of the sonne upon the west orisonte shewith me the entring of the houre of the forseide sonne. And in this manere succedith planete under planete fro Saturne unto the mone, and fro the mone up ageyn to Saturne, houre after houre generally. And thus have I this conclusyoun.

13. To knowe the altitude of the sonne in myddes of the day that is clepid the altitude meridian.

Set the degre of the sonne upon the lyne meridional, and rekne how many degrees of almykanteras ben bitwyxe thin est orisonte and the degre of thy sonne; and tak there thin altitude meridian, this to seyn, the highest of the sonne as for that day. So maist thou knowe in the same lyne the heighest cours that eny sterre fix clymbeth by night. This is to seyn that whan eny sterre fix is passid the lyne meridional, than begynneth it to descende; and so doth the sonne.

14. To knowe the degre of the sonne by thy ryet, for a maner curiosite.

Sek besily with thy rule the highest of the sonne in mydde of the day. Turne than thin Astrelabie, and with a pricke of ynke marke the nombre of that same altitude in the lyne meridional; turne than thy ryet aboute tyl thou fynde a degre of thy zodiak according with the pricke, this is to seyn, sitting on the pricke. And in soth thou shalt finde but 2 degrees in all the zodiak of that condicioun; and yit lo thilke 2 degrees ben in diverse signes. Than maist thou lightly, by the sesoun of the yere, knowe the signe in which that is the sonne.

15. To knowe which day is lik to which day as of lengthe.

Loke whiche degrees ben ylike fer fro the hevedes of Cancer and Capricorne, and loke when the sonne is in eny of thilke degrees; than ben the dayes ylike of lengthe. This is to seyn that as longe is that day in that month, as was such a day in such a month- there varieth but litel.

Also, yf thou take 2 dayes naturales in the yere ylike fer fro either point of the equinoxiall in the opposyt parties, than as longe is the day artificiall of that oon day as is the night of that othir, and the contrarie.

16. This chapitre is a maner declaracioun to conclusiouns that folewen.

Understond wel that thy zodiak is departed in two halve circles, as fro the heved of Capricorne unto the heved of Cancer, and ageynward fro the heved of Cancer unto the heved of Capricorne. The heved of

Capricorne is the lowest point where as the sonne goth in wynter, and the heved of Cancer is the heighest point in which the sonne goth in somer. And therefore understond wel that eny two degrees lo that ben ylike fer fro eny of these two hevedes, truste wel that thilke two degrees hen of ilike declinacioun, be it southward or northward, and the daies of hem ben ilike of lengthe and the nyghtes also, and the shadewes ilyke, and the altitudes ylike atte midday for evere.

17. To knowe the verrey degre of eny maner sterre, straunge or unstraunge, after his longitude; though he be indeterminat in thin Astralabye, sothly to the trouthe thus he shal be knowe.

Tak the altitude of this sterre whan he is on the est syde of the lyne meridionall, as neigh as thou mayst gesse; and tak an ascendent anon right by som manere sterre fix which that thou knowist; and forget not the altitude of the firste sterre ne thyn ascendent. And whan that this is don, aspye diligently whan this same firste sterre passith eny thyng the south westward; and cacche him anon right in the same nombre of altitude on the west syde of this lyne meridional, as he was kaught on the est syde; and tak a newe ascendent anon-ryght by som manere sterre fix which that thou knowist, and forget not this secunde ascendent. And whan that this is don, rekne than how many degrees ben bitwixe the first ascendent and the secunde ascendent; and rekne wel the myddel degre bitwene bothe ascendentes, and set thilke myddel degre upon thyn est orizonte; and wayte than what degre that sitte upon the lyne meridional, and tak there the verrey degre of the ecliptik in which the sterre stondith for the tyme. For in the ecliptik is the longitude of a celestiall body rekned, evne fro the heved of Aries unto the ende of Pisces; and his latitude is rekned after the quantite of his declynacioun north or south toward the polys of this world.

As thus: -Yif it be of the sonne or of eny fix sterre, rekne hys latitude or his declinacioun fro the equinoxiall cerce; and if it be of a planete, rekne than the quantite of his latitude fro the ecliptik lyne, all be it so that fro the equinoxiall may the declinacioun or the latitude of eny body celestiall be rekned after the site north or south and after the quantite of his declinacioun. And right so may the latitude or the declinacioun of eny body celestiall, save oonly of the sonne, after hys site north or south and after the quantite of his declinacioun. be rekned fro the ecliptik lyne; fro which lyne alle planetes som tyme declinen north or south save oonly the forseide sonne.

18. To knowe the degrees of longitudes of fixe sterres after that they be determynat in thin Astrelabye, yf so be that thei be trewly sette.

Set the centre of the sterre upon the lyne meridionall, and tak kep of thy zodiak, and loke what degre of eny signe that sitte upon the same lyne meridionall at that same tyme, and tak there the degre in which the sterre stondith; and with that same degre cometh that same sterre unto that same lyne fro the orizonte.

19. To knowe with which degre of the zodiak eny sterre fix in thin Astrelabie arisith upon the est orizonte, all though his dwellyng be in another signe.

Set the centre of the sterre upon the est orizonte, and loke what degre of eny signe that sitt upon the same orizonte at that same tyme. And understond wel that with that same degre arisith that same sterre.

And thys merveyulous arisyng with a straunge degre in another signe is by cause that the latitude of the sterre fix is either north or south fro the equi- noxiall. But sothly the latitudes of planetes be comounly rekened fro the ecliptyk, by cause that noon of hem declyneth but fewe degrees out fro the brede of the zodiak. And tak god kep of this chapitre of arisyng of celestialle bodies; for truste wel that neyther mone ne sterre, as in our embelif orisonte, arisith with that same degre of his longitude save in oo cas, and that is whan they have no latitude fro the ecliptyk lyne. But natheles som tyme is everich of these planetes under the same lyne.

20. To knowe the declinacioun of eny degre in the zodiak fro the equinoxiall cercle.

Set the degre of eny signe upon the lyne meridionall, and rekne hys altitude in the almykanteras fro the est orisonte up to the same degre set in the forseide lyne, and set there a prikke; turne up than thy riet, and set the heved of Aries or Libra in the same meridionall lyne, and set there a nother prikke. And whan that this is don, conside the altitudes of hem bothe; for sothly the difference of thilke alti- tudes is the declinacioun of thilke degre fro the equinoxiall. And yf it so be that thilke degre be northward fro the equinoxiall, than is his declinacyoun north; yif it be southward, than is it south.

21. To knowe for what latitude in eny regioun the almykanteras of eny table ben com powned .

Rekene how many degrees of almykanteras in the meridionall lyne ben fro the cercle equinoxiall unto the cenyth, or elles from the pool artyk unto the north orisonte; and for so gret a latitude, or for so smal a latitude, is the table compowned.

22. To know in speciall the latitude of oure cowntre, I mene after the latitude of Oxenford, and the height of oure pool.

Understond wel that as fer is the heved of Aries or Libra in the equinoxiall fro oure orisonte as is the cenyth fro the pool artik; and as high is the pool artik fro the orisonte as the equinoxiall is fer fro the cenyth. I prove it thus by the latitude of Oxenford: understond wel that the height of oure pool artik fro oure north orisonte is 51 degrees and 50 mynutes; than is the cenyth fro oure pool artik 38 degrees and 10 mynutes; than is the equinoxiall from oure cenyth 51 degrees and 50 mynutes; than is oure south orisonte from oure equinoxiall 38 degres and 10 mynutes. Understond wel this rekenyng. Also forget not that the cenyth is 90 degrees of height from oure orisonte, and oure equinoxiall is 90 degres from oure pool artik. Also this shorte rule is soth, that the latitude of eny place in a regioun is the distaunce fro the cenyth unto the equinoxiall.

23. To prove evidently the latitude of eny place in a regioun by the preve of the height of the pool artik in that same place.

In som wynters nyght whan the firmament is cler and thikke sterred, wayte a tyme til that eny sterre fix sitte lyne-right perpendiculer over the pool artik, and clepe that sterre A; and wayte another sterre that

sitte lyne right under A, and under the pool, and clepe that sterre F. And understond wel that F is not considrid but oonly to declare that A sitte evene over the pool. Tak than anoon-right the altitude of A from the orisonte, and forget it not; let A and F goo fare wel tyl ageynst the dawenyng a gret while, and com than ageyn, and abid til that A is evene under the pool, and under F, for sothly than wol F sitte over the pool, and A wol sitte under the pool. Tak than eftsonys the altitude of A from the orisonte, and note as wel his secunde altitude as hys first altitude. And whan that this is doon, rekene how many degrees that the first altitude of A exceedith his secunde altitude, and tak half thilke porcioun that is exceedid and adde it to his secunde altitude, and tak there the elevacioun of thy pool, and eke the latitude of thyregioun; for these two ben of oo nombre, this is to seyn, as many degres as thy pool is elevat, so muche is the latitude of the regioun.

Ensamble as thus: - peraventure the altitude of A in the evenyng is 56 degrees of height; than wol his secunde altitude or the dawenyng be 48 degres that is 8 degrees lasse than 56, that was his first altitude att even. Tak than the half of 8 and adde it to 48 that was his secunde altitude, and than hast thou 52. Now hast thou the height of thy pool and the latitude of the regioun. But understond wel that to prove this con- clusioun and many another faire conclusioun, tholu must have a plomet hangyng on a lyne, heygher than thin heved, on a perche; and thilke lyne must hange evene perpendiculer bytwixe the pool and thin eye; and than shalt thou seen yf A sitte evene over the pool, and over F atte evene; and also yf F sitte evene over the pool and over A or day.

24. Another conclusioun to prove the height of the pool artik fro the orisonte.

Tak eny sterre fix that never descendith under the orisonte in thilke regioun, and considre his heighest altitude and his lowist altitude fro the orisonte, and make a nombre of bothe these altitudes; tak than and abate half that nombre, and tak there the elevacioun of the pool artik in that same regioun.

25. Another conclusioun to prove the latitude of the regioun.

Understond wel that the latitude of eny place in a regioun is verrelly the space bytwexe the cenyth of hem that dwellen there and the equinoxiall cercle north or south, takyng the mesure in the meridional lyne, as shewith in the almykanteras of thin Astrelabye. And thilke space is as much as the pool artike is high in that same place fro the orisonte. And than is the depressioun of the pool antartik, that is to seyn, than is the pool antartik, byneth the orisonte the same quantite of space neither more ne lasse.

Than if thou desire to knowe this latitude of the regioun, tak the altitude of the sonne in the myddel of the day, whan the sonne is in the hevedes of Aries or of Libra; for than moeveth the sonne in the lyne equinoxiall; and abate the nombre of that same sonnes altitude out of 90 degrees, and than is the remenaunt of the nombre that leveth the latitude of that regioun. As thus: - I suppose that the sonne is thilke day at noon 38 degrees of height; abate than 38 oute of 90; so leveth there 52; than is 52 degrees the latitude. I say not this but for ensamble; for wel I wot the latitude of Oxenford is certeyn minutes lasse, as thow might preve.

Now yf so be that the semeth to longe a tarieng to abide til that the sonne be in the hevedes of Aries or of Libra, than wayte whan the sonne is in eny othir degre of the zodiak, and conside the degre of his declinacioun fro the equinoxiall lyne; and if it so be that the sonnes declinacioun be northward fro the equinoxiall, abate than fro the sonnes altitude at non the nombre of his declinacioun, and than hast thou the height of the hevedes of Aries and Libra. As thus: -My sonne is peraventure in the first degre of Leoun, 58 degrees and 10 minutes of height at non, and his declinacioun is almost 20 degrees northward fro the equinoxiall; abate than thilke 20 degrees of declinacioun out of the altitude at non; than leveth there 38 degrees and odde minutes. Lo there the heved of Aries or Libra and thin equinoxiall in that regioun. Also if so be that the sonnes declinacioun be southward fro the equinoxiall, adde than thilke declinacioun to the altitude of the sonne at noon, and tak there the hevedes of Aries and Libra and thin equinoxiall; abate than the height of the equinoxial out of 90 degrees; than leveth there the distance of the pool of that regioun fro the equinoxiall. Or elles, if the list, tak the highest altitude fro the equinoxial of eny sterre fix that thou knowist, and tak the netherest elongacioun (lengthing) fro the same equinoxial lyne, and work in the manere forseid.

26. *Declaracioun of the ascensioun of signes.*

The excellence of the spere solide, amonges othir noble conclusiouns, shewith manyfest the diverse ascenciouns of signes in diverse places, as wel in the right cercle as in the embelif cercle. These auctours writen that thilke signe is cleped of right ascensioun with which more part of the cercle equinoxiall and lasse part of the zodiak ascendith- and thilke signe ascendith embelif with which lasse part of the equinoxiall and more part of the zodiak ascendith. Ferther-over they seyn that in thilke cuntrey where as the senith of hem that dwellen there is in the equinoxial lyne, and her orisonte passyng by the two poles of this world, thilke folk han this right cercle and the right orisonte; and evermore the arch of the day and the arch of the night is there ilike longe- and the sonne twies every yer passing thorough the cenith of hir heed, and two someres and two wynters in a yer han these forseide peple. And the almycanteras in her Astrelabyes ben streight as a lyne, so as it shewith in the figure.

The utilite to knowe the ascensions of signes in the right cercle is this: - Truste wel that by mediacioun of thilke ascensions these astrologiens, by her tables and her instrumentes, knowen verreily the ascensioun of every degre and minute in all the zodiak in the embelif cercle, as shal be shewed. And *nota* that this forseide right orisonte, that is clepid *Orison Rectum*, dividith the equinoxial into right angles; and the embelif orisonte where as the pool is enhaunced upon the orisonte, overkervith the equinoxiall in embilif angles, as shewith in the figure.

27. *This is the conclusioun to knowe the ascensions of signes in the right cercle, that is circulus directus.*

Set the heved of what signe the lyst to knowe his ascendyng in the right cercle upon the lyne meridionall, and wayte where thyn almury touchith the bordure, and set there a prikke; turne than thy riet westward til that the ende of the forseide signe sitte upon the meridional lyne and eftsonys wayte where thin almury touchith the bordure, and set there another pricke. Rekene than the nombre of degres in the bordure bitwixe bothe prikkes, and tak the ascensioun of the signe in the right cercle. And thus maist thou werke

with every porcioun of thy zodiak.

28. *To knowe the ascensions of signes in the embelif cercle in every regioun, I mene, in circulo obliquo.*

Set the heved of the signe which as the list to knowe his ascensioun upon the est orisonte, and wayte where thin almyry touchith the bordure, and there set a prikke. Turne than thy riet upward til that the ende of the same signe sitte upon the est orisonte, and wayte eftsonys where as thin almyry touchith the bordure, and set there a nother prikke. Rekene than the nombre of degrees in the bordure bitwyxe bothe prikkes and tak there the ascensioun of the signe in the embelif cercle. And understond wel that alle the signes in thy zodiak, fro the heved of Aries unto the ende of Virgo, ben clepid signes of the north fro the equinoxiall. And these signes arisen bitwyxe the verrey est and the verrey north in oure orisonte generally for evere. And alle the ignes fro the heved of Libra unto the ende of Pisces ben clepid signes of the south fro the equinoxial; and these signes arisen evermore bitwexe the verrey est and the verrey south in oure orisonte. Also every signe bitwixe the heved of Capricorne unto the ende of Geminis arisith on oure orisonte in lasse than 2 houres equales. And these same signes fro the heved of Capricorne unto the ende of Geminis ben cleped tortuose signes, or croked signes, for thei arise embelyf on oure orisonte. And these croked signes ben obedient to the signes that ben of right ascensioun. The signes of right ascencioun ben fro the heved of Cancer unto the ende of Sagittarie; and these signes arisen more upright, and thei ben called eke sovereyn signes and everich of hem arisith in more space than in 2 houres. Of whiche signes Gemini obeieith to Cancer, and 'raurus to Leo, Aries to Virgo, Pisces to Libra, Aquarius to Scorpioun, and Capricorne to Sagittarie. And thus evermore 2 signes that ben ilike fer fro the heved of Capricorne obeyen everich of hem til othir.

29. *To knowe justly the 4 quarters of the world, as Est, West, North, and South.*

Tak the altitude of thy sonne whan the list, and note wel the quarter of the world in which the sonne is for the tyme by the azymutz. Turne than thin Astrelabie, &nd set the degre of the sonne in the almykanteras of his altitude on thilke syde that the sonne stant, as is the manere in takyng of houres, and ley thy label on the degre of the sonne; and rekene how many degrees of the bordure ben bitwixe the Iyne meridional and the point of thy label, and note wel that nombre. Turne than ageyn thin Astrelabie, and set the point of thy gret rule there thou takist thin altitudes upon as many degrees in his bordure fro his meridional as was the point of thy label fro the lyne meridional on the wombe side. Take than thin Astrelabie with bothe hondes sadly and slyghly, and lat the sonne shyne thorough bothe holes of thy rule, and slyghly in thilke shynyng lat thin Astrelabie kouche adoun evene upon a smothe ground, and than wol the verrey lyne meridional of thin Astrelabie lye evene south, and the est Iyne wol lye est, and the west Iyne west, and the north lyne north, so that thou worke softly and avysely in the kouching. And thus hast thou the 4 quarters of the firmament.

30. *To knowe the altitude of planetes fro the wey of the sonne, whethir so they be north or south fro the forseide wey.*

Loke whan that a planete is in the lyne meridional, yf that hir altitude be of the same height that is the

degre of the sonne for that day, and than is the planete in the verrey wey of the sonne and hath no latitude. And if the altitude of the planete be heigher than the degre of the sonne, than is the planete north fro the wey of the sonne such a quantite of latitude as shewith by thin almykanteras. And if the altitude of the planete be lasse than the degre of the sonne, than is the planete south fro the wey of the sonne such a quantite of latitude as shewith by thin almykanteras. This is to seyn, fro th(wey where as the sonne went thilke day but not fro the wey of the sonne in every place of the zodiak.

31. To knowe the cenyth of the arising of the sonne, this is to seyn, the partie of the orisonte in which that the sonne arisith.

Thou must first considere that the sonne arisith not alwey verrey est, but somtyme by northe the est and somtyme by south the est. Sothly the sonne arisith nevere moo verrey est in oure orisonte, but he be in the heved of Aries or Libra. Now is thin orisonte departed in 24 parties by thin azimutes in significacioun of 24 parties of the world; al be it so that shipmen rekene thilke parties in 32. Than is there no more but wayte ill which azimut that thy sonne entrith at his arisyng, and take there the cenith of the arisyng of the sonne.

The manere of the divisioun of thin Astrelabie is this, I mene as in this cas: - First it is divided in 4 plages principalis with the lyne that goth from est to west; and than with another lyne that goth fro south to north; than is it divided in smale parties of azymutz, as est, and est by south, where as is the first azymut above the est lyne; and so furth fro partie to partie til that thou come ageyn unto the est lyne. Thus maist thou understonde also the cenyth of eny sterre, in which partie he riseth.

32. To knowe in which partie of the firmament is the conjunccyoun.

Considerere the tyme of the conjunccyoun by the kalender, as thus: - Loke hou many houres thilke conjunccyoun is fro the midday of the day precedent, as shewith by the canon of thy kalender. Rekene than thilke nombre of houres in the bordure of thin Astrelabie, as thou art wont to do in knowyng of the houres of the day or of the nyght, and ley thy label over the degre of the sonne, and than wol the point of thy label sitte upon the houre of the conjunccyoun. Loke than in which azymut the degre of thy sonne sittith, and in that partie of the firmament is the conjunccyoun.

33. To knowe the cenyth of the altitude of the sonne.

This is no more to seyn but eny tyme of the day tak the altitude of the sonne, and by the azymut in which he stonidith maist thou seen in which partie of the firmament he is. And in the same wise maist thou seen by night, of eny sterre, whether the sterre sitte est or west, or north or south, or eny partie bitwene, after the name of the azimut in which the sterre stonidith.

34. To knowe sothly the degre of the longitude of the mone, or of eny planete that hath no latitude for the tyme fro the ecliptik lyne.

Tak the altitude of the mone, and rekne thy altitude up among thyn almykanteras on which syde that the mone stondith, and set there a prikke. Tak than anon-right upon the mones syde the altitude of eny sterre fix which that thou knowist, and set his centre upon his altitude among thyn almykanteras there the sterre is founde. Wayte than which degre of the zodiak touchith the prykke of the altitude of the mone, and tak there the degre in which the mone stondith. This conclusioun is verrey soth, yf the sterres in thin Astrelabie stonden after the trouthe. Comoun tretes of the Astrelabie ne maken non excepcioun whether the mone have latitude or noon, ne on wheyther syde of the mone the altitude of the sterre fixe be taken.

And *nota* that yf the mone shewe a himself by light of day, than maist thou worche this same conclusioun by the sonne, as wel as by the fixe sterre.

35. This is the worchyng of the conclusioun to knowe yf that eny planete be direct or retrograd.

Tak the altitude of any sterre that is clepid a planete, and note it wel; and tak eke anon the altitude of any sterre fix that thou knowist, and note it wel also. Com than ageyn the thridde or the fourthe nyght next folewing, for than shalt thou perceyve wel the moeving of a planete, whether so he moeve forward or bakward. Awayte wel than whan that thy sterre fixe is in the same altitude that she was whan thou toke hir firste altitude. And tak than eft-sones the altitude of the forseide planete and note it wel; for truste wel yf so be that the planete be on the right syde of the meridional lyne, so that his secunde altitude be lasse than hys first altitude was, than is the planete direct; and yf he be on the west syde in that condicioun, than is he retrograd. And yf so be that this planete be upon the est side whan his altitude is ytaken, so that his secunde altitude be more than his first altitude, than is he retrograd. And if he be on the west syde, than is he direct. But the contrarie of these parties is of the cours of the mone; for certis the mone moeveth the contrarie from othre planetes as in hir epicycle, but in noon othir manere.

36. The conclusioun of equaciouns of houses after the Astrelabie.

Set the begynnnyng of the degre that ascendith upon the ende of the 8 houre unequal; than wol the begynnnyng of the 2 hous sitte upon the lyne of mydnight. Remeve than the degre that ascendith, and set him on the ende of the 10 houre unequal, and than wol the begynnnyng of the 3 hous sitte up on the mydnight lyne. Bring up ageyn the same degre that ascended first, and set him upon the est orisonte, and than wol the begynnnyng of the 4 hous sitte upon the lyne of mydnight. Tak than the nader of the degre that first ascendid, and set him in the ende of the 2 houre unequal; and than wol the begynnnyng of the 5 hous sitte upon the Iyne of mydnight. Set than the nader of the ascendent in the ende of the 4 houre unequal, and than wol the begynnnyng of the 6 hous sitte on the mydnight lyne. The begynnnyng of the 7 hous is nader of the ascendent, and the begynnnyng of the 8 hous is nader of the 2 hous, and the begynnnyng of the 9 hous is nader of the 3, and the begynnnyng of the 10 hous is nader of the 4, and the begynnnyng of the 11 hous is nader of the 5, and the begynnnyng of the 12 hous is nader of the 6.

37. Another maner of equaciouns of houses by the Astrelabie.

Tak thin ascendent, and than hast thou thy 4 angles; for wel thou wost that the opposit of thin ascendent,

that is to seyn, the begynnyng of the 7 hous, sitt upon the west orisonte, and the begynnyng of the hous sitt upon the lyne meridional, and his opposyt upon the lyne of mydnight. Than ley thy label over the degre that ascendith, and rekne fro the point of thy label alle the degrees in the bordure tyl thou come to the meridional lyne; and departe alle thilke degrees in 3 evene parties, and take there the evene equacions of 3 houses; for ley thy label over everich of these 3 parties, and than maist thou se by thy label, lith in the zodiak, the begynnyng of everich of these same houses fro the ascendent; that is to seyn the begynnyng of the 12 hous next above thin ascendent, the begynnyng of the 11 hous, and than the 10 upon the meridional lyne, as I first seide. The same wise worch thou fro the ascendent down to the lyne of mydnyght, and thus hast thou othre 3 houses; that is to seyn, the begynnyng of the 2, and the 3, and the 4 hous. Than is the nader of these 3 houses the begynnyng of the 3 houses that folewen.

38. To fynde the lyne meridional to dwelle fix in eny certeyn place.

Tak a round plate of metal; for werpyng, the brodder the better; and make there upon a just compas a lite within the bordure. And ley this rounde plate upon an evene ground, or on an evene ston, or on an evene stok fix in the ground; and ley it evene by a level. And in the centre of the compas styke an evene pyn, or a wyr, upright, the smaller the better; set thy pyn by a plom-rule evene upright, and let this pyn be no lenger than a quarter of the dyametre of thy compas, fro the centre amiddes. And wayte bisely aboute 10 or 11 of the klokke, whan the sonne shineth, whan the shadwe of the pyn entrith enythyng within the cercle of thy compas an heer-mele- and marke there a pricke with inke. Abid than stille waityng on the sonne til after 1 of the klokke, til that the shadwe of the wyr, or of the pyn, passe enything out of the cercle of the compas, be it nevere so lyte, and set there another pricke of ynke. Tak than a compas, and mesure evene the myddel bitwixe bothe prickes, and set there a prikke. Tak me than a rule and draw a strike evene a-lyne, fro the pyn unto the middel prikke- and tak there thi lyne heved. And it is cleped the lyne meridional, for in what place that eny man ys at any tyme of the yer, whan that the sonne, by mevyng of the firmament, cometh to his verrey meridian place, than is it verrey mydday, that we clepen oure non, as to thilke man. And therefore is it clepid the Iyne of mydday. And nota that evermore of eny 2 cytes or 2 townes, of which that oo town approachith more toward the est than doth that othir town, truste wel that thilke townes han diverse meridians. Nota also that the arch of the equinoxial that is contened or bownded bitwixe the 2 meridians is clepid the longitude of the toun. And yf so be that two townes have ilike meridian or oon meridian, than is the distaunce of hem both ilike fer fro the est, and the contrarie; and in this manere thei change not her meridian. But sothly thei chaungen her almykanteras, for the enhaunsyng of the pool and the distance of the sonne.

The longitude of a climat is a lyne ymaged fro est to west ilike distant fro the equinoxiall. And the latitude of a climat may be cleped the space of the erthe fro the begynnyng of the first clymat unto the verrey ende of the same clymat evene direct ageyns the pool artyke. Thus sayn somme auctours; and somme of hem sayn that yf men clepe the latitude of a cuntrey the arch meridian that is contened or intercept bitwix the cenyth and the equinoxial, than say they that the distance fro the equinoxial unto the ende of a climat evene ageynst the pool artik is the latitude of a clymat forsoothe.

40. To knowe with which degre of the zodiak that eny planete ascendith on the orisonte, whether so that his latitude be north or south.

Know by thin almenak the degre of the ecliptik of eny signe in which that the planete is rekned for to be, and that is clepid the degre of his longitude. And know also the degre of his latitude fro the ecliptik north or south. And by these ensamples folewyng in speciall maist thou worche forsothe in every signe of the zodiak: -

The degre of the longitude per-aventure of Venus or of another planete was 6 of Capricorne, and the latitude of hir was northward 2 degrees fro the ecliptik lyne. Than tok I a subtil compas and clepid that oo point of my compas . and that other point F. Than tok I the point of A and sette it in the ecliptik lyne in my zodiak in the degre of the longitude of Venus, that is to seyn, in the 6 degre of Capricorne; and than sette I the point of F upward in the same signe by cause that latitude was north upon the latitude of Venus, that is to seyn, in the 6 degre fro the heved of Capricorne; and thus have I 2 degrees bitwixe my two prickes. Than leide I down softly my compas, and sette the degre of the longitude upon the orisonte; tho tok I and waxed my label in manere of a peire tables to receyve distinctly the prickes of my compas. Tho tok I thys forseide label, and leyde it fix over the degre of my longitude; tho tok I up my compas and sette the point of A in the wax on my label, as evene as I koude gesse, over the ecliptik lyne in the ende of the longitude, and sette the point of F endelong in my label upon the space of the latitude, inward and over the zodiak, that is to seyn northward fro the ecliptik. Than leide I doun my compas, and loked wel in the wey upon the prickes of A and of F; tho turned I my ryet til that the pricke of F satt upon the orisonte; than saw I wel that the body of Venus in hir latitude of 2 degrees septentrional ascendid, in the ende of the 6 degre, in the heved of Capricorne.

And *nota* that in this manere maist thou worche with any latitude septentrional in alle signes. But sothly the latitude meridional of a planete in Capricorne ne may not be take by cause of the litel space bitwixe the ecliptik and the bordure of the Astrelabie; but sothely in all othre signes it may.

2 pars hujus conclusio.

Also the degre peraventure of Jupiter, or of another planete, was in the first degre of Piscis in longitude, and his latitude was 2 degrees meridional; tho tok I the point of A and sette it in the first degre of Piscis on the ecliptik; and than sette I the point of F downward in the same signe by cause that the latitude was south 2 degrees, that is to seyn, fro the heved of Piscis; and thus have 2 degres bitwexe bothe 66 prikkes. Than sette I the degre of the longitude upon the orisonte; tho tok I my label, and leide it fix upon the degre of the longitude; tho sette I the point of A on my label evene over the ecliptik lyne in the ende of the degre of the longitude, and sette the point of F endlong in my label the space of 2 degres of the latitude outward fro the zodiak (this is to seyn southward fro the ecliptik toward the bordure), and turned my riet til that the pricke of F saat upon the orisonte. Than say I wel that the body of Jupiter in his latitude of 2 degres meridional ascendid with 8 degres of Piscis in horoscopo. And in this manere maist thou worche with any latitude meridional, as I first seide, save in Capricorne. And yf thou wilt pleye this craft with the arisyng of the mone, loke thou rekne wel hir cours houre off by houre, for she ne dwellith not in a degre of hir longitude but litel while, as thow wel knowist. But natheles yf thou rekne hir verrey moevyng by thy tables houre after houre, [thou shalt do wel ynow].

Supplementary Propositions

41. *Umbra Recta.*

Yif it so be that thou wilt werke by *umbra recta*, and thou may come to the bas of the tour, in this maner thou shalt werke. Tak the altitude of the tour by bothe holes, so that thy rewle ligge even in a poynt. Ensample as thus: I see him thorw at the poynt of 4; than mete I the space between me and the tour, and I finde it 20 feet; than beholde I how 4 is to 12, right so is the space betwixe thee and the tour to the altitude of the tour. For 4 is the thridde part of 12, so is the space between thee and the tour the thridde part of the altitude of the tour; than thryes 20 feet is the heyghte of the tour, with adding of thyn owne persone to thyn eye. And this rewle is so general in *umbra recta*, fro the poynt of oon to 12. And yif thy rewle falle upon 5, than is 5 12-partyes of the heyght the space between thee and the tour; with adding of thyn owne heyghte.

42. *Umbra Versa.*

Another maner of werkinge, by *umbra versa*. Yif so be that thou may nat come to the bas of the tour, I see him thorw the nombre of 1; I sette ther a prikke at my fot; than go I neer to the tour, and I see him thorw at the poynt of 2, and there I sette another prikke; and I beholde how 1 hath him to 12, and ther finde I that it hath him twelfe sythes; than beholde I how 2 hath him to 12, and thou shalt finde it sexe sythes; than thoushaltfinde that as 12 above 6 is the nombre of 6, right so is the space between thy two prikkes the space of 6 tymes thyn altitude. And note, that at the ferste altitude of 1, thou settest a prikke; and afterward, whan thou seest him at 2, ther thou settest another prikke; than thou findest between two prikkys 60 feet; than thou shalt finde that 10 is the 6-party of 60. And then is 10 feet the altitude of the tour. For other poyntis, yif it fille in *umbra versa*, as thus: I sette caas it fill upon 2, and at the secunde upon 3; than schalt thou finde that 2 is 6 partyes of 12; and 3 is 4 partyes of 12; than passeth 6 4, by nombre of 2; so is the space between two prikkes twyes the heyghte of the tour. And yif the differens were thryes, than shulde it be three tymes; and thus mayst thou werke fro 2 to 12; and yif it be 4, 4 tymes; or 5, 5 tymes; *et sic de ceteris*.

43. *Umbra Recta.*

Another maner of wyrking, by *umbra recta*. Yif it so be that thou mayst nat come to the baas of the tour, in this maner thou schalt werke. Set thy rewle upon 1 till thou see the altitude, and set at thy foot a prikke. Than set thy rewle upon 2, and behold what is the differense between 1 and 2, and thou shalt finde that it is 1. Than mete the space between two prikkes, and that is the 12 partie of the altitude of the tour. And yif ther were 2, it were the 6 partye; and yif ther were 3, the 4 partye; *et sic deinceps*. And note, yif it were 5, it were the 5 party of 12; and 7, 7 party of 12; and note, at the altitude of thy onclusioun, adde the stature of thyn heyghte to thyn eye.

* * * * *

44. *Another maner conclusion, to knowe the mene mote and the argumentis of any planete. To know the mene mote and the argumentis of every planete fro yere to yere, from day to day, from houre to houre, and from smale fraccionis infinite.*

In this maner shalt thou worche; consider thy rote first, the whiche is made the beginning of the tables fro the yer of oure Lord 1397, and enter hit into thy slate for the laste meridie of December- and than consider the yer of oure Lord, what is the date, and behold whether thy date be more or lasse than the yer 1397. And yf hit so be that hit be more, loke how many yeres hit passeth, and with so many enter into thy tables in the first Iyne theras is writen *anni collecti et expansi*. And loke where the same planet is written in the hed of thy table, and than loke what thou findest in direct of the same yer of oure Lord which is passid, be hit 8, or 9, or 10, or what nombre that evere it be, til the tyme that thou come to 20, or 40, or 60. And that thou findest in direct wryt in thy slate under thy rote, and adde hit togeder, and that is thy mene mote, for the laste meridian of the December, for the same yer which that thou hast purposed. And if hit so be that hit passe 20, consider wel that fro 1 to 20 ben *anni expansi*, and fro 20 to 3000 ben *anni collecti*; and if thy number passe 20, than tak that thou findest in direct of 20, and if hit be more, as 6 or 18, than tak that thou findest in direct thereof, that is to sayen, signes, degrees, minutes, and secoundes, and adde togedere unto thy rote; and thus to make rotes. And note that if hit so be that the yer of oure Lord be lasse than the rote, which is the yer of oure Lord 1397, than shalt thou wryte in the same wyse furst thy rote in thy slate, and after enter into thy table in the same yer that be lasse, as I taught before; and than consider how many signes, degrees, minutes, and secoundes thyn entringe conteyneth. And so be that thebe 2 entrees, than adde hem togeder, anafter withdraw hem from the rote, the yer of oure Lord 1397; and the residue that levethe is thy mene mote for the laste meridie of December, the whiche thou hast purposed; and if hit so be that thou wolt weten thy mene mote for any day, or for any fraccioun of day, in this maner thou shalt worche. Make thy rote fro the laste day of December in the maner as I have taught, and afterward behold how many monethes, dayes, and houres ben passid from the meridie of December, and with that enter with the laste moneth that is ful passed, and take that thou findest in direct of him, and wryt hit in thy slate; and enter with as many dayes as be more, and wryt that thou findest in direct of the same planete that thou worchest for; and in the same wyse in the table of houres, for houres that ben passed, and adde alle these to thy rote; and the residue is the mene mote for the same day and the same houre.

45. *Another manere to knowe the mene mote.*

Whan thou wolt make the mene mote of eny planete to be by Arsechieles tables tak thy rote, the whiche is for the yer of oure Lord 1397; and if so be that thy yer be passid the date, wryt that date, and than wryt the number of the yeres. Than withdraw the yeres out of the yeres that ben passed that rote. Ensampul as thus: the yer of oure Lord 1400, I wolde witen, precise, my rote; than wroot I furst 1400. And under that number I wrot a 1397; than withdraw I the laste number out of that, and than fond I the residue was 3 yer; I wiste that 3 yer was passed fro the rote, the whiche was written in my tables. Than afterward soghte I in my tables the *annis collectis et expansis*, and among myn expanse yeres fond I 3 yeer. Than tok I alle the signes, degrees, and minutes, that I fond direct under the same planete that I wroghte for, and wroot so many signes, degrees, and minutes in my slate, and afterward added I to signes, degrees, minutes, and secoundes, the whiche I fond in my rote the yer of oure Lord 1397; and kepte the residue; and than had I

the mene mote for the laste day of December. And if thou woldest wete the mene mote of any planete in March April, or May, other in any other tyme or moneth of the yer, loke how many monethes and dayes ben passed from the laste day of December, the yer of oure Lord 1400; and so with monethes and dayes enter into thy table ther thou findest thy mene mote ywriten in monethes and dayes, and tak alle the signes, degrees, minutes, and secoundes that thou findest ywrite in direct of thy monethes, and adde to signes, degrees, minutes, and secoundes that thou findest with thy rote the yer of oure Lord 1400, and the residue that leveth is the mene mote for that same day. And note, if hit so be that thou woldest wete the mene mote in any yer that is lasse than thy rote, withdraw the number of so many yeres as hit is lasse than the yer of oure Lord a 1397, and kep the residue; and so many yeres, monethes, and dayes enter into thy tabels of thy mene mote. And tak alle the signes, degrees, and minutes, and secoundes, that thou findest in direct of alle the yeres, monethes, and dayes, and wryt hem in thy slate; and above thilke number wryt the signes, degrees, minutes and secoundes, the whiche thou findest with thy rote the yer of oure Lord a 1397; and withdraw alle the nethere signes and degrees fro the signes and degrees, minutes, and secoundes of other signes with thy rote; and thy residue that leveth is thy mene mote for that day.

46. For to knowe at what houre of the day or of the night, shal be flod or ebbe.

First wite thou certainly, how that haven stondest, that thou list to werke for; that is to say in which place of the firmament the mone being, maketh full see. Than awayte thou redily in what degree of the zodiak that the mone at that tyme is inne. Bring furth than the label, and set the point therof in that same cost that the mone maketh flod, and set thou there the degree of the mone according with the egge of the label. Than afterward awayte where is than the degree of the sonne, at that tyme. Remeve thou than ttle label fro the mone, and bring and set it justly upon the degree of the sonne. And the point of the label shal than declare to thee, at what houre of the day or of the night shal be flod. And there also maist thou wite by the same point of the label, whether it be, at that same tyme, flod or ebbe, or half flod, or quarter flod, or ebbe, or half or quarter ebbe; or ellis at what houre it was last, or shal be next by night or by day, thou than shalt esely knowe, &c. Furthermore, if it so be that thou happe to worke for this matere aboute the tyme of the conjunccioun, bring furth the degree of the mone with the label to that coste as it is before seyde. But than thou shalt understonde that thou may not bringe furth the label fro the degree of the mone as thou dide before; for-why the sonne is than in the same degree with the mone. And so thou may at that tyme by the point of the label unremoved knowe the houre of the flod or of the ebbe, as it is before seyde, &c. And evermore as thou findest the mone passe fro the sonne, so remeve thou the label than fro the degree of the mone, and bring it to the degree of the sonne. And work thou than as thou dide before, &c. Or elles know thou what houre it is that thou art inne, by thyn instrument. Than bring thou furth fro thennes the label and ley it upon the degree of the mone, and therby may thou wite also whan it was flod, or whan it wol be next, be it night or day; &c.

[End]

Edition by F. N. Robinson, originally on the Origo Website in Sweden

This text is part of the [Internet Medieval Source Book](#). The Sourcebook is a collection of public domain and copy-permitted texts related to medieval and Byzantine history.

Unless otherwise indicated the specific electronic form of the document is copyright. Permission is granted for electronic copying, distribution in print form for educational purposes and personal use. If you do reduplicate the document, indicate the source. No permission is granted for commercial use.

© Paul Halsall August 1997
halsall@murray.fordham.edu



amazon.com



VIEW CART

WISH LIST

YOUR ACCOUNT

HELP

WELCOME

YOUR STORE

BOOKS

APPAREL & ACCESSORIES

ELECTRONICS

TOYS & GAMES

MUSIC

CELL PHONES & SERVICE

SEE MORE STORES

Search

Browse Subjects

Bestsellers

Magazines

Corporate Accounts

e-books & docs

New & Used Textbooks

Used Books

SEARCH

WEB SEARCH

Powered by A9.com

Navigation in the Age of Discovery: An Introduction

by Duane A. Cline

Availability: Usually ships within 1-2 business days

No image available

1 used & new from \$197.05

Edition: Paperback

READY TO BUY?

1 used & new from \$197.05

See all buying options

Have one to sell?

Sell yours here

Don't have one? We'll set one up for you.

See more product details

Welcome to Books! Click here to explore more.

Top Sellers in Books:



- 1. Unfit for Command by John E. O'Neill, Jerome R. Corsi
2. Jonathan Strange & Mr. Norrell by Susanna Clarke
3. Trace (Kay Scarpetta Mysteries) by Patricia Cornwell

Product Details

- Paperback: 214 pages ; Dimensions (in inches): 10.75 x 0.75 x 8.50
Publisher: Montfleury; (September 1, 1990)
ISBN: 0962721301
Amazon.com Sales Rank: 842,913
(Publishers and authors: improve your sales)

What's Your Advice?

Is there an item you'd recommend instead of or in addition to this one? Let the world know! Enter the item's ASIN (what's an ASIN?) in the box below, select advice type, then click Submit.

I recommend: in addition to this book
instead of this book

Customer Reviews

Be the first person to review this book!

Browse for books in:

- Subjects > Reference > General

BOOK INFORMATION

buying info

RECENTLY VIEWED

Search for books by subject: Reference

Feedback

 [Carry On, Mr. Bowditch](#) by Jean Lee Latham, John O'Hara Cosgrave

 [My Old Man and the Sea](#) by David Hays

 [Adrift: Seventy Six Days Lost at Sea](#) by Steven Callahan

 [Longitude: The True Story of a Lone Genius Who Solved the Greatest Scientific Problem of His Time](#) by Dava Sobel

▶ [See more in the Page You Made](#)

Featured Item:

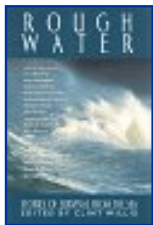

[Rough Water](#) by Clint Willis

- **I have read this book, and I want to [review it](#).**
- [E-mail a friend about this book](#).
- [Write a So You'd Like to... guide](#).
- Is there a specific product you'd like us to sell? [Tell us](#) about it.

RATE THIS BOOK

I dislike it

I love it!

1 2 3 4 5

[Edit your ratings](#)

Favorite Magazines!



Explore our new [Magazine Subscriptions store](#).

Suggestion Box

Your comments can help make our site better for everyone. If you've found something incorrect, broken, or frustrating on this page, let us know so that we can improve it. Please note that we are unable to respond directly to suggestions made via this form.

If you need help with an order, please [contact Customer Service](#).

Please mark as many of the following boxes that apply:

Product information is missing important details.

Product information is incorrect. Propose corrections using our [Online Catalog Update Form](#).

The page contains typographical errors.

The page takes too long to load.

The page has a software bug in it.

Content violates [Amazon.com's policy on offensive language](#).

Product offered violates [Amazon.com's policy](#) on items that can be listed for sale.

Comments or Examples:

Examples: Missing information such as dimensions and model number, typos, inaccuracies, etc.

Where's My Stuff?

- Track your [recent orders](#).
- View or change your orders in [Your Account](#).

Shipping & Returns

- See our [shipping rates & policies](#).
- [Return](#) an item (here's our [Returns Policy](#)).

Need Help?

- Forgot your password? [Click here](#).
- [Redeem](#) or [buy](#) a gift certificate.
- [Visit our Help department](#).





Search

for





Your Recent History

[Learn More](#)

Recently Viewed Products

-  [Carry On, Mr. Bowditch](#) by Jean Lee Latham, John O'Hara Cosgrave
-  [My Old Man and the Sea](#) by David Hays
-  [Adrift](#) by Steven Callahan
-  [Longitude](#) by Dava Sobel
-  [Celestial Navigation for Yachtsmen](#) by Mary Blewitt

Customers who bought items in your Recent History also bought:

- 
 [Adrift](#)
by Steven Callahan
- 
 [The Illustrated Longitude](#)
by Dava Sobel, William J. H. Andrewes

▶ [Visit the Page You Made](#)

Turn your past books purchases into \$\$\$
[Learn more](#) about selling at Amazon.com today!

[Top of Page](#)

[Books Search](#) | [Browse Subjects](#) | [Bestsellers](#) | [Magazines](#) | [Corporate Accounts](#)
[e-Books & Docs](#) | [Bargain Books](#) | [Used Books](#)

[Amazon.com Home](#) | [Directory of All Stores](#)

Our International Sites: [Canada](#) | [United Kingdom](#) | [Germany](#) | [Japan](#) | [France](#)

[Contact Us](#) | [Help](#) | [Shopping Cart](#) | [Your Account](#) | [Sell Items](#) | [1-Click Settings](#)

[Investor Relations](#) | [Press Releases](#) | [Join Our Staff](#)

[Conditions of Use](#) | [Privacy Notice](#) © 1996-2004, Amazon.com, Inc. or its affiliates



amazon.com



VIEW CART

WISH LIST

YOUR ACCOUNT

HELP

WELCOME

YOUR STORE

BOOKS

APPAREL & ACCESSORIES

ELECTRONICS

TOYS & GAMES

MUSIC

CELL PHONES & SERVICE

SEE MORE STORES

Search

Browse Subjects

Bestsellers

Magazines

Corporate Accounts

e-books & docs

New & Used Textbooks

Used Books

Search:

Browse:

You clicked on this item...



Taking the Stars

by Peter Ifland

Average Customer Review: ★★★★★
Usually ships in 2 to 3 weeks

Price: \$62.50



This item ships for **FREE** with **Super Saver Shipping**. [See details.](#)

From Book News, Inc.

Traces the long path of ingenious inventions developed for celestial navigation, and offers a wealth of previously unpublished color and b&w photos of instruments from private collections and maritime museums. Includes side bars on proper techniques for using various instruments described, and a... [Read more](#)

You may also be interested in these items...

Show items from:

▶ All Products

[Books](#) (4)



Secrets of the Viking Navigators

by Leif K. Karlsen

More like this



Line of Position Navigation

by Michel Vanvaerenbergh

More like this



Latitude Hooks and Azimuth Rings

by Dennis Fisher

More like this



The Fabric of the Cosmos

by Brian Greene (Author)

More like this

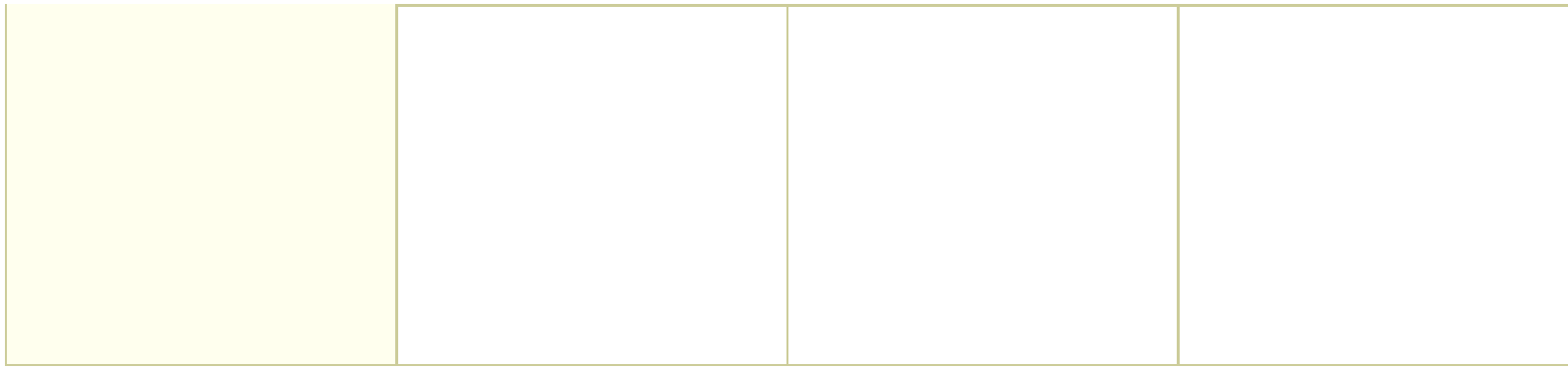

New at Amazon.com

Visit our new [Seasonal Tableware Store](#) and save up to 40% on Lenox, Spode, and more.

\$25 Off Tools & Hardware

\$25 Offer

Take \$25 off when you spend \$199 or more on [Tools & Hardware](#) products offered by Amazon.com. [Here's how](#) (restrictions apply).

New at Amazon.com



REPLACEMENTS, LTD.

Find more than 600,000 china, crystal, and silver products in the [Replacements, Ltd. Store](#).

Where's My Stuff?

- Track your [recent orders](#).
- View or change your orders in [Your Account](#).

Shipping & Returns

- See our [shipping rates & policies](#).
- [Return](#) an item (here's our [Returns Policy](#)).

Need Help?

- Forgot your password? [Click here](#).
- [Redeem](#) or [buy](#) a gift certificate.
- [Visit our Help department](#).

Search

for

Your Recent History

[Learn More](#)

Recently Viewed Products

- [Navigation in the Age of Discovery](#) by Duane A. Cline
- [Carry On, Mr. Bowditch](#) by Jean Lee Latham, John O'Hara Cosgrave
- [My Old Man and the Sea](#) by David Hays
- [Adrift](#) by Steven Callahan
- [Longitude](#) by Dava Sobel

Customers who bought items in your Recent History also bought:

- [The Bronze Bow](#) by Elizabeth George Speare
- [Johnny Tremain \(Yearling Newbery\)](#) by Esther Forbes, Lynd Ward

▶ [Visit the Page You Made](#)

Turn your past books purchases into \$\$\$
[Learn more](#) about selling at Amazon.com today!

[Top of Page](#)

[Books Search](#) | [Browse Subjects](#) | [Bestsellers](#) | [Magazines](#) | [Corporate Accounts](#)
[e-Books & Docs](#) | [Bargain Books](#) | [Used Books](#)

[Amazon.com Home](#) | [Directory of All Stores](#)

Our International Sites: [Canada](#) | [United Kingdom](#) | [Germany](#) | [Japan](#) | [France](#)

[Contact Us](#) | [Help](#) | [Shopping Cart](#) | [Your Account](#) | [Sell Items](#) | [1-Click Settings](#)

[Investor Relations](#) | [Press Releases](#) | [Join Our Staff](#)

[Conditions of Use](#) | [Privacy Notice](#) © 1996-2004, Amazon.com, Inc. or its affiliates



Shop in Health & Personal Care

(Beta-What is this?)

amazon.com



VIEW CART

WISH LIST

YOUR ACCOUNT

HELP

WELCOME

YOUR STORE

BOOKS

APPAREL & ACCESSORIES

ELECTRONICS

TOYS & GAMES

MUSIC

CELL PHONES & SERVICE



SEE MORE STORES

Search

Browse Subjects

Bestsellers

Magazines

Corporate Accounts

e-books & docs

New & Used Textbooks

Used Books

Search:

Browse:

You clicked on this item...



Emergency Navigation

by David Burch

Average Customer Review: ★★★★★

Out of Print--Limited Availability

4 used & new from \$4.99

buy used: \$4.99

Yachting

"A standout in the otherwise faceless navigation texts that pass through our offices. Anyone venturing offshore should read this book thoroughly."

You may also be interested in these items...

Customers also shopped for

Show items from:

All Products

Books (20)

Music (1)



The Sextant Handbook

by Bruce Bauer

More like this



The Complete On-Board Celestial Navigator

by George C. Bennett

More like this



Celestial Navigation for Yachtsmen

by Mary Blewitt

More like this



The Norton History of Astronomy and Cosmology (Norton History of Science)

by John North

More like this



The Extravagant Universe

by Robert P. Kirshner

More like this



Essentials of Sea Survival

by Frank Golden, Michael Tipton

More like this

	 Universe by Roger A. Freedman, William J., III Kaufmann More like this	 Storm Tactics Handbook by Lin Pardey, Larry Pardey More like this	 Celestial Navigation in a Nutshell by Hewitt Schlereth More like this
--	--	--	--





[More results](#) 

<p>New at Amazon.com Visit our new Seasonal Tableware Store and save up to 40% on Lenox, Spode, and more.</p>	<p>\$25 Off Tools & Hardware Take \$25 off when you spend \$199 or more on Tools & Hardware products offered by Amazon.com. Here's how (restrictions apply).</p> <p style="font-size: 2em; color: orange;">\$25 Offer</p>	<p>New at Amazon.com</p> <div style="text-align: center;">  </div> <p>Find more than 600,000 china, crystal, and silver products in the Replacements, Ltd. Store.</p> <p>REPLACEMENTS LTD.</p>
---	--	---

<p>Where's My Stuff?</p> <ul style="list-style-type: none"> Track your recent orders. View or change your orders in Your Account. 	<p>Shipping & Returns</p> <ul style="list-style-type: none"> See our shipping rates & policies. Return an item (here's our Returns Policy). 	<p>Need Help?</p> <ul style="list-style-type: none"> Forgot your password? Click here. Redeem or buy a gift certificate. Visit our Help department.
--	--	---

Search **for**

Your Recent History
[Learn More](#)

<p>Recently Viewed Products</p> <ul style="list-style-type: none">  Taking the Stars by Peter Ifland  Navigation in the Age of Discovery by Duane A. Cline  Carry On, Mr. Bowditch by Jean Lee Latham, John O'Hara Cosgrave  My Old Man and the Sea by David Hays  Adrift by Steven Callahan 	<p>Customers who bought items in your Recent History also bought:</p> <div style="display: flex; justify-content: space-around; align-items: flex-start;"> <div style="text-align: center;">   Secrets of the Viking Navigators by Leif K. Karlsen </div> <div style="text-align: center;">   The Bronze Bow by Elizabeth George Speare </div> </div>
--	---

[Visit the Page You Made](#)

Turn your past books purchases into \$\$\$
[Learn more](#) about selling at Amazon.com today!

[Books Search](#) | [Browse Subjects](#) | [Bestsellers](#) | [Magazines](#) | [Corporate Accounts](#)
[e-Books & Docs](#) | [Bargain Books](#) | [Used Books](#)

[Amazon.com Home](#) | [Directory of All Stores](#)

Our International Sites: [Canada](#) | [United Kingdom](#) | [Germany](#) | [Japan](#) | [France](#)

[Contact Us](#) | [Help](#) | [Shopping Cart](#) | [Your Account](#) | [Sell Items](#) | [1-Click Settings](#)

[Investor Relations](#) | [Press Releases](#) | [Join Our Staff](#)

[Conditions of Use](#) | [Privacy Notice](#) © 1996-2004, Amazon.com, Inc. or its affiliates

THE VOYAGE OF THE ICELANDER

SCHEDULE

THE CAPTAIN
& HIS SHIP

FACTS ABOUT
THE ICELANDER

THE CREW

THE VIKINGS

HARBOUR
ACTIVITIES

THE DIARY

NEWS & INFO

THE VOYAGE

SPONSORS

GALLERY

THE ESCORT
VESSEL



WHAT'S NEW

Árið 2000 fór víkingaskipið Íslendingur í sögulega ferð vestur um haf til að minnst þúsund ára afmælis Vínlandsfundar Leifs Eiríkssonar. Eftir langa fjarveru er Íslendingur loksins kominn heim. [Atómstöðinni](#) þótti við hæfi að halda upp á það með því að endurskapa vefinn sem gerður var vegna fararinnar og þakkar þeim sem hafa aðstoðað hana við það, en biðst forláts á því menn kunna að sakna.

In the year 2000, the viking ship the Icelander made a historic journey to Greenland and America to celebrate the millennium of Leif Eiriksson's journey to the New World. After a long stay abroad, the Icelander has finally come home to Iceland. To honour the Icelander's brave captain and crew, [Atomstodin](#) recreated the website made because of the journey. We thank those who have given us assistance, and apologize for any missing material.

CONTACT

LEIFUR
EIRIKSSON



1000 · 2000
The Leifur Eiriksson
Millennium Commission

Iceland
icelandnaturally.com

EIMSKIP

Click on the image below
to
see the location of the
Icelander

TrackWell

SÍMINN

www.mbl.is



SEA SCOUTS BSA



[HOME](#) · [SITE CHART](#) · [SHIPS](#)
[CONTACT US](#) · [MORE INFO](#)



Welcome!

Getting Started

- Get more information
- Events
- Local units
- Organize units
- Recruiting
- Seascout-Net
- Training
- Uniforms & supply

About Sea Scouts

- Advancement
- History
- Ideals
- Organization
- Training
- Vessels
- Welcome!

Find a Ship Near You

Advancement

- Sea Scout ranks
- Eagle Scout
- Long Cruise Badge
- Quartermaster Sea Scout
- Venturing awards

Press Coverage

Videos

Discussion Groups

- Seascout-Net
- Seascout-Europe-Net
- Regional & Flotilla bulletin boards
- e-Journals

Newsletters

- National Sea Scout Log
- Euronaut
- Seascout Fleet (UK)
- Søsprøjt (Denmark)
- The Telegraph

History

- History
- Cards
- Flags
- Insignia
- Literature
- Paintings
- Photo gallery
- Stamps

News

Mon, 6 Sept 104



June 26, 2004 --
William I. Koch
International Sea
Scout Cup Races held
on Cape Cod,
Massachusetts

[More >>](#)

January 7, 2004 -- Joining this group of scouts is
as easy as A, B, Sea

[Full Story](#)

October 11, 2003 -- Sea Scout - Coast Guard
Safety at Sea Weekend a Sell Out

[Full Story](#)

July 17, 2003 -- Set to sail -- Youth hopping on
board for Sea Scout program

[Full Story](#)

March 3, 2003 -- Sea Scouts attend the
America's Cup regatta in New Zealand.

[Full Story](#)

[All Sea Scout News](#)

Program

- Events
- Flagship competition
- Koch Cup
- Landship ceremonites
- Opportunities & activities
- Program helps
- Recruiting
- Vessels

Training

- Sea Scout Specialized
- Seabadge
- SEAL
- Seamanship training
- Venturing Leader Basic

Resources for Adults

- Adult recognition
- Forms & permits
- Organization
- Safe boating standards
- Safe Scouting Guide
- Scouting for disabled
- Training

International Sea Scouting

Downloads

- BSA forms & permits
- For Webmasters
- Images
- Presentations
- Sounds
- Text files
- Training
- Videos

Features

-  [US Power Squadrons Commits to Support Sea Scouts](#)
-  [William I. Koch Cup](#)
-  [BoatUS Opportunities for Sea Scouts](#)
-  [BoatUS National Flagship Competition](#)
-  [National Ship Name Registry](#)
-  [BSA Public Service Announcements](#)
-  [Let's Go Scouting: Spirit in action \(WOSM\)](#)

[Home](#) | [Questions?](#) | [Membership information](#) | [Site Chart](#) | [Copyright](#) | [Privacy Policy](#) | [Use of This Website](#) | [Bookmark Us](#) | [Disclaimer](#)
[Boy Scouts of America](#) | [Venturing, BSA](#)

Sea Scouts · Boy Scouts of America



<http://www.seascout.org>



THE WORLD OF THE VIKINGS

the definitive guide to viking resources on the internet

Buy the **THE WORLD OF THE
VIKINGS**
CD-ROM



[About the Project](#) [Message Board](#) [Viking Web Links](#) [Teachers Notes](#)

Welcome to The World of the Vikings

The World of the Vikings CD-ROM is a collaborative project between the National Museum of Denmark, York Archaeological Trust and over fifty museums and research institutions from across the viking world. It was produced in association with the Council of Europe, Directorate for Education and Culture by Past Forward Ltd.

This web site is maintained by Mindwave Media.

CD-ROM NOW AVAILABLE

We are pleased to announce that the VIKINGS! CD-ROM is now available for general sale worldwide via the Cambridge University Press web site.

[Visit the Cambridge website to buy online.](#)

[[Disclaimer](#)]

Viking Navigation

The beauty of Viking navigation was that it was basically so simple that there's not a lot to learn about it. This is a little general, but at least it should make a good beginning.

The quickest and best summary is still the last chapter of *The Viking* by Howard La Fey, (c) 1972, National Geographic Society, ISBN 87044-108-6, LoC 72-75383.

On the positive side, the Vikings didn't have to be anywhere at any particular time. Time, and therefore speed, was a relative function. If you were faster than another vessel, that would be noticeable, but, for the most part distances were given as "a day's sail." Purportedly, a "day's sail" for a merchant vessel was 24 hours, while that for a warship was just during the daylight hours. This may be due to the misinterpretation of how these vessels operated, with scholars supposing that the Vikings camped ashore each night like the Mediterranean-bound Greeks.

On the negative side, without a fine concept of time, there is no calculation of speed, and without both time and speed, no real accuracy in calculating distance. In other words, you can't do dead reckoning, where by keeping track of your time and speed at each change of direction, you can approximate your location. I have seen no mention of any time-keeping device, even as crude as an hour glass, in a Viking navigation context. (Come to think of it, the one time device that does stick out is Alfred the Great having a glass "hurricane cover" made for his time candle, definitely a shorebound application.) Perhaps one can count strokes when under oars for a rough estimate, but I assure you that as soon as a fair breeze sprang up, you would hoist sail; so there goes that calculation.

What the Vikings did have was decades of carefully won practical knowledge. The positions of the sun and the stars, and the experiences of previous sailors on that route. How the prevailing winds blew at certain places in certain times of the year. What the reflected loom of a glacier looked like under certain conditions, which birds and seaweed indicated a nearby island. Floki Vilgerderson, and early Norwegian settler of Iceland, went one better and took three ravens on board with him. A day or so out of the Faeroes, bound towards the recently discovered Iceland, he released the first bird, which headed back to the Faeroes. The second bird was released later and (according to which account you read) either flew up until out of sight, or came back and roosted in the rigging. Some time after that the third raven was released, flew upwards, and then headed straight for Iceland. Floki corrected his course accordingly and made a successful landfall in Iceland.

In terms of instruments:

Recent research has revealed that what appeared to be random scratches on the Greenland "bearing dial" actually mark the shadow of the sun at that latitude, enabling you to find the directions at other times other than high noon.

In the late 18th or early 19th century the sailors in the Faeroe Islands were using a wooden disk, marked with concentric circles and fitted with a moveable vertical gnomon (adjustable for the season), floating in a tub, to keep track of their latitude. This may well date from the Viking age. Sailing directions to Greenland (once the colony was well established) were, essentially, "sail west from Bergen at the same latitude until you hit Greenland."

One of our members bought a sample of cordierite, the candidate for "sunstone," but it did not perform as reported. Might have been a bad sample. I've experimented with calcite with negative results.

Before the introduction of the magnetic compass from China, the term "hafvilla" (bewildered) appears describing voyages beset by fog or bad weather. Within a few years of the introduction of the compass, the word disappears from the accounts.

One of the notes I want to mention is the Viking attitude towards voyages. In our present age, if a vessel sinks, there is a great drama enacted. Rescue vessels are dispatched. Searches are made. A board of inquiry is held, and lawsuits are launched (certainly in the United States) against those responsible or those with the deepest pockets.

In the Viking period, if your ship sunk, no one else might know about it for weeks, months, years; perhaps never. Eirik the Red set out to colonize Greenland in 986 with 25 ships. They were struck by a storm on the way, and only 14 arrived safely. The rest were either sunk or had to return to Iceland.

In another incident, a vessel was sinking off the coast of Ireland, and the "afterboat" could only hold part of the crew. After casting lots, the winning portion of the crew took to the afterboat, while the Captain, left aboard the sinking ship, loudly expressed his opinion of the unfairness of it all!

We have developed a slightly tongue-in-cheek scale of measuring the success of a voyage, but it is based on Viking attitudes. A parallel can be found at the end of the story of "Authun and the Bear":

Outstanding:

You reach your destination with ship, crew, passengers and cargo intact.

Fully Successful:

Your ship needs some repairs.

Successful:

You make it to shore with crew, passengers and cargo.

Fully Acceptable:

You get ashore with crew, passengers, and some cargo.

Acceptable:

You manage to get your crew and passengers ashore.

Marginal:

You have some survivors.

Unsatisfactory:

You are never heard from again.

In the sagas people usually make one big voyage per year, and frequently overwinter at their destination. However, one must be a little careful using saga material. It's usually equivalent to historical fiction, glorifying one's family. Basic details may be accurate, but without corroboration the facts may have been rearranged for the convenience of the author, a better story, or the fame of the family.

Piece written by Bruce Blackistone, one of the founding members of Markland and one of the founding members of the Longship Co.

Return to [Longship Home Page](#). If you have any further questions, feel free to email eowyn@wam.umd.edu.

METHODS OF NAVIGATION

| [Main Menu](#) |

While voyaging on the seas, how did the Vikings know where they were going? They didn't necessarily take the shortest routes between Norway and Greenland to avoid pack ice. Vikings did not have [compasses](#) to show direction, or instruments to tell them how far west they were sailing. They tended to stay close to land, making their way around coasts from island to island. When the men began to take the risk on the open sea, they had to know how far north or south they were from home by noting the position of the [Pole Star](#), or using a notched stick or mast of the ship to look past the star and note how far up the upright on the stick the star appeared. Later at sea, the experienced pilot could see that he was at the same [latitude](#) if the star was seen against the same mark. A higher notch meant the ship was at a higher latitude, nearer the North Pole. This method was fairly accurate on land, but how accurate was it on the rolling sea? Vikings may have used a [bearing dial](#) to determine the position of the sun and moon. Because the Pole Star was not always visible, the sun would have definitely been used during the constant daylight of the midsummer that takes place in the high latitudes of the earth. The Vikings were known to produce latitude tables for certain stars including the sun. During days of cloud cover, the crewmen could release ravens after setting sail and losing sight of land. The birds would fly to land if the ship was not too far away from shore. The Vikings would sail after birds that flew over the horizon. These seafarers would often share information with each other about what landmarks to look for and at what latitude the land could be found. In clear weather, Vikings would be able to see familiar land for 100 miles on the open sea. Another method for navigating was to observe migrating animals. The experienced sailor would use sightings of whales known to be half a day's sail south of Iceland or migrating birds such as geese to help locate land. Things could go wrong for even the most experienced pilot, however, and strong storms could blow Viking ships off course.

| [Evolution of Viking Ships](#) |

| [Main Menu](#) |

Copyright ©1996, 1997 by The Mariners' Museum

[Home](#) [Vikings](#) [Bees](#) [Rainbow](#) [History](#) [Insects](#) [Shop](#)
[Octopus](#) [Sunglasses](#) [Displays](#) [Land](#) [Naked-Eye](#) [Compass](#) [Space](#)

The Viking Sunstone

Is the legend of the Sun-Stone true ?



A Viking ship is late in its return home from the newly discovered lands far west. Winter is around the corner and the weather will soon turn ugly. It's imperative that the helmsman maintains the course due East. But where exactly is Home? The sky is becoming more cloudy every passing day. Most nights the stars are not visible and even during the day the sun has difficulty breaking through. Daylight is short and during good part the sun illuminates the sky from below the horizon . . . somewhere. Hanging from the top of the knorrship mast a sailor squints his eyes looking for clues in the brightness of the clouds . . . to no avail. Then Leif the Lucky spots an opening in the clouds. He reaches for the pouch hanging from his waist and takes out his Sunstone. Through the crystal he looks at the small patch of blue sky. He turns the rock until it becomes yellow. Next he shouts to the helmsman with his stretched arm pointing starboard . . . towards Home.

Bees do it. Ants do it. Did the Vikings do it? Can it be that the Vikings used the polarization of skylight as a navigation compass? Did the Vikings find their way to America by looking at the sky through a crystal, the proverbial sunstone?



The Icelandic sagas tell the story of how the Vikings sailed from Bergen on the coast of Norway to Iceland, continuing to Greenland and, likely, Newfoundland in the American continent. This remarkable sailing achievement was realized circa 700 -1100 AC, before the magnetic compass reached Europe from China (it wouldn't have helped much, anyway, so close to the Magnetic Pole). How did they steer true course in the long voyages out of land sight, especially in the common bad weather and low visibility of those high latitudes?

In 1967, a Danish archaeologist, Thorkild Ramskou, suggested that the Vikings might have used

the polarization of the skylight for orientation when clouds hid the sun position. They would have used as polarizers natural crystals available to them, the famous sunstones described in the sagas. To find the location of the sun they only needed a clear patch of sky close to the zenith to determine the great circle passing through the sun. The pros and the cons of this theory are the following.

In favor:

1. In the Hrafn's Saga it says: "the weather was thick and stormy . . . The king looked about and saw no blue sky . . . then the king took the sunstone and held it up, and then he saw where [the Sun] beamed from the stone."
2. The crystal cordierite can be found as pebbles in the coast of Norway. It has birefringent and dichroic properties, changing color and brightness when rotated in front of polarized light. With an adequately cleaved crystal it is easy to tell the direction of skylight polarization: its color will change (e.g. from blue to light yellow) when pointing towards the sun. [Curiously enough, the Vikings frequented Iceland, the first source of Iceland Spar (optical calcite), which has had such an important role in the discovery and study of polarization. Even today, many high-performance polarizers use that mineral]
3. At high latitude the sun remains for a long time close to the horizon, which produces the best skylight polarization pattern for navigation purposes.
4. Because of perspective, a bank of clouds of uniform density is squeezed together when looking far away. Thus, it is usually much easier to find a clear patch of sky towards the zenith (just try it). And crepuscular rays (the beams of light and darkness radiating from the sun when blocked by clouds) are difficult to see close to the zenith, as the line of sight crosses them through their thinnest section.
5. The method would have worked even when the sun was several degrees below the horizon (but still illuminating the atmosphere). Note that at twilight, when the sun is below the horizon by about two degrees, its location is very difficult to ascertain. Although a bright twilight arch can be seen, it occupies a large part of the horizon and is of uniform intensity. A similar effect may conceivably happen when the sun is above the horizon and a thick layer of clouds covers it.
6. Light fog and overcast of **thin** clouds don't eliminate skylight polarization.

Against:

1. Little detail is given to identify the sunstone and it is not mentioned specifically in relation to navigation or sailing.
2. The navigation season was, of course, summer when the sun is not that low during good part of the day nor is the weather very bad.
3. In all likelihood, the Viking sailor would have used a large number of clues from the sea

and the sky to steer his ship. In many cases he could have interpolated the position of the sun between sightings or estimated its position. Many times it suffices to look at the pattern of illumination of the clouds, their iridescence, the direction of crepuscular rays or, close to twilight, the general illumination of the sky. Furthermore, the knowledge of the sun position is not sufficient for navigation. The helmsman needed to correct the sun direction for the time of the day and day of the year. Thus, he must have been quite a good reader of the sky and the sea.

4. Under a heavy overcast sky, when a navigational aid would be most useful, the polarization method doesn't work.
5. This theory is just a possibility, a statement of what the Vikings could have done, but it is based only in circumstantial evidence.

Interestingly, in the late 40's the **US National Bureau of Standards** (now NIST) developed a Sky Compass based on the same principle. It was inspired by a previous "twilight compass" developed by Dr. A. H. Pfund of Johns Hopkins University. From a NBS 1949 paper: "The principal advantage of the sky compass . . . is during twilight, and when the sun is several degrees below the horizon, as well as when the region of the sky containing the sun is overcast, so long there is a clear patch of sky overhead. The sky compass is thus of particular value when the sun compass and the sextant are not usable. Since the extent of polarization of the sky's light is greatest at right angles to the incident beam of sunlight, the compass is most accurate in the polar regions, where it is also most useful, because of the long duration of twilight . . ." The **US Navy and Air Force** experimented with the sky compass in the 1950's and **Scandinavian Airlines (SAS)** used it for several years on its polar flights. **Polarization.com** has recently developed an inexpensive educational [Skylight Compass Card](#).



When Ramskou originally proposed this theory, it was well received and widely accepted by the general public and also by the scientific community, and remained so for more than two decades. The Viking navigational triumphs became very fashionable, especially the exploits of Eirik the Red and his son Leif (Eiricksson) the "Lucky" circa 1000 AC, and the "discovery" of America centuries before Columbus. Both, Scientific American and National Geographic magazines carried the story of skylight navigation. However, in the 90's the theory was disputed on the basis that no real material proof exists and that the advantage provided to navigation would have been marginal. My personal take is that polarized skylight could have been of real use to the Vikings but, until direct evidence is found, one should be skeptic and stick to the simplest explanation: that the Norsemen were damn good sailors!

However, the image of the Vikings in a quest of faith into mysterious and dangerous seas, following west the light from the sky viewed through a magic crystal, has its obvious romantic appeal . . .

Some references

T. Ramskou, "Solstenen," Skalk, No. 2, p.16, 1967 (Ramskou's original publication, but I haven't read it)

"Sky Compass," Review of Scientific Instruments, Vol. 20, p.460, June 1949

H. LaFey, "The Vikings," National Geographic, Vol. 137, p.528, 1970

R. Wehner, "Polarized-light navigation by insects," Scientific American, Vol. 31(1), p.106, 1976

Curt Roslund and Claes Beckman, "Disputing Viking navigation by polarized skylight", Applied Optics, Vol. 33, No. 21, p.4754, July 1994.

Bradley E. Schaefer, "Vikings and Polarization Sundials", Sky & Telescope, May 1997, p. 91

[Home](#) [Vikings](#) [Bees](#) [Rainbow](#) [History](#) [Insects](#) [Shop](#)
[Octopus](#) [Sunglasses](#) [Displays](#) [Land](#) [Naked-Eye](#) [Compass](#) [Space](#)

You are here: [NMM Home](#) / [ROG](#)

[Go back one level](#)

- [Planning a visit](#)
- [What's on](#)
- [News](#)
- [Collections & research](#)
- [Learning](#)
- [Support us](#)
- [Corporate & commercial](#)
- [Shop](#)

Search Results

You searched for **museum harrison** [[Advanced search](#)]

Found 666 results.

1 | [2](#) | [3](#) | [4](#) | [5](#) | [6](#) | [7](#) | [8](#) | [9](#) | [10](#) | [Next >](#)

1. [National Maritime Museum acquires rare papers shedding light on John Harrison and the Board of Longitude](#)

Personal papers belonging to a member of the 18th century Board of Longitude have been bought at auction by the National Maritime Museum. The papers offer new insights into the 'unofficial' views and deliberations held by Board members.

2. [Virtual tour of the Royal Observatory, Greenwich](#)



Welcome to our interactive virtual tour of Flamsteed House. The following fully-immersive 360° x 360° panoramas allow you to 'walk through' the Royal Observatory.

3. [Harrison](#)

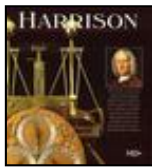

Concise biography of John Harrison by the Museum's horological expert, Harrison covers the invention of the marine chronometer 'H4', which finally solved the problem of finding longitude at sea.

4. [John Harrison and his Timekeepers at the Royal Observatory, Greenwich, tells the story of Longitude and the most important clocks ever made](#)

This August, the Royal Observatory Greenwich is launching a new documentary film, telling the dramatic story of John Harrison's search for an answer to the Longitude problem.

5. [An Historic Exhibition of John Harrison's timepieces including the most important series of clocks and watches made](#)

The earliest surviving timepiece created by clockmaker John Harrison will go on display alongside 'the most important watch ever made' in a new temporary exhibition at the Royal Observatory Greenwich. The timepieces are part of the John Harrison exhibition at the Observatory from 12 June to 14 October 2001.

1 | [2](#) | [3](#) | [4](#) | [5](#) | [6](#) | [7](#) | [8](#) | [9](#) | [10](#) | [Next >](#)

You can also search for 'museum harrison' in

our

[Prints and Drawings](#)

[Manuscripts](#)

[Historic Photographs](#)

[Search again](#)

Results from the Journal of Maritime Research

You searched JMR for **museum harrison** [[Advanced search](#)]

Found 22 results.

1 | [2](#) | [3](#) | [4](#) | [5](#) | [Next >](#)

1.



[The Wife's Tale: Frances, Lady Nelson and the break-up of her marriage](#)

In this exclusive free-access article, Colin White draws on recently-discovered letters of Frances Nelson to challenge traditional accounts of the breakdown of the Nelsons' marriage. He shows how Frances has been unfairly treated and, for the first time, tells the story from her viewpoint.

2.



[Navigation: the key to the Armada disaster](#)

Ken Douglas re-examines the traditional view of the way in which so many Armada ships arrived on the coast of Ireland, using recent research into the weather, ocean currents and Spanish navigation techniques to look for a new and logical explanation.

3.



[Understanding seventeenth-century ships' logbooks: An exercise in historical climatology](#)

Dennis Wheeler of the CLIWOC project explores the possibilities of a rich resource of historical climatology data, using the logbook of the 'Dunkirk' (1678-79) as a case study from the oldest parts of the National Maritime Museum's collection.

4.



[Sealed by Time: the loss and recovery of the Mary Rose](#)

This is the first volume of five intended to describe the excavation of the 'Mary Rose', and its subsequent raising, conservation and exhibition at Portsmouth.

5.



[Seaman Garneray](#)

Roland Wilson's new translation of the first volume of Ambroise-Louis Garneray's autobiography, first published 1851, captures the 'rattling good yarn' tone of the original.

1 | [2](#) | [3](#) | [4](#) | [5](#) | [Next >](#)

[Search again](#)



Inland Revenue Exempt Charity (No X92488). [Find out how to support the Museum's work.](#)

Home of the Prime Meridian of the World

© National Maritime Museum, Greenwich, LONDON SE10 9NF

Longitude 0° 0' 0", Latitude 51° 28' 38"

Tel: +44 (0)20 8858 4422, Recorded Information Line +44 (0)20 8312 6565

[Low graphics version](#) | [Site map](#) | [About us](#) | [Contact us](#)

ASTROLABES

MADE BY NORMAN GREENE

Each Astrolabe comes with an Astrolabe chain, an Astrolabe pouch, and a book on how to use the Astrolabe.

Call 510-524-1109 for information

or e-mail: Norm@Puzzling.net

[ORDER FORM](#)

[RETURN TO PUZZLE RING CATALOG](#)

[See the Armillary Sphere](#)



4 INCH ASTROLABE
in Gold Plate
\$135.00



4 INCH ASTROLABE
back side

The Astrolabe material is Pewter, and is available in a pewter finish or in the gold plate. It has 17 stars listed as well as a map of the sky overhead (for 37 degrees) and the ecliptic. The time of day or night is on the outside edge with noon at the top of the Astrolabe and midnight at the bottom. It comes with a carrying chain, a pouch, and a book on its use. The reverse side has a sight for measuring the elevations of the heavenly bodies.



4 inch ASTROLABE with 8 plates for adjustable latitude

Includes Birch case

Pewter finish \$245

Gold/Pewter \$285

[A List of stars on the Astrolabe and a list of the plates that are furnished.](#)

History

The Astrolabe was developed at the Greek school in Alexandria about 160 B.C. by Hipparchus. Great scientific strides forward at that time were the result of combining the Greek sciences with Babylonian mathematics. This was all made possible by the conquests of Alexander the Great who established a vast empire throughout the Mediterranean. The Astrolabe was known to scholars from then on, and was used as a slide rule of the Heavens. Direction, time, angles, and the position of the celestial bodies could all be calculated. When Prince Henry the Navigator established his seafaring fleet, he began using the Astrolabe to navigate the ships. For many years, this gave the Portuguese the exclusive ability to navigate open waters, which the other countries could not do. When Sir Francis Drake raided ports along the South American coast he was forced to flee from the Spanish ships. Drake attacked a Portuguese ship and took its Navigator hostage to guide him on his round the world voyage, thus avoiding the Spanish Fleet. All the great voyagers in the age of exploration navigated with the Astrolabe, including Columbus, Magellan, and Drake. About 1391 Chaucer wrote his Treatise on the Astrolabe for his son. All scientific texts were written in Latin, so that scholars everywhere could read them. But Chaucer's son was too young at 10 to read Latin, so Chaucer's instructions to his son became the first scientific text written in

English.



2 3/4 inch ASTROLABE

Pewter finish

\$70

This smaller Astrolabe lists 7 stars and takes its elevations with the front pointer. The map of the sky has elevations every 10 degrees, as opposed to every 5 degrees on the larger Astrolabe. It is available in the pewter finish or gold plated. It includes a carrying chain and pouch, as well as a book on its use.

THE MARINER'S ASTROLABE



5 1/2 INCH MARINER'S ASTROLABE
PEWTER FINISH
\$175

Mariners at sea confronted many problems in trying to take elevations. This adaptation has openings and is weighted at the bottom so as to be more stable with respect to wind and the motion of the ship. This style dates to around 1630 and is taken from the Astrolabe Champlain lost in the Great Lakes.

[RETURN TO PUZZLE RING CATALOG](#)

Humboldt State University → Department of Chemistry

Richard A. Paselk

Replica Instruments

A note on materials: I am an inveterate "recycler" and the materials used for the instruments I construct often reflect what I have on hand at the moment. Thus, although brass is the most common traditional metal for instruments, and has the best working/use qualities, a number of instruments are fabricated from copper because I was given a large sheet of 14 G copper. I have also used bronze (from cast plaques) because it was available, though in this case I also find it exceptionally attractive and easy to work. If you are purchasing metal brass is generally your best choice. If you are on a budget, I strongly recommend periodic trips to your local salvage yard, building up a stock of metal as you find it.

Astrolabes

Astrolabes are probably the the *sini qua non* of ancient instruments. They have been collected for centuries, and forgeries have been made for centuries, though genuine, working, astrolabes were made in Islamic countries up through the nineteenth century. For background information on astrolabes a number of books are available. Some which I have used extensively are listed among the [references](#) for this site. [The Astrolabe site](#) on the Internet provides a brief essay on the astrolabe, museums having astrolabe collections, a [history of the astrolabe](#), and finally, [astrolabe links, references, and reproductions](#), including a "personal astrolabe" available for a fee made by that site's creator.



- [Planispheric Astrolabe](#): the classic universal instrument of the Middle Ages. A complex project requiring many hours and high skill to do well.
- [Transitional Mariner's Astrolabe](#): claimed to be Christopher Columbus' own instrument. Probably derived from large wood measuring instruments used by astronomers, which were derived in turn by simplifying the planispheric astrolabe to its measurement basics. An intermediate level project, much simpler than the planispheric astrolabe, but still challenging.
- Mariner's Astrolabe: the classic form of the navigator's astrolabe as used by the Portuguese and the

Spanish in the 16th and 17th century. Somewhat more difficult than the transitional instrument above if fabricated, as here. A realistic model should be made of very heavy stock, and would be better as a casting.

Armillary Sphere



- [Armillary Sphere](#): this was a teaching/demonstration instrument representing a Ptolomaic model of the universe. Such models were characteristic of the late Middle ages and up into the 17th century. This is a difficult and time consuming project, involving fabrication with a number of different media: metal, wood, and stone.

Torquetum



- [Torquetum or turquet](#): this is a complex and sophisticated instrument characteristic of Medieval astronomy and the Ptolemaic tradition. This recreation is based on contemporary diagrams, descriptions in the literature, and the requirements for a functional instrument. It is not intended to replicate any specific instrument, but rather to be made in the spirit of the period - it could have been made by a scholar/craftsman of the 13th or 14th century. This is a difficult and time consuming project, involving fabrication and shaping of metal and wood, along with extensive scale division.

Sun Dials



- ["Canterbury" dial](#): modeled after a dial found in the walls of Canterbury Cathedral during repair work in the 1930's. Thought to be 9th or 10th century. This is a relatively simple metal project which I have done as a fabrication from bronze plate, and in a simple workshop project in aluminum. It would also be excellent as a casting.
- [Navicula, or "Little Ship of Venice"](#): Currently in progress.

Quadrant



- [Simple Quadrant](#): this is a measuring instrument used from the early middle ages through the Renaissance. Frequently other scales were added to make it into a timekeeping instrument. This is one of the least demanding of the projects listed, requiring some woodworking (or you could substitute cardboard), paper, and ink. I have also used the quadrant as a workshop project using plywood. A bronze version is in progress.

Cross Staff



- [Kamal](#): used by Arab sailors since time immemorial, this very simple instrument shares the same principle as the cross-staff, but here the cross piece is replaced by a card, and the staff by a piece of cord. This is a beginning level project, requiring little skill or time.
- [Cross staff](#): one of the most popular navigation instruments of the Renaissance and Age of Exploration, it was derived from a larger astronomical instrument invented in the 14th century. The cross-staff largely substituted for the mariners astrolabe in Northern Europe. This can be a simple or an intermediate level woodworking project. In addition to the original project illustrated, a workshop version based on half-inch dowel is also described.

Dry-Card Box Compass



- Dry-card Compass: modeled after a 13th-15th century Italian compass. This is a relatively straightforward project for those with a wood lathe and some lathe experience.

Water Clock



- Automatic Water Clock: Water clocks such as this were described by the Greeks by 300 B.C.E. They were also known to Europe in the Middle Ages. This is a fairly complex project. Depending on the materials chosen it will take intermediate to advanced skill levels to complete.



*Medieval
Science &
Scientific*

Instruments

[References](#)

[Workshops](#)

© R. Paselk
Last modified 15 May 2002

[Humboldt State University](#) → [Department of Chemistry](#)

[Richard A. Paselk](#)

The Kamal



The Kamal was used by Arab sailors since ancient times. This very simple instrument shares the same principle as the [cross-staff](#), and in fact may have been the immediate inspiration for the development of the navigational cross-staff. In the Kamal the cross piece is replaced by a card, and the staff by a piece of cord.

Of course a cord does not lend itself to fine graduations, and its design reflects the particular use of this instrument and the circumstance of Arab navigators. The Kamal was not generally used to find one's location at sea. Rather it was used to maintain a particular latitude. That is, it was used to keep on course by making sure a particular reference star remained at a specific altitude above the Southern horizon at its meridian. Thus a Kamal might have a series of knots on the cord corresponding to the latitudes of specific destinations. In fact the destinations might be written on the face of the Kamal for easy reference. The Kamal was particularly well adapted to the common situation of Arab sailors on the Indian ocean. For long journeys most sailing would follow the monsoon winds, which blow steadily in either an Easterly or Westerly direction for long periods. Thus one sails before the wind with no tacking required. To find the next port it is only necessary to keep at its latitude and you'll run into it!

The Kamal can also be used for layout. A friend uses one to measure off the distance for placing archery targets. He has made a cord such that a six foot friend just walks away until he matches the Kamal and the measurement is done. And the Kamal is easily transported - just wrap the cord around the plate and stick it in a pocket.

Kamal Cord Calibration

In making a Kamal one can determine the lengths to lay out on the cord using the same procedures used for [cross staff graduation](#). The difference is at the Kamal cord is traditionally marked out with knots instead of the marks on cross staff staffs.

Making a Kamal

This Kamal was one of the projects for my 1998 workshop, *"Medieval Scientific and Philosophical Instruments."*

Materials (provided at the workshop - illustration below):

- Wooden rectangle, 3/8" x 6" x 3", with hole drilled in center (about 3/16").
- Length of cord, about 24".



Construction:

- Sand the board to remove splinters and to give a nice finish, taking care not to change the length or width dimensions of the board.
- Thread one end of the cord through the central hole in the board and knot it so it can not slip out.
- Make additional knots in the cords at distances determined to measure desired angles with either the 6" or 3" dimension. You may use the [table of angles](#) determined for the cross-staff, or either of the layout boards described for the cross-staff to determine the appropriate lengths.
- Tie a knot at the end of the cord to keep it from fraying and you are finished.



Medieval
Science &
Scientific

Instruments

References

Instruments

© R. Paselk

Last modified 6 August 1999

Humboldt State University → Department of Chemistry

Richard A. Paselk

The Cross-Staff



The cross-staff was first described, as an astronomical tool, by the Medieval Jewish scholar Levi ben Gersohn about 1342. In order to accommodate a broad range of angles he used a long staff, and was probably aided by an assistant to move the cross-piece in taking measurements. These early cross-staffs had only a single scale. For *the* book on the cross-staff see [The Cross-Staff by Morser-Bruyns](#).

The cross-staff above is made of teak. The staff is 1/2" square stock cut from a plank and planed smooth by hand. The cross-pieces are of 1/8" x 1 1/2" sheet cut from 1" stock with a table saw and planed. They are glued and nailed to square bolsters with the edges ogee'd with a router. The 1/2" square holes were cut with a mortising machine after assembly. The staff is 32" long and graduated on the four sides from 5° - 16°, 10° - 30°, 20° - 60°, and 40° - 90°. The graduations are cut into the wood, while the figures are stamped. The graduations were determined by calculation to correspond to the cross pieces. The cross pieces are 2 1/2", 5", 10", and 20" long, corresponding to the respective scales on the staff. The eye-end of the staff is blunt while the far end is pointed, in accordance with navigational tradition (probably to enable ease of use at night).

Cross-Staff Graduation

Note that for the cross-staff the staff can be calibrated in any linear scale. The only important information is the ratio of the length of the cross-piece to the length measured on the staff! Thus one could measure both in, say, rice grains, little finger widths, fly's eyes, or whatever! Trigonometry can then be used to determine the angles at leisure. (A leisurely pace would not be uncommon in astronomy, however, it might be more trouble for rangefinding for artillery!)

For most instruments of course, one does the calculations in advance, and graduates the staff directly in degrees (note that in this case the scales will not be linear). Thus to determine the angular distance between two objects one slides the cross-piece along the staff until the two lines-of-sight just graze the ends, as shown in the illustration. The angle would then be read directly off the graduations on the staff where the cross piece intersects it.



Each line of sight forms the hypotenuse of a right triangle with the staff and cross piece as the adjacent and opposite sides, respectively. To layout the Staff then we can look at one of these triangles (which now encompass half of the observed angle) as seen below:

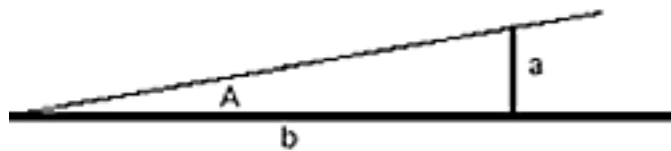

Trigonometric Calculation Method: The tangent of angle A is then $\text{Tan} = \text{opposite side}/\text{adjacent side} = a/b$. For a cross piece of given length we then have $\text{length} = 2a$, and the angle measured = $2A$, with the length along the staff equal to b . Thus $b = a/(\tan A)$. For example, to find the length to mark off along the staff for the angle 20° with a 6 inch cross-piece, we have: $b = (6/2) / (\tan 20^\circ/2) = 3 / (\tan 10^\circ)$. For the modern staff-maker this is an ideal place to utilize a spread sheet. For illustration you may check out my sample [table of angles](#) for 5 - 90° by 5° . If you are interested in setting up your own spread sheet I have provided a [table of sample calculations](#) based on Excel. If you want to make a number of cross-staffs then it is more efficient to make a layout board rather than measure the distances individually. Thus for the workshop described below I used the calculated distances at 5° intervals to make a layout board for 3" and 9" cross pieces. The board itself is 5" wide and 4' long (only about half is shown):



Geometric Method: A second way of determining the distances along the staff is the Geometric method. In this method a protractor is used to draw the various angles one is interested in on a board or card the length of the staff and the width on one half of the cross piece. The distances are then determined by the intersections of the angle lines with the edge of the board. One may now lay the staff along the board and mark off the distances for the various angles. For the workshop described below I made a board marked at 10° intervals for cross pieces of three different lengths, 3", 6", and 9". Thus there are three lines above and parallel to the center line:



The board itself is 10" wide and 4' long (only half is shown in the illustration). Both edges may be used in layout. For the 3" cross piece one looks at the intersection of the angle with the line closest to the center line (1 1/2" out = 3 x 0.5).

Copy Method: A third traditional method of calibration is to simply copy another staff. In this case one lines up the two staffs, and using a square and marking tool transfers the markings from the finished staff to the new staff. The cross pieces of the two staffs must also match.

Making a Simple Cross-Staff

This cross-staff was one of the projects for my 1998 workshop, "*Medieval Scientific and Philosophical Instruments.*"

Materials (provided at the workshop):

- Hardwood dowel, 1/2" diameter x 4' long (sight along the dowel before using it to make sure it is straight). A three foot dowel would be more realistic for use by a single individual. the four foot instrument requires an assistant for effective use of the full length, but it does allow a wider range of angle measurement.
- Cross pieces, 3/4" x 1 1/2" x 3" and 9" long, respectively. A 1/2" hole is drilled in the center of each, and the ends are chamfered for better sighting, as illustrated below:



Construction:

Lightly sand the cross pieces to remove splinters and provide a good finish. **Caution** do not change the length of the cross piece while sanding!

- Check to make sure that your cross pieces slide down the entire usable length of your dowel. A tight fit is OK - it can be waxed **after** graduation.
- You are now ready to graduate your staff.
 - Choose whether you are going to use the geometrical or calculation method.

- Line up the end of your staff with the origin of your rule or geometrical layout board. (The layout boards at the workshop have stops at the origin end - just butt the end of the staff against this ledge.)
- Take a small square and, for the calculation method line it up at the proper graduation on the scale:



Or, for the geometrical method line it up at the inter section of the angle line and cross piece line.



- Finally, mark off the distance with a ballpoint pen. If you are using two different cross pieces you may want to use different colors for the two sets of graduations.
- Once the staff is graduated you can wax it to make it operate more smoothly.
- For navigation staffs it was traditional to point the end away from the eye. This makes it easier to use at night.

[Instruments](#)



[Medieval
Science &
Scientific](#)

[References](#)

[Instruments](#)

© R. Paselk

Last modified 6 August 1999

Humboldt State University → Department of Chemistry

Richard A. Paselk

The Quadrant



The quadrant is one of the earliest and simplest of measuring instruments for astronomy, navigation, and surveying. In operation one sights an object, such as a star, through the two sighting vanes along the 90° line (right edge in picture above), while holding the quadrant in one hand, and then clamps the string against the scale with the other hand. When sighting the Sun, one lines the quadrant up such that the image of the Sun formed by the upper pinnule falls on the lower pinnule. One then clamps the string as above and reads the angle on the scale.

The instrument shown above is constructed of $1/2$ " Ash plank with a radius from tip to edge of $9\ 3/8$ ". The straight edges were cut and squared on a table saw, then the arc was rough-cut with a band saw. The straight edges were then finished with a Jack-plane, and the arc finished by hand with a Compass-plane. (I really enjoy using hand tools, but I don't have the time or patience to use them exclusively, so most of my rough work involves power tools.) To provide a better surface for drawing and writing a sheet of "parchment" paper was glued onto the wood base. The graduations, lettering etc. were then done with India ink with drafting and calligraphy pens.

The bob was hand turned on a wood lathe from $3/8$ " brass round stock with a file (careful, if it grabs you can be damaged). There is a small hole in the top for the thread, with a cross hole through the grooved part to tie it. The sites are fabricated from 12 gauge brass sheet stock with carefully centered holes. The sites have an inverted "J" profile, with the stem in the wood and the curve overhanging the parchment. This allows the holes to align over the 90° line and the thread of the plumb bob to also line up at 90° .

This quadrant has a shadow square ([discussed below](#)) as well as the graduated arc for aid in solving surveying type problems.

Making a six inch simple quadrant

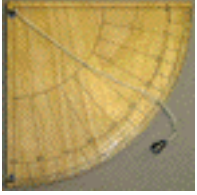

This quadrant was one of the projects for my 1998 workshop, *"Medieval Scientific and Philosophical Instruments."*

Materials (provided at the workshop - illustration below):

- 6 3/8 inch square of 1/4" plywood, cut with a band or jig saw to a quarter of a circle of 6 3/8 inch radius. Two holes are drilled along on edge to accommodate the sights, carefully aligned with the zero line of the quadrant. A third, small hole, is drilled at the vertex of the quadrant, 1/4 inch in from each edge.
- Two male spade wire connectors (with central holes) for sites. (The enlarged portion of the sleeve on the brand provided was cut off, as shown in the upper connector in the illustration below.)
- A short (7-8 inches) length of fine cord or heavy thread to suspend the bob.
- A symmetrical fishing weight for a plumb bob (a small, #1, worms head weight was used, but heavier weights will serve better with wind etc.).

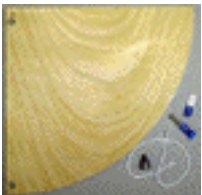

Construction :

- Lightly sand the edges and surfaces of the plywood quarter circle as necessary to remove the rough edges and splinters. The surface should be smooth enough to write on with a ball point pen (felt pens may also be used if the wood is sealed before-hand).
- Check the two straight edges of your quarter circle for square. If they are at exactly 90°, then draw straight lines parallel to each edge passing through the center of the small hole at the vertex (they should be about 1/4" in from each edge). If the two straight edges are not at 90°, draw one and then draw the second at 90° to the first. Again both should pass through the center of the vertex hole. These will be the 0° and 90° line for your quadrant. (If you wish to use classical [geometrical methods of dividing](#), then only draw one line at this time. The second will be

determined with a dividers in the process of division.)

- Next layout the arcs defining the scales. In the design here four arcs are drawn. Beginning from the outer edge, the first three are drawn using the three different beam compasses (6", 5 3/4", and 5 1/4") shown below.



- The compasses are made from hardwood, with a sharpened finishing nail for the point (it must be sharpened round, so no edges remain) inserted through a predrilled hole 3/8" from one end. The other end was made into a pen clamp by drilling two holes (one pen size about 1/2" in from the end and the other slightly larger about 3/8" further in) and then cutting a slit in from the end through the pen hole and into the other. A body hole for a wood screw is then drilled through the side up to the slot, and then a pilot hole through the remainder. A waxed wood screw is then used as a clamping screw.
- First, a 6" arc using the largest beam compass is drawn. To use this compass, place a pen in it and line up the tip so that it sticks out about 1/16" less than the nail point, and clamp it in. Now put the point into the vertex hole, and holding the beam in one hand with the pen perpendicular to the plywood, slowly turn the plywood blank under the pen to make an arc from between the 0° and 90° lines. Next, using the other two beam compasses, make the 5 3/4", and 5 1/4" arcs:

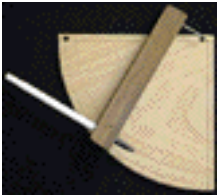

- Finally, a 3" radius arc is drawn using the edge of the 6" protractor as guide:

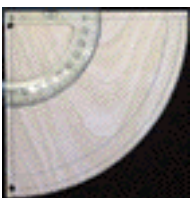

- You are now ready to layout the graduations. (At this point, you may wish to consider alternate [methods of graduating an arc](#).) I find that doing so in stages reduces my chance of error, thus:
 - First draw the graduations at 10° intervals. Using a shape pencil and your protractor make light marks every 10° (10, 20, 30, etc.) on the 3" arc. Next take your straight-edge and line it up with your 10° mark and the center of the vertex hole. Draw a line with the pen from the 3" to the 6" arc. (You may want to practice on a piece of paper or scrap wood to get the pen line to pass through the center of the marks. An old trick is to place the pen point on the mark then move the ruler up into contact with it.) Repeat with each of the other marks.
 - Beginning with the 90° line (adjacent to the site holes), label the graduation line. I wrote

mine above the 5 1/4" arc straddling each graduation.

- Next draw the graduations at 5° intervals. Again begin by making light pencil marks on the 3" arc. Then align your ruler and draw lines with the pen between the 5 1/4" and 6" arcs.
- Finally, draw the 1° graduations. This may be readily accomplished in two ways. 1) Proceed as above, graduating between the 5 3/4" and 6" arcs. 2) Use a dividers to mark four equally spaced intervals on the 6" arc, and draw graduations between the 5 3/4" and 6" arcs. Any easy way to set your dividers is to line it up at 2° intervals on the 3" arc of the protractor - this will give 1° of arc on the 6" circle.

Adding a Shadow Square. The shadow square is used to find the opposite side of a triangle when the adjacent side is known, or vice-versa. In other words it solves simple trigonometric problems based on the tangent function. If you want to layout a shadow square using angle measurements you must calculate the angles for given ratios using the arctangent function. I have provided a [table of sample values and formulae](#).

Of course the easiest way to layout a shadow square is to base it on similar triangles. Quite simply, you decide on how many divisions you want, divide the length of the side of your square by the number of divisions, and then set a dividers for that distance. You now use the dividers to lay off the required divisions. Finally, line up a straight-edge between the vertex of the quadrant or shadow square and your divisions and draw line segments.

You can add a shadow square to your six inch quadrant as follows. (Shadow squares with 12 divisions seem to be the most common. I have chosen 9 divisions for this quadrant due to the ease of layout with a mm scale.) Layout a 45° line in pencil from the vertex of the quadrant to the innermost (3") arc. Using a square or ruler draw lines to the intersection of the line with the arc perpendicular to the 0° and 90° lines. Next draw a second pair of lines parallel to and above the first pair between the 0° and 90° lines and the 45° layout line at positions where they are exactly 45 mm long. Now mark off 5 mm intervals along these lines. If you now draw lines between the parallel lines which intersect the vertex and the intervals you will create 9 trapezoidal spaces on each side. Traditionally the spaces are alternately left open and filled in, as seen in the figure.

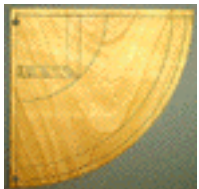



Medieval
Science &
Scientific

Instruments

References

Instruments

© R. Paselk

Last modified 6 August 1999







Astrolabes



This exercise was developed to be used at the TOPS 1995 workshop in Kamuela (by O. Hainaut and K. Meech), as an activity to get students and teachers more quickly familiar with the night sky and to easily give them the ability to plan observations. Below is a description of the astrolabe and its uses, as well as instructions on how to build one with location specific templates you can download from the web.

[Return to
Hands-on
Activities Page](#)

- [Astrolabe History and Description](#)
- [Download templates](#)
- [Assembly Instructions](#)
- [Usage Instructions](#)

[Return to
Resources](#)

An excellent site which has a lot of information about astrolabes is <http://www.astrolabes.org/>.

[Return to Main
TOPS](#)

For questions about the templates, please contact Olivier Hainaut ohainaut@eso.org, who developed them.

This website has been included in the PSIGate Physical Sciences Information Gateway, <http://www.psigate.ac.uk>, a free online catalogue of high quality Internet resources in the physical sciences. You can search PSIGate from the link provided below.

Search PSIGate, the physical sciences information gateway



This page has been visited **019123** times since October 1999.

Last Updated on May 12, 2003

Karen Meech, Institute for Astronomy, University of Hawaii

meech@ifa.hawaii.edu

The Astrolabe

An instrument with a past and a future

This page provides a very general overview of astrolabe principles. Links are provided to other pages with more details. The astrolabe in the picture was made by the French scientist and craftsman Jean Fusoris in about 1400 (*photo courtesy Adler Planetarium and Astronomy Museum*). Click on the image to display a biographical sketch of the maker and large pictures of the front (121K) and back (51K) of the instrument. You can also download [The Electric Astrolabe](#) and a template for making a [Mariner's Astrolabe](#).

NOTE: Janus has moved. Our new address is at the bottom of this page.

What is an Astrolabe?

The astrolabe is a very ancient astronomical computer for solving problems relating to time and the position of the Sun and stars in the sky. Several types of astrolabes have been made. By far the most popular type is the *planispheric astrolabe*, on which the celestial sphere is projected onto the plane of the equator. A typical old astrolabe was made of brass and was about 6 inches (15 cm) in diameter, although much larger and smaller ones were made.

Astrolabes are used to show how the sky looks at a specific place at a given time. This is done by drawing the sky on the face of the astrolabe and marking it so positions in the sky are easy to find. To use an astrolabe, you adjust the moveable [components](#) to a specific date and time. Once set, the entire sky, both visible and invisible, is represented on the face of the instrument. This allows a great many astronomical problems to be solved in a very visual way. [Typical uses](#) of the astrolabe include finding the time during the day or night, finding the time of a celestial event such as sunrise or sunset and as a handy reference of celestial positions. Astrolabes were also one of the basic astronomy education tools in the late Middle Ages. Old instruments were also used for astrological



purposes. The typical astrolabe was not a navigational instrument although an instrument called the [*mariner's astrolabe*](#) was widely used. The mariner's astrolabe is simply a ring marked in degrees for measuring celestial altitudes.

The [history of the astrolabe](#) begins more than two thousand years ago. The principles of the astrolabe projection were known before 150 B.C., and true astrolabes were made before A.D. 400. The astrolabe was highly developed in the Islamic world by 800 and was introduced to Europe from Islamic Spain (Andalusia) in the early 12th century. It was the most popular astronomical instrument until about 1650, when it was replaced by more specialized and accurate instruments. Astrolabes are still appreciated for their unique capabilities and their value for astronomy education.

Collections

The largest astrolabe collection in North America, and the best displayed in the world, is at the [Adler Planetarium and Astronomy Museum](#) in Chicago, IL. The permanent Adler exhibit, "The Universe In Your Hands: Early Tools of Astronomy," includes many of the rare and beautiful astrolabes in the Adler collection along with other pre-telescopic instruments such as sundials and armillary spheres. Other astrolabe collections in North America are at the National Museum of American History division of the Smithsonian Institution (Washington, DC) and Harvard University (Cambridge, MA).

The largest astrolabe collection on public display is at the Museum of the History of Science, Oxford, UK. Other collections in the UK are in the National Maritime Museum (Greenwich), The British Museum (London), The Science Museum (London) and the Whipple Museum of the History of Science (Cambridge).

European continental museums with astrolabe collections include Museo di Storia della Scienze a Firenze (Florence), Germanisches Nationalmuseum (Nurnberg), Conservatoire National des Arts et Metiers (Paris), Museo Naval (Madrid), Observatorio Astronomica di Roma (Rome) and the Musees Royaux d'Art and d'Histoire (Brussels).

A page with [links to other relevant web pages, reference and astrolabe reproductions](#) is attached.

A new page has been added that shows astrolabes made by [individuals](#). Please send us a note if you have made an astrolabe that you would like to have included.

We have accomplished our purpose if these few pages have satisfied or increased your curiosity about astrolabes. In an effort to make astrolabe information more accessible, we offer an inexpensive astrolabe reproduction called [The Personal Astrolabe](#). Even though there is a modest charge for [The Personal Astrolabe](#) it is not really a commercial product since it is offered at cost. If you would like to know more about astrolabes, would like to own your own astrolabe or learn more about [The Personal Astrolabe](#),

send your mailing address to **Janus** at the address below or via [e-mail](#) to receive free information.

We are now offering a free download of a planetarium program in the form of a planispheric astrolabe called [The Electric Astrolabe](#). Click on the name for a description and download and installation instructions.

Please drop us a note to let us know what you think of these pages, why you visited, how you found them, whether your needs were satisfied or just to say hello. We can handle notes in German, French or English, Italian babytalk and British (if the constructions are kept simple). We answer every single message we receive that asks a question. If you do not get an answer there must be something wrong with your e-mail return address. Try again or send us your mailing address to receive information about the Personal Astrolabe.

This page constructed by:
James E. Morrison, Janus
18 Kingsbridge Road
Rehoboth Beach, DE 19971
USA

(302) 226-5086
janus.astrolabe@att.net

In the unlikely event that anyone cares, here is a picture of the author giving an astrolabe [tutorial](#) to an eager young student.



Astronomy site of the day 9/2/96





Last updated: January 9, 2004. These pages are in a constant state of revision. Check back to see what has been added.

The Web Counter shows that this page has been accessed:

224211

times since July 5, 1996.

WEB counter™



amazon.com



VIEW CART | WISH LIST | YOUR ACCOUNT | HELP

WELCOME

YOUR STORE

BOOKS

APPAREL & ACCESSORIES

ELECTRONICS

TOYS & GAMES

MUSIC

CELL PHONES & SERVICE

SEE MORE STORES

Search

Browse Subjects

Bestsellers

Magazines

Corporate Accounts

e-books & docs

New & Used Textbooks

Used Books

Search:

Browse:

You clicked on this item...



The Sextant Handbook

by Bruce Bauer

Average Customer Review: ★★★★★
Usually ships in 24 hours

Price: \$11.17
You Save: \$4.78 (30%)

14 used & new from \$10.17



Eligible for FREE Super Saver Shipping on orders over \$25. See details.

Sailing

Or buy used: \$57.86

"This is a good book... The author writes clearly and knowledgeably."

You may also be interested in these items...

Customers also shopped for

Show items from:

All Products

Books (20)

DVD (19)

Music (4)



The Complete On-Board Celestial Navigator

by George C. Bennett

More like this



Celestial Navigation for Yachtsmen

by Mary Blewitt

More like this



Celestial Navigation in a Nutshell

by Hewitt Schlereth

More like this



Latitude Hooks and Azimuth Rings

by Dennis Fisher

More like this



The American Practical Navigator

by Nathaniel Bowditch, National Imagery and Mapping Agency Staff

More like this



Dutton's Nautical Navigation

by Thomas J. Cutler

More like this

	 Emergency Navigation by David Burch More like this	 How to Read a Nautical Chart by Nigel Calder More like this	 One Hundred Problems in Celestial Navigation, Second Edition by Leonard Gray More like this
--	--	--	--

[More results](#) 

<p>New at Amazon.com Visit our new Seasonal Tableware Store and save up to 40% on Lenox, Spode, and more.</p>	<p>\$25 Off Tools & Hardware Take \$25 off when you spend \$199 or more on Tools & Hardware products offered by Amazon.com. Here's how (restrictions apply).</p>	<p>New at Amazon.com</p>  Find more than 600,000 china, crystal, and silver products in the Replacements, Ltd. Store . REPLACEMENTS, LTD.
---	--	--

<p>Where's My Stuff?</p> <ul style="list-style-type: none"> Track your recent orders. View or change your orders in Your Account. 	<p>Shipping & Returns</p> <ul style="list-style-type: none"> See our shipping rates & policies. Return an item (here's our Returns Policy). 	<p>Need Help?</p> <ul style="list-style-type: none"> Forgot your password? Click here. Redeem or buy a gift certificate. Visit our Help department.
--	--	---

Search **for**

Your Recent History
[Learn More](#)

Recently Viewed Products

-  [Emergency Navigation](#) by David Burch
-  [Taking the Stars](#) by Peter Ifland
-  [Navigation in the Age of Discovery](#) by Duane A. Cline
-  [Carry On, Mr. Bowditch](#) by Jean Lee Latham, John O'Hara Cosgrave
-  [My Old Man and the Sea](#) by David Hays

Customers who bought items in your Recent History also bought:

- | | |
|--|---|
| 
 Secrets of the Viking Navigators
by Leif K. Karlsen | 
 The Bronze Bow
by Elizabeth George Speare |
|--|---|

[Visit the Page You Made](#)

Turn your past books purchases into \$\$\$
[Learn more](#) about selling at Amazon.com today!

[Books Search](#) | [Browse Subjects](#) | [Bestsellers](#) | [Magazines](#) | [Corporate Accounts](#)
[e-Books & Docs](#) | [Bargain Books](#) | [Used Books](#)

[Amazon.com Home](#) | [Directory of All Stores](#)

Our International Sites: [Canada](#) | [United Kingdom](#) | [Germany](#) | [Japan](#) | [France](#)

[Contact Us](#) | [Help](#) | [Shopping Cart](#) | [Your Account](#) | [Sell Items](#) | [1-Click Settings](#)

[Investor Relations](#) | [Press Releases](#) | [Join Our Staff](#)

[Conditions of Use](#) | [Privacy Notice](#) © 1996-2004, Amazon.com, Inc. or its affiliates

**UNIVERSITY OF PENNSYLVANIA MUSEUM of Archaeology and
Anthropology**
presents

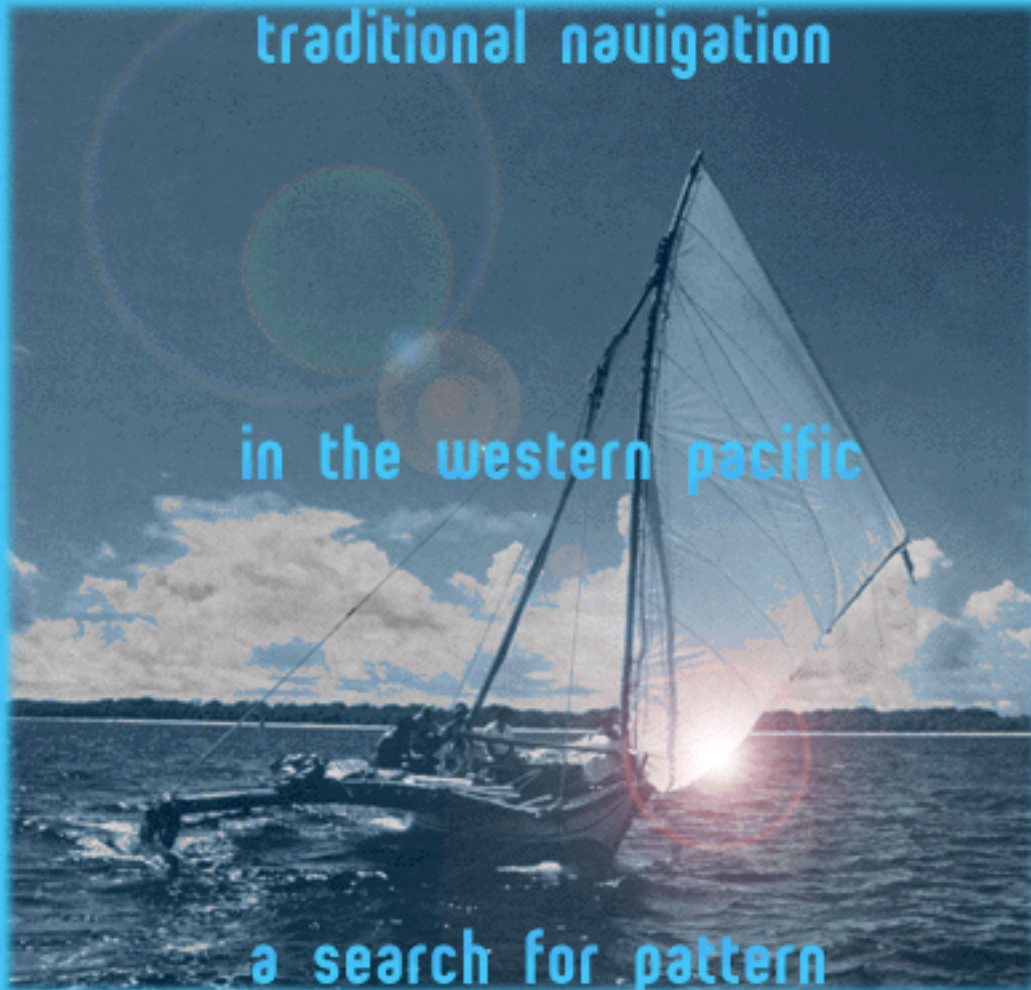

**Is there a primitive mentality essentially
different from a civilized one?**

Or do people learn and mentally organize their experience in similar ways in spite of differences in their cultures and in the content of what they have to learn?

We know that all people, if raised in the appropriate environment, prove capable of learning to speak any language and to think and operate effectively in the context of any culture. But what about different people's traditional bodies of specialized lore? Are they organized in similar ways, or not? Cognitive psychologists are interested in understanding how specialists mentally process

and store their knowledge so that they can retrieve it as needed.

Traditional navigators of the Central Caroline Islands provide a case in point. The Carolinian art of navigation includes a sizable body of knowledge developed to meet the needs of ocean voyaging for distances of up to several hundred miles among the tiny islands and atolls of Micronesia. **Lacking writing, local navigators have had to commit to memory their knowledge of the stars, sailing directions, seamarks, and how to read the waves and clouds to determine currents and predict weather.**

[index](#)

[next](#)

see more online exhibits at
[World Cultures: Ancient and Modern](#)



University of Pennsylvania Museum of Archaeology and Anthropology

©[1997](#)



The Polynesian Voyaging Society (PVS) was founded in 1973 to research how Polynesian seafarers discovered and settled nearly every inhabitable island in the Pacific Ocean before European explorers arrived in the 16th century. Some scholars have argued that the Polynesian drifted to these islands by accident; PVS set out to show that a voyaging canoe of Polynesian design could be navigated without instruments over the long, open ocean [migration routes of Polynesia](#).



Since 1975, PVS has built and launched two replicas of ancient canoes--[Hokule'a and Hawai'iloa](#)--and completed six [voyages to the South Pacific](#) to retrace migration routes and recover [traditional canoe-building](#) and [wayfinding](#) (non-instrument navigation) arts.

- [Our Vision, Mission, and Brief History](#)
- Click here to order [a Polynesian Voyaging Society T-Shirt](#).
- Help support Hokule'a and the Polynesian Voyaging Society Education Programs with [a Donation](#).

Where We Are Today...

Hokule'a Dry Dock Update: "It takes an ahupua'a to launch a canoe." Dry dock work has been completed and on Dec. 23, 2002, Hokule'a was placed back into the ocean at the Ke'ehi Marine Center and towed to Honolulu Community College's Marine Education Training Center on Sand Island, where

she was blessed. Mahalo nui loa to all the groups and individuals who came out to help during the year-long dry-dock, dedicating their time and energy to the canoe. Great job! Hokule'a is in top shape for more voyaging, including an interisland tour in the spring of 2003, with a visit (weather permitting) to Nihoa and Mokumanamana. A sail up the Northwestern Hawaiian Islands to Midway is also being planned for 2003. (Click here for [a map of the NWHI and the locations of Nihoa and Mokumanamana](#). Click here for reports and photos from [a research expedition to the Northwestern Hawaiian Islands](#) in the fall of 2000.)

Free Public Viewing and Celebration of Hokule'a, Jan. 19, 2003: To celebrate Hokule'a's return to the ocean and to thank the hundreds of volunteers and supporters of her restoration, PVS will be hosting a free family and community event from 10 a.m. to 5 p.m. at Honolulu Community College's Marine Education Training Center, 10 Sand Island Parkway Road (first right after the Sand Island bridge). Everyone is invited.

[Timeline of 2002 Drydock / Ka'iulani Murphy](#)

Drydock Photo Gallery:

Haul Out: (1) [Hokule'a lifted from the water by a crane at Ke'ehi Marine Center \(KMC\)](#); (2) [Jim Leveille driving the Marine Travel Lift](#); (3) [Paul Cobb-Adams \(left\) and Carlos Lopez discussing the next step to in hauling out the canoe; PVS leadership in the background](#); (4) [Yoshi Muraoka, the administrative director at KMC](#); (5) [Modrel Keju, KMC office staff](#).

At Pier 61: (1) [Hokule'a at Pier 61, Workshop Home of the Friends of Hokule'a and Hawai'iloa](#); (2) [Bruce, Wally, and Jerry discuss repairs](#).

Maintenance and Dryrot Repairs: (1) [Nitty Gritty--patching and sanding the hull](#); (2) [Cat Fuller standing over the open hull](#); (3) [Tim](#)

Gilliom chisels out some dry rot; (4) Russell Amimoto with Kevin San Miguel and Tim Gilliom fiberglass over the dry rot repairs; (5) Ann-Marie Mizuno sanding the railing; (6) Dry rot repair work on the starboard hull; (7) Keao Meyer preparing for the outer hull for fiberglass work ; (8) Russell Amimoto glassing the outer hull; (9) Jerry Ongais sanding the outer hull; (10) Russell Amimoto and Kawai Hoe fiberglassing; (11) Russell Amimoto working inside the hull; (12) Kawai Hoe glassing inside the hull.

Lashing: (1) Kawai Hoe, Brad Cooper and Bobby Takei pull the line tight from below while Bruce Blankenfeld and Lyle Fukumoto maintain the lashing pattern above; (2) Below deck, Catherine Fuller and Dennis Chun pull tight the lashings of the deck to the 'iako ; (3) Meanwhile, cousins Kealoha Hoe and Kawai Hoe pull tight from above; (4) More Lashing, with Liz Kashinsky, Bob Bee, Cindy Macfarlane and Sean Marrs. Hokule'a is lashed together with a couple of miles of intricate ropework, no nails or bolts!; (5) Kawai and Russell lashing one of eight 'iako, or crossbeams, that join the two hulls.

The Ocean Learning Academy (OLA) is a combined effort of the Polynesian Voyaging Society, the UH School of Ocean and Earth Science and Technology (SOEST), the Hawaii Department of Education and other community partnerships. Open to juniors and seniors from public high schools on O'ahu, this charter school program allows students to learn about Hawaii's cultural, social and natural environments through education and active ocean stewardship. Rather than learning in the traditional classroom setting of their high schools, students of the Ocean Learning Academy spend their junior and senior years taking internet courses while studying in a variety of locations such as Maunalua Bay and Kane'ohe Bay, learning about ocean tides, coastal mapping and coral reef conservation....([continued](#))

Myron Bennett Pinky

Thompson (1924-2001): Myron

B. "Pinky" Thompson, President of the Polynesian Voyaging Society and a force for the betterment of Native Hawaiians and all of Hawai'i's people for more than 30 years, passed away on Christmas day. He was 77. In addition to providing visionary leadership as the Society's president for almost two decades, he also served "as a social worker, a land use planner, a state administrator under Governor Burns, and a trustee of the Bishop Estate. He was also one of the founders of Alu Like and Papa Ola Lokahi--among many other achievements. Throughout his career he was guided by the wisdom of his ancestors, finding in his

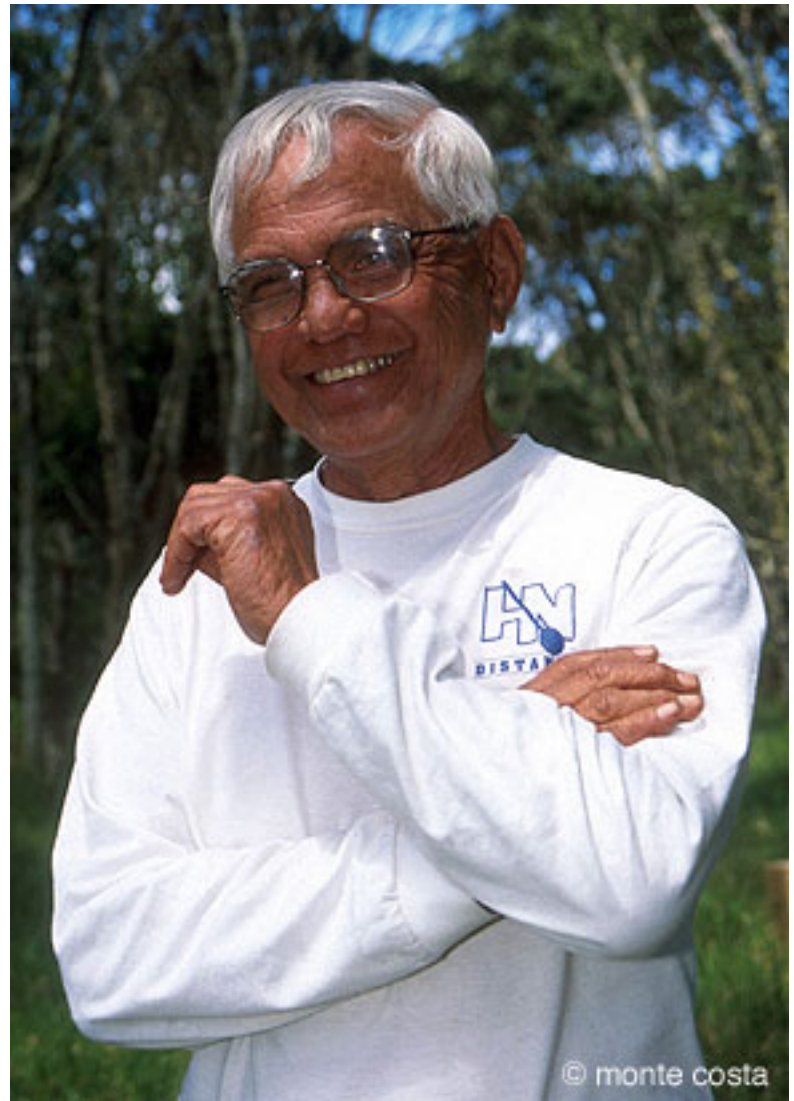

Hawaiian heritage ancient values with modern day applications." Click here for more of [Sam Low's biography of Pinky, "A Life of Service."](#) Click here for [an article on Pinky](#) by Mike Gordon of the Honolulu Advertiser (Dec. 27, 2001). Click here for [an article on Pinky](#) by Treena Shapiro and Pat Omandam of the Honolulu Star Bulletin (Dec. 26, 2001). (Photo right: Pinky at Keauhou Forest, Moku o Hawai'i, June 1999.)

Services for Pinky were held Thursday, Jan. 3, 2002, at the Bernice Pauahi Bishop Memorial Chapel on the Kapalama Campus of The Kamehameha Schools. His ashes were scattered on Saturday, Jan. 5, in Maunalua Bay.

Where We've Been ... (1) [Past Voyages of Hokule'a](#), from the daring and courageous first voyage from Hawai'i to Tahiti in 1976 to the amazing

1999-2000 voyage to Rapa Nui; (2) [Recovery of Voyaging Traditions](#); and (3) [Hokule'a's 2000-2001 Statewide Education Sail--"Our Islands, Our Canoe"](#)



What We've Learned...[Ten Themes of Learning](#); **Teacher**

Resources: (1) [Past Education Programs and Materials](#); (2) [On-Line Visuals \(Paintings, Drawings, Photos of Hokule'a; Video Clips; Maps of the Voyages of Hokule'a; Hawaiian and Micronesian Star Compasses\)](#); (3) [Bibliographies \(Books and Films\)](#); (4) [Related Websites](#).

Where We're Going...[Malama Hawai'i: A Vision for the Future](#)

This website is a service of [the Polynesian Voyaging Society](#). All writings and graphics are copyrighted by the Polynesian Voyaging Society, except those writings and graphics that are in the public domain, or those that have been used from copyrighted documents with the permission of the copyright owners.

Acknowledgements: Paintings by Herb Kawainui Kane; electronic graphics by Tim Chun; drawings by Melanie Lessett and Helene Iverson; photos by Monte Costa, Anne Kapulani Landgraf, and Doug Peebles; and by Moana Doi and other crew members of Hokule'a and Hawai'iloa.



Send comments and questions about the website to dennisk@hawaii.edu; send inquiries about the Polynesian Voyaging Society to pvs@lava.net or to Pier 7, 191 Ala Moana Blvd., Honolulu, HI 96813. Phone: (808) 536-8405; FAX: (808) 536-1519.

This site has been accessed **228317** times since June 24, 1999.



Bibliography-Wayfinding and Astronomy

Andrews, Lorrin. *A Dictionary of the Hawaiian Language*. Rutland, VT: Tuttle, 1974. (First published in 1965.)

Beckwith, Martha. *Hawaiian Mythology*. Honolulu: UH Press, 1970. (First published in 1940 by Yale University Press.)

_____. *The Kumulipo: A Hawaiian Creation Chant*. Honolulu: UH Press, 1972. (First published in 1951 by the University of Chicago Press.)

Corney, B.G. (ed.), *The Quest and Occupation of Tahiti by Emissaries of Spain during the Years 1772-6* (3 vols.), London: Hakluyt Society, 1913-1919, Vol. II, 284-287.

Finney, Ben. "Voyaging into Polynesia's Past" in *From Sea to Space*. New Zealand: Massey University, 1992.

Finney, Ben. *Voyage of Rediscovery: A Cultural Odyssey Through Polynesia*. Berkeley: University of California, 1994.

Johnson, Rubellite Kawena, and John Kaipo Mahelona. *Na Inoa Hoku: A Catalogue of Hawaiian and Pacific Star Names*. Honolulu: Topgallant, 1975.

Kane, Herb Kawainui, et al. "Steering by Stars and Seas" in *Polynesian Seafaring Heritage*, ed. by Cecilia Kapua Lindo and Nancy Alpert Mower. Honolulu: Kamehameha Schools, 1980.

Kepelino. *Traditions of Hawaii*. Edited by Martha Beckwith. Honolulu: Bishop Museum, 1932.

Kyselka, Will. *An Ocean in Mind*. Honolulu: University of Hawaii Press, 1987.

Kyselka, Will, and Ray Lanterman. *North Star to Southern Cross*. Honolulu: University of Hawaii Press, 1976.

Gladwin, Thomas. *East Is a Big Bird*. Cambridge: Harvard University Press, 1970.

Grimble, Rosemary, Grimble, Rosemary, ed. *Migrations, Myths, and Magic from the Gilbert*

Island: Early Writing of Sir Arthur Grimble. London: Routledge & Kegan Paul, 1972.

Grimble, Sir Arthur. *Tungaru Traditions: Writing on the Atoll Culture of the Gilbert Islands.* Honolulu: University of Hawai'i Press, 1989.

Lewis, David. *The Voyaging Stars: Secrets of the Pacific Island Navigators.* New York: W.W. Norton, 1978.

Lewis, David. *We, the Navigators: The Ancient Art of Landfinding in the Pacific. 2nd Edition.* Honolulu: University of Hawaii Press, 1994.

Lyman, Dave. "Pitch and Roll" in *Polynesian Seafaring Heritage*, ed. Cecilia Kapua Lindo and Nancy Mower. Honolulu: Kamehameha Schools, 1980.

Makemson, Maud W. *The Morning Star Rises.* New Haven: Yale University Press 1941.

Pukui, Mary Kawena, and Samuel H. Elbert. *Hawaiian Dictionary.* Honolulu: UH Press, 1971.

Thompson, Nainoa. Lectures, Notes, and Conversations. 1991-1998.

University of Pennsylvania. "Living Seemarks" in Traditional Navigation in the Western Pacific. 1997. <http://www.museum.upenn.edu/navigation/living/living.html>

Course Strategy and Departure Time	Holding the Canoe's Course	Compensating for Leeway	Calculating Distance	Determining Position East or West	Determining Latitude	Locating Land	Predicting Winds and Weather	Bibliography - Wayfinding and Astronomy
1976: Tahiti	1980: Tahiti	1985-87: Aotearoa (New Zealand)	1992: Rarotonga	1995: Marquesas	1995: West Coast, British Columbia, & Alaska	1999-2000: Rapanui		
Voyages	Canoe-Building	Wayfinding	Life on a Canoe	Polynesian Migrations	Proverbs and Traditions			
Home	Search	Archives	Educational Programs and Materials	On-Line Visuals	Bibliographies (Books and Films)			



Determining Position East or West of the Reference Course

The reference course which runs between the point of departure and the destination (see ["Course Strategy and Departure Time"](#)) serves as a local 0 degree longitude line against which the wayfinder can keep track of his east-west position. During the voyage, the wind will either allow the canoe to sail along the reference course, or what is more likely, the wind will push the canoe off the reference course. Thus the canoe is either on the course line (0), or a certain number of miles to the east or west of it. When the wind pushes the canoe off the reference course, the wayfinder must keep track of how far off he is.

Nainoa Thompson keeps track of deviation from the reference course in units called houses. If the canoe goes one sailing day in a direction one house to the west of the direction of the reference course, the canoe is one house to the west of the reference course; if, on the next day, the canoe goes one sailing day in a direction three houses to the east of the reference course, it would be two house to the east of the reference course. The houses east or west of the reference course are distances (not to be confused with directional houses) and can be translated into miles using a trigonometric formula for right triangles, given the distance of one leg (one sailing day = 120 miles) and one angle (one house = 11.25 degrees):

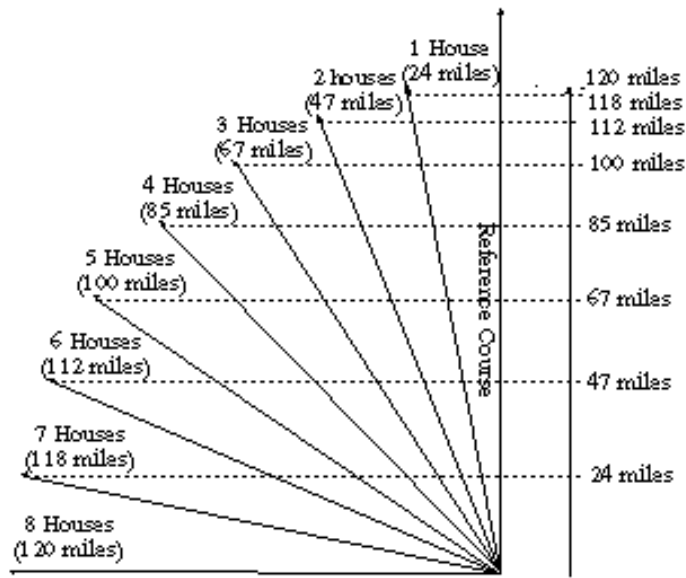

Deviation from the Reference Course
Polynesian Voyaging Society

Number of Houses / Miles
the Canoe is Off Course
after sailing one directional house off course
for an average 24-hour sailing day (120 Miles)

If the wayfinder loses track of his position in relationship to his reference course (e.g., during a prolonged storm or in prolonged cloudy conditions), he is lost; he can determine his north-south position (latitude) through observations of the stars, but he can't determine how far east or west he is along that latitude. He remains lost until some landfall (or seamark) allows him to determine his location and reorient himself. When lost, the wayfinder can look for land by tacking back and forth across an area where he thinks his destination or some other island might be located.

Course Strategy and Departure Time	Holding the Canoe's Course	Compensating for Leeway	Calculating Distance	Determining Position East or West	Determining Latitude	Locating Land	Predicting Winds and Weather	Bibliography - Wayfinding and Astronomy
	1976: Tahiti	1980: Tahiti	1985-87: Aotearoa (New Zealand)	1992: Rarotonga	1995: Marquesas	1995: West Coast, British Columbia, & Alaska	1999-2000: Rapanui	
Voyages	Canoe-Building	Wayfinding	Life on a Canoe	Polynesian Migrations	Proverbs and Traditions			

Home	Search	Archives	Educational Programs and Materials	On-Line Visuals	Bibliographies (Books and Films)
----------------------	------------------------	--------------------------	--	-------------------------------------	--



Wayfinding, or Non-Instrument Navigation

Dennis Kawaharada

Photo: Swells Help a Navigator Hold a Course in the Daytime

Introduction

Before the invention of the compass, sextant and clocks, or more recently, the satellite-dependant Global Positioning System (GPS), Polynesians navigated open ocean voyages without instruments, through careful observation of natural signs. ([See "Hawaiians as Seaman and Navigators".](#))



Navigator Nainoa Thompson of the Polynesian Voyaging Society, who was taught by Mau Piailug, a master navigator from Satawal in Micronesia, explains how a star compass is used to tell direction without instruments: "[The star compass](#) is the basic mental construct for navigation. We have Hawaiian names for the houses of the stars-the places where they come out of the ocean and go back into the ocean. If you can identify the stars, and if you have memorized where they come up and go down, you can find your direction. The star compass is also used to read the flight path of birds and the direction of waves. It does everything. It is a mental construct to help you memorize what you need to know to navigate.

"How do we tell direction? We use the best clues that we have. We use the sun when it is low on the horizon. Mau has names for how wide and for the different colors of the sun path on the water. When the sun is low, the path is tight; when the sun is high it gets wider and wider. When the sun gets too high you cannot tell where it has risen. You have to use other clues.

"Sunrise is the most important part of the day. At sunrise you start to look at the shape of the ocean-the character of the sea. You memorize where the wind is coming from. The wind generates the swells. You determine the direction of the swells, and when the sun gets too high, you steer by them. And then at sunset we repeat the observations. The sun goes down-you look at the shape of the waves. Did the wind change? Did the swell pattern change? At night we use the stars. We use about 220 stars by name-having memorized where they come up, where they go down.

"When I came back from my first voyage as a student navigator from Tahiti to Hawaii the night before he went home, Mau took me into his bedroom and said "I am very proud of my student. You have done well for yourself and your people." He was very happy that he was going home. He said, "Everything you need to see is in the ocean but it will take you twenty more years to see it." That was after I had just sailed 7000 miles.

"When it gets cloudy and you can't use the sun or the stars all you can do is rely on the ocean waves. That's why he said to me, "If you can read the ocean, you will never be lost." One of the problems is that when the sky gets black at night under heavy clouds you cannot see the swells. You cannot even see the bow of the canoe. And that is where people like Mau are so skilled. He can be inside the hull of the canoe and just feel the different swell patterns moving under the canoe and he can tell the canoe's direction lying down inside the hull of the canoe. I can't do that. I think that's what he learned when he was a child with his grandfather.

"The Southern Cross is really important to us. It looks like a kite. These two stars in the Southern Cross always point south (Gacrux on top and Acrux on the bottom). If you are traveling in a canoe and going south, these southern stars are going to appear to be traveling the higher and higher in the sky each night. If you went down to the South Pole, these stars are going to be way overhead. If you are going north to Hawai'i, the Southern Cross travels across the sky in a lower and lower arc each night. When you are at the latitude of Hawai'i, the distance from the top star (Gacrux) to the bottom star (Acrux) is the same distance from that bottom star to the horizon. That only occurs in the latitude of Hawai'i. If you are in Nuku Hiva at 9° S, the distance between the bottom star in the Southern Cross and the horizon is about nine times the distance between the two stars."

The following techniques are used by Hawaiian and Polynesian navigators taught by Mau and Nainoa. The art, as it is practiced today in Hawai'i, uses a Hawaiian star compass developed by Nainoa, incorporating principles from Mau's Micronesian star compass and traditional Hawaiian names for directions and winds.

The Sun

The sun is the main guide for the navigator without instruments. Twice a day, at sunrise and sunset, it gives a directional point to the traveller, as it rises in the east and sets in the west. The exact direction changes during the year. As the earth, tilted at at 23.5° angle, orbits the sun, the sun appears to move in the sky against the background of the stars along a curving path called the ecliptic and through a series of 12 constellations called the zodiac. (See "The Ecliptic".) At the spring and fall equinoxes (Mar. 21 and Sept.23) the sun appears to be on the celestial equator and rises due east and sets due west. During the summer, the sun is north of the celestial equator, rising and setting north of east and west; at summer solstice (June 21), the sun rises 23.5° north

of east ('Aina Ko'olau, or ENE) and sets 23.5° north of west ('Aina Ho'olua, or WNW). During the winter, the sun is south of the celestial equator, rising and setting south of east and west; at winter solstice (Dec. 22), the sun rises at 23.5° S of east ('Aina Malanai, or ESE), and sets 23.5° S of west in 'Aina Kona (WSW).

[Click here for a Diagram of the Rising and Setting Points of the Sun.](#)

To hold a course, the navigator aligns the rising or setting sun to marks on the railings of the canoe. There are 8 marks on each side of the canoe, each paired with a single point at the stern of the canoe, giving bearings in two directions, 32 bearings in all to match the 32 directional houses of the Hawaiian star compass.

[Click here for a Diagram of the 32 Bearings Marked onto the Canoe Rails.](#)

The Stars

Like the sun, most stars rise in particular directions on the eastern horizon, travel across the sky, and set in particular directions on the western horizon. The directional house in which a star rises on the Hawaiian Star Compass has the same name as the house in which it sets (e.g., a star rising in 'Aina of the Ko'olau quadrant (ENE), sets in 'Aina of the Ho'olua quadrant (WNW). The directional point at which a star sets is at the same angular distance (delincation) and in the same direction (i.e., north or south) from west as the house in which it rose is from east. For example, at the equator, Hokulei (Capella) rises at 46° N of east in Manu Ko'olau (NE) and sets at 46° N of west in Manu Ho'olua (NW).

[Click Here for the Rising Points of the 21 Brightest Stars.\)](#)

The navigator holds his course by orienting his canoe to these rising and setting points. For example, when the navigator with a favorable wind wants to head Manu Malanai (SE), and a star is rising at the point Manu Malanai (SE), he points the bow toward the star. If there is no star rising or setting in the direction he is heading, the navigator can orient the canoe using a star rising or setting anywhere else on the horizon, as long as he knows its direction. He keeps the star at a bearing that will head the canoe in the desired direction.

[Click here for a Diagram of Steering by the Stars.](#)

As wind drift may be carrying the canoe to the right or left of its apparent heading, the navigator corrects his steering for this sideway drift, called leeway ; as the night passes and stars rise and set, moving about 1 degree across the celestial sphere every four minutes, the navigator uses as many stars as possible as clues to hold his direction.

If the star is above the horizon, the navigator imagines a line from it down to its rising or setting point. The angles at which the stars rise and set will change with latitude. Only at the equator do stars appear to rise perpendicular to the horizon. In Hawai'i, at 20° N, stars rise and set at a 20° angle, leaning south from straight up; in Tahiti, at 17° south, stars rise and set at a 17° angle, leaning north from straight up. In other words, the angle at which stars rise and set from a line perpendicular to the horizon is equal to the latitude of the observer. The pathways of the stars lean south in the northern hemisphere and north in the southern hemisphere.

As the navigator moves north or south of the equator, the rising and setting points will begin to shift north for stars north of east and west and south for stars south of east and west. The shift will be smaller for stars near the celestial equator, and greater for stars toward the north and south celestial poles. (This shifting is due to the changing angle of the curved surface of the earth over which the observer sees the sky.)

As the observer moves toward the poles, the angles of rising and setting of the stars will tilt closer and closer to the horizon until at the poles, the stars will not rise or set, but circle around the observer like figures on a merry-go-round, with the observer standing in the middle. At the north pole, only the northern half of the celestial sphere is visible; at the south pole, only the southern half of the celestial sphere is visible.

A star which angles as it arcs through the sky is useful for determining direction when it is within 30-35 ° of the horizon; beyond this it becomes difficult to tell exactly where it rose or will set. At the equator, where stars rise perpendicular to the horizon, a star may be traced back to the horizon from a greater altitude.

During a voyage, stars may be available for navigation only about 20 percent of the time; daylight and cloud-cover at night hide them from the navigator during the other 80 percent of the time.

North and South Pointers

Pairs of stars that cross the meridian at the same time are oriented north and south. (The meridian is an imaginary line from due north to due south passing through the zenith, the point in the sky directly overhead; the meridian is perpendicular to the horizon; stars move from east to west through the sky and cross the meridian at the midpoint of their journeys from horizon to horizon.) Meridian pairs, or pointers, in the northern sky point north; pairs in the southern sky stars point south. For example, the top and bottom stars in the Southern Cross, a meridian pair, point south when the Cross is upright.

Meridian Pointers to the North Celestial Pole

- Alpheratz (00h 8.4m) + Polo'ula / Caph (00h 9.2m)
- Alpha Trianguli (01h 53.1 m) + Segin (01h 54.4m)
- Theta Aurigae (05h 59.7m) + Menkalinan (05h 59.5m)
- Puana / Procyon (07h 39.3m) + Nanamua / Castor (07h 34.6 m) & Nanahope / Pollux (07h 45.3 m)
- Hikulua / Merak (11h 1.8 m) + Hikukahi / Dubhe (11h 3.7m)
- Cor Caroli (12h 56m) + Hikulima / Alioth (12h 54m)
- Ed Asich (15h 24.9m) + Pherkad (15h 20.7m)
- Gienah (20h 46.2m) + Pira'etea / Deneb (20h 41.4m)
- Markab (23h 2.8m) + Scheat (23h 3.8m)

Meridian Pointers to the South Celestial Pole

- Mirzim (06h 27.7m) + Ke Ali'i o Kona i ka Lewa / Canopus (06h 23.9m)
- Suhail (09h 08m) + Star in the False Cross (09h 11m)
- Cross Dividers: Mu Velorum (10h 46.8m) + Unnamed star cluster (10h 46.3m)
- Hanaiakamalama / Southern Cross: Kaulia / Gacrux (12h 31.2m) + Ka Mole Honua / Acrux (12h 26.6m)
- Menkent (14h 6.7m) + Mailemua / Beta Centauri (14h 3.8m)
- Alpha Lupi (14h 41.9m) + Mailehope / Alpha Centauri (14h 39.6m)
- Top stars in Kamakau / Scorpio: Dschubba (16h 0.3m) + Pi Scorpii (15h 58.8m)
- Middle stars in Kamakau / Scorpio: Epsilon Scorpii (16h 50.2m) + Mu2 Scorpii (16h 52.3m) + Zeta Scorpii (16h 54.6m)
- Bottom stars in Kamakau: Kamaka / Shaula (17h 33.6m) + Sargas (17h 37.3m)

The Moon

Like the sun, the moon travels along the path called the ecliptic; however, it completes its cycle in 29.5 days—the time it takes for the moon to orbit the earth. (See "The Moon Along the Ecliptic.") The moon rises about 48 minutes later each night at a different position on the eastern horizon from where it rose the night before. Its rising point moves back and forth between 'Aina Ko'olau (ENE) and 'Aina Malanai (ESE) during its 29.5 day orbit around the earth; its setting point between 'Aina Ho'olua (WNW) and 'Aina Kona (WSW). As it changes its position in relationship to the sun and earth, it goes through 29-30 phases.

The Hawaiian Lunar Month

In the traditional Hawaiian calendar, the lunar month was determined by the 29.5-day cycles of mahina, the moon, and the passage of days were marked by the phases of the moon. The approximately 30 days of the moon cycle were divided into three 10-day periods (anahulu). The first 10-day period was called "ho'onui," "growing bigger."

1. Hilo (faint thread; cf. puahilo, "faint, wispy").
2. Hoaka (crescent; arch over the door; Handy and Handy say the name means "faint light" or "casting a shadow.")
- 3-4-5-6. Kukahi, Kulua, Kukolu, Kupau (Literally, First, Second, Third, and Last Ku)
- 7-8-9-10. 'Olekukahi, 'Olekulua, 'Olekukolu, 'Olekupau (Literally, First, Second, Third, and Last 'Oleku. 'Olekulua was the first quarter of the moon; the names for days 7-10 match the names of days 21-24 of the last quarter moon; days 7-10 mark the transition from less than half-lit moon to the more than half-lit moon.)

The second 10-day period was called "poepoe," "round" or "full," when the moon appears full and round. The nights of the bright moon-possibly Akua, Hoku, and Mahe-a-lani- were referred to as "na po mahina konane"; konane means "bright moonlight."

11. Huna ("to hide"; when the moon hides its "horns" and appears more rounded)
12. Mohalu ("to unfold like a flower," "to blossom")
13. Hua (fruit, egg)
14. Akua (god; the first night of fullness)
15. Hoku (the second night of fullness; if the moon is still out at sunrise, it is called Hoku ili, "Stranded moon"; if it has set just before sunrise, it is called Hoku palemo, "sunken moon.")
16. Mahe-a-lani (the third night of fullness; "mahea" means "hazy, as moonlight")
17. Kulua (E.S. Craighill Handy, with Mary Kawena Pukui, gives this day name as "Kulu," which could mean "to drop" or "to pass, as time does")
- 18-19-20. La'aukukahi; La'aukulua; La'aukupau (Literally, First, Second, and Last La'auku; during this sequence, the sharp "horns" of the moon begin to appear again.)

The third 10-day period was called "'emi," "decreasing" or "waning." The moon begins to lose its light. The last quarter moon rises around midnight and sets around noon. Muku, the new moon, is unseen between the earth and the sun.

- 21-22-23. 'Olekukahi; 'Olekulua; 'Olekupau (Literally, First, Second, and Last 'Oleku;

'Oleku^lua was the last quarter; the names of days 21-23 match the names of 7-10 days of the first quarter moon, and mark the transition from more than half-lit moon to less than half-lit moon.);

24-25-26. **Kaloakukahi**; **Kaloakulua**; **Kaloapau** (Literally, First, Second, and Last **Kaloaku**;

27. **Kane**

28. **Lono**

29. **Mauli** ("ghost," "spirit"; **Malo**: "fainting"; **Kepelino**: "last breath")

30. **Muku** ("Cut-off." The new moon; the end of the moon cycle. The moon is in front of the sun; its backside is lit; its frontside, facing the earth, is dark.)

Determining the rising and setting points of the moon each night in relationship to another celestial body allows the moon to be used for navigation, day or night.

The line separating light and dark on the moon's surface is aligned approximately north and south since the moon is positioned east or west of the sun as they travel across the sky.

Hoku hele / "Traveling Stars" (Planets)

Planets ("Wanderers") appear to move among the fixed stars over time; hence, their Hawaiian names **hoku** hele, "Traveling Stars", or **hoku** 'ae'a, "Wandering Stars." Their rising and setting points can be determined from nearby stars; they can be used for navigation once their positions have been determined. The Hawaiian names for the visible planets are:

Mercury: **Ukaliali'i** ("Following the chief," i.e. the Sun)

Venus: **Hokuloa** ("Long Star"), **Hokuao** ("Morning Star"), **Hokuahiahi** ("Evening Star"), **Hokuali'i** ("Chiefly Star"), **Hokuali'iwahine** ("Chiefly [female] Star")

Mars: **Hoku'ula** ("Red Star"), **Holoholopina'au**, **'Aukelenuiaiku** ("Great travelling swimmer, son of Iku")

Saturn: **Makulu** ("A drop of mist")

Jupiter: **Aohoku** ("Starlight"), **'Iao** ("Dawn"), **Ikaika** ("Strong," "Powerful")

Ocean Swells

During midday and on cloudy nights when celestial bodies are not available at the horizon as directional clues, the navigator uses the wind and swells to hold a course. However, the direction of wind and swells cannot be determined independently; their direction can only be determined by reference to celestial bodies such as the rising or setting sun.

Swells are waves that have travelled beyond the wind systems or storms that have generated them, or waves that persist after the generating storm has died away. Swells are more regular and stable in their direction than waves. ("Waves," as opposed to "swells," are generated by local, contemporary winds.) Sometimes swells can be felt better than they can be seen, having flattened out after travelling long distances. In the Pacific, the northeast trade winds generate a northeast swell; the southeast tradewinds create a southeast swell, and so on. Storms in the South Pacific during the Hawaiian summer generate a south swell; storms in the north Pacific during the Hawaiian winter generate a north swell.

Swells move in a straight line from one house on the star compass to a house of the same name on the opposite side of the horizon, 180° away. Thus, a swell from the direction of Manu Ko'olau (NE) will pass under the canoe and head in the direction of Manu Kona (SE); a swell from 'Aina Malanai (ESE) will pass under the canoe and head in the direction of 'Aina Ho'olua (WNW).

The navigator can orient the canoe to these swells. For example, if the canoe is heading SE Manu with a swell coming from the SE Manu, the person steering keeps the canoe headed directly into the swell, which lifts the bow, passes beneath, then lifts the stern. If the canoe is travelling SW, a SE swell would roll the canoe from side to side, lifting first the port hull, then the starboard hull as it passes beneath. (See ["Steering by the Swells."](#))

After the navigator orients the canoe to a swell pattern, he gets used to the pitching, rolling, or corkscrewing of the canoe; when the motion changes the navigator knows that the canoe is no longer going in the same direction (assuming the direction of the swell remains constant). The motion gets complex when more than one swell is running; an experienced traditional navigator like Mau can feel as many as four or five swells.

Swells may change direction after a time because the storm generating them may be moving. In places such as the doldrums, the swell pattern can be confused by waves generated by variable local winds from isolated and passing squalls. When the seas are confused, navigation by ocean swells is difficult.

Winds

The direction of the wind can be used to hold a course—the person steering simply holds the wind at a constant bearing to the canoe. However, the wind may change directions during the day (it is

less stable than swells), so the direction of the wind must be checked frequently against rising or setting celestial bodies and the ocean swells. ([See "An Account of Tahitian Navigation".](#))

Landmarks

On coastal voyages, a navigator can steer by landmarks. Lining up two landmarks (e.g. a hill and a mountain) allows him to hold a straight line. Two pairs of landmarks allow him to find a spot, such as a deep-sea fishing ground, where the two lines intersect. One can also navigate by knowing the shape of reefs or underwater topography which can be seen from the surface. While leaving an island for the open ocean, the navigator backsights on the island, lining up two landmarks to hold his desired direction.

Seamarks

On the 1992 *Hokule'a* voyage from Hawai'i to Tahiti, Mau Piailug shared with navigator Shorty Bertelmann a seamark he had remembered from previous voyages along the route: Mau told Shorty to look for a school of porpoises; it would indicate that he had reached a point around 9 ° N latitude on the route to Tahiti. Bertelmann sighted the porpoises at around 9 ° N, confirming for him that he was on course and solidifying his faith in the traditions of Pacific navigation.

In Micronesia, these living seamarks are called "aimers" and are "purported to be associated with particular locales in the vicinity of islands or midway between them. They comprise such things as a tan shark making lazy movements, a ray with a red spot behind the eyes, a lone noisy bird, a swimming swordfish, and so on. Each of these phenomena has its own individual name and is located within a particular 'drag' on a particular star course from its associated island. on the long course from Puluwat to Eauripik there is said to be a row of whales, each situated a day's sail directly south of an island. Each whale has its own distinctive characteristic" (University of Pennsylvania).

Grimble notes that Gilbert Island navigators also have a tradition of seamarks: "As Europeans use landmarks, so the Gilbertese [navigators] use seamarks to check their daily position. These signposts in mid-ocean consist of swarms of fish, flocks of birds, groups of driftwood, or conditions of wave and sky peculiar to certain zones of the sea. Hundreds of such traditional betia [seamarks] were stored up in the race memory as a result of cumulative experience of generations" (Grimble, *Tungaru Traditions* 48). These seamarks are found along routes between islands and indicate to the navigator that he was at a certain point along his route. For example, the seamark called "the swarming of beasts" consisted of an extraordinary number of sharks" and indicated the canoe was "a day's sail downwind of land." Other marks include a region where flying fish leaped in pairs, a zone of innumerable jellyfish, an area of numerous terns, an area of sharks and numerous red-tailed tropic birds, a place marked by a school of porpoises, a place

where pairs of porpoises point their heads "in the direction of the passage into Tarawa lagoon" (*Tungaru Traditions* 49-50).

Signs of Landfall

Once the canoe is in the vicinity of its destination according to the navigator's dead reckoning and latitude measurements, the navigator starts looking for land.

Navigating without instruments is not a precise science. Poor weather and mental lapses on a long voyage adversely affect its accuracy. But the navigator need not sail to a destination with pinpoint accuracy to be successful. Instead, the navigator in the Pacific tries to hit a "screen" of islands, that is, a group of islands that stretches out on either side of his destination. The longer or wider the screen, the less likely the navigator will miss it. Islands in the Pacific are seldom isolated; they are usually found in clusters. The Tuamotu Archipelago stretches 550 miles north to south and 500 miles east to west; the Society Islands stretches 160 miles north to south and 310 miles east to west; the Hawaiian islands extend more than a 1000 miles across the ocean east to west; the major islands form a north-south screen of about 240 miles.

While sailing to Tahiti from Hawai'i, the navigator can target a 400-mile wide screen of islands between Manihi in the western Tuamotus, and Maupiti in the eastern Society Islands. If the navigator can hit any one of the islands in this target screen, he can reorient the canoe after he identifies the island and determines its position in relationship to his destination; if he does not recognize the island and the island is inhabited, he can ask the islanders where he is and if possible, get directions to his destination.

While there are open-ocean gaps between islands in a screen, a navigator looks for signs to let him know the proximity and direction of land even when he cannot see it. Signs of land include drifting land vegetation; clouds piled up over islands; the loom above an island created by sunlight or moonlight reflecting up from the white sand and smooth water of a lagoon; distinctive patterns of swells created by swells refracting around and / or reflecting off islands; and seabirds.

Land-Based Seabirds

Seabirds such as the manu-o-Ku (white tern) and the noio (noddy tern) go out to sea in the morning to feed on fish and return to land at night to rest.

The diurnal flights of such birds are the most useful signs for expanding landfall, since their flights to and from an island gives a fairly specific direction to the navigator. As the birds leave an island in the morning, the navigator can sail in the direction the birds are coming from to find land; as the birds rise up from fishing and return to an island in the late afternoon, the navigator can follow the birds to land.

During nesting season, the habits of birds change. Nainoa Thompson tells this story about his first voyage to Tahiti in 1980-2400 miles navigated without instruments: "We saw two birds after the 29th day and I was extremely relieved. At least we were in the ball park. The birds rose up high and flew away, and we sailed in that direction; at night we couldn't see the island so we took the sails down and waited. The next morning, we looked for the birds to see what direction they were coming from and that would be the direction of the island. We waited for the first bird. All hands on deck. Not a single bird. I began to worry-it was my first voyage, and I was unsure of myself. Mau Piauug was very calm and didn't say anything. We waited and we waited. The canoe was just sitting in the water, facing south. One of the canoe members was at the back of the canoe and a bird flies right over his head. The night before that we saw the birds flying south so how come late in the morning with the sun very high was this bird coming out of the north? That would suggest that we passed the island during the night. In my panic, I thought we had better start sailing back in that direction to find the island before the sun goes down again. We turned the canoe around. But when I started to sail north Mau, who has always said that his greatest honor would not be as a navigator but as a teacher, came to me and said, "No." It was the first time that he interrupted the trip. He said, "turn the canoe around and follow the bird." I was really puzzled. I didn't know why. He didn't tell me why. But we turned the canoe around and now we see other birds flying also. Mau said, "you wait one hour and you will find the island you are looking for." And after about an hour, Mau, who is about twenty years older than me-my eyes are physically much more powerful than his-he gets up on the rail of the canoe and says: "The island is right there." And we all stood up and we climbed the mast and everything and we just couldn't see it. Vision is not so much about what you do-but how you do it. It's experience. Mau had seen in the beak of the bird a little fish and he knew that the birds were nesting. They had flown out to sea before sunrise and were taking food back at mid-morning to feed their young, before they flew out to sea again to feed themselves."

A low atoll with coconut trees can be seen at sea from about 7 -10 miles away; observing the daily flight patterns of seabirds can indicate the direction of islands far out of the range of sight. Thompson gives the following estimates of ranges of two seabirds that are the most reliable indicators of land:

manu-o-Ku (fairy tern): 120 miles (though this bird may stay out at sea, or fly back to land unseen at night)

noio (noddy tern): 40 miles

Generally, sighting of large groups of birds are more reliable signs of islands than one or two birds stray birds or small groups. ([See "How the Wayfinder Locates Land."](#))

Course Strategy and Departure Time	Holding the Canoe's Course	Compensating for Leeway	Calculating Distance	Determining Position East or West	Determining Latitude	Locating Land	Predicting Winds and Weather	Bibliography - Wayfinding and Astronomy
1976: Tahiti	1980: Tahiti	1985-87: Aotearoa (New Zealand)	1992: Rarotonga	1995: Marquesas	1995: West Coast, British Columbia, & Alaska	1999-2000: Rapanui		
Voyages	Canoe-Building	Wayfinding	Life on a Canoe	Polynesian Migrations	Proverbs and Traditions			
Home	Search	Archives	Educational Programs and Materials	On-Line Visuals	Bibliographies (Books and Films)			



Hawaiian Star Compass

Developed by Nainoa Thompson, Based on the Micronesian Star Compass of Mau Piailug



Click here for [a color Hawaiian Star Compass](#). Click here for [a black and white Hawaiian Star Compass](#).



Click here for [Mau's Star Compass](#).

To help him orient the canoe to the rising and setting points of stars, the wayfinder uses a **star compass** with thirty-two equidistant directional points around the horizon, each point 11.25 degrees from the next point (11.25 degrees x 32 points = 360 degrees). Each point is the midpoint of a house of the same name, and each house is 11.25 degrees wide (11.25 degrees x 32 houses = 360 degrees).

The four cardinal directions have traditional Hawaiian names:

East is called Hikina ("Arriving" or "Coming"), where the sun and stars "arrive" at the horizon;

West is called Komohana ("Entering"), where the sun and stars "enter" into the horizon;

North is called 'Akau;

South is called Hema.

The four cardinal directional points divide the circle of the horizon into four quadrants, which have been given names associated with wind directions:

Ko'olau is the NE quadrant, named for the windward side of the islands, the direction from which the NE trades, the most constant of the Hawaiian winds, blow.

Malanai is the SE quadrant, named for "a gentle breeze" (PE) associated with Kailua O'ahu (SE part of the island) and Koloa, Kaua'i (S by E part of the island); on a wind map of Pukapuka, two "Malangai" winds blow from the SE.

Kona is the SW quadrant, named for the leeward side of the islands, away from the NE trades; winds blowing from the south or SW are called kona.

Ho'olua is the NW quadrant, named for a strong north wind, generated by storm systems passing north of the islands. (The Pukui-Elbert dictionary gives Kiu as the name of a northwesterly wind.)

Each quadrant contains seven directional points and houses with the following names. The names were devised by Nainoa Thompson, the first Hawaiian in over 500 years to practice long-distance, open-ocean navigation without instruments:

La: "Sun"; the sun stays in this house for most of the year as it moves back and forth between its southern limit at the Tropic of Capricorn (23.5 degrees S) at Winter Solstice to its northern limit at the Tropic of Cancer (23.5 degrees N) at Summer Solstice.

'Aina: "Land"; This house between 17 degrees and 28 degrees on the horizon from east and west can be remembered because Hawai'i ('Aina, or Land) is at 21 degrees N latitude and Tahiti ('Aina, or Land) is at 18

degrees S latitude.

Noio: named for the Hawaiian tern, which helps a navigator find islands because it flies out to sea in the morning to fish (range about 40 miles) and returns to land at night to rest.

Manu: "Bird"; the four houses of Manu, midway between the four cardinal directions, can be seen as the points of the beak, tail, and outstretched wing-tips of a bird; the bird is the traditional Polynesian metaphor for the canoe. On early voyages to Tahiti, the Hokule'a sailed in the direction of Manu Malanai, with its wings and Manu Ko'olau and Manu Kona, and its tail pointed back at Manu Ho'olua.

Nalani: Named for the brightest star in this house, Ke ali'i o kona i ka lewa (Canopus), which rises in Nalani Malanai and sets in Nalani Kona.

Na Leo: "The Voices," referring to the voices of the stars speaking to the wayfinder.

Haka: "Empty"; named for the relatively empty skies around the north and south celestial poles; Kamakau say the names of these areas are Uliuli ("deep, dark blue") and Lipo ("deep, dark night").

(Information about the name of these houses is from Will Kyselka's Ocean in Mind 96-97).

Seven directional houses in each of the four quadrants combine to give 28 compass directions between the four cardinal points:

La Ko'olau = E by N

'Aina Ko'olau = ENE

Noio Ko'olau = NE by E

Manu Ko'olau = NE

Nalani Ko'olau = NE by N

Na Leo Ko'olau = NNE

Haka Ko'olau = N by E

La Ho'olua = W by N

'Aina Ho'olua = WNW

Noio Ho'olua = NW by W

Manu Ho'olua = NW

Nalani Ho'olua = NW by N

Na Leo Ho'olua = NNW

Haka Ho'olua = N by W

La Malanai = E by S

'Aina Malanai = ESE

Noio Malanai = SE by E

Manu Malanai = SE

Nalani Malanai = SE by S

Na Leo Malanai = SSE

Haka Malanai = S by E

La Kona = W by S

'Aina Kona = WSW

Noio Kona = SW by W

Manu Kona = SW

Nalani Kona = SW by S

Na Leo Kona = SSW

Haka Kona = S by W

A star that rises in a house on the NE horizon travels across the sky, and sets in a house of the same name on the NW horizon; A star that rises in a house on the SE horizon travels across the sky, and sets in a house of the same name on the SW horizon. Thus, the rising and setting points of stars are clues to direction.

Recognizing a star as it rises or sets and knowing the house it rises or sets in gives you a directional point by which you can orient the canoe and head in the direction you want to go. Ocean swells, also used to hold a course, travel from one house on

the horizon to a house directly opposite on the horizon (180 degrees away), passing under the canoe, which is always at the center of the compass.

Star Groups and Hawaiian Names for Stars

The wayfinder must memorize the position of as many stars as possible on the celestial sphere. On cloudy nights, when only parts of the sky are visible, he must be able to recognize isolated stars or star groups and to imagine the rest of the celestial sphere around them. To help remember the pattern of stars in the sky, Nainoa Thompson has organized the sky into three star lines, which appear one after another in the sky.

The three groups have been given the names Ke Ka o Makali'i ("The Canoe-Bailer of Makali'i"), Ka Iwikuamo'o ("The Backbone"), and Manaiakalani ("The Chief's Fishline"). Each group takes up about one fourth of the celestial sphere; a fourth group of stars, as yet unnamed, includes 'Iwa Keli'i (the constellation Cassiopeia) and the Great Square of Pegasus. (Some of the following star names are traditional; others are new; the Polynesian Voyaging Society is in the process of naming in Hawaiian all the major stars, constellations, and quadrants of the celestial sphere.)

One way to remember the sequence of the four quadrants of the sky is to use the mnemonic patterns:

A bowl (the bailer, a half circle of stars); followed by a line (Iwikuamo'o is sometimes called the "North-South Star Line"); followed by a triangle (Manaiakalani contains the three bright stars of the Navigator's Triangle); followed by a square (the fourth quarter of the sky includes the Great Square of Pegasus);

Or a bailer (Ke Ka); followed by a backbone (Iwikuamo'o); followed by a fishhook (Manaiakalani is the name of Maui's fishhook); followed by a seabird ('Iwa)

[KE KA O MAKALI'I \("The Canoe-Bailer of Makali'i"\)](#). Click here for a chart of [the declinations and houses of the stars in and around Ke Ka o Makali'i](#).

Ke Ka o Makali'i is formed by five stars curving across the sky from 'akau (north) to hema (south) in the shape of a bailer, with the bottom toward hikina (east) and the rim toward komohana (west). During Ho'oilō (the winter season from November to April), these stars are visible for most of the night in the Hawaiian sky; during Kau (the summer season from May to October), these stars are in the sky overhead mostly during the daylight hours. The five stars of Ke Ka o Makali'i are the following:

Hoku-lei ("Star-Wreath"ÑMakemson): This sun-yellow star is at the 'akau point of Ke Ka o Makali'i. According to Makemson, Hoku-lei is also the name for a circle of five stars forming a star-lei, the star Hoku-lei being the brightest star in the lei. The haole name for Hoku-lei is Capella (Alpha Aurigae); the name of the constellation formed by the circle of five stars is Auriga ("Charioteer"). According to Johnson and Mahelona, Hoku-lei is an "unidentified star. Lit., 'star-suspended over land'" (5).

Na Mahoe ("The Twins") is a pair of stars. The first of the pair to appear in the Hawaiian sky, a whitish green star, is called Nana-mua ("Look forward"ÐPukui-Elbert); the sun yellow star that follows is called Nana-hope ("Look behind"ÐPukui-Elbert). Johnson-Mahelona and Makemson give the name as "Nana," equivalent to "Ana," or star, so "Nana-mua" means "First star" and "Nana-hope" means "Last star." The pair of stars is also called Nana-mua-ma ("Nana-mua and associate"). Other Hawaiian names: Mahau ("Twins"ÑM), [Ka-Mahana ("Twins"), Na Hoku-Mahana, and Na-lalani-a-Pili-lua ("The lines of the clinging ones"ÑJ & M). The haole name for this pair is Gemini ("The Twins"); Nana-mua is called Castor (Alpha Geminorum) and Nana-hope is called Pollux (Beta Geminorum).

Puana ("Blossom"; a new Hawaiian name based on a Maori name): This light yellow star has no recorded Hawaiian name; in Maori it is called Puanga-hori ("False Puanga") to distinguish it from its pair Puanga or Puanga-rua ("Blossom-

cluster"), or Rigel. The haole name for Puana is Procyon (Alpha Canis Minoris).

'A'a ("Burning brightly"): This blue-white star, the brightest in the sky, is at the hema point of Ke Ka o Makali'i. Johnson and Mahelona suggest 'A'a is also a name for the seabird known as the booby (52), which is used to locate islands; these birds leave their nesting island in the morning to hunt for fish at sea, and return to the island in the evening (range: 30-50 milesÑLewis 171). Other names for this star: Hiki-kau-[e]-lia; Hiki-kau-e-lono (cf. A-iki-kau-e-lono, "The-small-booby-bird-of-Lono"ÑJ & M); Hiki-kau-lono-meha ("Star of solitary Lono"; also Lono or Lono-meha); [Hiki] kaulana-o-meha; Kau-ano-meha ("Standing alone and sacred"ÑM); Hoku-kau'opae ("Star for placing shrimp"ÑJ & M; cf. Kau-opae: "name for Sirius as patron of shrimp fishing"ÑM); [Hoku-ho'okele-wa'a] ("Canoe-guiding star"ÑJ & M); Kaulu-lena, Kaulua-lena ("Yellow star"), or Lena; Kaulua[-i-ha'i-mohai] or [-a-ha'i-mohai] ("Flower of the heavens"ÑM). Makemson says Kaulua means "Bright star"; Kaulua is also the name of a month: February on Hawai'i, June on Moloka'i, and December on O'ahu. The haole name for this star is Sirius (Alpha Canis Majoris).

Stars in and around Ke Ka o Makali'i

Makali'i ("Little eyes" or "Little stars"): This cluster of seven little stars rises ahead of the stars of Ke Ka o Makali'i. According to Makemson, "Maka-li'i" may be interpreted as "High-born stars" ("Maka-ali'i"); Beckwith (367) suggests "Eyes of the chief," Makali'i being the ho'okele (navigator-steersman) for the famous voyager Hawaii-loa. Makali'i was the "guiding star [cluster] for the first month of the year (November-December); also marked the beginning of the year when it rose at sunset. A thousand years ago, the rising of this group of stars in the east would have occurred a month earlier (October-November)." Makali'i was the name of a month (December on Hawai'i, April on Moloka'i, October on O'ahu-Malo 33). Other names for Makali'i: Hu[i]hui ("Group"); Kupuku ("Cluster"). Beckwith says that Makali'i was actually Hoku'ula (Aldebaran), and the cluster of seven stars called Makali'i had the following names: Na-Huihui-o-Makali'i ("The Cluster of Makali'i"), Huihui-koko-a-Makali'i-kau-i-luna ("Makali'i's rainbow colored nets hung above"), Na Wahine-o-Makali'i ("The wife of Makali'i"), Na-ka-

o-Makali'i ("The bailers of Makali'i"), Na-koko-a-Makali'i ("The nets of Makali'i"). According to Makemson, Makali'i is the bow of the Maori canoe Tainui, with the Cross as the anchor, "the Belt of Orion as stern, the Sword as cable, and the Hyades [the face of Taurus] as sail [Te Ra-o-Tainui]" (249). The cluster of seven stars is called the Pleiades in the west.

Hoku'ula ("Red star") or Kapu-ahi ("Sacred fire"): This giant red star appears after Makali'i and Hoku-lei in the Hawaiian sky. Other Hawaiian names include 'Au-kele-nui-a-iku (a legendary hero, "the seeker of the water-of-life, grandson of the mo'o Mo'oinanea, who gave him three magic objects with which to achieve his goals on a long sea journey of forty days"-Johnson and Mahelona, ix; see Fornander, Vol. 4, 32-111, for a version of the legend of 'Au-kele-nui-a-iku); Kao-ma'aiku; Kao. The haole name for this star is Aldebaran (Alpha Tauri).

Ka Hei-hei o na Keiki ("The Cat's Cradle of the Children"; a new Hawaiian name): This constellation with two bright star pairs separated by a row of three stars appears in front of Ke Ka o Makali'i. The name was given because the star group resembles a pattern created in the traditional Hawaiian string game called Hei or Hei-hei. In the West, the two pairs are seen as the points of the shoulders and knees of Orion; the row of three stars is seen as Orion's belt.

Kao-Makali'i, Na Kao ("The Darts of Makali'i"): The three stars in the middle of Ka Hei-hei o na Keiki. In Tonga, the three stars are seen as three canoe paddlers (Kyselka 48). In Kiribati (Gilbert Islands) the three are seen as three fishermen. The haole names for the three stars are Mintaka (Delta Orionis), Alnilam (Epsilon Orionis), and Alnitak (Zeta Orionis).

Kaulua-koko ("Brilliant red star"-Makemson; "koko" means "blood; rainbow-hued"-Pukui Elbert): This red star is the northeast corner of Ka Hei-hei o na Keiki. Other Hawaiian names for this star: Ka'elo (the name of a month: January on Hawai'i, May on Moloka'i, November on O'ahu, and June on Kaua'i-Malo); 'Aua; Hoku-'ula ("Red star"); Koko; Melemele (Name of an ancestral homeland in the north?-J & M). The haole name for this star is Betelgeuse (Alpha Orionis).

Pu'uhonua (westernmost point, the City of Refuge at Honaunau on the Big Island): This star is the southwest corner of Ka Hei-hei o na Keiki. The name is a pun on the Arabic name for the star, "Saiph" ("safe"). The Greek name is Kappa Orionis.

Puana-kau ("Suspended Blossom"-Makemson): This blue-white star, "suspended" above Ke Ka o Makali'i, is the southeast corner of Ka Hei-hei o na Keiki. The haole name for this star is Rigel (Beta Orionis).

Ke ali'i o kona i ka lewa ("The chief of the southern heavens"-Johnson and Mahelona): This bright blue-white star, the second brightest in the sky, appears south of 'A'a. The house of Nalani on the Star Compass was named for it. Its haole name is Canopus (Alpha Carinae).

[KA IWIKUAMO'O \("The Backbone"\)](#) Click here for a chart of [the declinations and houses of the stars in and around Ka Iwikuamo'o.](#)

This star line runs from Hoku-pa'a at the north celestial pole to Hanai-a-kamalama near the south celestial pole. The stars may be seen as vertebrae along a backbone; Iwikuamo'o (lit. "Bone back-lizard") is also a metaphor for a genealogical line, with each vertebra representing a generation. This star line follows Ke Ka o Makali'i into the sky.

Hoku-pa'a ("Fixed star"): This circumpolar star, which does not rise or set in the Hawaiian sky, appears "fixed" at the north celestial pole with other stars circling around it. Actually it is inscribing a circle 1.8 degrees wide around the pole, and because of precession, the wobbling of earth on its axis, Hoku-pa'a is not actually "fixed" permanently. A circle of precession is completed in 26,000 years, and in 13,000 years the north pole will be pointing to the opposite side of the circle of precession, between Hawaiki (Deneb) and Rapanui (Vega) and Hoku-pa'a will appear to be circling the north celestial pole (Kyselka and Lanterman 24-8). Still, in our era, the names for this star suggest its stationary appearance: Noho-loa ("Eternal"), Kumau ("Standing Perpendicularly"), Kio-pa'a/Kio-pa ("Fixed projection"), Kia-pa'akai (Biblical: "Pillar of salt"), Maka-holo-wa'a ("Sailing-canoe eye"-J & M, or "Star of the sailing canoe"-M). The haole name for this star

is Polaris (Alpha Ursae Minoris).

Holopuni ("To circle"; "To sail or travel around"; a new Hawaiian name for this star); also, Hoku-Mau (a new Hawaiian name, in honor of Mau Piailug, the Satawalese navigator who taught non-instrument navigation to Nainoa Thompson; in Hawaiian, "mau" means "constant," "perpetual," "always"). This star appears to circle perpetually around Hoku-pa'a. The haole name for this star is Kochab (Beta Ursae Minoris).

Na Hiku ("The Seven"): This constellation of seven stars arcs around Hoku-pa'ia farther out than Holopuni. "Donaghho gives the full name as Na Hiku-ka-Huihui-a-Makalii, the Cluster-of-the-Seven-of-Makalii. The stars of Na Hiku are individually designated by numbers: Hiku-kahi [Dubhe], Hiku-['a]lua [Merak], Hiku-kolu [Phad], Hiku-[a]ha [Megrez], Hiku-lima [Alioth], Hiku-ono [Mizar], and Hiku-pau, 'Finished' [Alkaid] (Beckwith, *The Kumulipo: A Hawaiian Creation Chant* 208). Hiku-kahi and Hiku-['a]lua point toward Hoku-pa'ia. The haole name for this constellation of seven stars is the Big Dipper.

Hoku-le'a ("Clear Star"): This orange red star, the brightest in the northern hemisphere, appears south of Na Hiku. "A celestial beacon marking the northern destination in the long voyages from the Marquesas and Tahiti to Hawai'i as the zenith star" (Johnson and Mahelona 5). Makemson translates Hoku-le'a as "Star of gladness." The haole name for this star is Arcturus (Alpha Bootis).

Hiki-analia ("Hiki" could mean star; "analia" means ?): This blue-white, medium bright star appears at about the same time as, but to the south of Hoku-le'a. Hiki-analia was "Used as a guide to mariner and fisherman; computed as Spica [Alpha Virginis]" (Johnson and Mahelona 3). Hiki-'au-moana is the Kaua'i name for Hiki-analia (Johnson and Mahelona).

Me'e ("Voice of Joy"-Makemson): Four stars which rise before and to the south of Hikianalia. Me'e is the name of this constellation in the Marquesas, according to Johnson and Mahelona. No recorded Hawaiian name. "Mee is the Marquesan form of the widespread Polynesian star name Mere, Meremere, or Melemele, signifying

'Voice of joy'" -Makemson 235). The Hawaiian form of Me'e, "Mele," means "song" or "chant" or "to sing" or "to chant." "Me'e" in Hawaiian means "hero or heroine" or "heroic," "admired," or "prominent." Johnson and Mahelona identify Melemele or Mere as a name for Orion's belt and a homeland in the north (17). Serepwen and Sarapori are Micronesian names for this constellation. In Pukapuka, it is called Te Manu ("The Bird"-M). The haole name for this constellation is Corvus ("Crow").

Hanai-a-ka-malama ("Cared for by the moon"-Johnson and Mahelona): This group of four stars appears near the southern horizon; it forms a cross with the top and bottom stars pointing toward the south celestial pole. Other Hawaiian names: Newa ("War club"-Pukui-Elbert), Newe, or Newenewe (Guide star to Tahiti-J & M); Ka-pe'a ("The Cross" or "Bat"); Makeaupe'a or Mekeaupe'a (possibly names for the Cross-J & M); Pu-koloa ("Wild duck overhead," possibly the Cross because of a similarity to Tongan and Samoan "Toloa," for the Cross-Makemson); Hoku-kea [-o-ka-mole honua] ("Star-cross-of-the-barren-lands"-M). The haole name for this constellation is the Southern Cross or Crux.

Kaulia ("Suspended" or "Hanging"): This cool red giant is at the top of the cross of Hanai-a-ka-malama. Kaulia has been described traditionally as a prominent star in the Southern Cross; "called the chief of the month of Ikiiki [May] because it appears in that month" (Johnson and Mahelona). The haole name for this star is Gacrux (Gamma Crucis).

(Ka) Mole Honua ("The barren lands"-Makemson; a new Hawaiian name for this star based on a possible name for Hanai-a-ka-malama, Hoku-kea [-o-ka-mole honua]-"Star-cross-of-the-barren-lands"-Makemson): This bright blue star is at the bottom of the cross of Hanai-a-ka-malama. Pukui-Elbert define mole as "tap root," "bottom," "ancestral root," "foundation," "source"; "smooth" or "bald" [Makemson's "barren"]; "to linger," "to loiter." "Honua" means "land" or "earth." Mole Honua may be seen as the ancestral root or foundation of Ka Iwikuamo'o, which metaphorically refers to a genealogical line. The haole name for this star is Acrux (Alpha Crucis).

Na Kuhikuhi ("The Pointers"; translation of the haole name for a pair of

stars which points to Hanai-a-ka-malama): These two stars follow Hanai-a-ka-malama into the southern sky and point to it. The first of the pair of stars is called Ka-maile-mua ("The first maile"-Johnson and Mahelona); the haole name of this star is Hadar (Beta Centauri). The second star of the pair is called Ka-maile-hope ("The last maile"-Johnson and Mahelona); the haole name is Rigel Kentaurus (Alpha Centauri). In Kapingamarangi, Ka-maile-mua and Ka-maile-hope are also a pair: Ti-humu-uri and Ti-humu-te (Johnson and Mahelona 129).

[MANAIAKALANI \("The Chief's Fishline"\)](#) Click here for a chart of [the declinations and houses of the stars in and around Manaiakalani.](#)

Manaiakalani ("The Chief's Fishline"-Johnson and Mahelona; "Come-From-Heaven"-Beckwith and Makemson) is the name of the demi-god Maui's fishhook, which he used to hook land at the bottom of the ocean, in some areas of Polynesia to drag up new islands, but in Hawai'i to pull the islands closer together. Manaiakalani is also the name of the fishhook of the Hawaiian fishing god Ku'ulakai and his son 'Ai'ai. This star line ("The Chief's Fishline") goes from 'Iwa Keli'i in the north to Ka Makau Nui o Maui in the south, and is dominated by the northern triangle (Huinakolu) formed by three bright stars seen as representing the Polynesian triangle, with Hawaiki, Rapa-nui, and Aotearoa at the corners. The Manaiakalani star line follows the Iwikuamo'o star line into the sky. In the Hawaiian sky of Kau (summer season, May to October), Manaiakalani is visible for most of the night, just as Ke Ka o Makali'i is visible for most of the night in the sky of Ho'oilo (winter season, November to April). Ka Makau Nui o Maui in Manaiakalani is on the opposite side of the sky (180 degrees away) from Ka Hei-hei o na Keiki in Ke Ka o Makali'i.

Hawaiki (Hawai'i; a new name): This brilliant white super giant is the northernmost star in Huinakolu. No recorded Hawaiian name; in the Society Islands, it is called Pira'e-tea ("White sea swallow") or Taíurua-i-te-haíaparaía-manu ("Festivity-of-the-ascending-bird"-Johnson's pronunciations; Makemson's definitions). The Pira'e was the pet bird of Ra'i-tupua, Sky-builder, who in

Tahitian mythology, puts the sky in order after Tane raises it on posts: "Tane measured the spaces between the skies with his sky measure. And while Ra'i-tupua reached up from below and set the Sun and stars and other heavenly bodies in the blue heights, his artisan Ma-tohi, Clearing adze, adjusted them nicely from above. Thus the sky Atea became clear and unobstructed for the gods to fly through" (Makemson 70). The haole name for this star is Deneb (Alpha Cygni).

Rapa-nui (a Polynesian name for Easter Island; a new name): This bright blue star is the first in Huinakolu to appear. Keoe, Keoea, Keho'oea are traditional Hawaiian names: "Keoe is a Hawaiian name which Alexander believes was applied to Vega (Alpha Lyrae); but Kupahu describes it as a group of four stars forming a diamond. Hence it probably stood for the entire constellation of Lyra" (Makemson 220).

Aotearoa (the Maori name for New Zealand; a new name): Traditionally called Humu; this star and the two around it were called Humu-ma and were named for a famous ho'okele and his two sons. The legend told by Kupahu (Johnson and Mahelona 167-8) suggests Humu was a guide star to Kaua'i when a canoe sailed from O'ahu. Humu's two sons sail with the first canoes; the older son who knows star lore gives his advice on which direction to sail in, which angers the steersman. The steersman throws Humu's two sons overboard; they swim behind the stars known as Humu-ma and are rescued by their father, who sails in the last canoe with the King; Humu and his two sons reach Kaua'i, while the rest of the canoes are lost at sea. The haole name for this star is Altair (Alpha Aquilae).

Other Constellations and Stars of Manaiakalani

Nai'a ("Dolphin" or "Porpoise"): This constellation rises after Aoteraroa. The name is a translation of the haole name Delphinus, or Dolphin.

Ka Makau Nui o Maui ("The Big Fishhook of Maui"): This constellation is also called Manaiakalani. The haole name for this constellation shaped like a fishhook is Scorpius.

Lehua-kona ("Southern Leahua blossom"): This red star is on the shank of Ka Makau Nui o Maui. Leahua indicates the color red; or Leahua could be the Hawaiian form of Rehua, the Maori name for Leahua-kona: "Rehua is a star, a bird with two wings; one wing is broken. Under the unbroken wing is Te Waa-o-Tamarereti [the Canoe of Tamarereti is the Tail of Scorpius in this instance]. When Rehua mates with his wife Pekehawani [a star close to Lehuakona] the ocean is windless and motionless.' The generally accepted version of the Rehua myth, according to Best, is that Rehua had two wives, the stars on either side of [Lehua-kona]. One was Ruhi-te-rangi or Pekehawani, the personification of summer languour [ruhi], the other Whak-aonge-kai, She-who-makes food scarce before the new crops can be harvested. Rehua was the guiding star of the Aotea canoe, the craft in which Turi arrived on the west coast of New Zealand, following Kupe's sailing directions"- Makemson 249-50); Leahua-kona is also called Hoku'ula ("Red star"). The haole name for Leahua-kona is Antares (Alpha Scorpii).

Ka Maka ("The point of the fishhook"; a new name for this star at the point of Ka Makau Nui o Maui; Maka also means "eye" or "favorite"; could be related to the Polynesian name for star "mata"): No recorded Hawaiian name. The Maoris see the hook portion of Ka Makau Nui o Maui as Te Waka-o-Tamarereti, the Canoe-of-Tamarereti (Makemson 267-8). The haole name for this star is Shaula (Lambda Scorpii).

[KA LUPE O KAWELO \("The Kite of Kawelo"\)](#) Click here for a chart of [the declinations and houses of the stars in and around Ka Lupe o Kawelo.](#)

The fourth quarter of the sky contains Ka Lupe o Kawelo ("The Kite of Kawelo"), the Hawaiian name given to the Great Square of Pegasus; this quarter also includes the constellation 'Iwa Keli'i (Cassiopeia), as well as the constellations Aries, the Ram, and Cetus, the Whale, and the bright stars Fomalhaut and Achernar in the south.

'Iwa Keli'i ('Iwa, the Chief; the 'iwa is the frigate or man-of-war bird; a new name): This new name refers to the bird-like figure of the constellation Cassiopeia, which rises and sets north of the Great Square of Pegasus. The 'iwa

(man-of-war bird), like the noio (Hawaiian tern), the manu-o-Ku (fairy tern), and the 'a (the booby), were helpful in locating islands, as they fly out to fish in the morning and return to their islands in the evening. Traditionally, Schedir (Alpha Cassiopeiae) may have been called Polo-ahi-lani ("Shining in heaven"; also Polohilani, the name of one of Hawaii-loa's mariners); Caph (Beta Cassiopeiae) may have been called Polo'ula ("Shining red"; this star may also have been known as Pohina); and Navi (Gamma Cassiopeiae) may have been called Mulehu ("Twilight," cf. Lehu, "ashes"). According to Makemson, Poloahilani was "named for a blind king of Hawaii. Kupahu remarks: 'The character of this star is blindness, and it shows a whiteness when observed in the night. Poloahilani had two attendants to guide him in and out, one to hold him by the right hand, the other by the left. Through the blindness of this king, his misfortune is applied in the heavens and placed with those stars of the three names mentioned above'" (237). In Micronesia, 'Iwa is seen as a fish or porpoise (Johnson and Mahelona).

A wayfinder uses many more stars than those listed in the four star groups above; while many more stars were probably named and known in ancient Hawai'i, their names have been lost. Some of these other wayfinding stars are given on the graphics of each star group; eventually, the Polynesian Voyaging Society hopes to give all these stars Hawaiian names. (See the bibliography for a list of sources for Hawaiian star names.)

1976: Tahiti	1980: Tahiti	1985-87: Aotearoa (New Zealand)	1992: Rarotonga	1995: Marquesas	1995: West Coast, British Columbia, & Alaska	1999-2000: Rapanui
Voyages	Canoe- Building	Wayfinding	Life on a Canoe	Polynesian Migrations	Proverbs and Traditions	
Home	Search	Archives	Past Ed Programs and Materials	On-Line Visuals	Bibliographies (Books and Films)	

WAYFINDERS

A PACIFIC ODYSSEY



"Preparing for a voyage on a canoe is like preparing for the voyage into the future."

The Game

About the Film

Polynesian History & Origin

Wayfinding

Sharing Stories

Ask the Experts

Resources

Site Map

Site Credits

Buy the Video



Pacific Islanders
IN COMMUNICATION

Centuries before European explorers ventured beyond their shorelines, the ancestors of today's Polynesians had sailed to every habitable island in the far corners of the Pacific. This ancient Polynesian sea voyaging tradition comes to life again in "Wayfinders: A Pacific Odyssey."

This Web site companion begins where the program ends. Begin your online journey by investigating the film's major themes and subjects in greater depth. Learn more about Pacific Island geography, culture, history, archaeology, linguistics and celestial navigation, and ask questions of the experts who provided background information for the film.

- [Home](#) • [About the Film](#) • [Polynesian History and Origin](#) • [Wayfinding](#) • [Sharing Stories](#) • [Ask the Experts](#) • [Resources](#) • [Site Credits](#) • [Site Map](#) • [Buy the Video](#) •



amazon.com



VIEW CART

WISH LIST

YOUR ACCOUNT

HELP

WELCOME

YOUR STORE

BOOKS

APPAREL & ACCESSORIES

ELECTRONICS

TOYS & GAMES

MUSIC

CELL PHONES & SERVICE



SEE MORE STORES

Search

Browse Subjects

Bestsellers

Magazines

Corporate Accounts

e-books & docs

New & Used Textbooks

Used Books

Search:

Browse:

You clicked on this item...



We, the Navigators

by David Lewis, Derek, Sir Oulton

Average Customer Review: ★★★★★

Usually ships in 24 hours



Eligible for FREE Super Saver Shipping on orders over \$25. See details.

Price: \$19.01

You Save: \$8.94 (32%)

14 used & new from \$15.88

The Northern Mariner

"Intensely thorough... An exhaustive examination of the pre-European navigational system which should fill any scholar's need... Succeeds admirably."

Or buy used: \$15.88

You may also be interested in these items...

Customers also shopped for

Show items from:

All Products

Books (20)

DVD (2)



The Last Navigator

by Stephen D. Thomas

More like this



Canoes of Oceania (Special Publications - Bernice P. Bishop Museum; 27-29)

by J. Haddon A. C.&Hornell

More like this



On the Road of the Winds

by Patrick Vinton Kirch

More like this



Voyage of Rediscovery

by Ben R. Finney, Ben Finney

More like this

An Ocean in Mind (A Kolowalu Book)

by Will Kyselka



More like this



Reference Map of Oceania

by James A. Bier

More like this

	 <p><u>The Journals (Penguin Classics)</u> by James Cook, et al More like this</p>	<p><u>East Is a Big Bird; Navigation and Logic on Puluwat Atoll.</u> by Thomas, Gladwin More like this</p>	 <p><u>The Complete On-Board Celestial Navigator</u> by George C. Bennett More like this</p>
--	---	---	---









[More results](#) ▶

<p>New at Amazon.com Visit our new Seasonal Tableware Store and save up to 40% on Lenox, Spode, and more.</p>	<p>\$25 Off Tools & Hardware Take \$25 off when you spend \$199 or more on Tools & Hardware products offered by Amazon.com. Here's how (restrictions apply).</p> <p>\$25 Offer</p>	<p>New at Amazon.com</p>  <p>Find more than 600,000 china, crystal, and silver products in the Replacements, Ltd. Store.</p> <p>REPLACEMENTS LTD.</p>
--	--	--

<p>Where's My Stuff?</p> <ul style="list-style-type: none"> Track your recent orders. View or change your orders in Your Account. 	<p>Shipping & Returns</p> <ul style="list-style-type: none"> See our shipping rates & policies. Return an item (here's our Returns Policy). 	<p>Need Help?</p> <ul style="list-style-type: none"> Forgot your password? Click here. Redeem or buy a gift certificate. Visit our Help department.
--	--	---

Search **for**

Your Recent History
[Learn More](#)

<p>Recently Viewed Products</p> <ul style="list-style-type: none">  The Sextant Handbook by Bruce Bauer  Emergency Navigation by David Burch  Taking the Stars by Peter Ifland  Navigation in the Age of Discovery by Duane A. Cline  Carry On, Mr. Bowditch by Jean Lee Latham, John O'Hara Cosgrave <p>▶ Visit the Page You Made</p>	<p>Customers who bought items in your Recent History also bought:</p> <div style="display: flex; justify-content: space-around;"> <div data-bbox="812 1333 1169 1596">  <p> Celestial Navigation for Yachtsmen by Mary Blewitt</p> </div> <div data-bbox="1169 1333 1591 1596">  <p> Latitude Hooks and Azimuth Rings by Dennis Fisher</p> </div> </div>
--	--

Turn your past books purchases into \$\$\$
[Learn more](#) about selling at Amazon.com today!

[Books Search](#) | [Browse Subjects](#) | [Bestsellers](#) | [Magazines](#) | [Corporate Accounts](#)
[e-Books & Docs](#) | [Bargain Books](#) | [Used Books](#)

[Amazon.com Home](#) | [Directory of All Stores](#)

Our International Sites: [Canada](#) | [United Kingdom](#) | [Germany](#) | [Japan](#) | [France](#)

[Contact Us](#) | [Help](#) | [Shopping Cart](#) | [Your Account](#) | [Sell Items](#) | [1-Click Settings](#)

[Investor Relations](#) | [Press Releases](#) | [Join Our Staff](#)

[Conditions of Use](#) | [Privacy Notice](#) © 1996-2004, Amazon.com, Inc. or its affiliates



amazon.com



VIEW CART | WISH LIST | YOUR ACCOUNT | HELP

WELCOME

YOUR STORE

BOOKS

APPAREL & ACCESSORIES

ELECTRONICS

TOYS & GAMES

MUSIC

CELL PHONES & SERVICE

SEE MORE STORES

Search

Browse Subjects

Bestsellers

Magazines

Corporate Accounts

e-books & docs

New & Used Textbooks

Used Books

Search:

Browse:

You clicked on this item...



The Last Navigator

by [Stephen D. Thomas](#)

Average Customer Review: ★★★★★
Usually ships in 24 hours

Price: **\$11.17**
You Save: **\$4.78 (30%)**

31 used & new from **\$3.25**



Eligible for **FREE Super Saver Shipping** on orders over \$25. [See details.](#)

From Library Journal

Thomas, an experienced deep-water sailor, had long been fascinated by Micronesian navigators who, without maps, compasses, or sextants, sailed hundreds of miles between the islands of Oceania. To discover how these men traveled with only natural signs for guidance, he apprenticed himself to one of... [Read more](#)

Or [buy used](#): **\$3.25**

You may also be interested in these items...

[Customers also shopped for](#)

Show items from:

▶ **All Products**

[Books](#) (20)

[DVD](#) (1)

[Music](#) (1)



We, the Navigators

by David Lewis, Derek, Sir Oulton

More like this



On the Road of the Winds

by Patrick Vinton Kirch

More like this



Canoes of Oceania (Special Publications - Bernice P. Bishop Museum; 27-29)

by J. Haddon A. C. & Hornell

More like this



Emergency Navigation

by David Burch

More like this



Reference Map of Oceania

by James A. Bier

More like this



The Ancient Mariners

by Lionel Casson

More like this

	 Hokule'a by Ben R Finney More like this	 The Complete On-Board Celestial Navigator by George C. Bennett More like this	 Arab Seafaring by George F. Hourani More like this
--	---	---	--

















[More results](#) 

<p>New at Amazon.com Visit our new Seasonal Tableware Store and save up to 40% on Lenox, Spode, and more.</p>	<p>\$25 Off Tools & Hardware Take \$25 off when you spend \$199 or more on Tools & Hardware products offered by Amazon.com. Here's how (restrictions apply).</p> <p style="font-size: 2em; color: orange; font-weight: bold;">\$25 Offer</p>	<p>New at Amazon.com</p>  Find more than 600,000 china, crystal, and silver products in the Replacements, Ltd. Store . REPLACEMENTS LTD.
---	--	---

<p>Where's My Stuff?</p> <ul style="list-style-type: none"> Track your recent orders. View or change your orders in Your Account. 	<p>Shipping & Returns</p> <ul style="list-style-type: none"> See our shipping rates & policies. Return an item (here's our Returns Policy). 	<p>Need Help?</p> <ul style="list-style-type: none"> Forgot your password? Click here. Redeem or buy a gift certificate. Visit our Help department.
--	--	---

Search **for**

Your Recent History
[Learn More](#)

<p>Recently Viewed Products</p> <ul style="list-style-type: none">  We, the Navigators by David Lewis, Derek, Sir Oulton  The Sextant Handbook by Bruce Bauer  Emergency Navigation by David Burch  Taking the Stars by Peter Ifland  Navigation in the Age of Discovery by Duane A. Cline 	<p>Customers who bought items in your Recent History also bought:</p> <table border="0" style="width: 100%;"> <tr> <td style="width: 50%; text-align: center;">   Latitude Hooks and Azimuth Rings by Dennis Fisher </td> <td style="width: 50%; text-align: center;">   Celestial Navigation for Yachtsmen by Mary Blewitt </td> </tr> </table>	  Latitude Hooks and Azimuth Rings by Dennis Fisher	  Celestial Navigation for Yachtsmen by Mary Blewitt
  Latitude Hooks and Azimuth Rings by Dennis Fisher	  Celestial Navigation for Yachtsmen by Mary Blewitt		

[Visit the Page You Made](#)

Turn your past books purchases into \$\$\$
[Learn more](#) about selling at Amazon.com today!

[Books Search](#) | [Browse Subjects](#) | [Bestsellers](#) | [Magazines](#) | [Corporate Accounts](#)
[e-Books & Docs](#) | [Bargain Books](#) | [Used Books](#)

[Amazon.com Home](#) | [Directory of All Stores](#)

Our International Sites: [Canada](#) | [United Kingdom](#) | [Germany](#) | [Japan](#) | [France](#)

[Contact Us](#) | [Help](#) | [Shopping Cart](#) | [Your Account](#) | [Sell Items](#) | [1-Click Settings](#)

[Investor Relations](#) | [Press Releases](#) | [Join Our Staff](#)

[Conditions of Use](#) | [Privacy Notice](#) © 1996-2004, Amazon.com, Inc. or its affiliates



amazon.com



VIEW CART | WISH LIST | YOUR ACCOUNT | HELP

WELCOME

YOUR STORE

BOOKS

APPAREL & ACCESSORIES

ELECTRONICS

TOYS & GAMES

MUSIC

CELL PHONES & SERVICE

SEE MORE STORES

Search

Browse Subjects

Bestsellers

Magazines

Corporate Accounts

e-books & docs

New & Used Textbooks

Used Books

Search:

Browse:

You clicked on this item...



Voyage of Rediscovery

by [Ben R. Finney](#), [Ben Finney](#)
Usually ships in 24 hours

Price: **\$21.95**

20 used & new from **\$8.98**



Eligible for **FREE Super Saver Shipping** on orders over \$25. [See details.](#)

Ingram

In the summer of 1985, a mostly Hawaiian crew set out in a reconstructed, ancient double canoe to demonstrate what skeptics had always denied--that their ancestors could have intentionally sailed across the Pacific and explored Polynesia. Voyage of Rediscovery is the vivid, remarkable account of... [Read more](#)

Or [buy used](#): **\$8.98**

You may also be interested in these items...

Show items from:

- ▶ **All Products**
- [Books](#) (4)

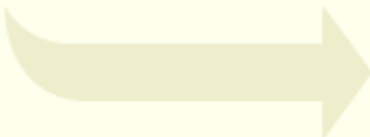

<p>Hokule'a by Ben R Finney More like this</p>	 <p>We, the Navigators by David Lewis, Derek, Sir Oulton More like this</p>	<p>An Ocean in Mind (A Kolowalu Book) by Will Kyselka More like this</p>
<p>Sailing in the Wake of the Ancestors by Ben R. Finney More like this</p>		

New at Amazon.com

Visit our new [Seasonal Tableware Store](#) and save up to 40% on Lenox, Spode, and more.

\$25 Off Tools & Hardware

\$25 Offer

Take \$25 off when you spend \$199 or more on [Tools & Hardware](#) products offered by Amazon.com. [Here's how](#) (restrictions apply).

New at Amazon.com



REPLACEMENTS, LTD.

Find more than 600,000 china, crystal, and silver products in the [Replacements, Ltd. Store](#).

Where's My Stuff?

- Track your [recent orders](#).
- View or change your orders in [Your Account](#).

Shipping & Returns

- See our [shipping rates & policies](#).
- [Return](#) an item (here's our [Returns Policy](#)).

Need Help?

- Forgot your password? [Click here](#).
- [Redeem](#) or [buy](#) a gift certificate.
- [Visit our Help department](#).

Search

for

Your Recent History

[Learn More](#)

Recently Viewed Products

- [The Last Navigator](#) by Stephen D. Thomas
- [We, the Navigators](#) by David Lewis, Derek, Sir Oulton
- [The Sextant Handbook](#) by Bruce Bauer
- [Emergency Navigation](#) by David Burch
- [Taking the Stars](#) by Peter Ifland

Customers who bought items in your Recent History also bought:

- [The Complete On-Board Celestial Navigator](#) by George C. Bennett
- [Celestial Navigation for Yachtsmen](#) by Mary Blewitt

▶ [Visit the Page You Made](#)

Turn your past books purchases into \$\$\$
[Learn more about selling at Amazon.com today!](#)

[Top of Page](#)

[Books Search](#) | [Browse Subjects](#) | [Bestsellers](#) | [Magazines](#) | [Corporate Accounts](#)
[e-Books & Docs](#) | [Bargain Books](#) | [Used Books](#)

[Amazon.com Home](#) | [Directory of All Stores](#)

Our International Sites: [Canada](#) | [United Kingdom](#) | [Germany](#) | [Japan](#) | [France](#)

[Contact Us](#) | [Help](#) | [Shopping Cart](#) | [Your Account](#) | [Sell Items](#) | [1-Click Settings](#)

[Investor Relations](#) | [Press Releases](#) | [Join Our Staff](#)

[Conditions of Use](#) | [Privacy Notice](#) © 1996-2004, Amazon.com, Inc. or its affiliates



PicAPageDiscounts



[HOME PAGE](#)

- [Affiliates](#)
- [Apparel](#)
- [Art/Artist](#)
- [Auctions](#)
- [Automotive](#)
- [Boating](#)
- [Books/Media](#)
- [Business](#)
- [Catalogs](#)
- [Computers](#)
- [Cosmetics](#)
- [Credit Cards](#)
- [Education](#)
- [Electronics](#)
- [Employment](#)
- [Entertainment](#)
- [Family](#)
- [Finance](#)
- [Flowers](#)
- [Food/Drink](#)
- [Footwear](#)
- [Gifts](#)
- [Golf](#)
- [Health/Beauty](#)
- [Hobby/Photo](#)
- [Home Improvement](#)
- [Ink Cartridges](#)
- [Insurance](#)
- [Internet](#)
- [Jewelry](#)
- [Magazines](#)
- [Music](#)
- [Personals](#)
- [Phones](#)
- [Sports](#)
- [Toys/Games](#)
- [Travel](#)
- [UK/EURO](#)

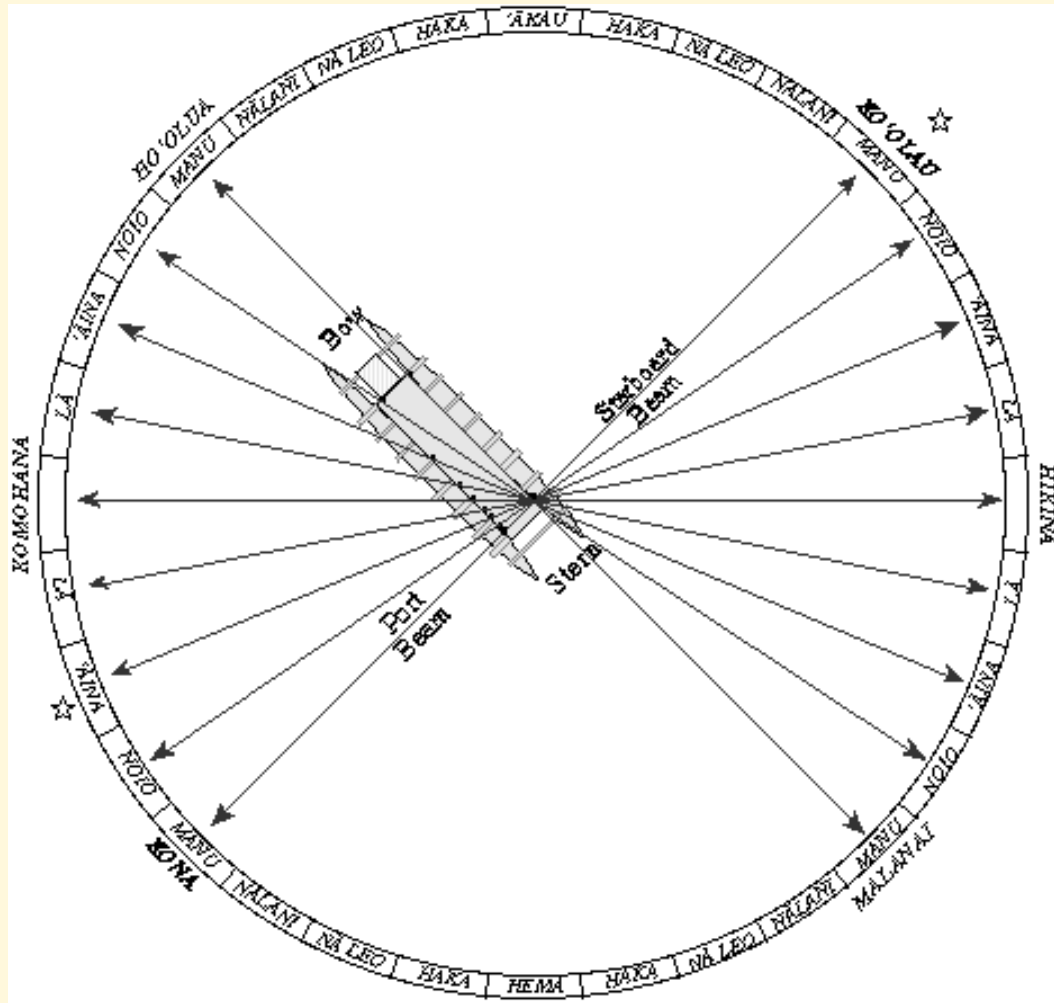

Ke Ali'i o Kona i ka Lewa (Larry W. Jones 08/07/2003) (song#1859)

Ke Ali'i o Kona i ka Lewa
 Guiding star in heaven so bright
 Shining softly your silvery light
 You have guided canoes from islands afar
 Hokuahiahi, wayfinding star
 Star of the heavens, wayfinding star

Wayfinding star, star of the heavens
 From islands afar you guided canoes

Hokuahiahi, wayfinding star
All polynesia wants to thank you

Ke Ali'i o Kona i ka Lewa
Like eyes in the night, you seem to say
Come with me to isles far away
Polynesian sailors followed that star
Hokuahiahi, wayfinding star
Star of the heavens, wayfinding star

Wayfinding star, star of the heavens
From islands afar you guided canoes
Hokuahiahi, wayfinding star
All polynesia wants to thank you

Ke Ali'i o Kona i ka Lewa
Shine on, oh guiding star so divine
Shine on with your silvery light
Guide sailors safely to these isles of mine
Hokuahiahi, wayfinding star
Star of the heavens, wayfinding star

Wayfinding star, star of the heavens
From islands afar you guided canoes
Hokuahiahi, wayfinding star
All polynesia wants to thank you



[Return to Island Song Lyrics](#)



Search:

Browse:

You clicked on this item...

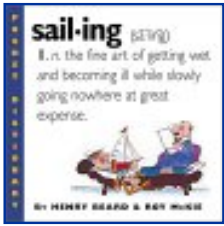

Sailing

by Henry Beard, Roy McKie

Average Customer Review: ★★★★★
Usually ships in 24 hours

Price: \$7.95

45 used & new from \$0.32



Eligible for **FREE Super Saver Shipping** on orders over \$25. [See details.](#)

Or [buy used](#): \$0.32

From the Inside Flap

sailing the fine art of getting wet and becoming ill while slowly going nowhere at great expense.

You may also be interested in these items...

Show items from:

▶ All Products

Books (4)

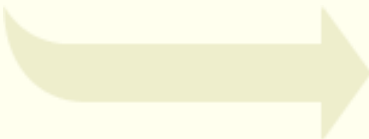

Cooking

by Henry Beard, Roy McKie

More like this



Poetry for Cats

by Henry Beard, Gary Zamchick

More like this



Sailing for Dummies

by J. J. Isler, Peter Isler

More like this



Computing

by Henry Beard, Roy McKie

More like this

New at Amazon.com

Visit our new [Seasonal Tableware Store](#) and save up to 40% on Lenox, Spode, and more.

\$25 Off Tools & Hardware

\$25 Offer

Take \$25 off when you spend \$199 or more on [Tools & Hardware](#) products offered by Amazon.com. [Here's how](#) (restrictions apply).

New at Amazon.com



Find more than 600,000 china, crystal, and silver products in the [Replacements, Ltd. Store](#).

REPLACEMENTS, LTD.

Where's My Stuff?

- Track your [recent orders](#).
- View or change your orders in [Your Account](#).

Shipping & Returns

- See our [shipping rates & policies](#).
- [Return](#) an item (here's our [Returns Policy](#)).

Need Help?

- Forgot your password? [Click here](#).
- [Redeem](#) or [buy](#) a gift certificate.
- [Visit our Help department](#).

Search

for

Your Recent History

[Learn More](#)

Recently Viewed Products

- [Voyage of Rediscovery](#) by Ben R. Finney, Ben Finney
- [The Last Navigator](#) by Stephen D. Thomas
- [We, the Navigators](#) by David Lewis, Derek, Sir Oulton
- [The Sextant Handbook](#) by Bruce Bauer
- [Emergency Navigation](#) by David Burch

Customers who bought items in your Recent History also bought:

- [The Complete On-Board Celestial Navigator](#) by George C. Bennett
- [Celestial Navigation for Yachtsmen](#) by Mary Blewitt

[Visit the Page You Made](#)

Turn your past books purchases into \$\$\$
[Learn more](#) about selling at Amazon.com today!

[Top of Page](#)

[Books Search](#) | [Browse Subjects](#) | [Bestsellers](#) | [Magazines](#) | [Corporate Accounts](#)
[e-Books & Docs](#) | [Bargain Books](#) | [Used Books](#)

[Amazon.com Home](#) | [Directory of All Stores](#)

Our International Sites: [Canada](#) | [United Kingdom](#) | [Germany](#) | [Japan](#) | [France](#)

[Contact Us](#) | [Help](#) | [Shopping Cart](#) | [Your Account](#) | [Sell Items](#) | [1-Click Settings](#)

[Investor Relations](#) | [Press Releases](#) | [Join Our Staff](#)



WELCOME

YOUR STORE

BOOKS

APPAREL & ACCESSORIES

ELECTRONICS

TOYS & GAMES

MUSIC

CELL PHONES & SERVICE

SEE MORE STORES

Search

Browse Subjects

Bestsellers

Magazines

Corporate Accounts

e-books & docs

New & Used Textbooks

Used Books

Search:

Browse:

You clicked on this item...



The Cruise of the Snark

by [Jack London](#)

Average Customer Review: ★★★★★
Usually ships in 24 hours



Eligible for **FREE Super Saver Shipping** on orders over \$25. [See details.](#)

Price: \$10.47
You Save: \$4.48 (30%)

19 used & new from **\$3.28**

About the Author

Jack London (1876–1916) published an enormous number of stories and novels, including *The Call of the Wild*, *White Fang*, and *Martin Eden*.

R. D. Madison is a professor of English at the U.S. Naval Academy in Annapolis, Maryland. He has edited several volumes of military and naval history,... [Read more](#)

Or [buy used](#): **\$3.28**

You may also be interested in these items...

[Customers also shopped for](#)

Show items from:

▶ **All Products**

[Books](#) (20)

[DVD](#) (2)

[Music](#) (1)



South Sea Tales (Modern Library Classics)

by Jack London, et al

[More like this](#)

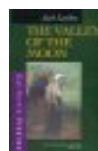

The Valley of the Moon (California Fiction)

by Jack London

[More like this](#)



Two Years Before the Mast

by Richard Henry, Jr. Dana, Gary Kinder

[More like this](#)



The Sea Wolf

by Jack London

[More like this](#)



In the South Seas (Penguin Classics)

by Robert Louis Stevenson, Neil Rennie

[More like this](#)



The Mirror of the Sea

by Joseph Conrad

[More like this](#)



Around the World Single-Handed

by Harry Pidgeon

[More like this](#)



Following the Equator

by Mark Twain

[More like this](#)



The Saga of Cimba

by Richard Maury

[More like this](#)

[More results](#)

New at Amazon.com

Visit our new [Seasonal Tableware Store](#) and save up to 40% on Lenox, Spode, and more.

\$25 Off Tools & Hardware

\$25 Offer

Take \$25 off when you spend \$199 or more on [Tools & Hardware](#) products offered by Amazon.com. [Here's how](#) (restrictions apply).

New at Amazon.com



REPLACEMENTS LTD.

Find more than 600,000 china, crystal, and silver products in the [Replacements, Ltd. Store](#).

Where's My Stuff?

- Track your [recent orders](#).
- View or change your orders in [Your Account](#).

Shipping & Returns

- See our [shipping rates & policies](#).
- [Return](#) an item (here's our [Returns Policy](#)).

Need Help?

- Forgot your password? [Click here](#).
- [Redeem](#) or [buy](#) a gift certificate.
- [Visit our Help department](#).

Search

for

Your Recent History

[Learn More](#)

Recently Viewed Products

- [Sailing](#) by Henry Beard, Roy McKie
- [Voyage of Rediscovery](#) by Ben R. Finney, Ben Finney
- [The Last Navigator](#) by Stephen D. Thomas
- [We, the Navigators](#) by David Lewis, Derek, Sir Oulton
- [The Sextant Handbook](#) by Bruce Bauer

Customers who bought items in your Recent History also bought:



- [The Complete On-Board Celestial Navigator](#) by George C. Bennett



- [Canoes of Oceania \(Special Publications - Bernice P. Bishop Museum; 27-29\)](#) by J. Haddon A. C.&Hornell

[Visit the Page You Made](#)

Turn your past books purchases into \$\$\$
[Learn more](#) about selling at Amazon.com today!

[Top of Page](#)

[Books Search](#) | [Browse Subjects](#) | [Bestsellers](#) | [Magazines](#) | [Corporate Accounts](#)
[e-Books & Docs](#) | [Bargain Books](#) | [Used Books](#)

[Amazon.com Home](#) | [Directory of All Stores](#)

Our International Sites: [Canada](#) | [United Kingdom](#) | [Germany](#) | [Japan](#) | [France](#)

[Contact Us](#) | [Help](#) | [Shopping Cart](#) | [Your Account](#) | [Sell Items](#) | [1-Click Settings](#)

[Investor Relations](#) | [Press Releases](#) | [Join Our Staff](#)

[Conditions of Use](#) | [Privacy Notice](#) © 1996-2004, Amazon.com, Inc. or its affiliates



amazon.com



VIEW CART

WISH LIST

YOUR ACCOUNT

HELP

WELCOME

YOUR STORE

BOOKS

APPAREL & ACCESSORIES

ELECTRONICS

TOYS & GAMES

MUSIC

CELL PHONES & SERVICE

SEE MORE STORES

Search

Browse Subjects

Bestsellers

Magazines

Corporate Accounts

e-books & docs

New & Used Textbooks

Used Books

Search:

Browse:

You clicked on this item...



The Mirror of the Sea

by [Joseph Conrad](#)

Usually ships in 24 hours



Eligible for **FREE Super Saver Shipping** on orders over \$25. [See details.](#)

Price: \$8.76

You Save: \$2.19 (20%)

10 used & new from \$5.50

Or [buy used](#): \$6.50

You may also be interested in these items...

[Customers also shopped for](#)

Show items from:

▶ **All Products**

[Books](#) (6)



Chance

by Joseph Conrad

[More like this](#)



The Cruise of the Snark

by Jack London

[More like this](#)



Under Western Eyes (Penguin Twentieth-Century Classics X)

by Joseph Conrad, Paul Kirschner

[More like this](#)



Victory

by Joseph Conrad

[More like this](#)



Nostromo a Tale of the Seaboard (Penguin Great Books of the 20th Century)

by Joseph Conrad

[More like this](#)



Lord Jim (Penguin Classics)

by Joseph Conrad, et al

[More like this](#)

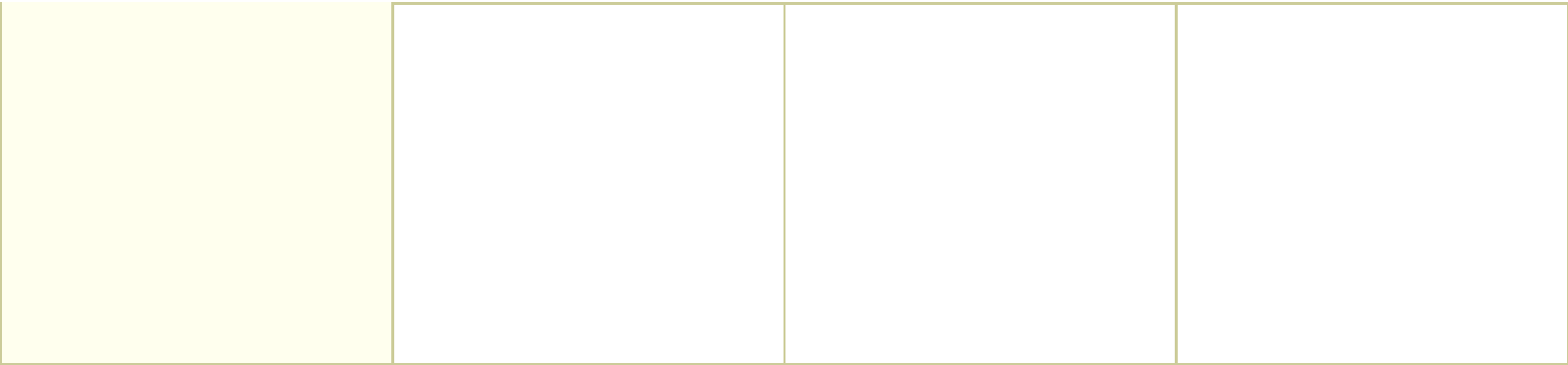

New at Amazon.com

Visit our new [Seasonal Tableware Store](#) and save up to 40% on Lenox, Spode, and more.

\$25 Off Tools & Hardware

\$25 Offer

Take \$25 off when you spend \$199 or more on [Tools & Hardware](#) products offered by Amazon.com. [Here's how](#) (restrictions apply).

New at Amazon.com



REPLACEMENTS, LTD.

Find more than 600,000 china, crystal, and silver products in the [Replacements, Ltd. Store](#).

Where's My Stuff?

- Track your [recent orders](#).
- View or change your orders in [Your Account](#).

Shipping & Returns

- See our [shipping rates & policies](#).
- [Return](#) an item (here's our [Returns Policy](#)).

Need Help?

- Forgot your password? [Click here](#).
- [Redeem](#) or [buy](#) a gift certificate.
- [Visit our Help department](#).

Search

for

Your Recent History

[Learn More](#)

Recently Viewed Products

- [The Cruise of the Snark](#) by Jack London
- [Sailing](#) by Henry Beard, Roy McKie
- [Voyage of Rediscovery](#) by Ben R. Finney, Ben Finney
- [The Last Navigator](#) by Stephen D. Thomas
- [We, the Navigators](#) by David Lewis, Derek, Sir Oulton

Customers who bought items in your Recent History also bought:



[Reference Map of Oceania](#)
by James A. Bier



[Canoes of Oceania \(Special Publications - Bernice P. Bishop Museum; 27-29\)](#)
by J. Haddon A. C. & Hornell

▶ [Visit the Page You Made](#)

Turn your past books purchases into \$\$\$
[Learn more](#) about selling at Amazon.com today!

[Top of Page](#)

[Books Search](#) | [Browse Subjects](#) | [Bestsellers](#) | [Magazines](#) | [Corporate Accounts](#)
[e-Books & Docs](#) | [Bargain Books](#) | [Used Books](#)

[Amazon.com Home](#) | [Directory of All Stores](#)

Our International Sites: [Canada](#) | [United Kingdom](#) | [Germany](#) | [Japan](#) | [France](#)

[Contact Us](#) | [Help](#) | [Shopping Cart](#) | [Your Account](#) | [Sell Items](#) | [1-Click Settings](#)

[Investor Relations](#) | [Press Releases](#) | [Join Our Staff](#)

[Conditions of Use](#) | [Privacy Notice](#) © 1996-2004, Amazon.com, Inc. or its affiliates

Search:

Browse:

You clicked on this item...

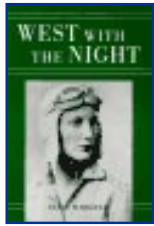

West With the Night

by [Beryl Markham](#)

Average Customer Review: 
Usually ships in 24 hours



Eligible for **FREE Super Saver Shipping** on orders over \$25. [See details.](#)

Price: \$11.20
You Save: \$2.80 (20%)

1018 used & new from **\$0.36**

Amazon.com

Or [buy used](#): **\$0.36**

One of the most beautifully crafted books I have ever read, with some of the most poetic prose passages I could imagine, such as the following, resonating with a stately and timeless quality so absent in our modern life:

There are all kinds of silences and each of them means a different thing.

... [Read more](#)

You may also be interested in these items...

[Customers also shopped for](#)

Show items from:

▶ **All Products**

[Books](#) (20)

[DVD](#) (13)

[Music](#) (10)

[Video](#) (2)



The Lives of Beryl Markham

by Errol Trzebinski, Errol Trzebinski

[More like this](#)



The Flame Trees of Thika

by Elspeth Huxley

[More like this](#)



Out of Africa and Shadows on the Grass (Vintage International)

by Isak Dinesen

[More like this](#)



Wind, Sand and Stars

by Antoine de Saint-Exupery

[More like this](#)

Straight on Till Morning

by Mary S. Lovell

[More like this](#)



Out of Africa (Modern Library)

by ISAK DINESEN

[More like this](#)

	<p>Splendid Outcast by Beryl Markham, Mary S. Lovell</p> <p>More like this</p>	 <p>Arabian Sands (Travel Library) by Wilfred Thesiger</p> <p>More like this</p>	 <p>Isak Dinesen by Judith Thurman</p> <p>More like this</p>
--	---	--	--









[More results](#) ▶

<p>New at Amazon.com Visit our new Seasonal Tableware Store and save up to 40% on Lenox, Spode, and more.</p>	<p>\$25 Off Tools & Hardware Take \$25 off when you spend \$199 or more on Tools & Hardware products offered by Amazon.com. Here's how (restrictions apply).</p> <p>\$25 Offer</p>	<p>New at Amazon.com</p>  <p>Find more than 600,000 china, crystal, and silver products in the Replacements, Ltd. Store.</p> <p>REPLACEMENTS LTD.</p>
--	--	--

<p>Where's My Stuff?</p> <ul style="list-style-type: none"> Track your recent orders. View or change your orders in Your Account. 	<p>Shipping & Returns</p> <ul style="list-style-type: none"> See our shipping rates & policies. Return an item (here's our Returns Policy). 	<p>Need Help?</p> <ul style="list-style-type: none"> Forgot your password? Click here. Redeem or buy a gift certificate. Visit our Help department.
--	--	---

Search **for**

Your Recent History
[Learn More](#)

<p>Recently Viewed Products</p> <ul style="list-style-type: none">  The Mirror of the Sea by Joseph Conrad  The Cruise of the Snark by Jack London  Sailing by Henry Beard, Roy McKie  Voyage of Rediscovery by Ben R. Finney, Ben Finney  The Last Navigator by Stephen D. Thomas <p>▶ Visit the Page You Made</p>	<p>Customers who bought items in your Recent History also bought:</p> <div style="display: flex; justify-content: space-around;"> <div data-bbox="836 1333 1185 1596">  <p> We, the Navigators by David Lewis, Derek, Sir Oulton</p> </div> <div data-bbox="1201 1333 1567 1596">  <p> Cooking by Henry Beard, Roy McKie</p> </div> </div>
---	--

Turn your past books purchases into \$\$\$
[Learn more](#) about selling at Amazon.com today!

[Books Search](#) | [Browse Subjects](#) | [Bestsellers](#) | [Magazines](#) | [Corporate Accounts](#)
[e-Books & Docs](#) | [Bargain Books](#) | [Used Books](#)

[Amazon.com Home](#) | [Directory of All Stores](#)

Our International Sites: [Canada](#) | [United Kingdom](#) | [Germany](#) | [Japan](#) | [France](#)

[Contact Us](#) | [Help](#) | [Shopping Cart](#) | [Your Account](#) | [Sell Items](#) | [1-Click Settings](#)

[Investor Relations](#) | [Press Releases](#) | [Join Our Staff](#)

[Conditions of Use](#) | [Privacy Notice](#) © 1996-2004, Amazon.com, Inc. or its affiliates



Search: Browse:

You clicked on this item...

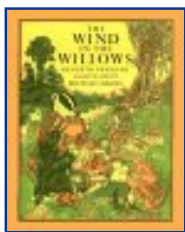

The Wind in the Willows

by Kenneth Grahame, Michael Hague

Average Customer Review: ★★★★★

Out of stock

55 used & new from \$3.00

Or buy used: \$3.00

Amazon.com

"[Mole] thought his happiness was complete when, as he meandered aimlessly along, suddenly he stood by the edge of a full-fed river. Never in his life had he seen a river before--this sleek, sinuous, full-bodied animal, chasing and chuckling, gripping things with a gurgle and leaving them with... Read more

You may also be interested in these items...

Customers also shopped for

Show items from:

- All Products
Books (20)
DVD (19)
Music (1)
Software (1)
Video (9)

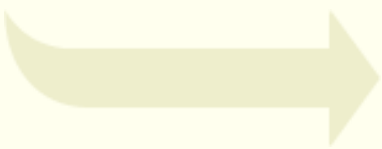

The Secret Garden by Frances Hodgson Burnett

More like this



Charlotte's Web (Trophy Newbery)

by E. B. White, Garth Williams

More like this



Just So Stories (Books of Wonder)

by Rudyard Kipling

More like this



The Willows in Winter

VHS

More like this



Stuart Little

by E. B. White

More like this



Jungle Book

by Rudyard Kipling

More like this

	 <p><u>A Wrinkle in Time</u> by Madeleine L'Engle More like this</p>	 <p><u>James and the Giant Peach</u> by Roald Dahl, Lane Smith More like this</p>	 <p><u>The Lion, the Witch and the Wardrobe (Full-Color Collector's Edition)</u> by C. S. Lewis More like this</p>
--	--	--	---









[More results](#) 

<p>New at Amazon.com Visit our new Seasonal Tableware Store and save up to 40% on Lenox, Spode, and more.</p>	<p>\$25 Off Tools & Hardware Take \$25 off when you spend \$199 or more on Tools & Hardware products offered by Amazon.com. Here's how (restrictions apply).</p>	<p>New at Amazon.com  Find more than 600,000 china, crystal, and silver products in the Replacements, Ltd. Store.</p>
--	---	---

<p>Where's My Stuff?</p> <ul style="list-style-type: none"> Track your recent orders. View or change your orders in Your Account. 	<p>Shipping & Returns</p> <ul style="list-style-type: none"> See our shipping rates & policies. Return an item (here's our Returns Policy). 	<p>Need Help?</p> <ul style="list-style-type: none"> Forgot your password? Click here. Redeem or buy a gift certificate. Visit our Help department.
--	--	---

Search **for**

Your Recent History
[Learn More](#)

<p>Recently Viewed Products</p> <ul style="list-style-type: none">  West With the Night by Beryl Markham  The Mirror of the Sea by Joseph Conrad  The Cruise of the Snark by Jack London  Sailing by Henry Beard, Roy McKie  Voyage of Rediscovery by Ben R. Finney, Ben Finney 	<p>Customers who bought items in your Recent History also bought:</p> <table border="1"> <tr> <td data-bbox="836 1402 1177 1659">  <p> Cooking by Henry Beard, Roy McKie</p> </td> <td data-bbox="1193 1402 1567 1659">  <p> We, the Navigators by David Lewis, Derek, Sir Oulton</p> </td> </tr> </table>	 <p> Cooking by Henry Beard, Roy McKie</p>	 <p> We, the Navigators by David Lewis, Derek, Sir Oulton</p>
 <p> Cooking by Henry Beard, Roy McKie</p>	 <p> We, the Navigators by David Lewis, Derek, Sir Oulton</p>		

[Visit the Page You Made](#)

Turn your past books purchases into \$\$\$
[Learn more about selling at Amazon.com today!](#)

[Books Search](#) | [Browse Subjects](#) | [Bestsellers](#) | [Magazines](#) | [Corporate Accounts](#)
[e-Books & Docs](#) | [Bargain Books](#) | [Used Books](#)

[Amazon.com Home](#) | [Directory of All Stores](#)

Our International Sites: [Canada](#) | [United Kingdom](#) | [Germany](#) | [Japan](#) | [France](#)

[Contact Us](#) | [Help](#) | [Shopping Cart](#) | [Your Account](#) | [Sell Items](#) | [1-Click Settings](#)

[Investor Relations](#) | [Press Releases](#) | [Join Our Staff](#)

[Conditions of Use](#) | [Privacy Notice](#) © 1996-2004, Amazon.com, Inc. or its affiliates

[Skip navigation](#)

Products Solutions Support Purchase Company

Search Contact Us

Acrobat family

Simplify business document processes



Whether you need to share files across the office or around the world, the Adobe® Acrobat® product family enables businesses to simplify document processes using Adobe Portable Document Format (PDF). A standard adopted by governments and enterprises worldwide, Adobe PDF is a reliable format for electronic document exchange that preserves document integrity so files can be viewed and printed on a variety of platforms.

[Enterprise solutions](#)

[contact an Acrobat sales rep](#)

View the animated Acrobat 6.0

[tour](#) Professional tour ([Flash: 3-8 min](#))

[tryout](#) Acrobat 6.0 Professional

What do you need to do?

Get advanced control over document exchange and output

[Acrobat 6.0 Professional](#) software offers the most advanced control over document exchange, review, and output.

Streamline business document exchange and review

Highlights

New [Adobe Acrobat 6.0](#)

[Professional tryout](#)

Download your free 30-day tryout and experience how easy it is to create, exchange, review, and archive Adobe PDF documents.

[Want customized Acrobat information?](#)

Register for access to a one-stop online Acrobat 6.0 toolkit where you can view animated tours, FAQs, online seminars, customer stories, and more.

[Acrobat 6.0 Standard](#) software streamlines business document exchange and review.

Standardize document distribution across the enterprise

[Acrobat Elements 6.0](#) software allows enterprises to standardize on Adobe PDF for document distribution (volume licensing only). A [server version](#) is also available.

View and print Adobe PDF files

Free **[Adobe Reader®](#)** software lets anyone view and print Adobe PDF files. Adobe has distributed more than 500 million copies of the software worldwide.

[Which product is right for you?](#)

Compare the features of Adobe Acrobat 6.0 Professional, Standard, and Elements.

Acrobat 6.0 Professional and Acrobat 6.0 Standard are now available for purchase as downloads. Order and download today. [See details.](#)

[New product reviews](#)

Read the latest reviews on the Acrobat 6.0 family of products.



Copyright © 2004 Adobe Systems Incorporated. All rights reserved.

- [Terms of Use](#)
- [Privacy Policy](#)
- [Accessibility](#)
- [Avoid software piracy](#)
- [Permissions and trademarks](#)
- [Product License Agreements](#)



HO 249 Sight Worksheet: Stars

Star Finding Data

GMT at Twilight m__d__h__m__
DR Lat ___°___' DR Long ___°___'
LHA Υ ___°

Star: _____

Alt ___°___' Zn ___

Sight

IC ___ HE ___

Altitude

Hs: ___°___.

IC \pm ___.

dip - ___.

Ha: = ___°___.

Corr \pm ___.

Ho: = ___°___.

Time

LT __m__d__h__m__s

Zone \pm __h

Watch corr \pm __s

UT: __m__d__h__m__s

Almanac

GHA Υ dh ___°___.

Υ ms + ___°___.

GHA Υ = ___°___.

Assm Long ___°___.

LHA Υ ___°

Assm Lat ___°

HO 249

Hc ___°___.

Ho ___°___.

Dist ___°___ A or T

Zn ___

Star: _____

Alt ___°___' Zn ___

Sight

IC ___ HE ___

Altitude

Hs: ___°___.

IC \pm ___.

dip - ___.

Ha: = ___°___.

Corr \pm ___.

Ho: = ___°___.

Time

LT __m__d__h__m__s

Zone \pm __h

Watch corr \pm __s

UT: __m__d__h__m__s

Almanac

GHA Υ dh ___°___.

Υ ms + ___°___.

GHA Υ = ___°___.

Assm Long ___°___.

LHA Υ ___°

Assm Lat ___°

HO 249

Hc ___°___.

Ho ___°___.

Dist ___°___ A or T

Zn ___

Star: _____

Alt ___°___' Zn ___

Sight

IC ___ HE ___

Altitude

Hs: ___°___.

IC \pm ___.

dip - ___.

Ha: = ___°___.

Corr \pm ___.

Ho: = ___°___.

Time

LT __m__d__h__m__s

Zone \pm __h

Watch corr \pm __s

UT: __m__d__h__m__s

Almanac

GHA Υ dh ___°___.

Υ ms + ___°___.

GHA Υ = ___°___.

Assm Long ___°___.

LHA Υ ___°

Assm Lat ___°

HO 249

Hc ___°___.

Ho ___°___.

Dist ___°___ A or T

Zn ___

HO 249 Sight Worksheet: Solar System

Date: ___/___/___ Miles Run Last Position _____ Course _____

DR Lat ___° ___' DR Long ___° ___'

Object: _____

Sight

IC ___ HE ___

Altitude

Hs: ___° ___'.

IC ± ___'.

dip - ___'.

Ha: = ___° ___'.

Corr ± ___'.

Ho: = ___° ___'.

Time

LT ___m ___d ___h ___m ___s

Zone ± ___h

Watch corr ± ___s

UT: ___m ___d ___h ___m ___s

Almanac

GHA

mn-dy-hr ___° ___'.

min-sec + ___° ___'.

v ___ corr ± ___'.

GHA: = ___° ___'.

Declination

mn-dy-hr ___° ___'.

d ___ corr ± ___'.

Decl: = ___° ___'.

Calculations

Assm Long ___° ___'.

LHA

Assm Lat ___°

Assm Dec ___°

Dec Remainder ___.

HO 249

Hc ___° ___' d ___ Z ___

Corr ± ___ Zn ___

Hc ___° ___'.

Ho ___° ___'.

Dist ___ A or T

Object: _____

Sight

IC ___ HE ___

Altitude

Hs: ___° ___'.

IC ± ___'.

dip - ___'.

Ha: = ___° ___'.

Corr ± ___'.

Ho: = ___° ___'.

Time

LT ___m ___d ___h ___m ___s

Zone ± ___h

Watch corr ± ___s

UT: ___m ___d ___h ___m ___s

Almanac

GHA

mn-dy-hr ___° ___'.

min-sec + ___° ___'.

v ___ corr ± ___'.

GHA: = ___° ___'.

Declination

mn-dy-hr ___° ___'.

d ___ corr ± ___'.

Decl: = ___° ___'.

Calculations

Assm Long ___° ___'.

LHA

Assm Lat ___°

Assm Dec ___°

Dec Remainder ___.

HO 249

Hc ___° ___' d ___ Z ___

Corr ± ___ Zn ___

Hc ___° ___'.

Ho ___° ___'.

Dist ___ A or T

Object: _____

Sight

IC ___ HE ___

Altitude

Hs: ___° ___'.

IC ± ___'.

dip - ___'.

Ha: = ___° ___'.

Corr ± ___'.

Ho: = ___° ___'.

Time

LT ___m ___d ___h ___m ___s

Zone ± ___h

Watch corr ± ___s

UT: ___m ___d ___h ___m ___s

Almanac

GHA

mn-dy-hr ___° ___'.

min-sec + ___° ___'.

v ___ corr ± ___'.

GHA: = ___° ___'.

Declination

mn-dy-hr ___° ___'.

d ___ corr ± ___'.

Decl: = ___° ___'.

Calculations

Assm Long ___° ___'.

LHA

Assm Lat ___°

Assm Dec ___°

Dec Remainder ___.

HO 249

Hc ___° ___' d ___ Z ___

Corr ± ___ Zn ___

Hc ___° ___'.

Ho ___° ___'.

Dist ___ A or T

Neu:
SPIEL-
WAREN

Beta (Was bedeutet das?)

HOME

MEIN SHOP

BÜCHER

ENGLISH BOOKS

ELEKTRONIK & FOTO

MUSIK

DVD

VHS

SOFTWARE

PC- & VIDEO-SPIELE

KÜCHE, HAUS & GÄRTEN

SPIELWAREN & KINDERWELT

NEU

International

Gutscheine

Preis-
HitsGeld
verdienen!

SCHNELLSUCHE ▶

Kostenlose Lieferung ab 20 EUR. Für kurze Zeit: Bücher versandkostenfrei! [Mehr dazu.](#)

Angebot der Woche

Riddick

Nicht verpassen,
jetzt vorbestellen:
[Riddick - Chroniken
eines Kriegers](#) auf

DVD.

Preis: **EUR 19,99****Hallo.** Sind Sie Neukunde? [Hier geht's los.](#)

Elektronik-Megastore

**Topseller bis zu 50% reduziert!** [Hier klicken!](#)**Muggels aufgepasst: Jetzt für Neuigkeiten zu Harry Potter 6 (deutsch) und (englisch) registrieren!****Elektronik-Megastore: 8x-DVD-Brenner ab 79 EUR!**Der [LG GSA-4120B-R](#) brennt alle gängigen DVD-Formate sowie DVD-RAM mit bis zu 12-facher Geschwindigkeit.**Amazon-Preis: EUR 98,90****Alle Angebote** ab **EUR 97,99****Versandkostenfrei!**

- [Megastore -- Topseller bis zu 50% reduziert](#)
- [8x-DVD-Brenner ab 79 EUR](#)
- [DVD-Player ab 39,99 EUR](#)

Jazz CDs bis zu 30% reduziertStöbern Sie in unserer großen Aktion: [Über 1.000 Jazz-CDs](#) jetzt bis zu 30% reduziert!

- Norah Jones: [Come Away With Me](#) Preis: **EUR 11,97**
- Norah Jones: [Feels Like Home](#) Preis: **EUR 12,99**
- Miles Davis: [Kind of Blue](#) Preis: **EUR 6,99**
- Dave Brubeck Quartet: [Time Out](#) Preis: **EUR 6,99**

Jetzt zugreifen!Topseller zu Spitzenpreisen:
[Kaffee- & Espressomaschinen](#)
bis zu 35% reduziert!**Musik-Preis-Hits**[1.000 CDs für je 6,99 EUR.](#)

Unsere Shops

Buch, Musik & DVD

- [Bücher](#)
- [English Books](#)
- [Zeitschriften](#)
- [Musik](#)
- [DVD](#)
- [Video](#)

Elektronik & PC

- [Elektronik](#)
- [Kamera & Foto](#)
- [Computer & Zubehör](#)
- [PC- & Videospiele](#)
- [Software](#)

Haus & Garten

- [Küche & Haushalt](#)
- [Garten & Freizeit](#)
- [Heimwerken](#)
- [Körperpflege & Bad](#)

Spielwaren & Kinderwelt

- [Spielwaren](#)
- [Kinderbücher](#)
- [Kinder-DVDs](#)

Geschenke & E-Cards

- [Geschenke](#)
- [E-Cards](#)

Günstige Angebote

- [Gebraucht-Shop](#)
- [Auctions](#)
- [zShops](#)

NEU FÜR SIE

Sie sind bereits Kunde?
Bitte melden Sie sich an und werfen Sie einen Blick in **Neu für Sie.****Ihr Einkaufswagen**Sie haben 0 Artikel in [Ihrem Einkaufswagen.](#)**Neuerscheinungen**[2004 Athen - Das Olympiabuch](#)**Weitere Kategorien**

- [Reise & Sport](#)
- [Originalfassungen](#)
- [Film, Kultur & Comics](#)
- [Pop](#)
- [Computer & Internet](#)

▶ **Weitere Neuerscheinungen**

€ Make Money

Partnerprogramm

Geld verdienen mit Ihrer Website

Amazon Web Services

Erstellen Sie Websites, Applikationen oder Tools mit Amazon Web Services

Jetzt verkaufen!

Kostenlos Artikel zum Verkauf anbieten. Schnell und einfach!

► [Das lohnt sich!](#)

Endlich: Fritz und Fertig 2!



Nach dem schier unglaublichen Erfolg von [Fritz und Fertig! - Schach für Kinder](#) gibt es jetzt endlich den Nachfolger [Fritz und Fertig! Schach für Kinder - Folge 2](#) mit besonderem Schwerpunkt auf Schachstrategien und -taktiken! Weitere drastisch reduzierte Top-Software finden Sie im aktuellen [Elektronik-Megastore](#).

Tiefpreise bei Büchern



Jeden Tag über 50% sparen! Ob reduzierte Hörbücher, günstige Taschenbücher oder Restexemplare: Dieses und mehr zu dauerhaften Tiefpreisen finden Sie in unseren [Preis-Hits](#).

unverb. Preisempf.: EUR 99,95 / **Amazon-Preis:** **EUR 59,95**
/ **Sie sparen:** **EUR 40,00 (40%)** /
Alle Angebote ab **EUR 52,00**

Hier unsere Top-Angebote:

- [Von Harry Potter bis Der Herr der Ringe: Top-Hörbücher jetzt radikal reduziert!](#)
- [Über 2.000 Reste & Schnäppchen bis 3 EUR!](#)
- [Die besten Taschenbücher im September!](#)



In Musik: Viel Musik für wenig Geld: CD-Box-Sets ab 9,97 EUR!



In Bücher: Jetzt neu bei Amazon.de: die aktuellen Bestseller des SPIEGEL-Magazins!



In Elektronik: Restposten und Top-Neuheiten reduziert im [Megastore!](#)

Entdecken

Sicherheitsgarantie

Ihre Sicherheit steht bei uns an erster Stelle

Kaufen & Zahlen

Zahlungsmöglichkeiten bei Amazon.de

Geschenkservice

So macht Schenken noch mehr Spaß

Rezensions-Gewinnspiel

Wer zuerst schreibt, gewinnt!

Amazon.de mobil

Mobil einkaufen mit Ihrem Handy

Lieferung frei Haus!



[Kostenlose](#)

[Lieferung](#) ab 20,00

EUR Bestellwert. Nur für kurze Zeit: Bücher versandkostenfrei!

Die Amazon

Hot 100 Bücher

Topseller stündlich neu!

1. [Der Dativ ist dem Genitiv sein Tod](#) -- von Bastian Sick -- **EUR 8,90**
2. [Illuminati](#) -- von Dan Brown -- **EUR 8,90**
3. [Vollidiot](#) -- von Tommy Jaud -- **EUR 12,90**

► [Zur gesamten Liste](#)

Hot 100 Musik

Topseller stündlich neu

1. [Pur Klassisch-Live Aufschalke](#) -- von Pur -- **EUR 13,99**
2. [Reise Reise Ltd. Edt](#) -- von Rammstein -- **EUR 15,99**
3. [Confidence](#) -- von Gentleman -- **EUR 13,99**

► [Zur gesamten Liste](#)

Hot 100 DVD

Topseller stündlich neu

1. [Star Wars Trilogie \(4 DVDs\)](#) -- **EUR 47,99**
2. [Troja \(2 DVDs\)](#) -- **EUR 19,99**
3. [Van Helsing \(Collector's Edition, 2 DVDs\)](#) -- **EUR 22,99**

► [Zur gesamten Liste](#)

• **Wo ist meine Bestellung?**

- Alle Informationen zu Ihren [letzten Bestellungen](#)
- Bearbeiten oder überprüfen Sie Ihre offenen Bestellungen in "[Mein Konto](#)".

Versand & Rücknahme

- Unsere [Versandbedingungen](#) und unsere [Sicherheitsgarantie](#)
- Geben Sie einen Artikel [zurück](#) (lesen Sie hier unsere [Rücknahmegarantie](#))

Brauchen Sie Hilfe?

- [Haben Sie Ihr Passwort vergessen?](#)
- [Lösen](#) Sie einen Geschenkgutschein ein -- oder [verschenken](#) Sie einen
- Besuchen Sie unsere [Hilfeseiten](#).

Schnellsuche

[Textversion](#)

[Zum Seitenanfang](#)

**Verwandeln Sie Ihre bisherigen Käufe in bare Münze!
[Erfahren Sie mehr zum Verkaufen über Amazon.de.](#)**

[Amazon.com](#) | [Amazon.co.uk](#) | [Amazon.fr](#) | [Amazon.co.jp](#) | [Amazon.at](#) | [Amazon.ca](#)

[Schließen Sie sich den Amazon.de-Partnern an](#) | [Über Amazon.de](#) | [Jobs bei Amazon.de](#) | [Kontakt](#)

[Unsere AGBs](#) | [Datenschutzerklärung](#) | [Impressum](#) © 1998-2004, Amazon.com, Inc. und Tochtergesellschaften



English Version



navastro .fr



Le site web de la Navigation Astronomique

[Service](#) [Contact](#) [Panier](#) [Accueil](#)

➤ [Catalogue](#)

➤ [Sextants](#)

- [Sunwatch](#)
- [Davis](#)
- [Astra](#)
- [Freiberger](#)
- [Cassens & Plath](#)
- [Tamaya](#)
- [Sextants de Décoration](#)

➤ [Accessoires](#)

- [Pièces détachées](#)

➤ [Chronomètres](#)

➤ [Livres](#)

- [Initiation](#)
- [Perfectionnement](#)
- [Tables de calculs](#)
- [Ephémérides](#)
- [Astronomie](#)
- [Histoire](#)

➤ [Calculatrices](#)

➤ [Matériel de table à cartes](#)

➤ [Accessoires d'astronomie](#)

➤ [Stages de Formation](#)



du 15 au 20 septembre 2004,
à La Rochelle
nous vous présenterons nos stages sur
LOLA of SKAGEN
(Bateau traditionnel amarré au
Village Bois)



Excellente technicité au meilleur prix

- Chassis en aluminium anti-corrosion
- Eclairage par LEDs sur le tambour et le limbe
- Miroir d'index rectangulaire et argenté sur la face avant
- Malette de transport en bois verni
- Livré avec lunette 3.5x40

Sextant identique au modèle ref. 2300020, mais avec la lunette à prisme 6x30 (ref. 2310509) en standard.



→ [La navigation astro, comment ça marche ?](#)

→ [Comment choisir un sextant ?](#)

→ [Comment commander ?](#)

→ [CNIL](#)

→

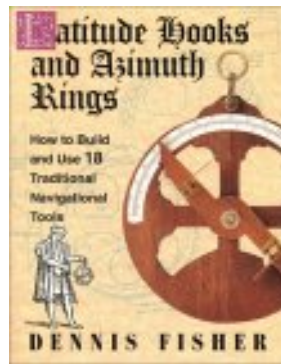

par Dennis Fisher

Ce livre en anglais présente 18 accessoires de navigation ancienne, explique comment les construire facilement (en bois) et donne des explications très intéressantes sur leur usage.

Il passionnera les amateurs d'instruments anciens qui pourront découvrir très pratiquement leur fonctionnement réel.

Illustré de très nombreux schémas très clairs.

Calculatrice scientifique programmable graphique.

Affichage monochrome 6 lignes de 13 car.

Mémoire RAM 24 Ko

Connectable (câble en option)

Entièrement programmée pour la Navigation
Astronomique



© Site réalisé par [i-beez](#)

navastro est une marque déposée



The ASNAv Home Page



What is ASNAv?

[Click here for an introduction to Celestial Navigation](#)

[Click here to buy the program](#)

ASNAv is an astronomic navigation program written by a Merchant Navy officer.

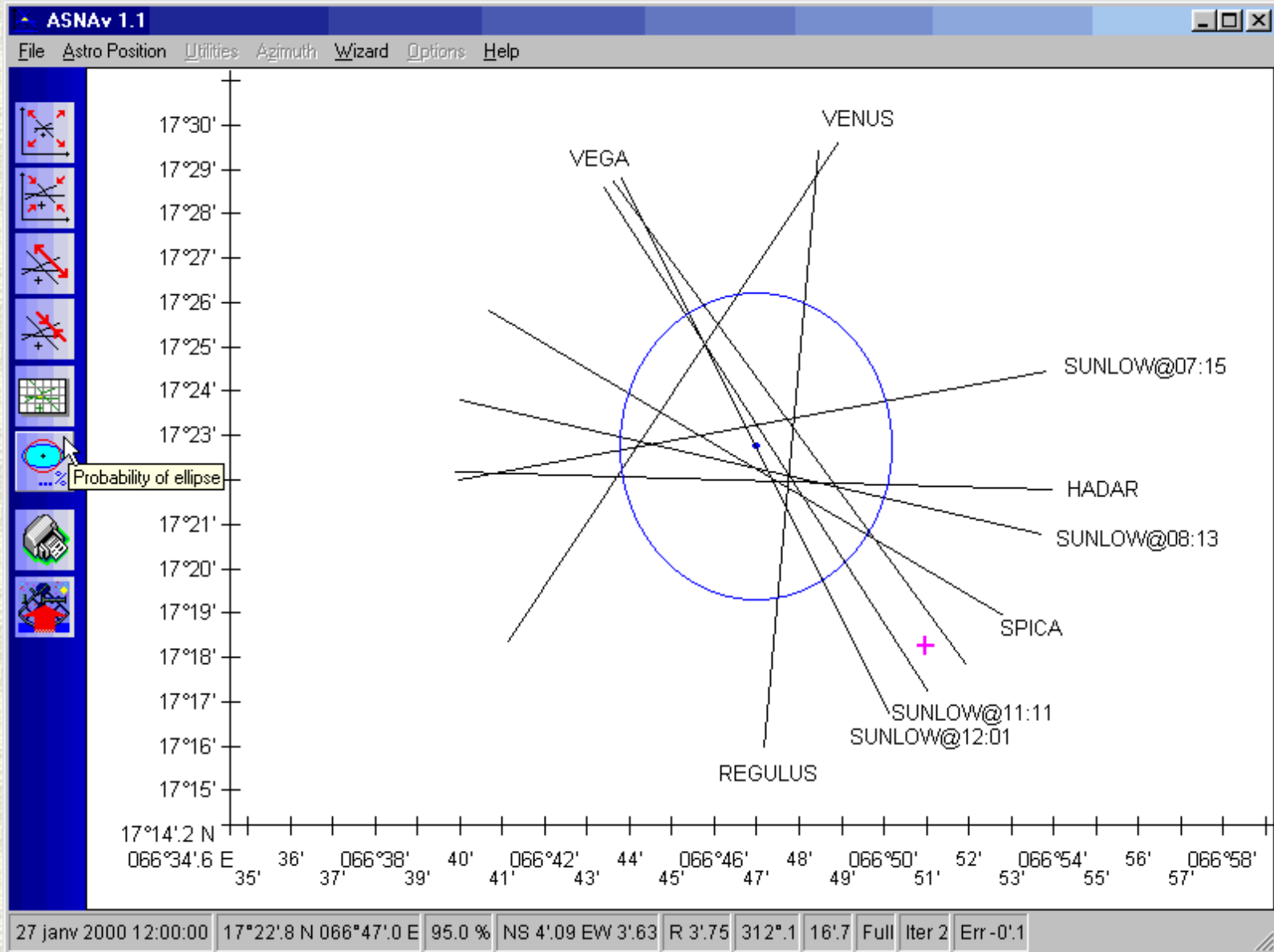

ASNAv calculates the user position by means of stars observations. A nautical almanac is not required.

The user enters only his estimated position and sextant altitudes of heavenly bodies (stars, planets, sun, moon). The program computes and plots (see example) the most probable position and an ellipse of probability around it, together with the lines of position (LOPs).

What's New

ASNAv is something **new** in the world of celestial

navigation programs.

Because ASNAv is designed by a seaman for seamen.

The program aims to be a practical option as backup of the today omnipresent GPS. This means that ASNAv is trying to decrease the additional workload to a minimum. There is nearly no time consumed outside the time required for the observations themselves. ASNAv is written by a Merchant Navy chief officer and is user-friendly from a seaman point of view.

Because ASNAv is definitely smarter than the existing astronavigation programs.

Indeed, a **statistical analysis** is performed:

- each observation can include some small errors due to a bad horizon, clouds or the ship's rolling during the measure. It is difficult to estimate oneself the quality of a given observation because the small errors can counterbalance each other. That's why ASNAv gives a **certain weight to each observation** according to its reliability in the normal law model.
- very often an observer is repeating a same constant error for each observation (uncorrected sextant index error and personal error). This possible **systematic error** of the observer can be computed and eliminated;
- the program can also **correct the assumed course and speed** if enough observations are provided (exactly the same way the GPS is able to give the course and speed of the vessel if enough satellites are visible).

This last feature can greatly improve the accuracy of the results compared with a traditional method if the exact course and speed are not known (under- or overestimated drift). However, you need at least 8 observations during 3 hours in order to make course and speed correction possible. So, it's a good idea to combine a star fix and a number of sun observations.

See an [example of the ASNAv skills](#).

ASNAv has the following characteristics too:

- it includes an accurate **nautical almanac** without limit of time;
- it computes [rhumb lines](#) on an **ellipsoid** (e.g. WGS-84) and not only on a sphere;
- [great circles](#) are also calculated on an ellipsoid (including composite sailing);
- it is able to find the [compass error](#) by means of an azimuth observation;
- a [star fix wizard](#) helps to prepare the stars observations;
- it computes [ETA](#) (Estimated Time of Arrival) in local time.

See the [last news about the program](#).

What are the system requirements to run ASNAv?

ASNAv is a 32 bits program and it will work on any computer with Microsoft Windows 95, 98, Me, NT, 2000 or



A 256 colors display is necessary. If you are still using Windows 95, Internet Explorer 4.0 (or newer) must be installed.

There is no specific Mac version available but any Mac user can now use a Windows software emulator like "Virtual PC" to get the best of both worlds...

More details about the program?

See the [on-line manual](#).

Why celestial navigation?

How much people who are sailing the high seas today entrust the sole GPS with the care of their life? What if something comes wrong with

this wonderful instrument?

Ten years ago, there was backup available: the old satellite Transit system (shut down in December 1996), the hyperbolic Omega stations (closed in October 1997) or the Decca chains (no longer running in UK since 2000). Today, if you aren't within range of the Loran-C (mainly along the US coasts), you are lost... except if there is a sextant on board and if you know how to use it.

[Celestial navigation](#) is an independent, low-cost, worldwide method for positioning. Observe a star altitude with the sextant is easy and can be learned quickly with a little training. Making by hand the calculations to get finally his position on the chart is harder. But today a third way exists: using astronomic navigation software for the calculations. More and more seafarers have already a laptop computer on board. Why not using it for [celestial navigation](#)? It's very satisfying to practise one of the most ancient science and it is much more safe than "GPS only" navigation.

The choice for the sextant is big. Some plastic sextants are enough accurate to start and cost about 100 US\$ (e.g. Davis Mark 15). It's the price of your real independence on the high seas...

[Celestial navigation](#) is one ideal subject for any yachtsman who wants to broaden his knowledge of the "art of navigation". ASNAv will take care of the boring mathematics and just keeps the fun of celestial navigation.

On merchant ships, the daily use of the [celestial navigation](#) is decreasing. This is due to the increasing workload. Spending too much time for manual computations of a celestial position becomes really difficult. A good compromise is to go on using the celestial navigation daily but to speed up the calculations with the assistance of a computer. In case of emergency (no more power supply on board), it is still possible to use the sextant (the practice of taking observations is not lost) in combination with a concise sight reduction table like the one published in the Nautical Almanac (the official Nautical Almanac published jointly by *Her Majesty's Nautical Almanac Office, Rutherford Appleton Laboratory, England* and the *US Naval Observatory*). If it is necessary to abandon the ship, the sextant, Nautical Almanac and a good watch are enough to head the lifeboat for a coast.

If you want to learn more about [celestial navigation](#), go to [Celestial navigation for dummies](#) (an introduction to celestial navigation theory).



Last news about the program

History of the program

The first release of ASNAv was a DOS, text-only program issued in 1994 (ASNAv 0.3). In September 1997, a Windows 16 bits version appeared, ASNAv 0.4, which has still partly a text-based interface.

These versions were only distributed among my friends and on board of the ships of the Belgian Merchant Marine.

On 12 September 1999, the last Beta version of the program, ASNAv 0.9, was published on the Web.

After an intensive period of (successful) tests on board of the tanker fleet of my company and at the Nautical College of Antwerp, thanks to the feedback of many Internet users as well, the final release (ASNAv 1.0) was ready on 15 May 2000.

ASNAv is available from Seamanship in the 'Navigator's Assistant' package (tide calculations, passage planning, celestial navigation) since 2001.

ASNAv is available from Seamanship as a stand-alone application since April 2004.

Corrections and improvements since release 0.9



List of bugs corrected on the ASNAv 1.0 version:

1. the Star Fix Wizard didn't take into account the user's selection of stars and was sometimes crashing the program ("Subscript Out of Range" error) when going back from Step 4 to Step 3. This is fixed.
2. the Star Fix Wizard didn't take into account the height of observer eye. The stars altitudes displayed were calculated altitudes. Now, these are sextant altitudes, which means that the necessary corrections are applied (in a reverse way that usual) to obtain sextant altitudes from the calculated altitudes assumed to be the true altitudes.
3. it was sometimes no more possible to close the Star Fix Wizard. This is fixed.
4. if the program used a truncated routine due to an insufficient time spread, then the maximum time between the observations was sometimes not displayed. This is fixed.
5. if a wrong time of observation was entered in the grid (typing error like 22 Nov 1999 220012), the program crashed. This is fixed.
6. if the user tried to erase an observation by just deleting the content of the 4 cells (not by deleting the entire line) and after that he asked to compute the results, then the results were computed only with the observations above the deleted line. In addition, after this computation, the grid data's became invalid. This is fixed.
7. in the observations grid, the tooltip "Enter time in GMT" was displayed for the entire grid; now, it is displayed for the first column only.
8. if "Options - Preferences - Intercepts - Compute all the intercepts with the given estimated position" was checked, the estimated position given by the user was always used, even if the time of the given estimated position was different than the time of the true position to compute. This is fixed. If this option is checked, the given estimated position is now translated at the time of the true position before calculation of all the intercepts with this estimated position (if the option is not checked, the intercepts are calculated with an estimated position translated for each observation at the time of the observation).
Another small fix : if the same option is checked, the distance to transfer each LOP is now displayed.
9. the azimuth calculation sheet was erased if the focus was temporary given to another program. This is fixed.
10. the system time was sometimes wrongly displayed in the Options - Preferences - Time tab. This is fixed.

Note that if you want to set your computer clock in GMT time, you need to select "(GMT) Monrovia, Casablanca" which is not a Daylight Saving Time (DST) zone. If you select "(GMT) Greenwich Mean Time ; Dublin, Edinburg, London, Lisbon", the

internal GMT time will be one hour earlier than your computer clock time when DST is active.

11. the four pictures at the bottom of the screen (used to select one of the functions of ASNAv) were still active in various wrong situations (e.g. under the result screens or with the azimuth form displayed). This is fixed.
12. the middle latitude chart used to display the MPP and the LOPs had a correct scale on the screen but an incorrect scale on some printers. This is fixed.

List of improvements made to ASNAv 1.0:

1. the files with the observations data's are now compatible whatever computer used to create them (US system or local system like French).
2. the azimuth calculation sheet used symbols peculiar to Belgian ship (like /v or Cv). This is changed to more understandable terms (like true bearing, true course, ...).
3. the Star Fix Wizard identifies the [F5] key, reduces itself and gives way to the "Store current time" dialog box.
4. the splash screen can now be escaped by pressing any key.

Corrections made to ASNAv 1.01:

1. one of the last bug corrections made to ASNAv 1.0 caused a side-effect which provoked a crash when opening Utilities - ETA Calculation and which prevented from changing the system time in Options - Preferences - Time. This is corrected (24 May 2000).
2. to ease the installation process, the self-extractible zipped file *asnazip.exe* was replaced on 28 May 2000 by *asna_ins.exe*, a zipped file able to install the program automatically.

Corrections made to ASNAv 1.02:

1. there was a wrong graphic display in the South hemisphere. This is fixed.
2. on a NT system, the program was not releasing resources when closed with the upper right close box [X]. This is fixed.
3. it was possible to enter only a time of observation, without any date (e.g. 08:03:12). Due to the internal format for storing dates, the program used in this case the 30 Dec 1899 (in our example, 30 Dec 1899 08:03:12), which gave a very, very long sailing time (!) and a rhumb line calculation error (all the rhumb lines are finally crossing the Pole as you can see below).

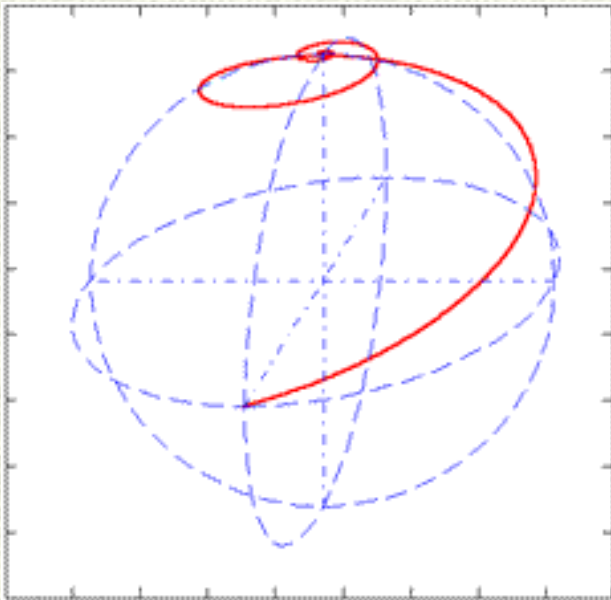

This is fixed.

4. the numeric display of the results used symbols peculiar to Belgian ship (like Hi for Hs or Hv for Ho). The terms of the Nautical Almanac are now in force.

UPDAT | Corrections & improvements made to ASNAv 1.1:

1. the moon is now supported.
2. the accuracy of the internal Nautical Almanac for Saturn is increased to the level of the other planets.
3. the azimuth calculation sheet is able to list all the visible stars at the user position (with sorting facilities).
4. a new date / time input system is implemented.
5. sometimes the great circle routine caused errors. This is fixed.
6. the observations data's entry form now allows to choose directly between round of sight or running fix for comparison with manual calculations. This is avoiding the use of the Options - Preferences... menu.
7. wrong altitudes (e.g. $40^{\circ}69'.2$) or instrumental errors entered in the observations grid could crash the program. This is fixed.
8. after accessing an observations file in a sub-directory, the help file could not be found anymore if called by the menu. This is fixed.
9. various "cosmetic" changes.

Corrections made to ASNAv 1.18:

1. when the user rejected manually the option "*Correct the course and speed if enough observations*", the program still tried to correct them if possible. This is fixed.
2. escaping the correction of sextant altitude or instrumental error in the grid with

- <Esc> gave a false indication of missing data. This is corrected.
3. entering a longitude interval of 00°00' for great circle calculation caused an error. This is fixed.
 4. the visible stars at the user position were not displayed from the azimuth calculation sheet when the user was leaving the Star Fix Wizard by <Cancel> before. This is corrected.
 5. the azimuth calculation sheet listed the altitude of the center of the moon for MOONUPP (upper limb of the moon) and MOONLOW (lower limb of the moon). The same for the Sun. The correct altitudes are now displayed in both cases.
 6. the menu 'Astro Position' - 'Erase datas' can be used to go back to the main page.
 7. new help file in html format with celestial navigation manual.

Corrections & improvements made to ASNAv 1.19:

1. enhanced html help file.
2. the program could crash when displaying the numeric results if no default printer driver was installed on the user machine. This is fixed.
3. the splash screen is replaced by a text box on computers still using Windows 95 to avoid any display problem.
4. it isn't possible anymore to enter the same departure and arrival positions for great circle calculations (1.191).
5. the ETA calculation sheet minimum speed, maximum speed and interval are limited to values which cannot generate errors (1.191).
6. small corrections of editing behaviour in great circle and ETA calculation sheets (1.192).
7. rhumb line calculations could fail if the arrival and departure latitudes were very close but not exactly equal (special case already taken into account). This happened sometimes during the calculations of intermediate rhumb lines connecting the points of a great circle. This is fixed (1.192).
8. the default time used in the observations grid is:
 - when the user press [Space] or double click the cell:
 - the computer system time saved by the stopwatch icon or [F5]
 - if not valid, the previous time in the cell
 - if not valid, the time of the same cell in the previous row
 - if not valid, the time of the estimated position
 - if not valid, the current computer date
 - when the user press another key:
 - the last edited value
 - if not valid, the current computer date (but in both cases the first digit is replaced by the pressed key if possible) (1.192).

9. the numeric results sheet is now displaying the original course and speed (before possible corrections by ASNAv algorithm). These original course and speed are also saved in the observations file (*.OBS) instead of the corrected course and speed (1.192).
10. the fields accessible by [TAB] in the observations input form (tab 1) are changed (1.193).
11. the Vertex position calculation with full accuracy could fail if very close to the departure or arrival position. This is fixed (1.194).
12. the rhumb line calculation with full accuracy could fail if the departure and arrival position were nearly equal. This is corrected (1.194).
13. help file amended (1.194).

Corrections & improvements made to ASNAv 1.2:

1. various compatibility problems in very specific cases solved (problems involving the splash screen video, the formatting of the numeric results, the communication with printers, some international settings)
2. help file amended.

Last Modified on undefined

Check this page from time to time to keep yourself informed about the progress of ASNAv 1.x

[Go back to the ASNAv home page](#)



How to use ASNAv?

Using the menu, the toolbar on the left or one of the four pictures, you can choose:

- [Astronomic position](#)
- [Utilities : rhumb line, great circle and ETA calculation](#)
- [Azimuth calculation](#)
- [Star Fix Wizard](#)

The "[Options](#)" menu lets you choose the reference ellipsoid, the estimated position(s) used to compute the LOPs and allows you to set the GMT system time.

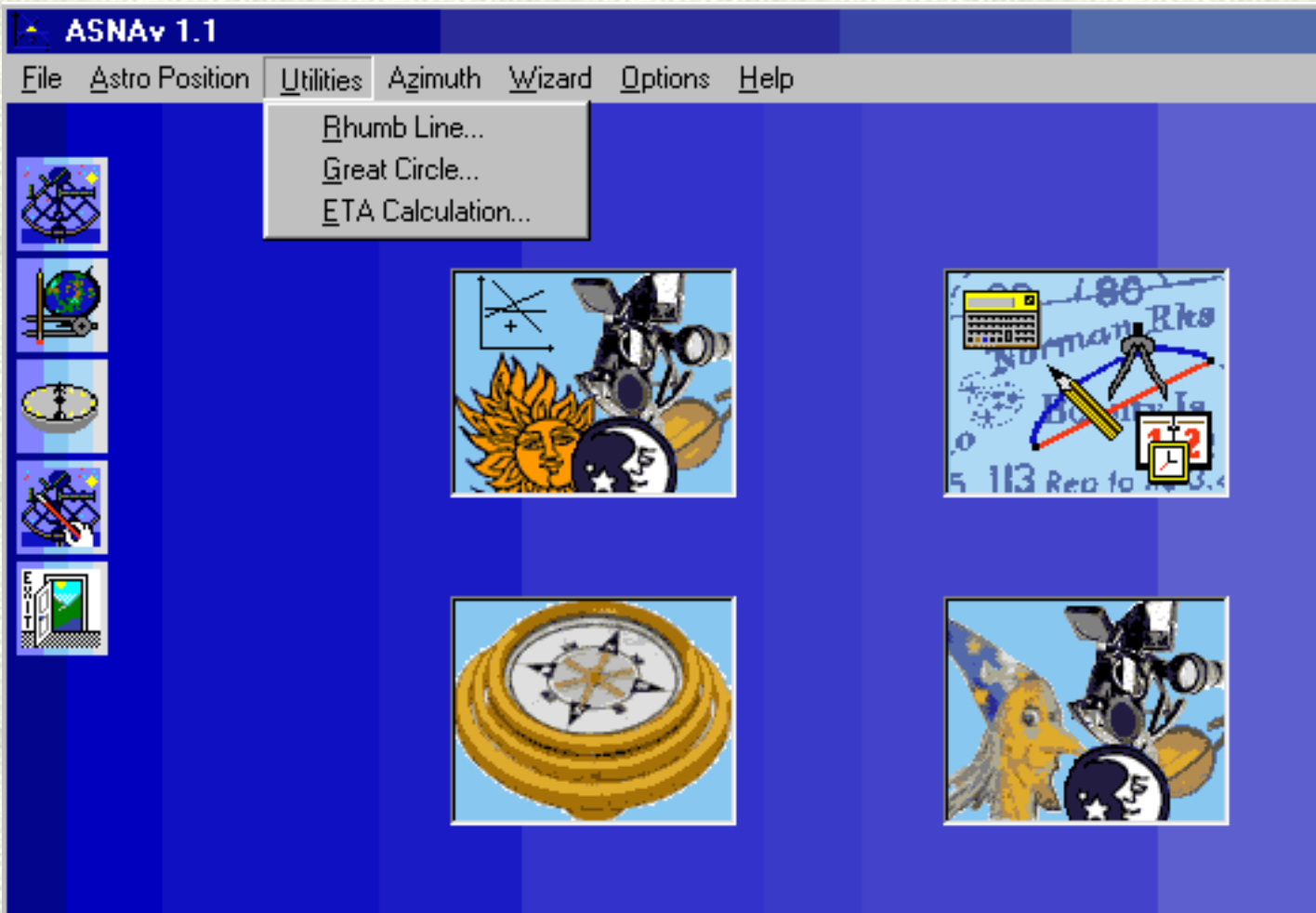

[Go back to the ASNAv home page](#)



Celestial navigation for dummies - page 2

Celestial mechanics - a blueprint (...)

Let's put an **observer** on the Earth. The point **Z** on the celestial sphere, which is directly above the head of the observer, is called his zenith. The distance on the celestial sphere between the zenith **Z** and the star **S** is the zenith distance **z**.

The zenith distance is like the distance d from the lighthouse of the previous example. We can draw a circle centred on the star S with a radius z . We are somewhere on the **projection of this circle on the Earth.** This is our new *circle of position*.

The position of the projection of the star on the Earth (latitude, longitude) and the position of the star S itself on the celestial sphere are identical (same angles,

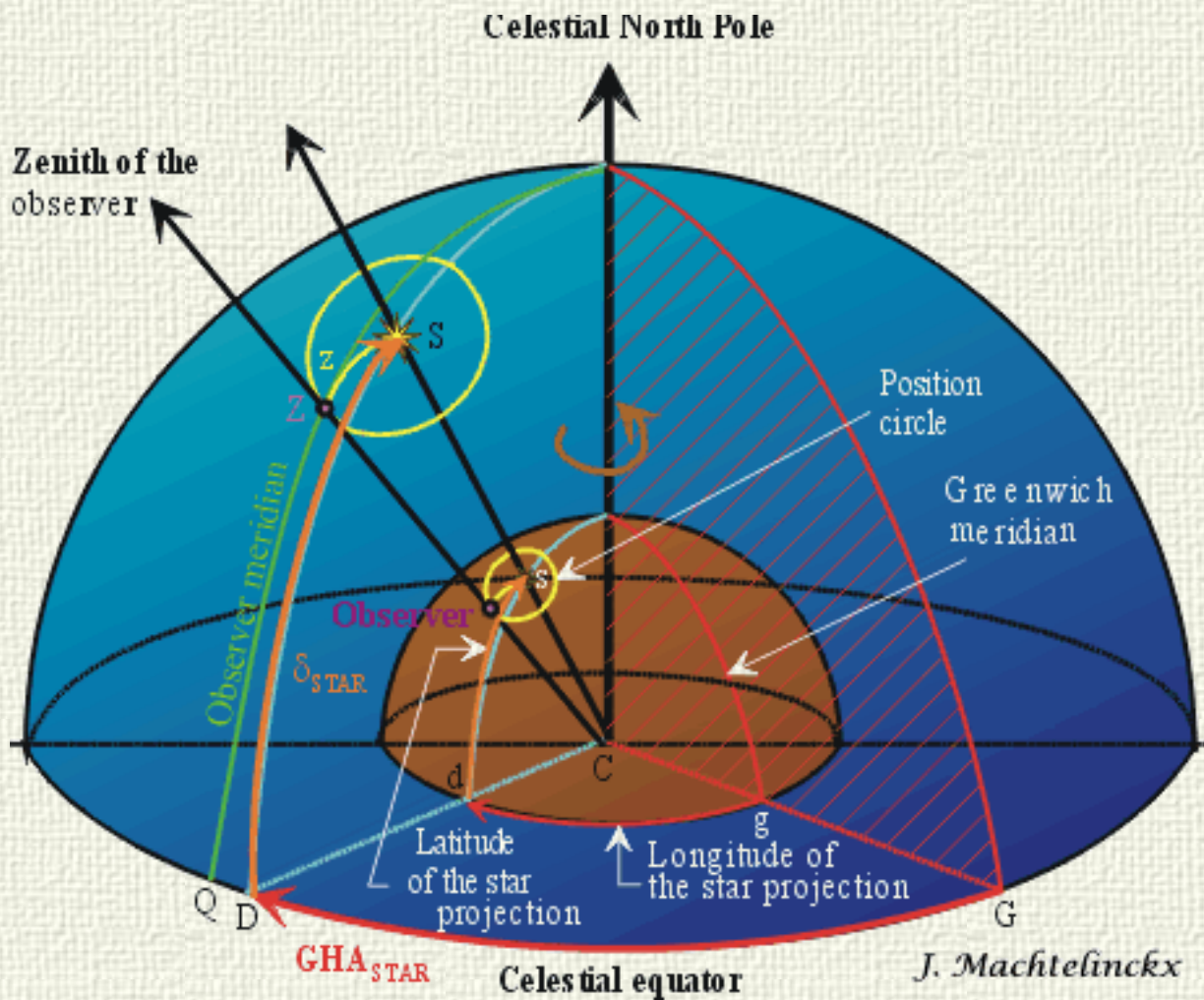

same reference plans: the celestial equator and the Greenwich meridian).

The position of the star on the celestial sphere is given by its **declination delta** ($90^\circ\text{N} - 90^\circ\text{S}$) and its

Greenwich Hour Angle (GHA), ($0^\circ - 360^\circ$). We can find both values for any given time in the Nautical Almanac (or with the kind help of [ASNAv](http://www.seamanship.co.uk/deck/navigator/ASNAv/ASNAv%20Site/Text/celnav2.htm)).

Knowing **delta** & **GHA** and measuring the zenith distance z , we can find our circle of

position and
finally our
position.

Well, very
nice... :-)
Let's enter
into the
details now.
:-)

Take the
previous
figure and
wipe-off the
surplus.
Note the
latitude and
co-latitude
($90^\circ - \text{lat}$),
the
declination
 δ and
polar
distance
 Δ ($90^\circ -$
 δ).

The figure
is using the
**equatorial
coordinate
system**
(the
reference is
the celestial
equator).
But what
we need in

fact is a reference to our local coordinate system: the **horizontal coordinate system** (the reference is the local apparent horizon).

At our position (**Observer**) on the Earth, we can imagine the **plan of our horizon** with the 4 cardinal points. If we move this plan to the centre of the Earth and redraw the figure using this plan as reference, we get the next drawing.

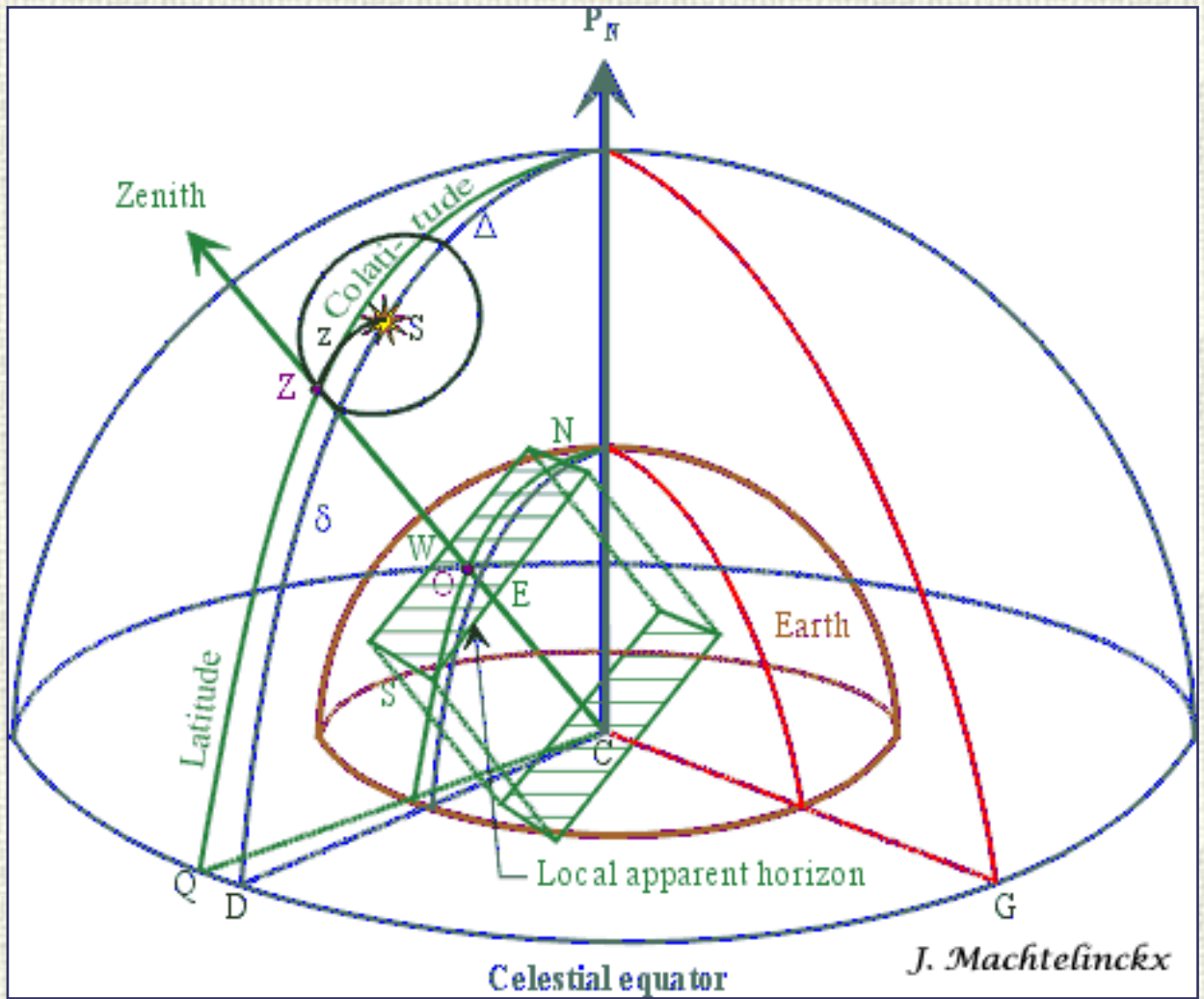

 [Previous](#) [ASNAv](#) [Next](#) 

[Go back to the ASNAv home page](#)

This Web Site and all contents are copyright © 1999-2004 by Seamanship International. All Rights Reserved.

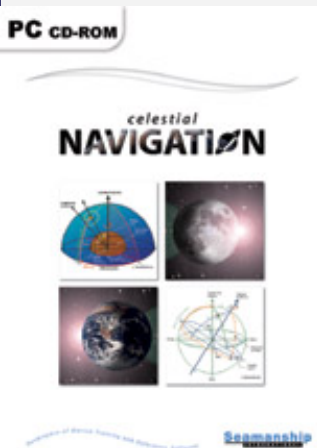
[>> CELESTIAL NAVIGATION](#)
[Click here to buy \(£49\)](#)

[Click here to download a demo](#)
[Click here to read the program manual](#)
[Click here to read an introduction to Celestial Navigation](#)

PRODUCT TYPE

[COMPANIES](#)
[DECK OFFICERS](#)
[ENGINEER OFFICERS](#)
[YACHTING](#)

This program calculates the user's position by means of stars observations. A **nautical almanac is not required**.

The user enters only his estimated position and sextant altitudes of heavenly bodies (stars, planets, sun, moon). The program computes and plots the most probable position and an **ellipse of probability** around it, together with the lines of position (**LOPs**).

A **statistical analysis** is performed:

- each observation can include some small errors due to a bad horizon, clouds or the ship's rolling during the measure. It is difficult to estimate oneself the quality of a given observation because the small errors can counterbalance each other. That's why the ASNAv program gives a **certain weight to each observation** according to its reliability in the normal law model.
- very often an observer is repeating a same constant error for each observation (uncorrected sextant index error and personal error). This possible **systematic error** of the observer can be computed and eliminated;
- the program can also **correct the assumed course and speed** if enough observations are provided (exactly the same way the GPS is able to give the course and speed of the vessel if enough satellites are visible).

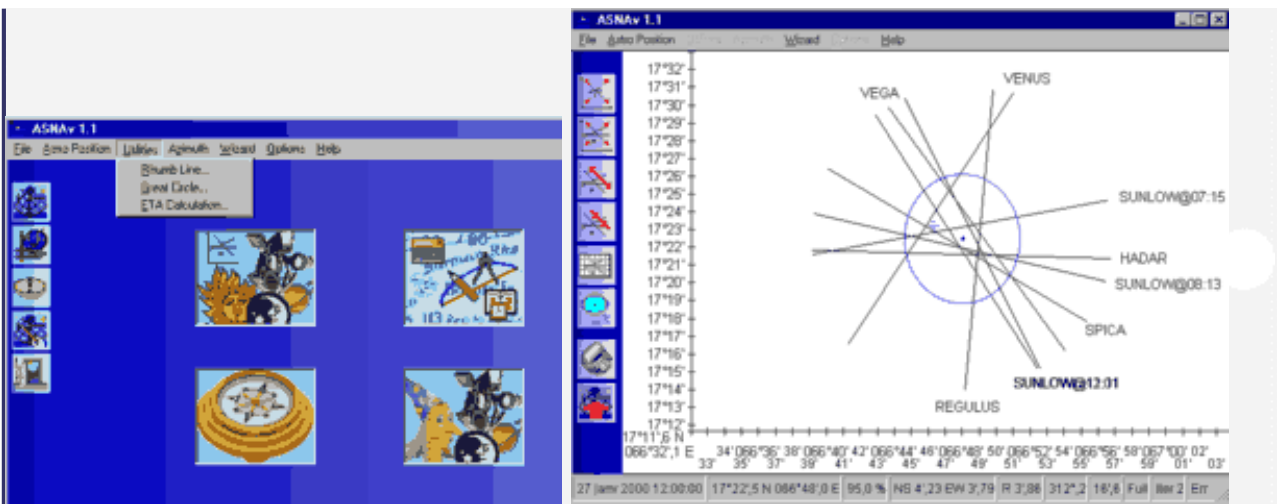

Additional features:

- **Star fix wizard** to help prepare for star observations
- Compass errors - **Azimuth calculations**
- Single **rhumb line**, **great circle** and composite great circle calculations on **ellipsoid** (e.g. WGS-84) and not only on a sphere
- Comprehensive manual (help file) with an introduction to celestial navigation

System Requirements:

1. Windows 95/98/NT/ME/2000/XP Operating System
2. Hard Disk space required is about 10 MB (depending on the operating system and software already installed on your PC).
3. Minimum 256 colours at 800 x 600 resolution

Network Use:

The basic version is a single-user version but can be used through a network with only one person using the program at a time. Contact Seamanship International (info@seamanship.com, telephone +44 (0)141 440 0550, or fax +44 (0)141 440 0418) to add users and enable multi-user network capabilities.



Example of the ASNAv skills

The problem

We must find the noon position of our ship on 3 Nov. 1993 at 1000 GMT (1200 Watch Time) given 8 observations (4 sights of stars at sunrise and 4 sights of the sun during the morning). These observations are real and were taken on 3 November 1993 on board of the LPG tanker 'Eupen'.

Estimated position on 3 Nov. 1993 at 0400 GMT: $32^{\circ}40'.0$ N and $028^{\circ}48'.0$ E
True course = 289° and true speed (speed over the ground) = 17.0 knots
Height of the observer eye = 25 meters
Instrumental error = 2.8 minutes (constant)

Observations:

- ALPHARD at 035551 GMT: $47^{\circ}23'.0$
- SIRIUS at 035826 GMT: $33^{\circ}12'.5$
- ALKAID at 040049 GMT: $33^{\circ}20'.9$
- CAPELLA at 040614 GMT: $47^{\circ}22'.4$
- SUN (lower limb) at 070344 GMT: $27^{\circ}12'.9$
- SUN (lower limb) at 072645 GMT: $30^{\circ}29'.3$
- SUN (lower limb) at 082919 GMT: $37^{\circ}35'.7$
- SUN (lower limb) at 092657 GMT: $41^{\circ}06'.1$

The GPS position at noon was: l_{GPS} $33^{\circ}13'.6$ N and g_{GPS} $026^{\circ}52'.5$ E

The solution by a classic method with exact course and speed

Solution given by ASNAv 0.4 which used a classic method to solve the problem.

DETERMINATION OF POSITION ON 3/11/1993 AT GMT 10.00

[ASNAv 0.4 - OLD ALGORITHM WITH CLASSIC METHOD]

Le	Ge	computed by DR from	L'e	G'e	at GMT	EYE [m]
33.132 N	26.536 E		32.400 N	28.480 E	4.00	25.0

since GMT 1.0000: 289.0° & 17.0'

at GMT 3.5551: obs. 1 of ALPHARD in estim. pos. 32.396 N 28.493 E
 at GMT 3.5826: obs. 2 of SIRIUS in estim. pos. 32.399 N 28.485 E
 at GMT 4.0049: obs. 3 of ALKAID in estim. pos. 32.401 N 28.477 E
 at GMT 4.0614: obs. 4 of CAPELLA in estim. pos. 32.406 N 28.460 E
 at GMT 7.0344: obs. 5 of SUNLOW in estim. pos. 32.569 N 27.497 E
 at GMT 7.2645: obs. 6 of SUNLOW in estim. pos. 32.591 N 27.424 E
 at GMT 8.2919: obs. 7 of SUNLOW in estim. pos. 33.048 N 27.225 E
 at GMT 9.2657: obs. 8 of SUNLOW in estim. pos. 33.102 N 27.042 E

	GMT	Sft	GHA	δ	Hs	i	Ho	Hc	ΔH	Z
ALPHARD	3.5551	0	319.339	8.379 S	47.230	2.80	47.161	47.150	1.1	163.0
SIRIUS	3.5826	0	0.487	16.423 S	33.125	2.80	33.050	33.048	0.2	214.4
ALKAID	4.0049	0	255.490	49.206 N	33.209	2.80	33.134	33.132	0.2	48.9
CAPELLA	4.0614	0	24.553	45.594 N	47.224	2.80	47.155	47.165	-1.0	304.4
SUNLOW	7.0344	0	290.022	15.053 S	27.129	2.80	27.212	27.204	0.8	133.2
SUNLOW	7.2645	0	295.475	15.056 S	30.293	2.80	30.379	30.369	1.0	138.1
SUNLOW	8.2919	0	311.260	15.064 S	37.357	2.80	37.447	37.440	0.6	153.8
SUNLOW	9.2657	0	325.505	15.071 S	41.061	2.80	41.152	41.143	0.9	170.9

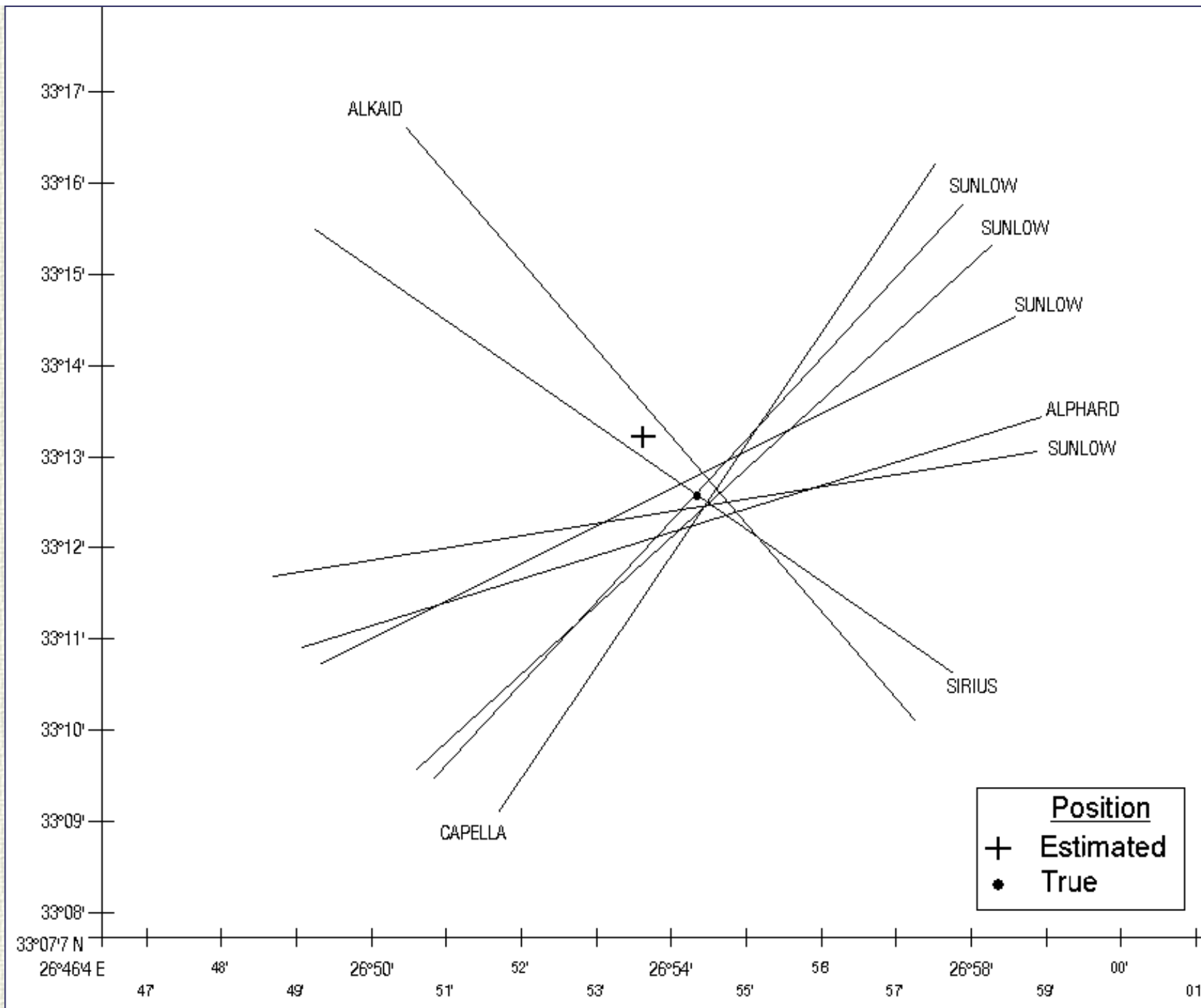

The true astronomic noon position is l 33°12'.6 N and g 026°54'.3 E, which is close to the GPS position (l_{GPS} 33°13'.6 N and g_{GPS} 026°52'.5 E). **The difference is 1.8 nautical miles.**

If we know precisely the course and speed of your ship and if the observations are taken with care, the classic method gives an accurate result. But what's happening if the course and /or speed are underestimated or overestimated?

The solution by a classic method with inaccurate course and speed

Suppose that, due to a stronger current than expected, the true course is overestimated (292° instead of 289°) and the speed underestimated (16' instead of 17'). An estimation error of 3° on the true course and 1 knot on the speed over the ground can occur easily due to the poor knowledge of the current patterns on the high seas (just where the astronomic position is the sole backup of the GPS).

Solution given by ASNAv 0.4 which used a classic method to solve the problem.

DETERMINATION OF POSITION ON 3/11/1993 AT GMT 10.00

[ASNAv 0.4 - OLD ALGORITHM WITH CLASSIC METHOD]

Le	Ge	computed by DR from	L'e	G'e	at GMT	EYE [m]
33.160 N	27.024 E		32.400 N	28.480 E	4.00	25.0

since GMT 1.0000: 292.0° & 16.0'

at GMT 3.5551:	obs. 1 of ALPHARD	in estim. pos.	32.396 N	28.492 E
at GMT 3.5826:	obs. 2 of SIRIUS	in estim. pos.	32.398 N	28.485 E
at GMT 4.0049:	obs. 3 of ALKAID	in estim. pos.	32.401 N	28.478 E
at GMT 4.0614:	obs. 4 of CAPELLA	in estim. pos.	32.406 N	28.462 E
at GMT 7.0344:	obs. 5 of SUNLOW	in estim. pos.	32.584 N	27.542 E
at GMT 7.2645:	obs. 6 of SUNLOW	in estim. pos.	33.007 N	27.475 E
at GMT 8.2919:	obs. 7 of SUNLOW	in estim. pos.	33.069 N	27.291 E
at GMT 9.2657:	obs. 8 of SUNLOW	in estim. pos.	33.127 N	27.121 E

	GMT	Sft	GHA	δ	Hs	i	Ho	Hc	ΔH	Z
ALPHARD	3.5551	0	319.339	8.379 S	47.230	2.80	47.161	47.150	1.1	162.9
SIRIUS	3.5826	0	0.487	16.423 S	33.125	2.80	33.050	33.048	0.2	214.4
ALKAID	4.0049	0	255.490	49.206 N	33.209	2.80	33.134	33.132	0.2	48.9
CAPELLA	4.0614	0	24.553	45.594 N	47.224	2.80	47.155	47.164	-0.9	304.4
SUNLOW	7.0344	0	290.022	15.053 S	27.129	2.80	27.212	27.222	-0.9	133.3
SUNLOW	7.2645	0	295.475	15.056 S	30.293	2.80	30.379	30.385	-0.6	138.2
SUNLOW	8.2919	0	311.260	15.064 S	37.357	2.80	37.447	37.446	0.0	153.9
SUNLOW	9.2657	0	325.505	15.071 S	41.061	2.80	41.152	41.129	2.3	171.1

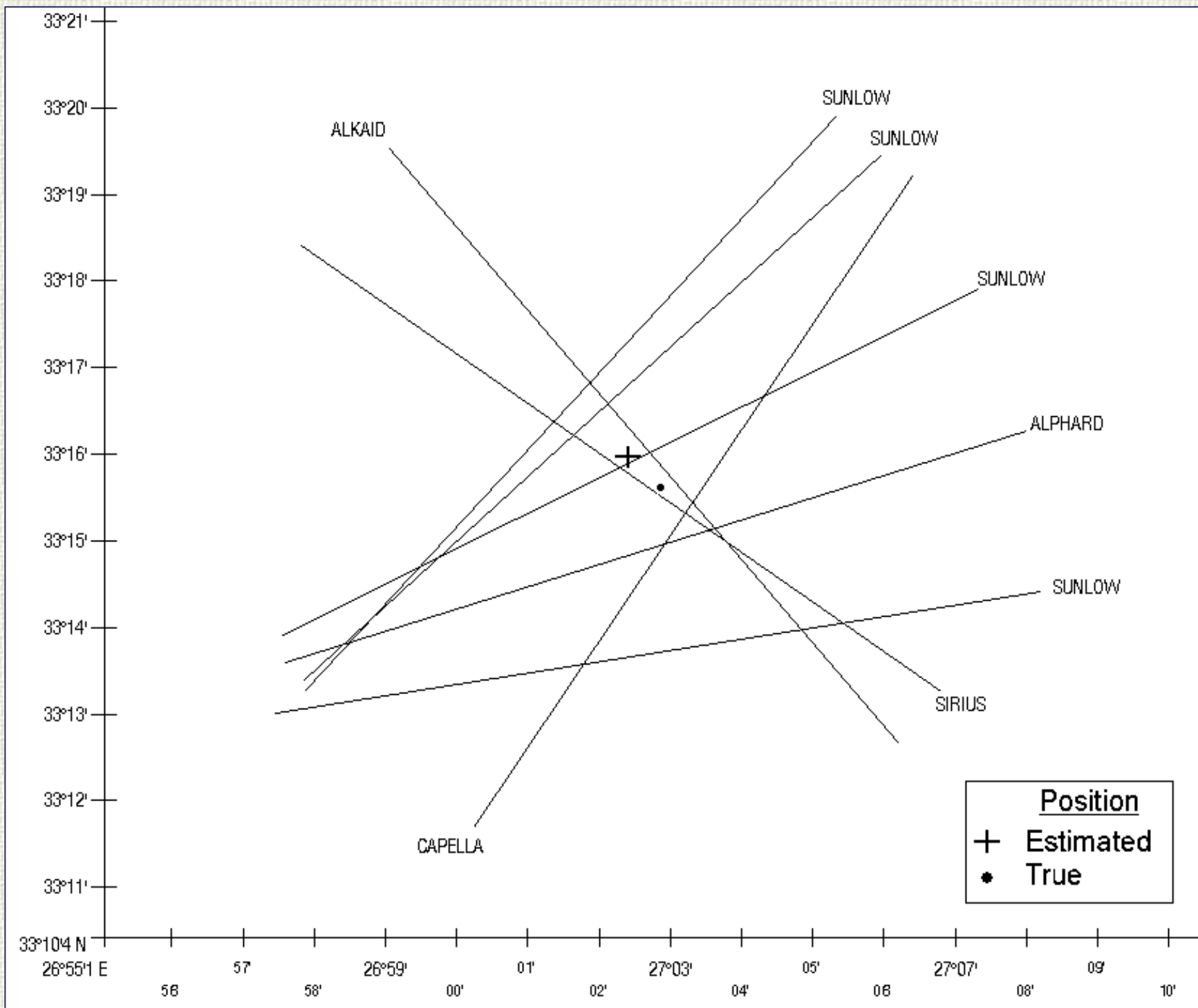

The true astronomic noon position is l 33°15'.6 N and g 027°02'.8 E, which is far from the GPS position (l_{GPS} 33°13'.6 N and g_{GPS} 026°52'.5 E). **The difference is 8.9 nautical miles !**

The cause of the error is the transfer the LOPs along a incorrect course and for a too short distance (underestimated speed).
It's impossible to avoid this error with a classic method.
Now, let's see if ASNAv 1.1 can perform better...

The solution by ASNAv 1.1 with inaccurate course and speed

Same situation which has wrecked the classic method: the true course is overestimated (292° instead of 289°) and the speed underestimated (16' instead of 17').

Astronomic position by ASNAv 1.1

Position:

The most probable position on 3 nov 1993 10:00:00 is Lat 33°12',4 N and Long 026°53',9 E
with an ellipse of 95,0 % probability of NS $\frac{1}{2}$ axe = 0,65 nautical miles and EW $\frac{1}{2}$ axe = 1,67 nautical miles.
The circle of equivalent probability has a radius of 1,36 nautical miles.
The estimated position on 3 nov 1993 10:00:00 was Lat_{est.} 33°16',0 N and Long_{est.} 027°02',2 E.

Observer motion:

The program had enough good observations to use the full routine and to correct the course = 288°,9 and the speed = 17,1 knot(s).

Statistics:

The program found a solution after 3 iterations.

The **weight given to the observations** after statistic analysis is (from not valid 0 % to 100 % certainty):

- ALPHARD 3 nov 1993 03:55:51 = 90,0 %
- SIRIUS 3 nov 1993 03:58:26 = 96,9 %
- ALKAID 3 nov 1993 04:00:49 = 85,6 %
- CAPELLA 3 nov 1993 04:06:14 = 83,9 %
- SUNLOW 3 nov 1993 07:03:44 = 99,8 %
- SUNLOW 3 nov 1993 07:26:45 = 84,4 %
- SUNLOW 3 nov 1993 08:29:19 = 77,9 %

- SUNLOW 3 nov 1993 09:26:57 = 96,3 %

The **standard deviations** for the 4 solutions is:

Lat $33^{\circ}12',4$ N $\pm 0',3$

Long $026^{\circ}53',9$ E $\pm 0',7$

Course $288^{\circ},9 \pm 0^{\circ},2$

Speed $17,1$ knot(s) $\pm 0,1$ knot(s).

Conditions of the observations:

Height of observer eye: 25,0 m \leftrightarrow 82,0 feet.

Air temperature: $10^{\circ}\text{C} \leftrightarrow 50^{\circ}\text{F}$.

Water temperature: $10^{\circ}\text{C} \leftrightarrow 50^{\circ}\text{F}$.

Atmospheric pressure: 1010 mbars (hPa) \leftrightarrow 29,83 inches of Hg.

Details:

Follow the detailed results for every observation computed using a recalculated position for each observation from the initial estimated position given by the user on 3 nov 1993 04:00:00:

Lat_{est.} $32^{\circ}40',0$ N and Long_{est.} $028^{\circ}48',0$ E. Course $288^{\circ},9$ & speed $17,1'$.

The main algorithm of ASNAv does not use these results.

They are only provided for comparison with manual calculations.

1) ALPHARD on 3 nov 1993 03:55:51

Estimated position: Lat₍₁₎ $32^{\circ}39',6$ N and Long₍₁₎ $028^{\circ}49',3$ E

GHA $319^{\circ}33',9$

δ $08^{\circ}37',9$ S

Hs $47^{\circ}23',0$

I $+0^{\circ}02',8$

Ho $47^{\circ}16',1$

Hc $47^{\circ}15',0$

ΔH $+0^{\circ}01',1$

Z $163^{\circ},0$

Δ $+103,6$

2) SIRIUS on 3 nov 1993 03:58:26

Estimated position: Lat ⁽²⁾ 32°39',9 N and Long ⁽²⁾ 028°48',5 E

GHA 000°48',7
δ 16°42',3 S
Hs 33°12',5
I +0°02',8
Ho 33°05',0
Hc 33°04',8
ΔH +0°00',2
Z 214°,4
Δ +102,9

3) ALKAID on 3 nov 1993 04:00:49

Estimated position: Lat ⁽³⁾ 32°40',1 N and Long ⁽³⁾ 028°47',7 E

GHA 255°49',0
δ 49°20',6 N
Hs 33°20',9
I +0°02',8
Ho 33°13',4
Hc 33°13',2
ΔH +0°00',3
Z 048°,9
Δ +102,2

4) CAPELLA on 3 nov 1993 04:06:14

Estimated position: Lat ⁽⁴⁾ 32°40',6 N and Long ⁽⁴⁾ 028°46',0 E

GHA 024°55',3
δ 45°59',4 N
Hs 47°22',4
I +0°02',8
Ho 47°15',5
Hc 47°16',5
ΔH -0°01',0

Z 304°,4
Δ +100,6

5) SUNLOW on 3 nov 1993 07:03:44

Estimated position: Lat ₍₅₎ 32°56',9 N and Long ₍₅₎ 027°49',3 E

GHA 290°02',2
δ 15°05',3 S
Hs 27°12',9
l +0°02',8
Ho 27°21',3
Hc 27°20',1
ΔH +0°01',1
Z 133°,2
Δ +50,1

6) SUNLOW on 3 nov 1993 07:26:45

Estimated position: Lat ₍₆₎ 32°59',1 N and Long ₍₆₎ 027°42',0 E

GHA 295°47',5
δ 15°05',6 S
Hs 30°29',3
l +0°02',8
Ho 30°37',9
Hc 30°36',6
ΔH +0°01',3
Z 138°,1
Δ +43,6

7) SUNLOW on 3 nov 1993 08:29:19

Estimated position: Lat ₍₇₎ 33°04',8 N and Long ₍₇₎ 027°21',9 E

GHA 311°26',0
δ 15°06',4 S
Hs 37°35',7
l +0°02',8

Ho 37°44',7
Hc 37°43',8
 Δ H +0°00',9
Z 153°,8
 Δ +25,8

8) SUNLOW on 3 nov 1993 09:26:57

Estimated position: Lat ₍₈₎ 33°10',1 N and Long ₍₈₎ 027°03',4 E

GHA 325°50',5
 δ 15°07',1 S
Hs 41°06',1
I +0°02',8
Ho 41°15',2
Hc 41°14',3
 Δ H +0°01',0
Z 170°,9
 Δ +9,4

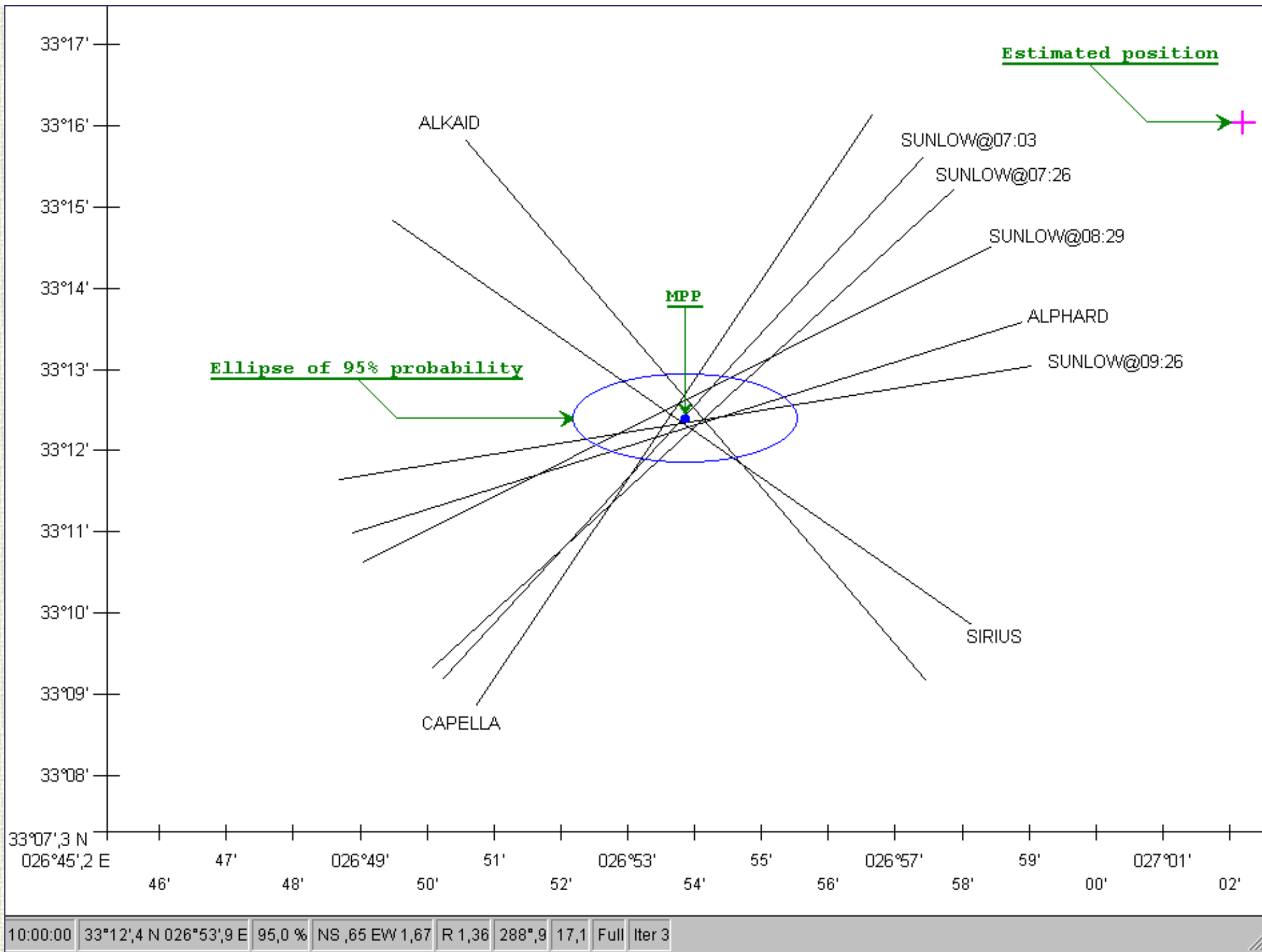

The Most Probable Position (MPP) computed by the program is λ $33^{\circ}12'.4$ N and g $026^{\circ}53'.9$ E, which is very near to the GPS position (λ_{GPS} $33^{\circ}13'.6$ N and g_{GPS} $026^{\circ}52'.5$ E).

The difference is only 1.7 nautical miles. This is less than the classic method with exact course and speed !

The corrected course is 288.9° and the corrected speed is 17.1 knots. Starting with 292° and 16 knots, the program was able to find the exact values with an error of 0.1° and 0.1 knot.

This is one of the reasons why I can say that ASNAv is smarter than the existing astronavigation programs.

[Go back to the manual main page](#)

[Go back to celestial navigation for dummies](#) (an introduction to celestial navigation theory)

[Go back to the ASNAv home page](#)



Utilities : rhumb line, great circle and ETA calculation

On the tab 1 of this dialog box, you find a rhumb line calculation utility using accurate formulas on an ellipsoid.

The difference with programs using traditional methods of calculation on a sphere is about 0.5 %. The default ellipsoid is WGS 1984 but you can change it by double clicking on his (blue) name on the dialog box or by using the "[Options](#)" menu.

Enter 4 data's (green boxes), the program will compute the 2 others (yellow boxes). Any combination is valid.

This makes possible to enter a departure position (latitude, longitude), a course and an arrival latitude OR longitude. You get the corresponding longitude (or latitude) and the distance. It is very useful to **plot precisely rhumb lines extending on several charts**.

Note that all distances in this program (with *one exception*) are in **nautical miles of 1852.0 meters**. Some other programs express the distances in geographical miles. The length of a geographical mile depends on the ellipsoid used for the computations. According to the WGS 1984 model, a geographical mile = 1855.324847 meters. If you are using "Normal Sphere" as reference ellipsoid, ASNAv is assuming that you want the same results than a traditional method. Because the traditional method results are in geographical miles, *this is the only case where the program gives you distances in geographical miles*.

The traditional methods used are:

- *parallel sailing* if the latitude of the point of departure is the same as the latitude of the point of arrival:

- course = 090° or 270°
- distance [geographical miles] = longitude difference . cos (latitude);
- *Mercator sailing* for all the other cases:
 - $\tan(\text{course}) = \text{longitude difference} / \text{meridional parts difference}$
 { Norie's Nautical Tables meridional parts for latitude L: $7915.704468 \cdot \log(\tan(45^\circ + L / 2)) - 23.388749 \cdot \sin(L) - 0.053042 \cdot \sin^3(L)$ }
 - distance [geographical miles] = latitude difference / cos (course).

These traditional methods can lead to strange results:

L1 10°00'.0 N	G1 010°00'.0 W
L2 10°00'.0 N	G2 010°00'.0 E
CRS 090°.0	Dist 1181.77 gmiles

L1 10°00'.1 N	G1 010°00'.0 W
L2 10°00'.0 N	G2 010°00'.0 E
CRS 090°.0	Dist 1189.62 gmiles

We are keeping these results as it (the "Normal Sphere" option is provided to give exactly the same results than the traditional formulas).

With the accurate formulas on an ellipsoid (e.g. WGS-84), we get:

L1 10°00'.0 N	G1 010°00'.0 W
L2 10°00'.0 N	G2 010°00'.0 E
CRS 090°.0	Dist 1184.01 nmiles









L1 10°00'.1 N	G1 010°00'.0 W
L2 10°00'.0 N	G2 010°00'.0 E
CRS 090°.0	Dist 1184.01 nmiles

Use the [TAB] key to go to the next input field.

When you quit an input field, if it contains valid data, then its background becomes green.

Otherwise, the program asks for correction.

Icons with an eraser are provided to clear an input field or all the fields. The arrows icon allows to swap the departure and arrival positions.

Rhumb Line		Great Circle		ETA Calculation	
Latitude Pos. 1 :	<input type="text" value="10°18'4 N"/>		Use an ellipsoid for full accuracy. The result can be more than 0.5 % off a traditional method result.	Use "Normal Sphere" to compare with the traditional method of the meridional parts (Norie's Nautical Tables data).	
Longitude Pos. 1 :	<input type="text" value="037°41'7 E"/>				
	Course :	<input type="text" value="055°0"/>			
	Distance :	<input type="text" value="04507.75"/>		[nautical miles]	
Latitude Pos. 2 :	<input type="text" value="53°29'5 N"/>		Reference ellipsoid You are currently using <input type="text" value="WGS 1984"/> as reference ellipsoid for all the computations.		
Longitude Pos. 2 :	<input type="text" value="113°17'1 E"/>				
	<input type="button" value="Compute"/>	<input type="button" value="End"/>	<input type="button" value="Next tab"/>		

On the tab 2 of this dialog box, you find a great circle calculation utility using accurate formulas on an ellipsoid.

The great circle calculation on a sphere is a special case of the calculation of an arc of geodesic curve on an ellipsoid. This special case is quite interesting because it leads to equations that can be solved analytically: the equations of the spherical trigonometry. ASNAv is using the spherical trigonometry equations for the "Normal Sphere" option. However, if you want the full precision in your calculations, you need to take into account the real shape of the Earth by using the equations of an arc of geodesic curve on an ellipsoid. These equations *cannot* be solved analytically. They must be solved numerically by iterations: starting by an approximate solution (the one given by the spherical trigonometry), the solution is progressively refined till we reach the desired accuracy. The difference with programs using calculation on a sphere is about 0.5 %. The default ellipsoid is WGS 1984 but you can change it by double clicking on his (blue) name on the dialog box or by using the "[Options](#)" menu.

Enter the departure latitude & longitude and the arrival position. Press [Compute] to get:

- the great circle distance;
- the Vertex position and distance (if on the track);
- the departure and arrival course;
- the equivalent rhumb line distance and the saving you can make;
- the period of the geodesic curve (which is not exactly 360° as for a great circle on a sphere).

If you enter also a longitude interval (minimum $0^\circ 10'$), you get some results more:

- the great circle distance as a sum of small rhumb lines distances (you proceed along the great circle following rhumb lines; the accuracy of your navigation depends on the longitude interval you use);
- the intermediate waypoints (position, course, distance to the next waypoint, total distance gone, distance to go to the arrival point).

The great circle is always the shortest in distance but not always the shortest in time. The "routing charts" and the book "Ocean Passages for the World" (both published by the British Admiralty) are essential readings on this subject.



According to averages of merchant ships computed by the British Admiralty and published in The Mariner's Handbook, Admiralty Sailing Direction, NP100, 6th edition, Hydrographic Office, British Admiralty, page 92, for a North Atlantic crossing, the great circle is the shortest in time only during 13% of the year for a East voyage and 2% for a West voyage. A good compromise between the rhumb line and the great circle is the composite sailing track. With this track, you can limit your trip to a certain latitude. ASNAv is able to solve this problem: if you enter a maximum latitude, ASNAv checks if the normal great circle exceeds this latitude. In such a case, a composite sailing track is computed:

- great circle from departure to the maximum latitude;
- rhumb line at the maximum latitude;
- great circle from the maximum latitude to the arrival point.

Use the [TAB] key to go to the next input field. When you quit an input field, if it contains valid data, then its background becomes green. Otherwise, the program asks for correction.

Icons with an eraser are provided to clear an input field or all the fields. You can use the arrow icons to change the maximum latitude and the longitude interval.

Rhumb Line
 Great Circle
 ETA Calculation

Latitude Pos. 1 : 
 Long. interval : 

Longitude Pos. 1 : 

Latitude Pos. 2 : 



Longitude Pos. 2 : 

Max. Latitude : 

GC Dist 1698,3 / 1698,3
 Vertex latitude 56°29',8 N
 Latitude 56°29',8 N
 Longitude 022°33',8 W
 Distance 1179,9 nmiles
 Courses

Waypoints :

Latitude	Longitude	Course	Dist. to next WP	Dist. gone	Dist. to go
51°46',0 N	055°22',0 W	063°,3	00015,3'		01698,3'
51°52',9 N	055°00',0 W	063°,8	00041,3'	00015,3'	01683,0'
52°11',0 N	054°00',0 W	064°,6	00040,7'	00056,6'	01641,8'
52°28',5 N	053°00',0 W	065°,4	00040,2'	00097,3'	01601,0'

 ALL
 

On the tab 3 of this dialog box, you find a simple ETA (Estimated Time of Arrival) calculation routine.

Just enter your departure time (in any zone time), the arrival point zone time and the distance to go in nautical miles (if you already have calculated a rhumb line or great circle distance, this distance is automatically suggested by the program). You can adjust the speeds to compute and the rounding of the results. ASNAv displays the ETAs on a printable grid.

Use the [TAB] key to go to the next input field. When you quit an input field, if it contains valid data, then its background becomes green. Otherwise, the program asks for correction.

Icons with an eraser are provided to clear an input field or all the observations data's. You can use the arrow icons to change the minimum speed, the maximum speed and the speed interval.

Rhumb Line
 Great Circle
 ETA Calculation

Departure time : **14 août 1999 09:00:00**  in GMT +02

Arrival local time in GMT -05

Distance to go : **01771,77** 

Compute with



min. speed : 10,0 



max. speed : 24,0 

interval : 0,50 

Correct ETA to read

exact time
 tenths of hour
 quaters of hour

 Speed	 ETA in GMT	 ETA in LT
14,0	19 août 1999 13:36:00	19 août 1999 08:36:00
14,5	19 août 1999 09:12:00	19 août 1999 04:12:00
15,0	19 août 1999 05:06:00	19 août 1999 00:06:00
15,5	19 août 1999 01:18:00	18 août 1999 20:18:00

 ALL
 

[Go back to the manual main page](#)

[Go back to the ASNAv home page](#)



Azimuth calculation

This dialog box is used to compute the **compass deviation** by means of an **azimuth observation**

(compass error = compass deviation + magnetic variation).

You must enter:

- the body name;
- the time of observation;
- your estimated latitude and longitude; note that the computer will refuse to enter the letter N, S, E or W if not at the last position; this means that when you edit the latitude or the longitude, you cannot delete a digit because this will shift the letter to the left of the last position, which is not allowed; **so, replace a digit by highlighting it or delete the letter first.**

You should enter:

- the gyrocompass bearing;
- the gyrocompass heading;
- the magnetic compass heading;
- the magnetic variation shown on the chart.

You will get the true bearing of the star and (if enough data's) the compass deviation.

Compute the azimuth
✕

Choose a heavenly body : SIRIUS

Enter the time of observation : 11 nov. 1994 04:13:00

Enter your position :

Latitude : 22°35'.0 N
Longitude : 078°10'.0 W

GHA 012°05'.8
LHA 293°55'.8
δ 16°42'.5 S

True bearing	115°.3	Gyro heading	110°.0
- Gyro bearing	113°.5	+ Gyro error	+ 1°.8
Gyro error	+ 1°.8	True heading	111°.8

True heading	111°.8	Compass error	+ 6°.8
- Compass heading	105°.0	- Magnetic variation	005°.0
Compass error	+ 6°.8	Magnetic deviation	+ 11°.8

Compute





End

E
+
 W
-

The "What is up?" icon is able to list all the visible stars at the user position:

What is up ?

Position of the stars on 11 nov. 1994 04:13:00

 Name of the Star	 Azimuth	 Altitude	 Magn.
POLARIS	000°	23°28'	+2.1
MIRFAK	021°	60°08'	+1.9
DUBHE		03°24'	+2.0
CAPELLA	046°	47°42'	+0.2
POLLUX	066°	18°00'	+1.2
ELNATH	072°	48°09'	+1.8
PROCYON	089°	11°46'	+0.5
ALDEBARAN	095°	57°48'	+1.1
BETELGEUSE	098°	36°31'	+0.6
BELLATRIX	103°	42°54'	+1.7
ALNILAM	110°	36°58'	+1.8
SIRIUS	115°	14°32'	-1.6

End

You can sort the table by names (just click the first column heading), by azimuths, by altitudes or by magnitudes (click and drag the column heading to the left column).

[Go back to the manual main page](#)

[Go back to the ASNAv home page](#)



Star Fix Wizard

The Star Fix Wizard will help you to **prepare the stars observations** in order to get a fix (an astronomical position). This will happen in 4 successive steps.

Step 1 : enter the date and the position of the observer

Enter the date of observation, the estimated latitude and longitude of the observer at the time of observation (this position can be improved later with the results of the [step 2](#) of the Wizard). Enter also the height of the observer eye above the water.



Star Fix Wizard - Enter observation data



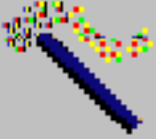

This wizard will help you to select the stars for your observations.



Enter the date of observation :
14 août 1999

Enter your position : latitude **59°30'0 N** 
longitude **003°00'0 W** 

Enter the height of observer eye : **15.0** meters or
049.2 feet



Cancel < Back Next > End

Step 2 : choose Sunrise or Sunset

ASNAv displays the times of sunrise, sunset, upper meridian passage and also the times of the propitious periods to observe the stars.

You must choose if you are interested in a morning or an evening star fix.

Star Fix Wizard - Times		
Time to start morning observations :	14 août 1999 02:59	GMT
Time to end morning observations :	14 août 1999 04:04	GMT
Time of visible sunrise :	14 août 1999 04:23	GMT
Time of theoretical sunrise :	14 août 1999 04:32	GMT
Time of upper meridian passage of the Sun :	14 août 1999 12:16	GMT
Time of theoretical sunset :	14 août 1999 19:59	GMT
Time of visible sunset :	14 août 1999 20:08	GMT
Time to start evening observations :	14 août 1999 20:27	GMT
Time to end evening observations :	14 août 1999 21:31	GMT
Choose the time of observation :	<input checked="" type="radio"/> Sunrise <input type="radio"/> Sunset	
<input type="button" value="Cancel"/> <input type="button" value=" < Back"/> <input type="button" value=" Next >"/> <input type="button" value="End"/>		

Step 3 : select the stars to observe

The program gives the apparent magnitude, the name, the azimuth and the altitude of the stars and planets which are visible at the observer position when it's time to start the morning or evening observations (according to the user preference of the [step 2](#)).

The stars are sorted by decreasing brightness (don't forget the the brightest star has the lowest magnitude number).

ASNAv selects by itself the stars:

- with a magnitude of at least +1.3;
- with an altitude higher than 10° (avoid a too big value of the astronomical refraction);
- with an altitude lower than 70° (because the observation is easier and NOT due to a problem of accuracy; actually, the program don't use the LOPs approximation);
- without a close brightest star (-3.5° to +3.5°);
- without a brightest star exactly opposite (180° - 3.5° to 180° + 3.5°).

You can change the default selection of the program by checking the appropriate boxes.

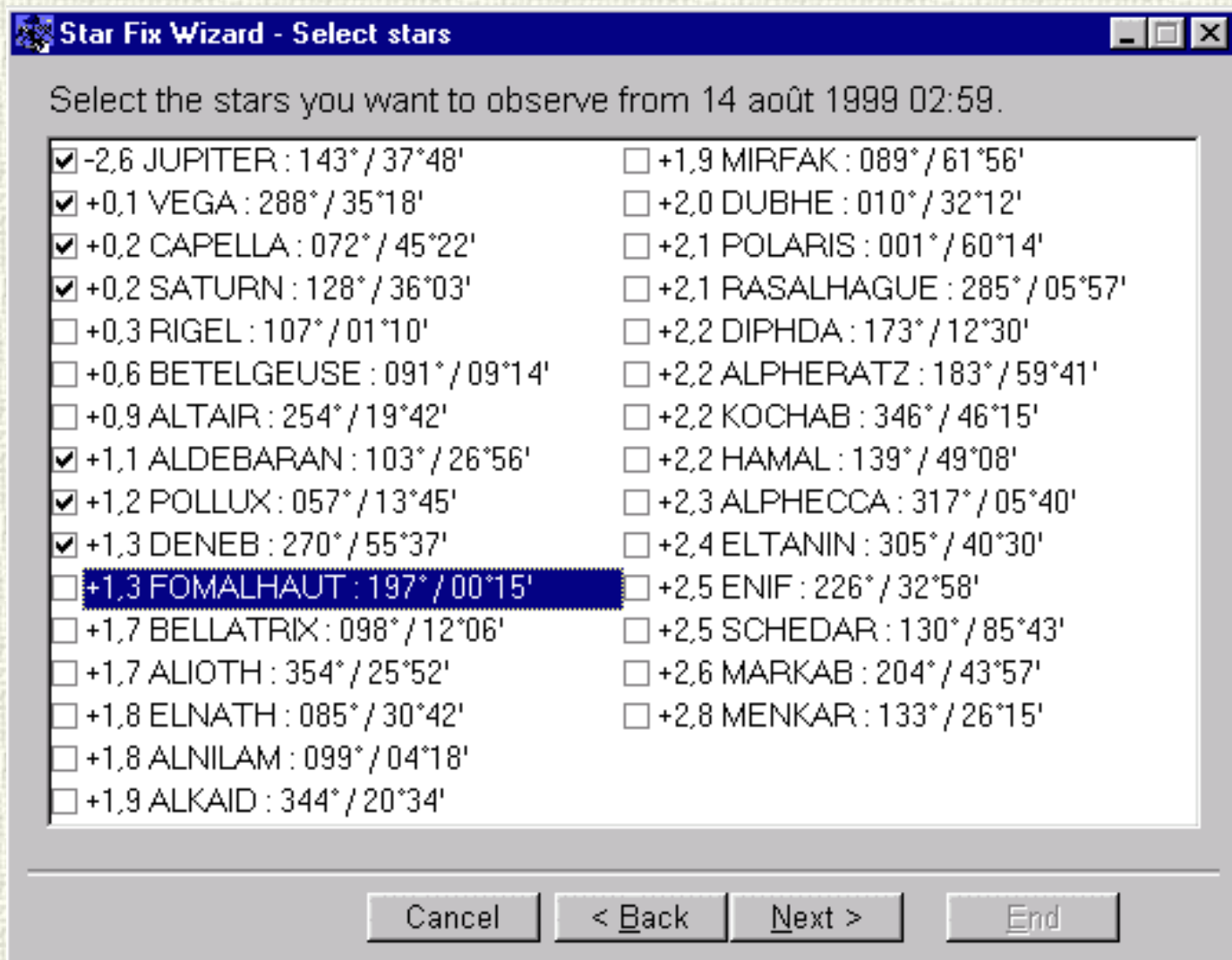

Step 4 : real time display of the stars to observe





ASNAv shows the name, azimuth, altitude and apparent magnitude of the stars selected during the [step 3](#). The time displayed is the time to start the observations. You can change it as you wish. The stars are sorted by increasing azimuth but you can also sort the table by names (just click the first column heading), by altitudes or by magnitudes (click and drag the column heading to the left column).

At any moment, if you click on the clock right icon, you will switch to a real time display according to the GMT system time of the computer (as a matter of fact, the data's are recalculated every 15 seconds). You can change your system time by means of the ["Options"](#) menu.

The Star Fix Wizard can be started before the astronomic position data's entry form and stay open during the observations. Adjust your sextant altitude to the displayed value, take a sight facing the given azimuth and move slightly the sextant micrometer to position the star on the horizon and that's all ... You get your observation.

Star Fix Wizard - Display stars to observe

Position of the selected stars on 14 août 1999 02:59:34

 Name of the Star	 Azimuth	 Altitude	 Magn.
POLLUX	057°	13°45'	+1.2
CAPELLA	072°	45°22'	+0.2
ALDEBARAN	103°	26°56'	+1.1
SATURN	128°	36°03'	+0.2
JUPITER	143°	37°48'	-2.6
DENEK	270°	55°37'	+1.3
VEGA	288°	35°18'	+0.1



Cancel < Back Next > End

[Go back to the manual main page](#)

[Go back to the ASNAv home page](#)

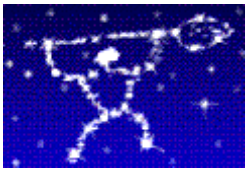

North-South Star Line (Iwikuamo`o, the Backbone)

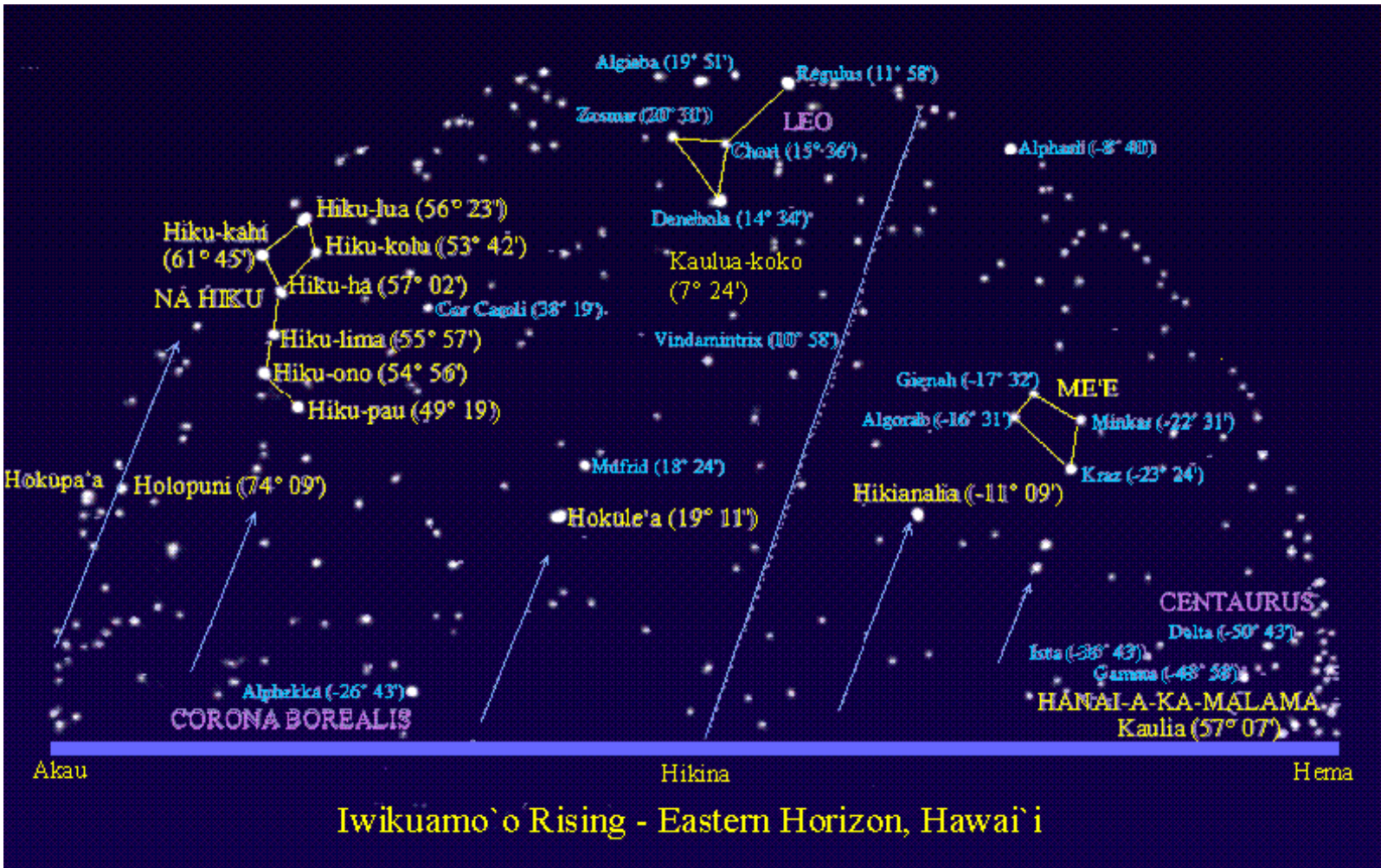

- Akau: 90deg. to 84deg. 23'
- Haka: 84deg. 23' to 73deg. 8'
- Na Leo: 73deg. 8' to 61deg. 53'
- Nalani: 61deg. 53' to 50deg. 38'
- Manu: 50deg. 38' to 39deg. 23'
- Noio: 39deg. 23' to 28deg. 8'
- Aina: 28deg. 8' to 16deg. 53'
- La: 16deg. 53' to 5deg. 38'
- Hikina: 5deg. 38' to -5deg. 38'



[HOME PAGE](#)
[BACK ONE](#)

Sailing Direction Exercises

All sailing directions are kept in relation to the sidereal compass, as are the relative locations of all places of interest, including such numerous seamarks as reefs, shoals, and marine life. To memorize this large body of information the Carolinians have developed various exercises.

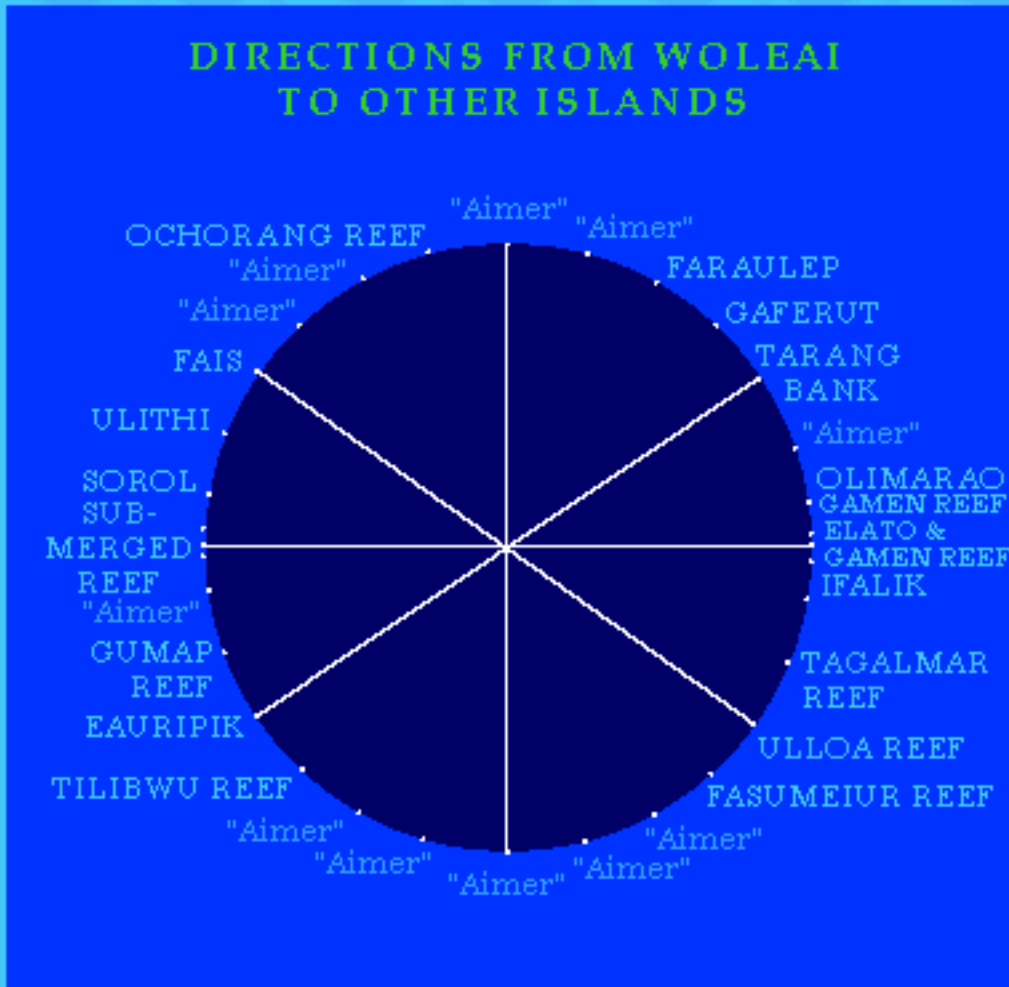

"Island Looking" is the name of the most important exercise. With it, navigators and their pupils endlessly rehearse their knowledge of where islands are located in relation to one another. One takes an island and then goes around the compass naming the places that lie in each direction from that island. Then one takes another island and does the same. As they sit around the boathouse in the evening, older men quiz the younger men and one another. In reciting "Island Looking," a beginner gives the name of the nearest island that lies in a given compass direction from the hub island. As he goes around the compass, if no island lies in a particular direction, he so indicates. Later, the student learns to include reefs and shoals and, finally, living seamarks, thus filling most of the compass directions from each focal island. The sidereal compass here shows the places named on the compass directions as one looks out from Woleai Atoll.

Another exercise, **"Sea Knowing,"** involves learning the names of all the sealanes, called "roads," between the various islands and reefs. To speak of sailing on the "Sea of Beads" is to indicate travel between Woleai and Eauripik on the star course between "Rising of Fishtail" (in Cassiopeia) and "Setting of Two Eyes" (Shaula in Scorpio). Referring only to the names of sealanes, those in the know can tell one another where they have been traveling and leave the untutored in the dark.

The exercise called **"Sea Brothers"** groups sealanes that lie on the same star compass coordinates. Thus on the course from "Rising of Fishtail" to "Setting of Two Eyes" lie the several sealanes that connect the islands of Pissaras and Pulusuk, Pikelot and Satawal, West Fayu and Lamotrek, Gaferut and Woleai, and Woleai and Eauripik. A navigator may forget the sailing directions from Woleai to Eauripik but remember that the Woleai-Eauripik sealane is "brother" to the West Fayu-Lamotrek sealane. His remembering the star coordinates for the latter allows him to retrieve the forgotten coordinates for the former.

"Coral Hole Stirring" imagines a parrot fish hiding in its hole in the reef at a given island. A fisherman probes the hole with a stick to drive the fish out into a dipnet, and it darts off to a hole in the reef at a neighboring island. Again the fisherman tries to catch the fish, and again it darts away to another island, and so on through a series of islands back to the one from which the exercise began. Each such hole has a special name, known only to navigators, that serves as a synonym for the island name. In this exercise the star courses are from hole name to hole name. To learn all of these

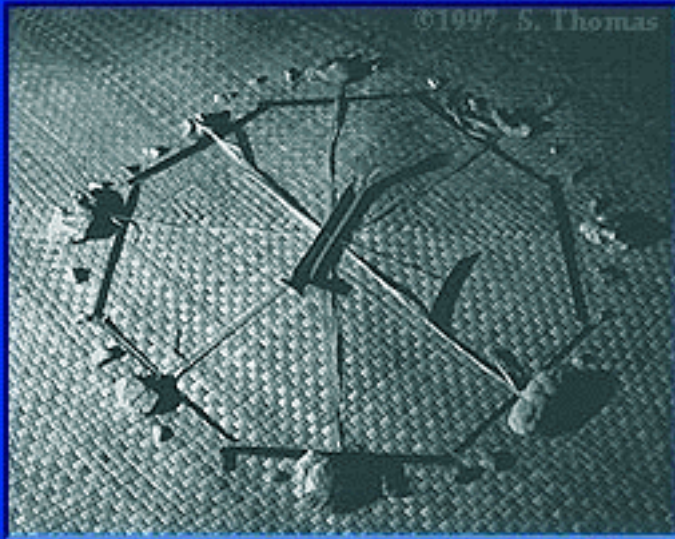

Representation of "star structure"
(sidereal compass) and canoe
for teaching purposes.

star courses is to learn a parallel and redundant set of sailing directions. "Coral Hole Stirring" provides another arena within which to rehearse these directions and, importantly, a way for navigators to discuss voyages within the hearing of others without being understood. Another exercise very similar to this one is called "Sea Bass Groping."

[back](#)

[index](#)

[next](#)

see more online exhibits at
[World Cultures: Ancient and Modern](#)



University of Pennsylvania Museum of Archaeology and Anthropology

©1997



Hawaiian Star Compass

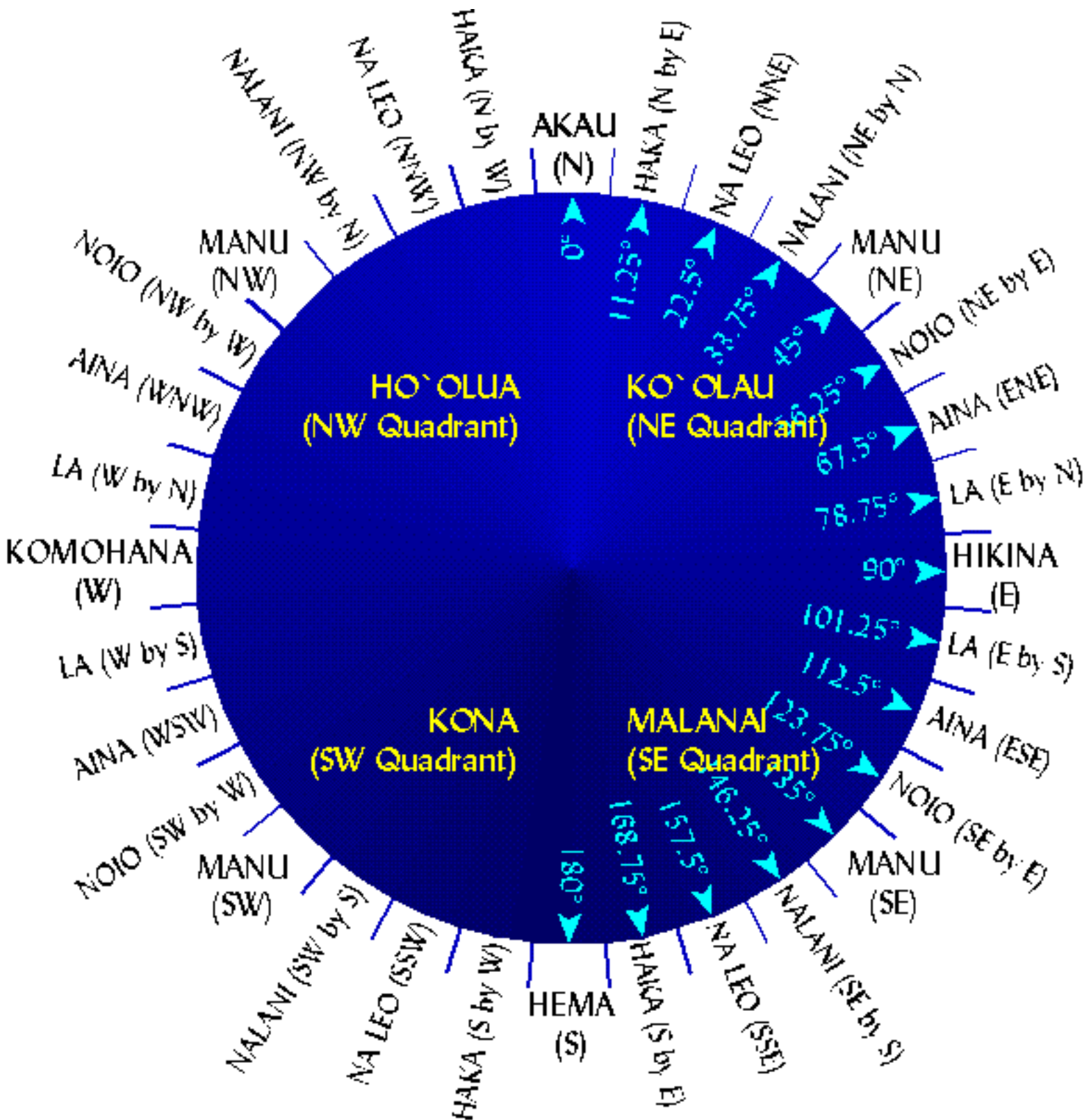

 [HOME PAGE](#)

 [BACK ONE](#)

The Sidereal Compass

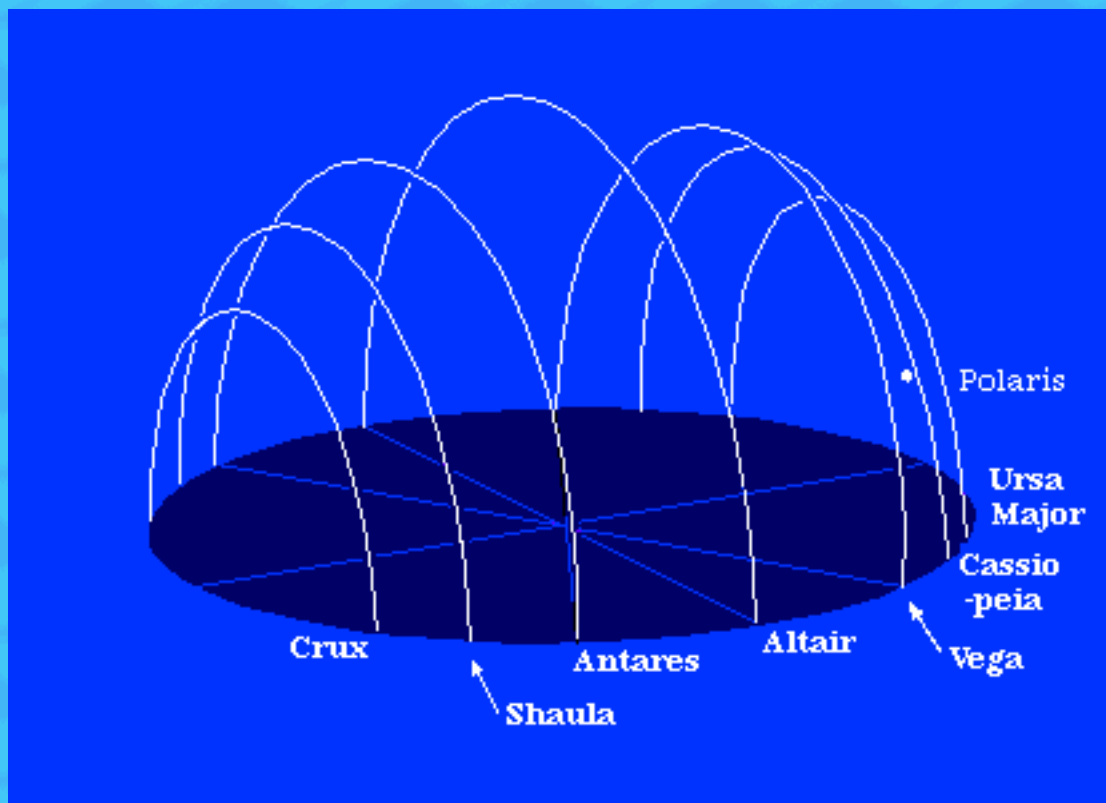

Basic to the entire navigational system is the "star structure," as the navigators call it. Observed near the equator, the stars appear to rotate around the earth on a north-south axis. Some rise and set farther to the north and some farther to the south, and they do so in succession at different times.

The "star structure" divides the great circle of the horizon into **32 points** where the stars (other than Polaris) for which the points are named are observed to rise and set. These 32 points form a sidereal (star) compass that provides the system of reference for organizing all directional information about winds, currents, ocean swells, and the relative positions of islands, shoals, reefs, and other seamarks. The diametrically opposite points of this compass are seen as connecting in straight lines through a central point. A navigator thinks of himself or of any place from which he is determining directions as at this central point. Thus, whatever compass point he faces, there is a reciprocal point at his back.

[back](#)

[index](#)

[next](#)

see more online exhibits at
[World Cultures: Ancient and Modern](#)



University of Pennsylvania Museum of Archaeology and Anthropology

©[1997](#)



Hawaiians as Navigators and Seamen

Samuel Wilder King

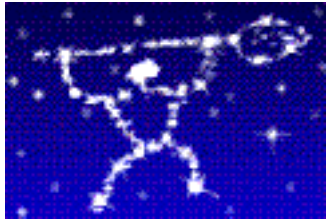

[From the *34th Annual Report of the Hawaiian Historical Society*, 1925, 11-14]

I was reading recently an article that advanced the proposition that the man who first made use of a rude paddle to propel a crude raft was essentially a greater inventor than the many who later developed the rowing boat to its present mechanical excellence. So, in other fields the first germ of an idea was the most important, the big step forward, the later improvements following as a matter of course, inevitable as midday after morning. Our complicated modern civilization gives us immense knowledge, the use of all the stored experience of thousands of years of people of many races; but the big new ideas are still few and far between. It is doubtful if we excel our ancestors in intellect, however much we may be their superiors in knowledge. Judged on their grasp of the fundamentals, the ancient Hawaiians had a splendid foundation in seamanship and navigation. Remote and isolated as they were, and had been for years, what they knew was either part of the scanty heritage brought with them from their ancient home in the west and treasured through all the thousands of miles of eastward migrations, and generations of residence on the fair isles of Polynesia, or was of their own devising. Perhaps some unrecorded Galileo or Lord Kelvin added a mite or two to their original store of knowledge. At any rate we know that the Hawaiians could not benefit from the discoveries and improvements being made in the European world, that the narrow limitations of their islands confined their progress in countless ways, and that the lack of writing made it extremely difficult to standardize their knowledge and keep it clear of error.

When the Haole first came to Hawaii it was a source of wonder to them how the Hawaiians got here. Further acquaintance with the mele (songs) of old voyages increased the wonder. Finally it was borne upon them that the Hawaiians, like their kin throughout Polynesia, were great seamen, with a clear knowledge of the prevailing winds, the moods of the sea, and the signs and portents that foretold the weather. In their canoes, the greatest of which were frail craft compared with the vessels of Cook or Vancouver, they traveled the seas of Hawai'i daringly, braving the currents and tempestuous waves of the island channels, and making far trips beyond the horizon. With mat sails and paddles they accomplished voyages upon which we moderns would hesitate to venture. With neither compass nor chart, sextant nor chronometer, but with mind filled with the ancient lore, handed down through the generations, the lore of wind and sea and sky, they set out, and counted not the mischance of failing to make a landfall.

A priestly astrologer, the kilo hoku would give the more important of the prospective trips a good clearance, or hold the boat for a better day; and mixed with his rites there were always the realities of keen weather observing. Of course the pig must be baked, the 'awa chewed and mixed, the gods propitiated with offerings and prayers, and then the heavens and sea scanned for portents. If the rainbow stood arched in the wrong quarter, if the clouds were flying in scattered fragments, the wind and sea from the wrong direction, the sailing was delayed. But if the indications were fair the astrologer completed the prognosis with an inspired dream, and the voyage was well begun.

The canoe captain, the ho'okele then took command. He knew the different waves with their specific names, equivalent to our own cross sea, following sea, head sea, etc.; and the winds of many kinds, each with its name and peculiar characteristic; and he knew his boat, and how it should be handled under every condition, even to righting it if overturned. To make the desired landfall the ho'okele first located the North Star, in Hawaiian, Hokupa'a, or fixed star, and kept it on the proper bearing; and then selected from the heavens the steering star, the star from among many that would carry him safely to his port. If the little star near Na Hiku (The Seven, or The Dipper) was seen to wink frequently, or if other

signs were present, a storm was approaching, and he steered for a safe haven.

In this manner the Polynesians populated every habitable rock and coral island in an area of ocean greater than a continent. There is no record of those who failed; but of those who achieved a new landfall, and carried the news back to their kinfolk, we have some record, fragmentary it is true, because the Polynesians lacked the art of writing. From what we have we can piece together epic poems of great journeys, sagas of our Pacific Vikings less known perhaps than those of their Norsemen brothers of the sea, but of equal daring and romance, a tribute to the virility and courage of that ancient Polynesian race.

Our modern astrologer is the weather bureau, and our modern ho'okele has many aids in his struggle with the elements, but the principles of taking a vessel from port to port are much the same, based on good seamanship and navigation.

For the long trips, the great voyages to the far off islands of the South Pacific, the navigator knew his astronomy, Ka 'oihana kilokilo, and his geography, kukulu o kahiki, and became he ho'okele-moana, a deep-water sailor. His chart might be the circular base of a gourd, lines burnt in to show the meridian of Hawaii, and the tropics. From Hokupa'a, the North Star, to Newe, the Southern Cross, was the Hawaiian Greenwich; the northern tropic was Kealanui Polohiwa a Kane, the black shining highway of the sun; the southern tropic was Kealanui ka piko o Wakea, the highway to the middle of the earth. The east was Keala'ula a Kane, the red track of the sun; and the west was Kealanui ma'awe'ula a Kanaloa, the wide red track of Kanaloa. In the celestial sphere so bounded moved the stars, na hoku pa'a o ka 'aina, among them the navigational stars (na hoku ho'okele); and the planets, na hoku hele (moving stars). Beyond were strange stars, na hoku o ka lewa. Of the planets the Hawaiians knew five: Mars as Hoku 'ula, the Red Star; Venus as Hoku loa, the Great Star; Jupiter as Ka'awela, the Brilliant One; Mercury as Ukali, the [Sun] Follower; and Saturn as Makulu. Of the stars a great many were listed in the old instructions and mele (songs), many not identified today. Besides the North Star and the Southern Cross, Altair, Vega, Sirius, Orion, the Pleiades, the Dipper, Castor and Pollux, and others were known and studied.

With this stock of knowledge, the Hawaiians used a calendar based on the moon, knew and corrected its error by reference to the stars, named each month, and each night of the month by the characteristics of the moon, and judged the hour closely by the stars at night, or the sun by day. Thus equipped many brave chieftains of the olden times made the great voyage to Tahiti and back. How they provided sufficient food and water, how they survived storms and calms and submerged reefs and lee shores, is but briefly known from the chants that have come down to us. What captains failed and died unsung will never be known. But we do know of many who succeeded, and brought back new chiefs and priests to Hawai'i, new customs and ideas, dances and drums, plants and dresses, and started ferment in Hawai'i that did not end until Kamehameha the Great ruled supreme over the eight islands.

Of Hawai'i specifically, such names as Pa'ao, Kaulu-a-Kalana, Paumakua, and the famous old sea-going family headed by Mo'ikeha and including his foster son La'a, named La'a-maikahiki, the son Kila, and the grandson Kaha'i, have come down to us as great voyagers of a later period, when Hawai'i and the southerly islands revived the old bond, and exchanged ideas and peoples, after several centuries had been allowed to elapse since the original settlers had come north to "Green-backed Hawai'i" as they called it.

The exploits of these Hawaiian Vikings surpass in daring and danger that of the Norsemen. Among those who go down to the sea in ships, the ancient Hawaiians hold a high and honorable place; and the seamen's bent and flavor holds with their children today.

1976: Tahiti	1980: Tahiti	1985-87: Aotearoa (New Zealand)	1992: Rarotonga	1995: Marquesas	1995: West Coast, British Columbia, & Alaska	1999-2000: Rapanui
----------------------------------	----------------------------------	---	-------------------------------------	-------------------------------------	--	--

<u>Voyages</u>	<u>Canoe-Building</u>	<u>Wayfinding</u>	<u>Life on a Canoe</u>	<u>Polynesian Migrations</u>	<u>Proverbs and Traditions</u>
<u>Home</u>	<u>Search</u>	<u>Archives</u>	<u>Past Education Programs & Materials</u>	<u>On-Line Visuals</u>	<u>Bibliographies (Books and Films)</u>

Welcome



E Mau Micronesia at ns.gov.gu

The Voyage Back Home for master Navigator Mau Piailug.

Sailing from Hawaii through Micronesia to Guam

28k Click  server location to view arrival into Agana Guam at 28k.

Main Internet Server	Backup internet server	Govtguam Intranet	UnivGuam Intranet
--------------------------------------	--	-----------------------------------	-----------------------------------

Video provided by Guam's Bureau of Budget and Planning Agency.

56k Click  server location if you have 56k or FASTER bandwidth.

Main Internet Server	Backup internet server	Govtguam Intranet	UnivGuam Intranet
--------------------------------------	--	-----------------------------------	-----------------------------------

Master navigator Mau (nickname Hawksbill turtle) Piailug was welcomed to Guam on April 16, 1999 in ancient ceremonies honoring his student crew of star navigators from the Na Kalai Wa'a Moku O Hawai'i organization. The journey which began in Hawaii on Feb 11 included the Marshall Islands, Kosrae, Pohnpei, Chuuk and his childhood home of Satawal, which is part of Yap. After Guam, the crew will sail to Rota and then to Saipan where Mau Piailug has familial ties. Most notable in his entourage are: Chad Paishon [vessel captain], Shorty Bertelmann [senior student navigator].

The final leg included his arrival on Guam Thursday with a full day of Ancient welcoming ceremonies. Before his landfall, men from the Carolinian island cultural group took turns blowing into a conch shell, producing the low reverberating moan. "In the islands, you cannot blow the conch unless asked by the chief," said Satawal native Samuel Salle Ilesugan who is attending the Univ of Guam. "That means the chief wants to see everybody." " The conch is also used to chase away storms. That's why they have one on the canoe", he said.

Piailug is a traditional 'palu' or fully initiated Yapese navigator who has spent the last two decades teaching sailors in Hawaii about Techniques of Micronesian Navigation. This ancient language of navigation is based on the organization and memorization of a vast quantity of information about the rising and setting positions of the stars with respect to each island, seasonal variations in ocean currents, the properties of ocean swells, clouds, the interpretation of flights of birds for signs of land, and clustering of migratory sea

creatures within fixed geographic ocean locations. In 1970, in violent weather, he led his crew on the nine-hundred-mile round-trip voyage from Satawal to Saipan in his twenty-seven-foot outrigger sailing canoe. Without charts or instruments, he reopen one of his ancestors' trading routes, abandoned for generations. In 1976 he became a hero in Hawaii when he guided the Hokule'a, a replica of an ancient Polynesian voyaging canoe, from Maui to Tahiti without charts or instruments. He had appeared in numerous magazine articles and National Geographic documentary films. In May 2000, he was honored by the Smithsonian Institute in Washington, D.C. which called Mau "one of the most important influences in the resurgence of cultural pride in the Pacific." Jesse H. Marehalau, Federated States of Micronesia Ambassador to the U.S. called Mau "a national hero."

In honor of his contribution, a crew of more than 50 people helped him sail a traditionally designed, Hawaiian 54-foot, double-hulled canoe named Makali'i from Hawaii to the final destination of Guam-Rota-Saipan. For example, on the 3-day leg from Pohnpei to Chuuk his son Sisario Sisaru navigated using star clusters and ocean swells.

The voyage was named "E MAU" to mean "to continue, to preserve; never ending". Open-ocean voyaging without navigational instruments crossing thousands of miles have been guided by the wind, stars, clouds, waves, fish, birds and horizon. Master navigator Mau Piailug has led the past epic Voyages of Hokule'a [from Hawaii to Tahiti in 1976], Hawai'i Loa, and Makali'i between Hawaii, Tahiti, Marquesas and other islands of the Pacific.



LINKS:

- [" Sacred Vessels Navigation "](#)
- ["The Star Cave of Guam. "](#)
- ["Marianas Sea Warriors"](#)
- [The Latte Stone Monoliths.](#)
- [The Ancient People of Guam.](#)
- [The Chamorro Pugua Betelnut](#)
- [Cecilia - Guam's Indigenous Poet](#)
- [Guam Culture Page](#)





Sacred Vessels

Navigating Tradition and Identity in Micronesia

A moving islands production.



Wait 30 secs for the ocean to ripple.

Click table choices below to launch your Real Player to see the Sacred Vessels Film.



CLICK to view the film based on best  server location.

[Main Internet Server](#)

[Backup internet server](#)

[Govtguam Intranet](#)

[UnivGuam Intranet](#)

"Like veins in our bodies, canoes are sacred vessels that carry the life of the people." Thus explains Celestino Emwalu, one of the three navigators featured in *Sacred Vessels*. This documentary examines the survival of traditional canoebuilding and navigation in Polowat (Chuuk State, Federated States of Micronesia) and efforts to revive the seafaring traditions in Guam. It follows the work of brothers Celestino (Tino) and the late Polowat navigator Sosthenis (Soste) Emwalu and Rob Limtiaco, a Chamorro canoe carver from Guam, to trace the character and persistence of traditional seafaring in contemporary Micronesia.

Tino and Soste grew up in the water, building and sailing canoes using traditional ancient ways. Rob grew up in modern Guam, and spent part of his life stateside. On the surface, the islands which they call home are strikingly different, occupying opposite ends of Micronesia's experience of colonialism. Where Guam gives Waikiki a run for its money in the tourist and military industry, Polowat "lacks" power, running water and automobiles. Where Chamorros curse traffic jams in an island that serves as a hub for air traffic flow in the western Pacific and the Far East, the Polowatese lounge in "uts" or canoehouses, walk footpaths to taro patches and routinely tap their "faluva" or "tuba." Where Guam appears hopelessly modern, Polowat appears helplessly primitive.

But through the lens of Soste, Tino and Rob's stories, the indefatigable canoe culture re-emerges to implode these superficial stereotypes of cultural life in contemporary Micronesia, and reveals the persistence of ancient values and traditions and their struggles to navigate the turbulent seas of today.

Like their ancestors before them, Soste, Tino and Rob have re-connected ancient links between Chamorros and Carolinians in their shared efforts to maintain the traditions of the canoe. In the 1980's Rob returned to Guam to study canoebuilding under Tun Segundo Blas, one of the last active Chamorro canoebuilders. Afterwards, Rob and fellow canoebuilder Gary Guerrero would travel to Polowat to learn the arts and science of building bigger, sailing canoes. Both have since maintained close contacts with the Polowatese communities there, and here, in Guam, where they have devoted their lives to promoting the seafaring tradition through carving and through lectures and workshops.

Like most Polowatese of their generation, Tino and Soste travelled to Moen, Chuuk's capital, to attend high school. Upon graduation, Tino went on to college in Hawaii and California while Soste returned to Polowat to continue his studies in canoebuilding and navigation. One of his primary mentors was his adoptive father, Chief Manipy, who was a great navigator. Tino and Soste made a pact: Tino would go and learn about the American ways and Soste would learn the old ways. They would then reunite and teach each other what they had learned. Since the mid 1980s this is exactly what they have done. Until his recent election to public office, Tino served as the Assistant Administrator at the College of Micronesia, Chuuk campus, where he began to develop a Chuuk Studies curriculum with navigation as a centerpiece. Tino and Soste would also travel the region in workshops and conferences to lecture about Polowat's traditions of seafaring made famous by the late anthropologist Tom Gladwin in his book *East is a Big Bird* (Harvard 1970). Tino and Soste were also key leaders in the formation of the Micronesian Seafaring Society, a regional organization of traditional canoebuilders and navigators from Micronesia, created by the initiative of the Guam Council for the Arts and Humanities Agency, with support from the Guam Humanities Council. In the Spring of 1997, Soste taught courses in traditional Carolinian navigation at the University of Guam. Tragically, towards the end of the semester Soste was hospitalized and was diagnosed with advanced cancer of the liver. He died in May but not before rekindling the fires of the seafaring heritage in many of his Chamorro students at the University. Sacred Vessels is dedicated to Sosthenis Emwalu (1952-1997)

The producers of Sacred Vessels are honored to have been given the privilege to work with Tino, Soste and Rob, and with their respective communities. In making Sacred Vessels we wanted to pay homage to those who have paid homage to traditions of the canoe. In paying homage, we also hope that it incites some other person out there to take up the adz, look up at the sky, and carve anew yet another sacred vessel.

To obtain the videotape contact: Pacific Islanders in Communications / 1221 Kapi'olani Blvd. / Suite 6A-4 / Honolulu, Hawai'i 96813 / Tel 808 591-0059 / Fax 808 591-1114 / Email: piccom@aloha.net

LINKS:

- [The Star Cave of Guam!](#)
- [The Sea Warriors of the Marianas.](#)
- [The Latte Stone. Monoliths in Chamoru Prehistory.](#)
- [The People of Guam. The Ancient Ones.](#)

- [The Chamoru love for Betelnut Chewing](#)
- [Cecilia - Guam's Indigenous Poet and Writer.](#)
- [Guam Culture Page](#)

Government

Executive Office

Governor

Lt. Governor

Legislature

U.S. Representative

Taonga



The first of our taonga are publications from the early Dominion Museum Monograph and Dominion Museum Bulletin series. The author, Elsdon Best (1856-1931) was an ethnologist with the Dominion Museum for 20 years and in that time compiled an impressive number of publications on Māori history and lore.

The monographs and bulletins have not been altered in spelling or writing-style in these html versions.

As explained by R.A. Falla (Director of the Dominion Museum from 1947-66) in the foreword to the reprinted monograph no.2

"Although Best's style of writing may seem a little archaic, it was characteristic of his original and independent attitude to the study of ethnology."

Today, these publications can only be found in rare bookshops or the closed collections of public libraries. The Knowledge Basket's intention is to bring New Zealand treasures into the open shelves of the World Wide Web to ensure they continue to enhance our knowledge and understanding of Aotearoa and its

people.

Tihei mauri ora!

(Please be patient - getting these documents will take a little longer than normal)

[DMM 1. Some Aspects of Maori Myth and Religion - By Elsdon Best](#)

[DMM 2. Spiritual and Mental Concepts of the Maori - By Elsdon Best](#)

[DMM 3. Astronomical Knowledge of the Maori - By Elsdon Best](#)

[DMM 4. The Maori Division of Time - By Elsdon Best](#)

[DMM 5. Polynesian Voyagers. The Maori as a Deep-sea Navigator, Explorer, and Colonizer - By Elsdon Best](#)

[DMM 6. The Maori School of Learning - By Elsdon Best](#)

[ABOUT US](#) | [PRODUCTS & SERVICES](#) | [DATABASES](#) |
[TAONGA](#)



Sin at Awarua

Ben Finney

[Photo Below: Matahira Point, Ra'iatea, Tahiti Nui, the site of the marae of Taputapuatea]

During the quiet hours before dawn, twin-hulled voyaging canoes from all around Polynesia began to gather off the coral reef fringing the southwestern end of Ra'iatea, a high, volcanic island a day and a half's sail from Tahiti. Hawai'iloa and Hokule'a had just crossed the equator, sailing all the way from Hawai'i, the northernmost outpost of the dispersed Polynesian nation. The elaborately carved Tahiti Nui, the largest canoe of the fleet, had made its way from neighboring Tahiti. The smallest, lively Takitumu, had come from Rarotonga, a week's sail away to the southwest. The aptly named Te Aurere (the Flying Spray) represented Aotearoa, that massive land located still farther to the southwest beyond the warm seas and trade winds of the tropics. Two more voyaging canoes-Makali'i from Hawai'i and Te Au o Tonga from Rarotonga-were too far out at sea to arrive in time.



The sailors aboard the assembled canoes waited expectantly, maneuvering their vessels in the darkness, taking great care to keep clear of the reef outlined intermittently by white flashes of surf. Gradually the eastern horizon began to brighten, washing out the stars and bringing into focus the mountainous silhouette of Ra'iatea. Then, when the sun rose above the island's green peaks and flooded

over the almost windless sea turning it from black to a deep translucent blue, the crews stirred. Taking up their paddles, they stroked toward the break in the reef known far and wide as Te Avamo'a (literally, the Sacred Pass), into the lagoon that leads directly to Taputapuotea, a great stone temple built just beyond the shore.

Leading the procession was Te Aurere, the canoe from Aotearoa. As its twin hulls passed between the coral heads at the opening of the pass, Te Ao Pehi Kara, a Maori elder, began to chant these somber words:

Tiwha tiwha te Po, Tiwha tiwha te Ao
He whare i mahue kau e He Whare i mahue kau e
Ka whatinga ake te kura o te marama
Ka pahuka mai te moana i nga tai e ngunguru nei
Tenei ko te toka kia tatou
kua hinga ratou kua hinga
kua takoto i te ringa kaha o Aitua

Dark is the night, gloomy the day
The house is left desolate and abandoned
A fragment of the moon is torn away
The sea froths as the waves rush ashore
This is our rock, the rock is left to us
For they have passed on
Laid low by the strong hand of death¹

Those who had been laid low were his tribal ancestors, cruelly murdered centuries earlier at the temple, or marae to use the Tahitian term, of Taputapuotea. But in his next utterance the elder signaled that his message was really about life, not death:

Tihei Mauri Ora!
Let there now be life!

As he continued chanting, Te Ao Pehi Kara developed this theme, declaring that the disastrous breach between his people and those of Ra'iatea, Tahiti, and the other allied islands, and the centuries of desolate solitude that had followed the cessation of voyaging caused by the heinous crime, were now at an end. The tapu² that following the murderous assault had prohibited canoes from Aotearoa and other distant islands from sailing to Ra'iatea had at last been lifted. Long-range voyaging could begin again, bringing the scattered Polynesian peoples together once more:

Tenei te nihinihi tenei te nana
Tenei te wa hikitia nga tapu
o runga i tnei kokoru ki runga
i o tatou matua Tupuna
E tangi ake nei te ngakau
Turuturu o whiti whakamau kia tina
Tina! hui e, taki e.

This is the neap tide and the raging tide,
It is time to remove the tapu
from this bay onto our ancestors.
The heart is moved.
So let it be for all time!
We are united!

Waiting on board a paddling canoe in the Sacred Pass was a bearded Tahitian wearing a long cloak made of bleached bark cloth set off by a short cape of the darkly iridescent feathers of the jungle fowl and a tall headdress topped with more of these plumes. After Te Ao Pehi Kara finished his chant, the costumed Tahitian stood up and declared in his own language that the tapu had been lifted, after which he greeted each successive canoe transiting the pass, intoning words of praise and invoking the gods.

As Te Aurere glided through the pass and entered the broad lagoon a Raiatean orator standing in the shallow water just offshore shouted out in Tahitian: "Come

hither! Come hither o great canoe of Aotearoa!" A woman on shore, similarly bedecked with garlands made from the long shiny leaves of the ti plant (*Cordyline* sp), followed with a chorus of welcoming "come hithers": "Haere mai, haere mai, haere mai." Then a masculine voice from the crowd commanded in Rarotongan that the conches be sounded: "Tangi te pu!" The assembly of trumpeters from Rarotonga then lifted spiraled conch shells to their lips, and blew with all their strength to make a buzzing, throbbing roar that overlaid the welcoming "come hithers" and spread over the crowd massed along the shore to welcome Te Aurere and the other canoes from overseas.

After the crew members of Te Aurere anchored their craft in the lagoon, they transferred to a smaller double canoe fitted with an especially wide platform between the hulls to accommodate passengers. As this canoe approached the narrow beach where the Tahitian dignitaries were assembled, the Maori sailors from Aotearoa were greeted by more "come hithers," blasts from the conch-shell chorus, and then declarations that they had at last returned to Taputapuātea, the marae pu (the central temple) of Polynesia. After the crew waded ashore to be embraced by their hosts, who draped them with garlands made from scented leaves, they formed ranks and acted out a vigorous haka, the ritual challenge by which Maori warriors display with threatening words and defiant gestures their strength and resolve to groups they visit or are visited by.

The sailors were then led by their Raiatean escorts from the landing beach to an adjacent structure, a large, rectangular enclosure bounded by low stone walls. This was Hauviri, a temple of the Tamatoa dynasty, the line of chiefs that had ruled Ra'iatea for centuries. After being welcomed by the Tamatoa descendants, they were taken past the towering investiture stone, a basalt monolith in front of which each new ruler was girdled with the maro 'ura, a broad belt emblazoned with bright red feathers that symbolized chiefly office.

Then to the accompaniment of blasts from conch shells and the beating of drums, the crew was escorted inland over the "Road of a Thousand Flowers" to Taputapuātea itself. This grand temple is an open structure without walls. From a broad platform paved with volcanic stones rises a massive ahu or altar, a narrow

rectangle over 140 feet long and in places twice human height, made from huge slabs of rough coral sandstone set on end and filled with coral rubble.

Against this imposing backdrop, the Maori voyagers mounted the platform and waited as each successive crew came ashore to be welcomed and then escorted to Taputapuātea. As the last of the sailors were taking their places, a spare Tahitian man in his early seventies, dressed in a wraparound pareu, with a short, feathered cloak over his thin shoulders, welcomed the voyagers onto the marae with more "come hithers," pronounced three times in Tahitian, then in Tuamotuan, and finally in Hawaiian. Then he told the assembled crews how "our mother," by which he meant Taputapuātea, was throbbing with maternal joy because "you, the children, the descendants" of those who centuries before had set sail from here to find new lands, had this day returned on your canoes from the "four sides of the dark, dark sea of Hiva," sailing through the Sacred Pass to at last remove the tapu that had isolated Ra'iatea and their own islands for so long.

These events unfolded not hundreds of years ago, but in early in 1995. They were the opening scene of a grand drama enacted primarily for indigenous benefit by chiefs, priests, orators, and dancers as well as by the captains, navigators, and crew members of the canoes, who, along with their supporters, had traveled to Ra'iatea from around Polynesia to celebrate the revival of canoe voyaging that had been developing over the previous two decades.

I was there to document this celebration and the multi-canoe voyage of which it was part, but not at all as a detached observer. I had long been involved in reconstructing and sailing voyaging canoes. (See ["Voyaging into Polynesia's Past."](#)) Then in 1995, thanks to a grant from the Bishop Museum's Native Hawaiian Culture and the Arts Program, I was able to take leave from my teaching duties again so that I could join the assembled canoes at Ra'iatea, witness the ceremonies there, and then sail with the fleet back to Hawai'i.

As I watched the events that day at Taputapuātea, it occurred to me that analyzing them might be of some use in encouraging scholarly thinking about the wave of cultural revival that has recently swept across the Pacific to become more attuned to the thoughts and actions of those actually engaged in the process. In the early 1980s historians, anthropologists, and other scholars began to pay attention to self-conscious efforts of cultural revival among peoples from around the world, focusing particularly on how "traditional" rituals and practices often seemed to have been deliberately created or heavily adapted for political purposes. One of the most influential works published at this time was a collection of essays edited by historians Eric Hobsbawm and Terence Ranger and entitled *The Invention of Tradition* (1983). To them, invented traditions were those that claim or appear to be ancient but had, in comparatively recent times, been "invented, constructed and formally instituted," or had "emerged in a less easily traceable manner." Their examples included the creation in the late nineteenth and early twentieth centuries of royal rituals and pageantry to increase respect for the British monarchy, and the earlier construction by Highland Scots of an identity designed to distinguish themselves from their British overlords, which featured carefully tailored kilts, distinctive clan tartans, and other elements the editors considered to be of "dubious authenticity."

In the Pacific, a flood of journal articles and special issues that began appearing at this time similarly explored how people from the multitudinous cultures of the region were actively engaged in "inventing" or "socially constructing" their cultural values, traditions, and customs.⁴ Although most of these publications were probably not read by those whose efforts and beliefs were being analyzed, a few such works caught the eye of indigenous critics. Prominent among these were Jocelyn Linnekin's (1983) essay on how contemporary Hawaiian nationalists were formulating traditions for political ends, Allan Hanson's (1989) analysis of how contemporary Maori had invented key features of the culture they now present as traditional, and in so doing even borrowed constructs (including accounts of their ancestral migration to Aotearoa!) from late nineteenth and early twentieth century New Zealand scholars, and Roger Keesing's (1989) exploration of how Pacific peoples are "creating pasts, myths of ancestral ways of life" that have little or no

relation to the actual past as "documented historically, recorded ethnographically, and reconstructed archaeologically."

That the subjects of such analyses might take exception to the rhetoric employed is not surprising. In particular, the use of such terms as "invention" and "social construction" can appear condescendingly insulting to those whose beliefs and actions are being scrutinized-particularly when there is a postcolonial power relationship involved. Outraged Maori critics, for example, denounced Hanson's analysis of their traditions as shallow and uninformed (Grainger 1990; Nissen 1990; Noble 1990), while Professor Haunani-Kay Trask (1991), the Native Hawaiian director of the University of Hawai'i's Center for Hawaiian Studies, castigated Keesing, Linnekin, and other foreign academics for setting themselves up as authorities on Pacific Island cultures while ignoring that indigenous people do base their cultural constructs on a deep knowledge and study of traditional ways.

The response made in the name of culture theory that authenticity is a nonissue since in all cultures traditions are invented anyway can be taken as compounding the original insult. As Marshall Sahlins (1993, 4) and James West Turner (1997) have pointed out, arguing that traditions are neither genuine nor spurious but simply socially constructed in effect denies the possibility of expressing a valid cultural identity based on a remembered past. My own experience living and working in Tahiti and Hawai'i over the last four decades has impressed on me how strongly the Tahitians and Hawaiians value links to their past-to the point of going beyond Santayana's dictum about the perils of ignoring history by actively looking backward for inspiration in coping with present and future problems. For example, in an essay on cultural renaissance and identity in French Polynesia, Wilfred Lucas (1989) explained that his fellow Tahitians were "using the past to confront the future," gaining insights and strength from prior accomplishments to help them cope with the Nuclear Age into which they had been thrust. In her treatise on Hawaiian history, Lilikala Kame'eleihiwa (1992, 22), wrote, "It is as if the Hawaiian stands firmly in the present, with his back to the future, and his eyes fixed upon the past, seeking historical answers for present day dilemmas." Such a stance makes sense to those engaged in reconstructing ancient voyaging canoes

and sailing them around the Pacific, or in taking part in the rituals of canoe launching, departure, and arrival. They feel that by reviving elements from their seafaring past they are gaining strength and inspiration for their voyage into the uncharted seas of the future. Yet, as I shall show in the case of the ceremony at Taputapuatea, they are selective about what customs to recall and revive, and what ones to ignore.

Selecting ideas and practices from the past, and then adapting them for present purposes, is hardly limited to today's Pacific. Consider that rediscovery of classical civilization which western Europeans call their Renaissance. Forgotten texts from ancient Greece and Rome were retrieved from old monasteries and Arab libraries to become the basis for learning once more. Long-neglected ruins from antiquity were sketched and studied, and soon facades of new churches began to resemble those of the temples dedicated to banished pagan gods. Yet the architects of Europe's rebirth were not set on recreating all facets of ancient life. They looked for inspiration only to those elements of classical wisdom, design, and practice that were in line with the thinking and needs of this new era, not those they considered anachronistic. To cite a more recent example of such selective inspiration, consider the founding of the Olympic Games late in the nineteenth century. When their founder, Pierre de Coubertin, was seeking a classical model to bring athletes of the world together he chose the pan-Hellenic competitions held periodically at Olympia, not the gladiatorial combat so bloodily celebrated in Rome's Colosseum. Furthermore, he did not seek to impose on the athletes of the reborn Olympic Games the ancient practice of competing in the nude (MacAloon 1981).

Today ethnic groups, nations, and would-be nations from around the world are engaged in selectively recalling their respective cultural heritages, bringing them forward, however altered, into the present. This is as much an age of cultural revival as it is of globalization, particularly in those regions, such as the Pacific Islands, where indigenous peoples are still under foreign rule or have only recently escaped from it to find that the outside world and its influences are still

pressing on them. Reviving declining languages and other cultural elements has become a way to demonstrate cultural identity and worth in relation to both the old colonial structure and increasingly impinging globalizing pressures. From this perspective, it is no accident that the voyaging revival first took hold in Hawai'i, Aotearoa, the Cook Islands, and Tahiti and its neighbors, for their people have suffered greatly from initial contact with the outside world and continue to bear the brunt of foreign impact. They therefore have much to reclaim, and a strong motivation for asserting their identity vis-à-vis their former or actual colonial overlords, and others who have settled in their islands or who now visit them in mass as tourists.

To begin with, continental diseases previously unknown in these islands ravaged their inhabitants, killing them outright and psychologically debilitating the few survivors. For example, by the 1890s the number of Hawaiians had fallen to around 40,000, a catastrophic drop even using conservative estimates of from 250,000 to 400,000 Hawaiians living in 1778 when Captain Cook opened the islands to the outside world-and an even more horrific tragedy if revisionist estimates that there may have been upward of a million Hawaiians are accepted. The survivors of this biological onslaught were then economically overwhelmed by colonizing Americans and Europeans who eventually developed a sugar industry in the islands, after which the Hawaiians were demographically swamped by laborers brought in primarily from Asia to work the plantations. In the end, despite the Hawaiians' valiant efforts to join the world community of nations as the sovereign Kingdom of Hawai'i, foreign businessmen and sugar planters staged a revolution in 1893 with the help of marines landed from an American warship, declared a republic, and five years later convinced the United States to annex the islands. This left the Hawaiians as a largely dispossessed minority in their own islands, which became a territory and then later a state of the United States.

The Maori experienced a similar depopulation and occupation by foreign settlers, in this case predominantly from Britain. Although the Treaty of Waitangi signed by Maori chiefs and British representatives in 1840 supposedly guaranteed most of the land to the Maori, after the wars of the 1860s, the British took over vast tracts of native lands, opening the country for wholesale colonial settlement. This

relegated the Maori to the marginal position of a deprived minority in an overseas territory of a European power that has since evolved into the predominantly white country of New Zealand. Those Tahitians, and their cousins in the neighboring Marquesas, Tuamotu, Gambier, and Austral archipelagoes who survived the biological onslaught of imported diseases, saw their islands taken over piecemeal by France between 1842 and 1888 to form a colony now called French Polynesia. Yet they were not so overwhelmed by foreign settlers and laborers as were the Hawaiians and the Maori, and remained a majority in their own islands, keeping control of much of the land. Nonetheless, being ruled by a proud European power has had its costs, the most recent of which has been the obligation to host France's nuclear-testing program. Even the Cook Islanders, now sovereign in their own islands, have not escaped unscathed from their brief period of colonial rule by and continued dependency on New Zealand.

When the Hokule'a project began in the early 1970s the ways by which Hawaiians had tried to accommodate to the annexation and Americanization of the islands were beginning to unravel. Hawaiians were starting to demand the return of their lands and sovereignty, and were seeking to go back to their cultural roots. Learning to speak Hawaiian, tracing family genealogies, performing ancient dances and songs, and other explorations into the ancestral culture began to attract more and more young men and women. For them the launching of Hokule'a opened up a new window into their past, and with the success of the 1976 voyage to Tahiti and back the canoe emerged as a cultural icon, a rallying symbol of an emergent Hawaiian Renaissance. Hokule'a empowered young Hawaiians to explore the technology and skills by which their islands had been first discovered and settled. By sailing over the long sea routes of legend they could demonstrate how superbly adapted were their ancestral canoes and ways of navigating to the exploration and settlement of their island world, and also prove themselves worthy heirs of a great seafaring tradition. Even those who did not have the opportunity to sail on the canoe could with pride vicariously experience the first voyage to Tahiti, and the other expeditions to the South Pacific that followed.

After completion of the long voyage to Aotearoa and return in 1987, a new canoe, Hawai'iloa, was conceived to further the voyaging revival in Hawai'i. Whereas

Hokule'a had been built mostly with modern materials, the hulls, crossbeams, and other components of Hawai'iloa were to be carved from local trees, lashed together with lines braided from the fibers of coconut husks and other indigenous plants, and powered by sails woven from lauhala, the leaves of the pandanus tree. The new canoe's first mission was to sail over a route never traveled by **Hokule'a** : from Te Fenua 'Enata, the archipelago almost two thousand miles southeast of Hawai'i and known to the outside world as the Marquesas Islands, to the Hawaiian chain. This voyage was planned to commemorate the original discovery of Hawai'i, for on linguistic grounds it is thought that the first Hawaiians came from Te Fenua 'Enata.[5](#)

While Hawai'iloa was still under construction, several other voyaging canoes were being built in the South Pacific, a sure indication that the voyaging revival had by then spread beyond Hawai'i. When in 1992 **Hokule'a** sailed to Rarotonga to take part in a gathering of these new canoes being held there during the Pacific Arts Festival, Nainoa Thompson, **Hokule'a**'s navigator who was in charge of the Hawai'iloa project as well, invited all the new voyaging canoes, including any that might be built in the near future, to join in the commemorative voyage from Te Fenua 'Enata to Hawai'i. One thing led to another, and the initial rendezvous of all the voyaging canoes, and accompanying ceremony, was set for Taputapuātea.

The textual inspiration for celebrating the voyaging revival by gathering all the canoes at Taputapuātea came from a tale told around 1830 to a British missionary by Tu'au, a Raiatean ari'i vahine (female chief) who had learned it from her grandfather, Tai-noa, said to be one of the last Raiatean sages fully conversant with the old learning. It was not printed until almost a century later, when it appeared in English translation in *Ancient Tahiti*, a volume of Tahitian traditions compiled by the missionary's granddaughter, Teuira Henry (1928, 119-128).[5](#) The story begins with the marriage of Poiriri, a "prince" from the distant island of Rotuma located on the far western edge of Polynesia, and Te'ura, a "princess" from Porapora, the island immediately to the northwest of Ra'iatea that is often spelled Borabora. Their union led to the inauguration of the

Fa'atau Aroha (Friendly Alliance) of islands from across Polynesia, centered on the Opoa district of Ra'iātea where Taputapuātea is located.

The islands in this alliance were organized into two sides called Te-ao-uri and Te-ao-tea, terms that Teuira Henry translated as "The-dark-land" and "The-light-land," respectively. In one of the few sections of her account given in Tahitian as well as English, she quoted a song commemorating the formation of the alliance, which begins with these lines:

Na ni'a Te-ao-uri. / Above (east) is dark-land,
na raro te-ao-tea, / Below (west) is light-land,
E to roa te manu e. / All encompassed by birds.

Actually, **Na** ni'a and **na** raro mean "above" and "below" in the sense of "to windward" and "to leeward" of Ra'iātea with respect to the easterly trade winds. Tahiti and the other islands immediately to windward of Ra'iātea belonged to The-dark-land, as did the islands of the Austral group which, although they lie south of Ra'iātea are to windward of that island with respect to the trade winds blowing from the southeast. The-light-land was composed of the islands to the leeward of Ra'iātea, starting with neighboring Taha'a, Porapora and its outliers, continuing on to Rarotonga and the other islands of the Cook group, and then jumping from there all the way to Aotearoa and Rotuma.⁷

According to the text in Ancient Tahiti, for many generations, "priests, scholars and warriors" from the two sides periodically set sail from their respective islands to meet at Taputapuātea and celebrate "great religious observances and international deliberations"-until a murder shattered the alliance. At the last of these reunions ever to be held a quarrel arose between Paoa-tea, a high priest of The-light-land, and a "responsible high chief" of The-dark-land who in his anger slew the priest. When the victim's fellow delegates learned of his murder they in turn struck down the killer. Leaving him for dead (unbeknown to them he was later revived), they took to their canoes to flee back to their islands in the west. But they did not sail directly out to sea through Te Avamo'a (the Sacred Pass) through which they had recently entered. Instead the aggrieved delegates slipped

through the deep waters of Ra'iatea's broad lagoon to Te Avarua (the Double Pass), so called because an islet in the middle divides the channel, and then struck out for the open ocean. "Thus ended the friendly alliance which long had united many kindred islands." The great canoes from the distant islands of The-light-land never again sailed together to Ra'iatea.

Teuira Henry also cited oral traditions from Aotearoa and Rarotonga that corroborated this Raiatean account of the ancient crime and its consequences (1928, 127-128). These had been brought to her attention by S Percy Smith, the New Zealand scholar who founded the Journal of the Polynesian Society and who devoted much of his life to tracing Maori origins. In 1897, while traveling around Polynesia in quest of traditions that might indicate whence the ancestral Maori had set sail, he had visited Henry in Honolulu where she was preparing Ancient Tahiti for publication while teaching at the Kamehameha Schools, an institution founded by the will of the late Princess Bernice Pauahi Bishop. Smith (1898, 47) was particularly excited to learn about the Raiatean tradition of the murder of the high priest of The-light-land and the subsequent flight of his delegation, for in it he saw the key to the meaning of lines of an old Maori song that hitherto had been opaque to him:

Tenei ano nga whakatauki o mua-
Toia e Rongorongo "Aotea,"
ka tere ki te moana.
Ko te hara ki Awarua i whiti mai ai i Hawaiki.

These are the sayings of ancient times-
Twas Rongorongo launched "Aotea,"
when she floated on the sea.
Because of the sin at Awarua they crossed over from Hawaiki.[7](#)

He reasoned that the Hawaiki whence the Aotea canoe "crossed over" the sea must have been Ra'iatea, since that island's ancient name was Havai'i, the Tahitian way of pronouncing Hawaiki. (The /w/ in Maori and the /v/ in Tahitian are equivalent, as are the Maori /k/ and the Tahitian glottal stop /'/.) Although the

Maori tradition refers to multiple victims where only a single victim is featured in the Raiatean and Rarotongan accounts, this equivalence of Hawaiki and Havai'i, plus that of Awarua and Avarua, led Smith to conclude that the "sin" in question must refer to the same murderous assault and flight through the Double Pass as that memorialized in the Raiatean tradition. Teuira Henry noted other obvious links: Aotea, the name of the **Maori** canoe, appears also in Te-ao-tea, the Tahitian name for leeward half of the Friendly Alliance, as well as the place name Aotearoa.

The Rarotongan account of these events appeared in *A Narrative of Missionary Enterprises in the South Seas*, a best-seller among pious British and American readers of the nineteenth century written by the missionary John Williams (1838). In his book Williams recounted how after the people of Tahiti, Ra'iatea, and neighboring islands had been converted, he and his fellow missionaries of the London Missionary Society sought to search out still more islands to gain additional converts. He was particularly anxious to find Rarotonga, an important island that Raiateans told him lay well to the southwest, but he failed to locate it in his first attempt. On his second try, thanks to precise sailing directions provided by the inhabitants of Atiu, a tiny island a day and a half's sail to windward of Rarotonga, Williams finally located the sought-for island, and he and his Raiatean assistants went ashore. When the Rarotongans learned that the group were from Ra'iatea, they demanded to know why their ancestors had killed the Rarotongan high priest Paoa-tea, using the same name given in the Raiatean account. They also wanted to know what had happened to the great drum their priests had transported to Taputapuatea to present to the god 'Oro, calling it Tangimoana (Sounding-at-sea), which but for a sound change is identical to ta'imoana, the name employed in the Raiatean account for all the big drums carried aboard the canoes making the pilgrimage to Taputapuatea. To Williams, this tale and other indications of previous relations between Raiateans and Rarotongans meant that "it is certain that at some former period more frequent communication must have existed between the islanders" (1838, 56, 104).

The idea that a formal tapu on voyaging had been laid down came neither from the Raiatean text, nor from the Maori and Rarotongan versions, but from an inspired orator who spoke at Taputapuātea when Hokule'a made its first visit there in 1976, right after reaching Tahiti. Well before then, Hokule'a designer Herb Kane and I had pored over Ancient Tahiti and other writings that stressed the centrality of Ra'iatea in Eastern Polynesia, and we concluded that Hokule'a had to make a pilgrimage to Taputapuātea to make the voyage more culturally meaningful. We knew that with the coming of Christianity early in the nineteenth century the temple had been abandoned as a formal religious center, and that although some rites may well have continued to be secretly practiced there for decades after conversion Taputapuātea no longer played a formal role in Raiatean life. When I had visited Ra'iatea in 1962 the stone structure lay deserted and crumbling, surrounded by rows of carefully laid out coconut palms. The once-sacred precincts around the marae had been turned into a plantation for the production of copra, the dried meat of the coconut sent to industrial countries for the manufacture of soap, margarine, and other products for the world market. Therefore, in the back of our minds was the hope that sailing Hokule'a there might serve to awaken Raiatean interest in their ancient center.

The scene that greeted the canoe as it anchored offshore of the marae in 1976 made it clear that our coming had generated more than a little excitement. On hearing of the impending visit, the Raiateans had cleared the temple's broad stone pavement, cleaned the grounds around it, and repaired some of the worst damages to the long altar. Then, when the canoe finally arrived from Tahiti, the great mass of Raiateans assembled there to greet their cousins from across the equator demonstrated that Hokule'a had indeed roused Taputapuātea from a long slumber. As the Hawaiians came ashore, they were welcomed with chants and then escorted to the temple proper where they were honored by songs, prayers, and speeches. Their Raiatean hosts expressed admiration for the long canoe voyage and their joy at the coming of their kin from Hawai'i, whose ancestors, they said, had long ago sailed from Ra'iatea, which, they emphasized, had then been called Havai'i, their way of pronouncing Hawai'i (Finney 1979, 278-286).

Then an unscheduled orator, a short, balding man, began to spin a tale that offered

a somewhat different perspective on the cessation of voyaging to and from Taputapuātea from that recorded a century and a third earlier. The orator—who we learned later was known by everyone as Parau Rahi (Big Talk)—began by telling how hearing that Hokule'a was coming made him recall a prophesy told to him by his elders when he was a small boy. Long ago, they said, a migratory canoe called Hotu te Niu had set sail from Ra'iātea carrying a selection of the most skilled people from Ra'iātea and neighboring islands—the best sailors, farmers, healers, and the like, as well as fertile women skilled in domestic crafts, who had all been chosen for what they could contribute toward sailing the canoe to an uninhabited island and implanting a colony there. No family groups departed together, just these specially selected individuals. Parents who had to give up a son or daughter, as well as the husbands or wives of those who had been chosen, had been forced to accept that they would never see their loved ones again. As the years passed with no word of the success or failure of this expedition, a great sadness descended over Ra'iātea and the neighboring islands, leading the aggrieved parents, spouses, children, and other kin to declare a tapu on any further overseas voyaging that would be lifted only when a canoe bearing the descendants of those long-lost migrants returned to Taputapuātea.

Parau Rahi then told the enthralled crowd that when he had heard that a canoe from Hawai'i had reached Tahiti and that it was scheduled to sail to Taputapuātea, he thought that the canoe must be carrying the descendants of those who had left so long ago—particularly given the identity of the name Hawai'i with Havai'i, the ancient name of Ra'iātea. This, he told the crowd, filled him with joy, for he knew that the coming of Hokule'a would therefore lift the voyaging tapu. Then, after a pause, Parau Rahi's expression changed totally. Glowering at the crew, he shouted out: "But, you have ruined everything! You made a terrible mistake! You did not sail in through the Sacred Pass!"

We had not at all been focused on exactly recreating the way canoes had once sailed to the marae. Instead of closely studying Teuira Henry's text and consulting Raiatean elders knowledgeable about how visiting canoes should approach Taputapuātea, we had followed the directives of Tahitian port authorities to sail directly to Ra'iātea's official port of entry, Uturoa, and register there before

proceeding to the temple. This meant that instead of entering the lagoon through the ritually prescribed pass of Te Avamo'a, **Hokule'a** had sailed through Te Avarua, the pass that leads directly to the port of entry and through which the survivors of that fateful attack of centuries ago had fled. From Uturoa the canoe reached Taputapuatea through the lagoon instead of sailing back out to sea and then reentering through the Sacred Pass, which we gladly would have done had we known the importance of so doing. By the time we realized our error, it was of course too late to do anything about it. Even sailing **Hokule'a** smartly out the Sacred Pass on leaving that evening for Tahiti did not set things right for Parau Rahi and those who had been impressed by his speech.

Despite Parau Rahi's criticism, and the outrage expressed by some local Protestant pastors about the "pagan" ceremonies conducted at Taputapuatea, **Hokule'a**'s coming stimulated Raiatean leaders to think more seriously than they ever had before about the importance of Taputapuatea in their history and what role the marae might play in contemporary life. A key person in this rethinking has been Pierre Sham Koua, a school administrator and sometimes vice-mayor of Uturoa, Ra'iatea's port town and administrative center, whose name reflects his Polynesian, Chinese, and European ancestry. Before the voyaging revival started, Pierre had long been interested in Taputapuatea and its ancient role as a politico-religious center, but he did not fully realize how important voyaging was to that history until **Hokule'a** first came there and he served as the orator welcoming the Hawaiians ashore. Soon thereafter he discovered that the voyaging connection could directly serve the cause of historic preservation. By citing the cultural importance of the site as manifest by our pilgrimage made all the way from Hawai'i, Pierre was able to shelve a government plan to bulldoze Taputapuatea and turn the grounds into a soccer field.

Pierre's vision of the role Taputapuatea could play in contemporary Ra'iatea evolved further as he again welcomed **Hokule'a** back to the marae in 1985 at the beginning of its two-year-long voyage to Aotearoa and return, and then once more in 1992, when it called there on the way to the Pacific Arts Festival in Rarotonga.

He came to envisage Taputapuātea as more than just an ancient temple where "folkloric" ceremonies could occasionally be reenacted. He wanted it to become a vital cultural center that would bring together people from all the islands and archipelagoes of Polynesia for cultural exchanges, workshops, and scholarly meetings. As a former Catholic seminarian, as well as an ardent student of ancient Tahitian culture, Pierre was also well aware of the value symbolic action could have in promoting that vision. Hence, when he heard that in 1995 all the voyaging canoes would rendezvous at Tahiti before sailing together for the Marquesas and Hawai'i, he worked hard to get them to call at Taputapuātea before heading north, and to take part in a grand ceremony at the marae to mark the opening of this new era of Polynesian voyaging.

At the same time, the indigenously controlled government of French Polynesia, which exercises autonomy over internal affairs, saw an opportunity to finance the preservation of Taputapuātea as a cultural monument that would serve as both a pan-Polynesian meeting center and a tourist attraction to help lure overseas visitors. Funds were therefore allocated to repair Taputapuātea and associated structures, and to clear the surrounding grounds in order to open the complex to public view. For this inaugural event, the government's Ministry of Culture and the Museum of Tahiti and the Islands also produced a handsome brochure, entitled *A Fano Ra*, a poetic expression that may be translated as "Sail On." It featured a chart showing the canoes and the routes each would take to Ra'iātea, and then collectively on to Te Fenua 'Enata and to Hawai'i.

In developing the scenario for the ceremonies to welcome the canoes to Taputapuātea, the organizers drew from both the tradition of how the murder of a priestly delegate from The-light-land led to the breakup of the Friendly Alliance and the cessation of voyaging, and Parau Rahi's idea that a formal tapu on voyaging needed to be lifted. (They conveniently forgot that Hokule'a had supposedly already lifted the tapu by sailing to Taputapuātea through the Sacred Pass, first in 1985 at the request of the followers of Parau Rahi, who had died earlier that year, and then again in 1992 while on the way to Rarotonga.) Despite differences in detail between the Raiatean, Rarotongan, and Maori accounts of the assault on the delegates from the The-light-land, they followed Teuira Henry in

concluding that these must refer to one and the same event. The organizers then took S Percy Smith's reasoning that Maori voyagers had been the victims a step farther by proposing that if the tribal descendants of those who had suffered would forgive the assault on their ancestors then the tapu on voyaging that had been laid down following this ancient crime could at last be lifted. That would be an ideal way, they thought, to symbolize that the revival of Polynesian voyaging was fully launched, as well as to reestablish Taputapuātea as the sacred center of a reconstituted Friendly Alliance of Polynesian peoples.

So at a planning meeting held in Rarotonga the organizers approached Heke Nukumaingaiwi Puhipa, the builder and captain of Te Aurere canoe who is more commonly known by his English name of Hector Busby. Hector, a large rough-hewn man in his early sixties who had retired from his bridge-building business in order to construct Te Aurere, told them that he had never heard anything about the "sin at Awarua," but nonetheless agreed to try and find a knowledgeable Maori elder who could compose and then chant the words needed to lift the voyaging tapu as Te Aurere was entering the pass. Hector's search led him to Te Ao Pehi Kara, a scholarly, retired headmaster who was also a leader in Aotearoa's Kohanga Reo movement to reverse the decline of the Maori language by means of special preschools taught entirely in Maori. Yes, the elder told Hector, he had heard a tradition about the murderous assault at Hawaiki on crew members of the Aotea canoe, and would be honored to do his part in lifting the tapu.

Once the crews were assembled before the long altar of Taputapuātea, each was joined by delegates-government officials, elders, orators, dancers, chanters, and others-representing the islands whence the canoes originated. In addition, a cultural association composed of men and women from the 'Ua Pou, one of the ten islands of Te Fenua 'Enata, joined the other delegations on the marae, as did a small group of men representing Rapa Nui, the lone island two thousand miles to the southeast of Tahiti known to the outside world as Easter Island. Neither group had a voyaging canoe, but both wanted their respective islands to be part of this celebration. The 'Ua Pou delegates had come to express

their solidarity with the voyaging revival and to request that when the canoes sailed to Te Fenua 'Enata they pay a call on 'Ua Pou as well as the main island of Nukuhiva. The Rapa Nui delegates, who were actually from an immigrant community long established on Tahiti, had come as would-be voyagers. They had learned about this happening far too late to even think about building a voyaging canoe, but did manage to hastily put together an outrigger canoe covered with reeds to recall the reed vessels their ancestors had been forced to make after centuries of human occupation had stripped Rapa Nui of trees. After shipping their canoe to Ra'iatea the night before the ceremony, they relaunched it and made their way to Taputapuātea just in time to earn a place on the marae.

Each island delegation was given the opportunity to express their sentiments and thoughts, which they enthusiastically did through traditional chants, songs of the *himene* type (an astonishing combination of missionary-introduced hymn singing with the indigenous chanting style), and dances, as well as by speeches and in one jarring instance a Christian prayer asking Jehovah not to be angry about this assembly on an ancient center of the old religion. Central to these presentations were recollections in prose, dance, and chant of the exploits of the voyaging heroes and migratory canoes of the respective islands. Many speakers also stressed how the history of their own islands was bound up with that of Taputapuātea. For example, Larry Kimura, a professor of the Hawaiian language at the University of Hawai'i's Hilo branch, spoke for the Hawai'i delegation in his native tongue, stating how his people were tied to Taputapuātea through ancient kinship and because their ancestral blood had flowed on the marae.

No laila makou e huli hele nei ho'i i ke alahula i alahula ho'i ia makou i o ko makou mau kupuna i o kikilo a hiki maila ho'i makou i o 'oukou i keia 'aina, ko makou 'aina ia 'o ko 'oukou 'aina ho'i ia. 'O ko makou 'aina kupuna e moe maila ho'i ko makou 'iewe i kanu 'ia i loko o ka honua o keia mau paemokupuni. I hiki maila ho'i makou no ka ho'ōia 'ana ho'i i ko makou koko 'o ko 'oukou koko he ho'okahi no ia. 'Aohe no mea e ho'okanalua ai. Ua 'ike 'ia ho'i ua kahe ho'i ke koko o kupuna o kakou i ola ho'i ke kapu o kia marae nei a kakou e ku nei.

This is our return in search of the well-traveled pathways that have become so familiar to us because of our ancestors of antiquity. And now we have arrived before you at this place which is ours as well as yours. These are our ancestral lands where our afterbirth remains still, where it has been buried in the earth of these island archipelagoes. We have come to affirm our blood ties with yours as one. There can be no question about this. It is recognized that the blood of our ancestors has flowed to bring life and sanctity to this marae we now stand on.[8](#)

With each island delegation delivering speeches, chants, and songs, the ceremony went on and on. By late morning the participants were suffering visibly from standing in the blazing sun on the unsheltered stone platform, which in turn caused a breakdown of the strict protocol that called for their isolation from the crowd surrounding the marae (photo 2). Green drinking coconuts, plastic bottles of water, and cans of soft drinks were being passed from the crowd onto the marae to provide fluid for the thirsty, heat-struck participants.

Except for these minor infractions, the presentations proceeded as planned until toward noon, when Gaston Flosse, the part-European president of French Polynesia, stepped onto the marae to join the Tahitian delegation. Early that morning when Pierre Sham Koua and I drove to Taputapuataea we had been met at the entrance to the grounds by earnest young Tahitians wearing headbands and draped in green ti leaves. They were members of the youth brigade of the pro-independence political party, Tavini Huira'atira (Servant of the People). They politely but insistently passed out their own brochure bearing a message in Tahitian, English, and French addressed to all their "cousins in the Pacific" and denouncing the collaboration of local politicians in continued French rule, and in particular France's nuclear-bomb-testing program in the nearby Tuamotu Islands. After that they stayed in the background-until President Flosse joined the Tahitian delegation on the marae.

Then members of the youth brigade gathered at the inland end of the platform unfurled long banners condemning Flosse for selling the motherland to the French and their bombs. This display caused a stir among the crowd of spectators, but the canoe crews and delegates on the marae did not overtly react-not even the Cook

Islanders, the closest neighbors downwind of the testing sites at the Tuamotu atolls of Moruroa and Fangataufa located well to the southeast of Ra'iatea. So strongly did the Cook Islanders feel about the tests that later that year when French President Jacques Chirac broke the post-Cold War testing moratorium and announced a new series of nuclear explosions, they sent one of their canoes, Te Au o Tonga, to the testing area to protest the resumption of the deadly explosions there. Yet on this sacred occasion the Cook Islanders, and the other canoe crews and delegates on the marae, were totally focused on completing this ritual confirmation of the opening of a new era of voyaging. Flosse himself, an experienced politician who as a strong supporter of France's right to use Moruroa for testing their deadly weapons was the main target of the demonstration, also paid no heed to the commotion and calmly went ahead with his speech.

With the additional backdrop of protesting banners, the ceremony continued without further incident to the concluding rituals, all meant to seal the reestablishment of the Friendly Alliance of voyaging nations: the drinking of kava by selected crew members of each canoe, the placing on the marae of a heavy stone from each of the represented islands, and the bundling together of lengths of sennit line from each canoe to assure a safe voyage on to Te Fenua 'Enata and Hawai'i.

Protests against nuclear testing. Plastic water bottles as well as bright red cans of Coca-Cola on the sacred marae. Dozens of professional and amateur photographers and also several film teams clustered around the platform and fighting for clear shots. Electronically amplified chants and speeches, and even the utterance of a Christian prayer. However impressive the ceremonial process that unfolded that morning may have been, it was obviously not a slavish reconstruction of the way, as portrayed in the text from Ancient Tahiti, delegates from the islands entered the Sacred Pass and then were welcomed ashore.

Among other things, there were no human sacrifices. Taputapuatea was dedicated to the war god 'Oro who demanded human offerings. Indeed, Teuira Henry

translated the name of the marae as "sacrifices" (taputapu) "from abroad" (atea) (1928, 123). According to the text, at the gatherings of the Friendly Alliance these "sacrifices from abroad" were delivered through the Sacred Pass by the canoes coming from islands belonging to the alliance (Henry 1928, 123-126). The narrative of that delivery starts out with a wide-angle view of "the long canoes in the wind" (te va'a roa o te mata'i) heading for the Sacred Pass, streaming behind them long pennants colored dark or light depending on which half of the alliance they represented:

Upon approaching the sacred passage of Te-ava-moa, just at daybreak, the canoes united in procession, and out from the horizon, as if by magic, they came in double file, each representing a separate kingdom. To the north were those of Te-ao-tea, to the south those of Te-ao-uri, approaching side by side, the measured strokes of the paddles harmonizing with the sound of the drum and occasional blasts of the trumpet.

Then, the focus shifts to a close-up of the canoes and the gruesome cargo carried on their decks:

Across the bows connecting each double canoe was a floor, covering the chambers containing idols, drums, trumpet shells, and other treasures for the gods and people of Raiatea; and upon the floor were placed in a row sacrifices from abroad, which consisted of human victims brought for that purpose and just slain, and great fishes newly caught from fishing grounds of neighboring islands. There were placed upon the floor, parallel with the canoe, alternately a man and a cavalli fish, a man and a shark, a man and a turtle, and finally a man closed in the line.

Once "this terribly earnest procession" reached shore, the voyagers were greeted by the chiefs, priests, and other dignitaries of the place. Then they silently set to work to suspend the sacrificial victims in the trees, stringing them up with long ropes run through their lifeless skulls. Still more bodies were then employed as

rollers over which to draw the canoes onto the land. Though well aware of this ancient protocol, the organizers of this gathering of reconstructed voyaging canoes obviously had no intention of recreating such a grisly spectacle. Instead, they focused on the idea of symbolically renewing interisland ties by ceremonially lifting the voyaging tapu that they believed had been imposed when the Friendly Alliance broke up after the assault on delegates from The-light-land. The organizers and the visiting canoe crews and delegates had gathered at Taputapuātea to celebrate their rediscovery of voyaging, not to recreate past practices in their entirety. To do so, they drew on historical precedents, but selectively, choosing what they wanted in order to commemorate their revival of ancestral technology and skills.

This is not to say that the preparations for, as well as execution of, this event necessarily went smoothly. Indeed the whole process of reviving voyaging has been rich with controversy over such issues as which canoe design best represents an ancient vessel and what ceremonial protocols to follow at the launchings of the reconstructed canoes. In this problematic area of indigenous cultural authority and authenticity, consider the comments of Hōkūle'a designer Herb Kane about a controversy among Hawaiian cultural authorities over the 'awa drinking ceremonies that have come to be a regular feature of canoe launchings and departures.

An article in the August 1993 issue of *Ka Wai Ola O Oha*, the monthly newspaper of the quasi-governmental Office of Hawaiian Affairs, juxtaposed the views of Parley Kanaka'ole and Sam Ka'ai, both of whom were then well known around Hawai'i for presiding over ceremonies in which the soporific infusion of the pounded root of the 'awa plant (known elsewhere in the Pacific as kava, 'ava, yagona, etc) is ladled out, formally presented to participants, and then solemnly drunk, and those of their critic, Kamaki Kanāhele, a trustee of the Office of Hawaiian Affairs (Clark 1993). Kanāhele asserted that there was no such thing as a formal 'awa ceremony in traditional Hawaiian culture, and that the principals in today's ceremonies appeared almost to be making up their ceremonies as they went along. In response, both Kanaka'ole and Ka'ai affirmed that they had not made up their ceremonies on the spot, and that they in fact were following

distinctive procedures for the ritual consumption of 'awa that they had learned from their elders on their respective home islands of Hawai'i and Maui.

In a subsequent issue of the newspaper, Herb Kane (1993) strongly supported the thesis that before the missionary era Hawaiians did have formal 'awa ceremonies, and argued for the legitimacy of the particular practices followed by both Kanaka'ole and Ka'ai. But he did admit that knowledge of the specific chants and other details of the pre-missionary ceremonies have been lost with the virtual disappearance of 'awa drinking among Hawaiians, and that contemporary Hawaiian 'awa ceremonies have been heavily influenced by practices from Western Polynesia, where the drink has continued to be consumed without any hiatus caused by missionary or other foreign pressures. Kane traced this Western Polynesian influence to an 'awa ceremony over which he presided that took place at the launching of Hokule'a in 1975:

This ceremony was offered to us as a gift from a hanai [adopted] member of the royal family of Tonga, including the use of the largest tanoa (kanoa, or bowl) in existence, and there was no pretense about it being Hawaiian. We felt honored by the offer. To decline would have appeared ungracious. Moreover the idea appealed to the cultural purpose of Hokule'a as an instrument that might help bring all Polynesians closer together-an active symbol of a shared ancestry.

That subsequent 'awa ceremonies celebrated by Hawaiians might combine remembered Hawaiian practices with those of their cousins from Western Polynesia did not bother Kane:

We may also be experiencing the dawn of a new (or simply rediscovered) "Pan Polynesian" cultural development as a result of the increasing frequency of cultural exchanges among all Polynesians. When meetings occur between Hawaiians, Tahitians, Maori, or Western Polynesians, much enjoyment is derived from exploring the astonishing similarities within the basics of their respective languages, customs and traditions. From such similarities, bridges of

communication and bonds of friendship are being created; out of these will grow cultural traditions that will be understood by all Polynesians. The Hawaiian 'awa ceremony as interpreted by Ka'ai and Kanaka'ole, because they express the fundamentals universal to the Polynesian concept of good manners, may be counted among these traditions.

One of my longtime Tahitian friends who specializes in oral traditions at the Museum of Tahiti and the Islands avoided the Taputapuātea ceremony, even though she conducted some of the research for it. Instead, she stayed at her family home on adjacent Taha'a, where she helped to organize a low-key, community-oriented reception for the canoes when they called there a few days later. Like a number of other thoughtful students of Tahitian culture, she is disturbed by the practice of staging for tourists "folkloric" reenactments of supposedly ancient ceremonies—such as the elaborately costumed and choreographed ceremonies of chiefly investiture held annually at Tahiti's Arahurahu marae. She would probably agree with Greg Denning's comment about these and other similar ceremonies that such "re-enactments tend to hallucinate a past as merely the present in funny dress" (1992, 4-5, 203-205). The gathering at Taputapuātea might be similarly dismissed as so much folkloric play acting, but for a fundamental difference between it and such tourism-oriented events as the Arahurahu ceremonies. Those who had sailed to Taputapuātea from the "four sides of the dark, dark sea of Hiva," were performing for themselves, and were profoundly affected by their pilgrimage.

Compare, for example, the experience of the crew of the Maori canoe Te Aurere with that of a famous Maori scholar who had visited the marae in 1929, the year after Teuira Henry's *Ancient Tahiti* had been published. The scholar in question, Te Rangi Hiroa, was a physician who had already won fame for anthropological research among his own people of Aotearoa as well as those of the Cook Islands and Samoa, and who later was to be appointed Director of Hawai'i's Bishop Museum, Professor of Anthropology at Yale University, and then knighted, using his European name, as Sir Peter Buck.

For years this distinguished scholar had cherished the wish to make a pilgrimage

to Taputapuātea. From his tribal traditions he knew that some of his ancestors had come from Ra'iātea, and he felt that much of Maori theology had emanated from the island's famous temple. In 1929 he had his chance. While he was conducting fieldwork on the atoll of Tongareva in the Northern Cooks, a passing British warship bound for Ra'iātea offered him passage. After landing at the port town of Uturoa, with great expectations he took a small boat through the lagoon to Opoa, the region where the temple is located. When, however, he at last saw Taputapuātea, Te Rangi Hiroa was utterly devastated by the deserted marae, and brusquely left after a cursory inspection. Later he explained his disappointment:

I had made my pilgrimage to Taputapu-atea, but the dead could not speak to me. It was sad to the verge of tears. I felt a profound regret, a regret for-I knew not what. Was it for the beating of the temple drums or the shouting of the populace as the king was raised on high? Was it for the human sacrifices of olden times? It was for none of these individually but for something at the back of them all, some living spirit and divine courage that existed in ancient times of which Taputapu-atea was a mute symbol. It was something that we Polynesians have lost and cannot find, something that we yearn for and cannot recreate. The background in which that spirit was engendered has changed beyond recovery. The bleak wind of oblivion had swept over Opoa. Foreign weeds grew over the untended courtyard, and stones had fallen from the sacred altar of Taputapu-atea. The gods had long ago departed. (Buck 1938, 81-82)

Sixty-six years later the crew of Te Aurere experienced Taputapuātea in an utterly different way. Instead of the desolate, crumbling marae that had so disappointed their distinguished kinsman, they found a restored temple alive with expectant people. Sailing through the Sacred Pass to remove the voyaging tapu, seeing the huge crowd waiting on shore, and then stepping on land and going through the long series of greetings and rituals to confirm the marae as a new center for pan-Polynesian gatherings totally uplifted these contemporary representatives of The-light-land of old.

Hector Busby, Te Aurere's skipper, was particularly affected by this transcendental experience. When first asked to play a role in lifting the tapu, he had been somewhat hesitant because he had never heard about the "sin at Awarua." But when he found that his friend Te Ao Pehi Kara knew a tribal tradition about this event and would compose a chant of reconciliation, Hector became excited about the task. He told me right after the ceremonies that when Te Aurere entered the pass and Te Ao Pehi Kara began chanting he fell into a trance-like state and personally felt the pain of the assault on his ancestors that day long ago. Then, when the chanting ceased and the tapu was declared to have been lifted, Hector came to, feeling exhilarated at having left the ancient tragedy behind to sail into a new age.

[I WISH TO THANK the Native Hawaiian Culture and Arts Program of the Bernice Pauahi Bishop Museum for their support in enabling me to document the 1995 voyage, Pierre Sham Koua for his hospitality on Ra'iatea and the many insights he has given me, as well as Te Ao Pehi Kara, Papa Matarau (Ivanhoe a Teanotulaitau), Larry Kimura, and countless other participants who helped me better understand what was happening that day at Taputapuatea. In refining my analysis, most helpful were the comments of Geoff White, David Hanlon, Vilsoni Hereniko, and the anonymous reviewers of an earlier draft of this paper.]

[For more on the voyaging kapu at Taputapuatea, see Herb Kawanui Kane's "[The Seekers](#)". Other Writings of Ben Finney on Line: "Voyaging into Polynesia's Past" in *From Sea to Space* (Palmerston North: Massey University, 1992. 5-65): Part 1--[The Founding of the Polynesian Voyaging Society](#); Part 2--[Hawai'i to Tahiti and Return: 1976](#); Part 3--[Hawai'i to Tahiti and Return: 1980](#); Part 4--[Voyage of Rediscovery: 1985-87](#). Also, "[Voyaging and Isolation in Rapa Nui Prehistory](#)".

1976: Tahiti	1980: Tahiti	1985-87: Aotearoa (New Zealand)	1992: Rarotonga	1995: Marquesas	1995: West Coast, British Columbia, & Alaska	1999-2000: Rapanui
Voyages	Canoe- Building	Wayfinding	Life on a Canoe	Polynesian Migrations	Proverbs and Traditions	
Home	Search	Archives	Educational Programs and Materials	On-Line Visuals	Bibliographies (Books and Films)	

[Sin at Awarua / References](#)

Notes

1. Te Ao Pehi Kara graciously provided me with both his Maori text, and his free English translation, of which only portions are quoted here.
2. Along with marae (temple), tapu was introduced into late eighteenth century English through publication in the journals of Captain Cook, and they both can be found today in the Oxford English Dictionary and some other large dictionaries. According to the OED entry, tapu first appeared in print as "taboo" in the 1785 edition of Captain James Cook's journal of his third voyage into the Pacific. Although Cook's spelling is still used in English, tapu, the phonetically more accurate spelling, has long been employed in writing most Polynesian languages, including Tahitian and Tongan (from which Cook took the term), and is an alternate spelling in the OED. (Hawaiians spell the term kapu, reflecting their use of the /k/ sound instead of the /t/.) Although Cook wrote "morai," the phonetically more accurate marae is now employed in writing Tahitian as well as in the OED.
3. Keesing and Tonkinson 1982, Linnekin 1983, and Handler and Linnekin 1984

were early leaders, followed by, among many others, Babadzan 1988; Chapman and Dupon 1989; Stevenson 1990, 1992; Linnekin 1991; Friedman 1992; Jolly 1992; Jolly and Thomas 1992; Sissons 1993; Norton 1993; White and Lindstrom 1993; Tobin 1994; Feinberg and Zimmer-Tamakoshi 1995; Lindstrom and White 1995; Turner 1997. In an essay on the synergism generated by our dual experimental and cultural approach to voyaging, I used the term "re-invention of Polynesian voyaging," but in the sense that because direct continuity with ancient voyagers had been broken we had been forced to employ information from oral traditions, early historical accounts, and the surviving navigational system of the Caroline Islands of Micronesia to literally "re-invent" Polynesian voyaging (Finney 1991).

4. Te Fenua 'Enata is often translated into English as "The Land of Men." However, since 'Enata is a gender-neutral term, the name can be more accurately, if inelegantly, translated as "The Land of Human Beings" (Le Cléac'h 1997, 27-28), but with the understanding that the 'enata (compare Maori tangata, Tahitian ta'ata, Hawaiian kanaka) are indigenous to the archipelago.

5. The missionary John Orsmond arrived at Mo'orea in 1817, soon after most of the Tahitians had converted, nominally at least, to Christianity. It is said that he proved so adept at Tahitian, which he had begun learning from Tahitian shipmates on the long voyage out from England, and had developed such good rapport with Tahitian sages, that King Pomare directed him to interview and record these keepers of oral tradition (Driessen 1982, 5).

6. As roa generally means "long," Henry initially translated Aotearoa as the "Long-light-land." Yet noting that since roa can also mean "distant," she also suggested that Aotearoa might have the meaning of "Distant-light-land," so called to distinguish it from the other islands nearer to Ra'iatea (Henry 1928, 123). However, pointing out that ao can also mean "day," Maori linguist Bruce Biggs translated Aotearoa as "Long Daylight," explaining that the first voyagers to reach this temperate land called it by that name because they were struck by how much longer the summer days were there in comparison with those of their tropical homeland (1990, 7).

7. Teuira Henry (1928, 128) suggested that the second line rendered into Tahitian would be Tohia e roro'o Aotea (Launched for prayer chanting was Aotea), and that this might have been its original meaning.

8. This is the central section of the text and translation that Larry Kimura kindly made available to me.



Why Did the Portuguese Invent the Science of Sailing?

Venturing out on the open ocean of the South Atlantic sailing at first with the currents and winds out to the Azores, Portuguese sailors soon reached the limits of traditional methods of navigation

The North Star



Without any traditional star maps such as these on the left, sailors turned first to the stars they did know and could rely on, the Pole Star and constellations around it.

The North Star is not always in the same place. It moves (very slowly) in a small circle around the pole.

Constellations

The major constellations of the zodiac were extremely important to time-keeping. Knowing the constellation visible in the sky as the sun rose was a secure way of keeping track of days and months when on board ship and the usual clues to the passage of seasons were invisible.

Precession of the Ecliptic Earth Facts



[Back](#) **Why Was Traditional Navigation *Impossible* in the South Atlantic?**



Traditional Navigation required EITHER regular winds and currents OR an easy-to-follow continental shelf. The South Atlantic had neither.

1. No Winds or Currents to follow

The [South Atlantic](#) had neither trade winds nor predictable set of currents that could be followed southward. Instead currents and winds flowed contrary to the southward direction navigators wanted to sail. Folk traditions of nautical star charts or traditional sailors' knowledge were also absent.

2. No Continental Shelf to follow

Africa's [narrow continental ledge](#) provided no alternative for sailors attempting to sail southward in the face of countervailing winds and currents.

[Africa's narrow continental ledge](#) | [South China Sea's Coastal Shelf](#) | [Ocean Currents](#) | [Atlantic Ocean Winds](#) | [Home page](#)

January 16, 1998

KEYWORDS: CONSTELLATIONS, PRECESSION, SIDEREAL ZODIAC, TROPICAL ZODIAC

Debbie Writes:

"I found on-line a scientist that stated the charts that were devised in ancient times are invalid today, but they are still used. He says that the Earth shifts on its axis, and that makes the constellations go into the Zodiac at the wrong dates. Like March 23 should be Aries, but in his mind the Sun is in Pisces. Can you explain what, if any adjustments for all of this have been made over time? This is the only thing negative that I ever hear concerning the accuracy of astrology, and I would like to understand what's going on."

Kevin Answers:

Debbie,

Thank you for an excellent question. This question, in fact, is so fundamental to the understanding of astrology and is the source of so many misunderstandings and misconceptions, that I've also included this response as part of the FAQs (frequently asked questions) part of this web site.

Answering this question, however, is going to require some astronomy as well as some astrology, and the clarification of some terms.

Let's start with the definitions; your terminology in your question was a bit confused, and I know that you're not alone in this.

DEFINITIONS AND GLOSSARY OF TERMS

Celestial Sphere. The ancient understanding of the universe was quite different than our modern understanding of it. First of all, the ancients believed that the Earth was the center of the universe, and that everything revolved around the Earth. They also believed that the Earth was surrounded by a vast black sphere that contained all of the stars, called the **Celestial Sphere**. Even though this is obviously not the way things really are, projecting an imaginary **Celestial Sphere** onto the night sky makes it possible for astrologers and astronomers to measure, track and calculate the relative positions of the stars and planets as they appear from the Earth.

Geo-Centric. Geo-Centric literally means "the Earth in the Center" and this is the approach that is used by most astrologers, and also by astronomers when measuring and observing the stars and planets. On a practical level, it simply means that the sky is being observed from the Earth, and that measurements are based on spherical geometry and the use of the **Celestial Sphere**.

Great Circle. A Great Circle is any circle that divides a sphere (or in particular the **Celestial Sphere**) into two equal halves. The equator is a Great Circle, dividing the sphere of the Earth into two halves. All lines of Longitude are also Great Circles (connecting the North and South poles). Lines of Latitude (except for the equator), however, are not Great Circles.

Fixed Stars. When the ancients observed the night sky, they noticed that some of the stars seemed to move or wander from night to night. These, of course, were the planets. The way that they were able to determine that the planets moved, however, was because they noticed that the rest of the stars in the sky stayed in the same positions night after night. These are the **fixed stars**, and they are used as reference points in order to measure the relative positions and movement of the planets.

Constellations. Constellations are groups of fixed stars, that have become associated with a figure, and often with a myth. The Big Dipper, the Little Dipper, and Orion are probably the best-known and most easily recognized constellations in the night sky (at least in North America). Different constellations are visible at different times from different locations on the Earth. There are literally hundreds of constellations. Among these are the constellations of Aries, Taurus, Gemini, Cancer, Leo, Virgo, Libra, Scorpio, Sagittarius, Capricorn, Aquarius, and Pisces. (As we will discover soon, these constellations are not the same as the Signs of the Zodiac that share these names.)

Ecliptic. The Ecliptic is the **Great Circle** that describes the apparent path of the Sun around the Earth (but which is really the orbit of the Earth around the Sun. The Ecliptic extends approximately 8-9° of arc above and below (North and South of) the actual path of the Earth/Sun. The other planets in the solar system are always visible within this band of sky. The longitudinal (East-West) position of celestial bodies (i.e. planets, asteroids, etc.) is measured along the ecliptic.

Signs. The Signs are units of measurement each equal to 30 degrees of arc along the **ecliptic**.

Zodiac. The Zodiac refers to the different names for the Signs dividing the **ecliptic**. The Signs of the Zodiac are named after twelve of the Constellations that intersect the ecliptic.

Vernal Point. The point measured along the ecliptic which represents the apparent position of the Sun at the moment of the Vernal (Spring) Equinox. At the moment of the Spring Equinox, the Sun is directly overhead at mid-day along the Tropic of Cancer.

THE PRECESSION OF THE EQUINOXES

When you mentioned that the scientist said that "the Earth shifts on its axis and that makes the constellations go into the Zodiac at the wrong dates", what is being described is the precession of the equinoxes. Just to clarify, though, the constellations don't move - remember, they are made up of fixed stars. The Sun is what appears to enter the different Signs of the Zodiac. As to the part about the dates and the Zodiac, we'll get to that shortly.

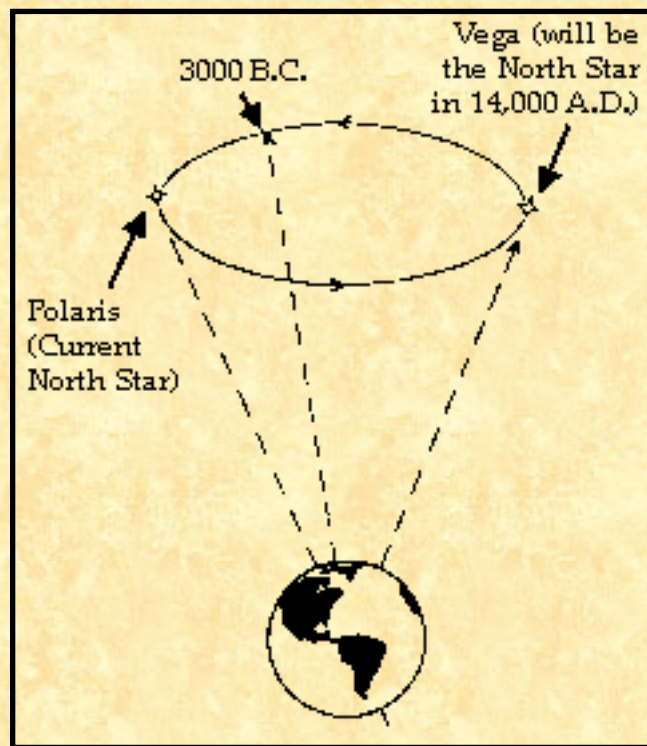

The Earth doesn't so much "shift" on its axis as it "wobbles". The Earth's axis is tilted at an angle of approximately 23.5° to the plane of the ecliptic. This tilt is what produces the seasonal variations. The Earth is also not a perfect sphere; it bulges in the middle near the Equator. This unequal distribution of mass causes the Earth to "wobble" around its rotational axis like a gyroscope. What this means is that the Earth's axis makes its own rotation, with the North and South Poles slowly describing a circle around the ecliptic pole (which is the pole exactly perpendicular to the plane of the ecliptic; the North and South poles, remember are tilted 23.5 degrees away from this plane). How slowly? Well, a complete cycle takes about 25,800 years. The precession can also be seen in terms of the "North Star". Currently the North Pole of the Earth is aligned with the fixed star Polaris. This was not the case 3,000 years ago; and by the year 14,000 A.D., the North Star will be Vega, not Polaris.

This rotation of the Earth's axis occurs at something like 1° every 71.5 years

(about 5 seconds of arc per year). The "wobble" and the precession of the equinoxes were known to the Ancient Egyptians, although the first official "discovery" of it was made by an Ancient Greek astronomer, Hipparchus, who was born sometime around 190 B.C. It was noted because the Sun was in a slightly earlier position at the time of the Spring Equinox each year (as measured against the fixed stars). Because the movement slips backwards through the zodiac, it is called precession (as opposed to a forward-movement which would be called progression).

Now 1° every 71.5 years doesn't sound like too much, but it certainly adds up over 2,000 years or so, and this is where we get into the different Zodiac systems.

THE TROPICAL ZODIAC AND THE SIDEREAL ZODIAC



The ecliptic is a circle, and the thing about a circle is that it doesn't have a beginning or an end. If you want to be able to measure something along a circle, you have to establish some sort of a reference point. The Zodiac as we know it today was first used by the Ancient Greeks over 2,000 years ago. Their year began with the Spring Equinox, and so it made sense to pick that point - that is, the point in the sky where the Sun appeared to be at the time of the Spring Equinox, as the reference point, and then divide the ecliptic into 12 equal segments from there. At the time, the Spring Equinox occurred when the Sun was in the band of the ecliptic that also included part of the Constellation of Aries. The first 30 degree division of the ecliptic was named "Aries", and the remaining 11 segments were likewise named after the well-known and easily-recognized constellations that roughly corresponded in sequence. The Greeks never used the actual constellations to measure the positions of the planets, however, because the constellations did not divide the ecliptic into equal segments.

The type of astrology practiced at the time was entirely based on cycles. Each of the Signs of the Zodiac were associated with the type of qualities and energy that were experienced during the corresponding time of the year. The foundation of the interpretations of the Signs was seasonal. The Greeks were well aware of the precession of the equinoxes; however, as their system of astrology was based on the seasonal cycles, it did not concern them. Because this Zodiac begins with the Vernal Point, and the Spring Equinox, when the Sun is directly overhead at the Tropic of Cancer, this Zodiac is called the Tropical Zodiac, or the Seasonal Zodiac.

Although the Tropical Zodiac is used by the vast majority of Western

Astrologers, it is not the only Zodiac system. The Sidereal Zodiac (Sidereal = Star) does take the precession of the equinoxes into account, and rather than beginning its cycle at the point of the Spring Equinox each year, it begins when the Sun aligns with a Fixed Star in the Constellation of Aries. The Sidereal Zodiac is also known as the Fixed Zodiac.

While astrology was developing in the West, it was also developing in the East. Hindu astrology, called Vedic astrology or Jyotish astrology has always used the Sidereal Zodiac. Jyotish astrology has an entirely different set of techniques and interpretations for the signs and planets. The fundamentals may be the same as in Western Astrology, but the similarity ends there.

In the 1930's, Cyril Fagan began to advocate using the Sidereal Zodiac in Western Astrology, rather than using the Tropical Zodiac. Although definitely in the minority, there are many astrologers who practice Western Sidereal Astrology, using basically the same interpretations for the signs and the planets, but an entirely different measurement system. Currently, the difference between the Tropical Zodiac and the Sidereal Zodiac is about 23°. What this means is that the Spring Equinox, which occurs at 0° of Aries (Tropical) actually occurs at about 7° of the Sidereal Sign of Pisces. Because no one can agree as to the exact location of the start of the Constellation of Aries, and therefore to the point where the Sidereal Zodiac would begin, the Sidereal Zodiac is calculated backwards from the Vernal Point, using one of many different ayanamsas.

Tropical Astrology and Western Sidereal Astrology have fundamentally different approaches to the symbolism and interpretation of the Signs. Tropical Astrology believes that the qualities associated with the signs are linked to the seasons, rather than to the fixed stars, and therefore the precession of the equinoxes and the growing difference between the Tropical Signs and the relative positions of their namesake constellations is of no consequence. Sidereal Astrologers (both Western and Eastern) believe that the qualities of the signs are not related to the seasons, but rather to the specific portions of the ecliptic as measured against the fixed stars.

With respect to the question of the accuracy of ancient charts and interpretations, we only need to remember what Zodiac system was used at the time, and keep things in context. The Western Astrological tradition, which includes the Greeks, the Europeans, the English (in the Middle Ages), and the Americans in more recent years is based on the Tropical Zodiac. Therefore, all charts and interpretations from these times and places would be as accurate and valid today as they were then. Furthermore, the date, time and location information can be used to calculate a "modern" version of the ancient charts

with no adjustments (except for the necessary conversions to translate the more ancient dates into the modern calendar).

Any charts from the Eastern tradition, however, as well as any Western Sidereal charts (post 1930's) would require adjustments based on the precession of the equinoxes. The difference between the Tropical zodiac and the Sidereal Zodiac changes each year, and the degree of precession would have to be taken into account for the date of the chart. This would be rather nightmarish to try and calculate by hand; fortunately, most computer astrology programs that offer a Sidereal Zodiac option take this into account and can produce accurate Sidereal charts for any time or place.

A DIGRESSION INTO THE AGE OF AQUARIUS



The precession of the equinoxes has to do with more than just the two different zodiac systems. As the equinoxes precess, they relate to the Great Ages of Man. These Ages mark different periods where significant evolutionary changes occurred. The Ages are defined by the Sidereal Sign that is the current location of the Vernal Point. Currently, the Spring Equinox (0° of Aries in the Tropical Zodiac) occurs at about 7° of the Sidereal Sign of Pisces, and we are currently very much in the Age of Pisces, where we will stay for another 150-300 years or so until the Spring Equinox precesses into the Sidereal Sign of Aquarius, which will mark the beginning of the Age of Aquarius. (Even agreeing on this definition of the "Ages" there is much dispute as to the actual year that the "Age of Aquarius" will begin. The reasons and reasoning for this aren't terribly important to this discussion. Suffice it to say that it's not terribly likely that any of us will still be here to witness it.)

Each Great Age is associated with a major evolutionary and cultural advancement of the species. In the Age of Gemini, language was developed. In the Age of Taurus, agriculture was discovered, and for the first time, towns, villages, and cities were formed because humans no longer needed to hunt and gather for their food and so were not required to be so nomadic. The Age of Aries ushered in wars and warfare, violence and conquest. The Age of Pisces has been dominated largely by religion, Christianity in particular, with its peculiar mixture of persecution and spiritual salvation. The general thoughts about the Age of Aquarius are that it will mark a period of enlightenment and freedom. But once again, even the most generous estimates put this off for another 100 years at least.

MYTHS, MISCONCEPTIONS AND MISINFORMATION

The fact that the Signs of the Zodiac share the same names as 12 of the constellations, and were, in fact, named after the constellations, has resulted in the popular misconception that the signs are the same thing as the constellations. This fallacy has given rise to all sorts of pseudo-scientific attacks on the validity of astrology, all of which come from individuals who do not understand astrology in the first place. Some have even come from a small faction of Western Sidereal astrologers who attempt to discredit Tropical astrology. I'll list some of the most popular examples below, and then, since they all can be explained or refuted by the same information, tackle them all at once.

- **"The 13th Sign of the Zodiac."** This one pops up in the media from time to time. Sometimes it takes the angle that a new sign of the zodiac has been "discovered." Other times, it's used as an argument by sceptics attempting to discredit astrology. What it refers to is the Constellation of Ophiuchus, which also intersects the ecliptic, and which actually occupies more space along the ecliptic than the Constellation of Scorpio.
- **"The Sidereal Zodiac is the only 'real' zodiac because it uses the constellations and not imaginary divisions of the ecliptic."**
- **"How can you say that 'Jupiter is in Libra' when I can look up in the sky and see it clearly in Virgo?"**
- **"The Zodiac has all of the dates wrong because of the Precession of the Equinoxes."** Part of this is addressed above when the difference between the Tropical and the Sidereal Zodiacs is covered. The rest will be addressed below.

The data in the following table was published by Dr. Lee T. Shapiro, Director Morehead Planetarium, CB #3480 Morehead Building, University of North Carolina, Chapel Hill, NC 27599-3480. The dates and days refer to the time that the Sun appears to spend in each of the constellations. I took the days (based on a 365 day year) and converted them to the corresponding arcs that each constellation occupies along the ecliptic. I also included the approximate dates that the Sun enters each of the Signs, both in the Tropical Zodiac and also in the Sidereal Zodiac.

Constellation	Sun Enters/Leaves	# of Days	# of Degrees	Tropical Dates	Sidereal Dates
Aries	Apr 19 - May 13	25	24.66	Mar 21 - Apr 20	Apr 14 - May 14
Taurus	May 14 - Jun 19	37	36.49	Apr 21 - May 21	May 15 - Jun 14
Gemini	Jun 20 - Jul 20	31	20.58	May 22 - Jun 21	Jun 15 - Jul 15
Cancer	Jul 21 - Aug 9	20	19.73	Jun 22 - Jul 22	Jul 16 - Aug 16
Leo	Aug 10 - Sep 15	37	36.49	Jul 23 - Aug 22	Aug 17 - Sep 16
Virgo	Sep 16 - Oct 30	45	44.38	Aug 23 - Sep 23	Sep 17 - Oct 16
Libra	Oct 31 - Nov 22	23	22.69	Sep 24 - Oct 23	Oct 17 - Nov 15
Scorpio	Nov 23 - Nov 29	7	6.9	Oct 24 - Nov 22	Nov 16 - Dec 15
Ophichchus	Nov 30 - Dec 17	18	17.75	N/A	N/A
Sagittarius	Dec 18 - Jan 18	32	31.56	Nov 23 - Dec 21	Dec 16 - Jan 13
Capricorn	Jan 19 - Feb 15	28	27.62	Dec 22 - Jan 20	Jan 14 - Feb 12
Aquarius	Feb 16 - Mar 11	24	23.67	Jan 21 - Feb 19	Feb 13 - Mar 12
Pisces	Mar 12 - Apr 18	38	37.48	Feb 20 - Mar 20	Mar 13 - Apr 13

The table should illustrate clearly the difference between the **signs** and the **constellations**. The **signs**, you will remember, are units of measurement, each consisting of 30 degrees of arc. The **constellations** may take up an average of about 30 degrees of arc each, but they certainly aren't very useful as units of measurement.

This is also the answer to the "13th Sign" myth. While there are most certainly 13 **constellations** that cross the ecliptic, the **signs** are not the same thing as the **constellations**. Why the Ancients chose to name the 8th Sign after Scorpio (which barely takes up 7° of arc) rather than Ophicuchus (which covers a more respectable 17.75°) will probably remain a mystery.

It should also be obvious from looking at this table that the Sidereal Zodiac does not rely on the constellations any more than the Tropical Zodiac does. While there is certainly a greater correlation between the Sidereal Signs and the constellations along the ecliptic, again, the constellations do not divide the ecliptic into equal segments and therefore they are not used as the basis for the Sidereal Zodiac. In fact, there even appears to be a discrepancy between when Dr. Shapiro notes that the Sun Enters the Constellation of Aries and when the Sidereal Sign of Aries is thought to begin (for the year 1997).

The discrepancy between where astrologers place a planet in the night sky, and where astronomers place that same planet is also related to the difference between the Constellations, the Tropical Zodiac and the Sidereal Zodiac. Based on the dates in the table, on October 24, the Sun would be found in the Constellation of Virgo, the Tropical Sign of Scorpio, and the Sidereal Sign of Libra.

And finally, the argument that astrology can't work because the precession of the equinoxes make it invalid, or at least wildly inaccurate (which is essentially what the "scientist" was referring to who prompted Debbie's question), simply brings up the difference between the Tropical and the Sidereal Zodiacs. along the ecliptic, again, the constellations do not divide the ecliptic into equal segments and therefore they are not used as the basis for the Sidereal Zodiac. In fact, there even appears to be a discrepancy between when Dr. Shapiro notes that the Sun Enters the Constellation of Aries and when the Sidereal Sign of Aries is thought to begin (for the year 1997).

Once again, although the Tropical and the Sidereal Zodiacs are very different, they each represent an entirely valid system of astrology.



Navigation in the Information Age:
An Exploration of the Potential Use
of Geographic Information Systems (GIS)
for Sustainability and Self-Determination in Hawai`i
Cogswell and Schiøtz, 1996

<-- [FRONT PAGE](#)

[CONTENTS](#)

[LIST OF FIGURES](#) --

>

Abstract

The use of Geographic Information Systems (GIS) by indigenous peoples for self-determination, sustainable resource management, and assertion of land claims is increasing worldwide. GIS can be described as a powerful computerized version of the Western written map, with the ability to store, analyze, and display large amounts of diverse spatial data. This research undertook to explore the GIS initiative of the sovereignty group "Nation of Hawai`i," and to study recent literature and the larger context of GIS use in Hawai`i, for the purpose of better understanding if and how GIS can assist the Nation of Hawai`i in its struggle for self-determination and eventually, for sustainable management of the Hawaiian archipelago. For this research, a collaborative approach to participant observation was chosen to create a stronger sense of anthropological reflection, and to enable a more ambitious project to be undertaken.

[TABLE OF CONTENTS](#)

Navigation in the Information Age:
An Exploration of the Potential Use
of Geographic Information Systems (GIS)
for Sustainability and Self-Determination in Hawai`i
Cogswell and Schiøtz, 1996

Table of Contents

[Abstract](#)

[List of Figures](#)

[Note: figures are not yet included in online version.]

[Acknowledgements](#)

[Illustration and Quote - Navigation and Information](#)

1 [Introduction](#)

- 1.1 [Hawaiian Context](#)
- 1.2 [What is known about GIS?](#)
- 1.3 [The Power of Maps and GIS](#)
- 1.4 [Overall Context](#)
- 1.5 [Intentions of Research](#)

2 [Theoretical Orientation and Literature Review](#)

- 2.1 [The Power of Maps](#)
 - 2.1.1 [Maps and Culture](#)
 - 2.1.2 [Maps, Empire, Exploitation, and Power](#)
 - 2.1.3 [Maps, Vision, Protest, and Empowerment](#)
- 2.2 [Social Implications of GIS](#)
 - 2.2.1 [Overview of the Literature](#)
 - 2.2.2 [GIS - Objectivity, Neutrality, and Other Assumptions](#)
 - 2.2.3 [GIS and Other Ways of Knowing - Knowledge Representation and Privilege](#)
- 2.3 [Applied and Advocacy Anthropology](#)

[2.4 Anthropology and Technology](#)

[2.4.1 Cyborg Anthropology](#)

[2.4.2 Users and Designers](#)

[2.4.3 Information Technology: Impacts and Potentials for Communities](#)

[3 Methodology](#)

[3.1 Personal Context](#)

[3.1.1 Personal Background](#)

[3.1.2 Why a Collaborative Approach?](#)

[3.1.3 Thesis Project - the Beginning](#)

[3.1.4 Biases](#)

[3.2 Qualitative Research and Ethnographic Method](#)

[3.3 Our Research Odyssey](#)

[3.3.1 First stage - Refining our Focus, Establishing Rapport with Alan Crutchfield](#)

[3.3.2 Second Stage - Immersion in Los Angeles](#)

[3.3.3 Third Phase - Hawai`i](#)

[4 History /Context](#)

[4.1 Western Maps and Hawai`i](#)

[4.1.1 The Invention of "Space" and the Western Map](#)

[4.1.2 Polynesian "Mapping"](#)

[4.1.3 The First Maps of Hawai`i](#)

[4.2 Hawai`i - Consequences of Being "On the Map"](#)

[4.2.1 Sovereignty Lost](#)

[4.2.2 Sovereignty Regained?](#)

[4.3 Context and History of GIS](#)

[4.3.1 GIS Development](#)

[4.3.2 Indigenous Peoples' Use of GIS](#)

[5 The Nation of Hawai`i](#)

[5.1 Nation of Hawai`i's Story](#)

[5.1.1 Introduction: Land and Sovereignty](#)

[5.1.2 Makapu`u](#)

[5.1.3 Pu`uhonua o Waimanalo](#)

[5.1.4 The Leader - Pu`uhonua Kanahale](#)

5.1.5 [The Trial](#)

5.2 [Nation of Hawai`i and Technology](#)

5.2.1 [Nation of Hawai`i Web Page - Guest Comments](#)

5.3 [Nation of Hawai`i and Sustainability](#)

5.4 [Nation of Hawai`i's GIS initiative](#)

6 Government GIS use in Hawai`i

6.1 [City and State GIS Initiatives](#)

6.1.1 [GIS Systems](#)

6.1.2 [Institutional Dynamics](#)

6.1.3 [Information Access](#)

6.2 [Reflections and Criticism](#)

7 GIS and Public Access in Hawai`i

7.1 [Information and Technology Access](#)

7.1.1 [Public Water Quality GIS Initiative](#)

7.1.2 ['Insider Information'](#)

7.1.3 [The Nature Conservancy: Conservation and Covert Information](#)

7.2 [Knowledge Production](#)

8 Conclusion

8.1 [Focused Recommendations to the Nation of Hawai`i](#)

8.1.1 [Suggestions for immediate actions:](#)

8.1.2 [Recommendations for actions while the State still claims power:](#)

8.1.3 [How can GIS be used for self-determination and sustainability by a sovereign Hawaiian Nation?](#)

8.1.4 [Questions to ask in working with GIS](#)

8.2 [Directions for Further Research](#)

8.3 [Relevance of Academic Critique](#)

8.4 [Limitations of the Research](#)

8.5 [Impact on the Researchers](#)

8.5.1 [Shared Personal Reflections](#)

8.5.2 [Reflections on Collaboration](#)

8.5.3 [Ulrik Schiøtz's Personal Reflections](#)

8.5.4 [Christopher Cogswell's Personal Reflections](#)

8.6 [Final Comments](#)

9 Appendix - Additional Figures

[Note: these figures have not yet been added to the online version]

- 9.1 Example of 15 GIS maps from the Waiahole - Kulaloa Project
- 9.2 Building a GIS Database chart
- 9.3 Components of GIS chart
- 9.4 "Enterprise-wide GIS" chart
- 9.5 GIS Commercial - "Reality, What a Concept"
- 9.6 World Map of the Ocean Floor
- 9.7 Cartoon

10 References